

EMBREY BUILDERS, LLC.
1020 N. E. Loop 410, Suite 700
San Antonio, TX 78209
Ph: (210) 824-6044 Fax: (210) 824-7656

RFI

To: Erik Earnshaw
Beeler Guest Owens Architects
4245 N. Central Expressway
Suite 300
Dallas, TX 75205
Ph: 214/520-8878 Fax: 214/520-8879

RFI #: 123
Date: 5/21/2012
Job: EB-02 Keller Springs Lofts
Phone: 877-777-5115

CC:

Subject: A2 & A2-SP Cased Openings

Drawing: A2.3 & A2.3A
Cost Impact: None

Spec Section:
Schedule Impact: None

Request: Date Required: 5/29/2012
A2 Unit - A cased opening is called for between the LR and the hallway. Is this a wood cased opening? Please provide an elevation sketch to show height.
A2-SP Unit - Dashed lines are shown between entry and kitchen and between the kitchen and hallway. Are these cased openings? If so, please provide an elevation sketch showing opening heights.

Requested by: David Miller
Embrey Builders LLC

Response: In both units, the cased opening is a flat opening at 6'-8" just like a door opening. Adding the wood casing is your option. BGO is fine with or without a door frame trim going around the opening.

Ryan Faulds
BGO architects
June 01, 2012

Answered by _____

Company _____

Date _____

Page 1 of 1

Platform for LowBoy & Tailboy

EMBREY STANDARD DETAIL
5/29/12

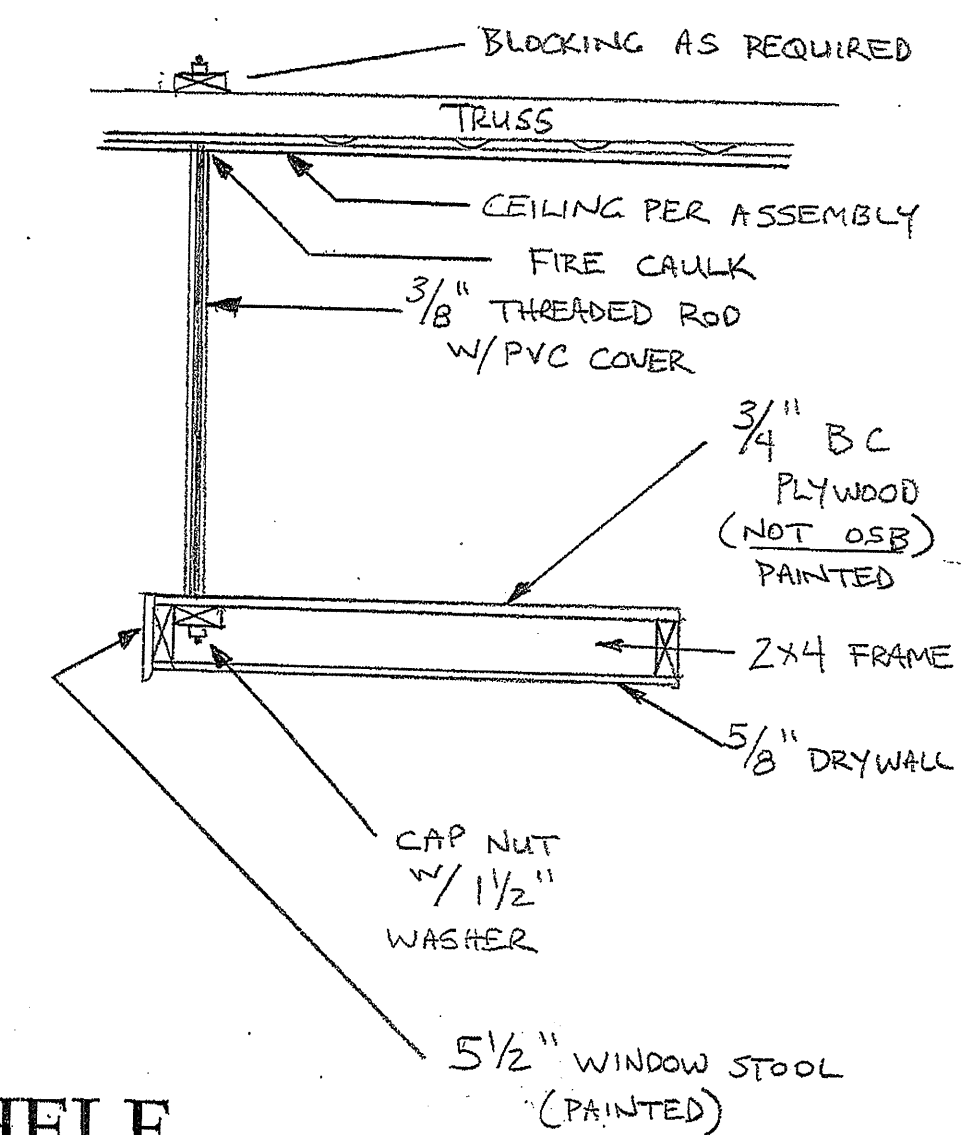
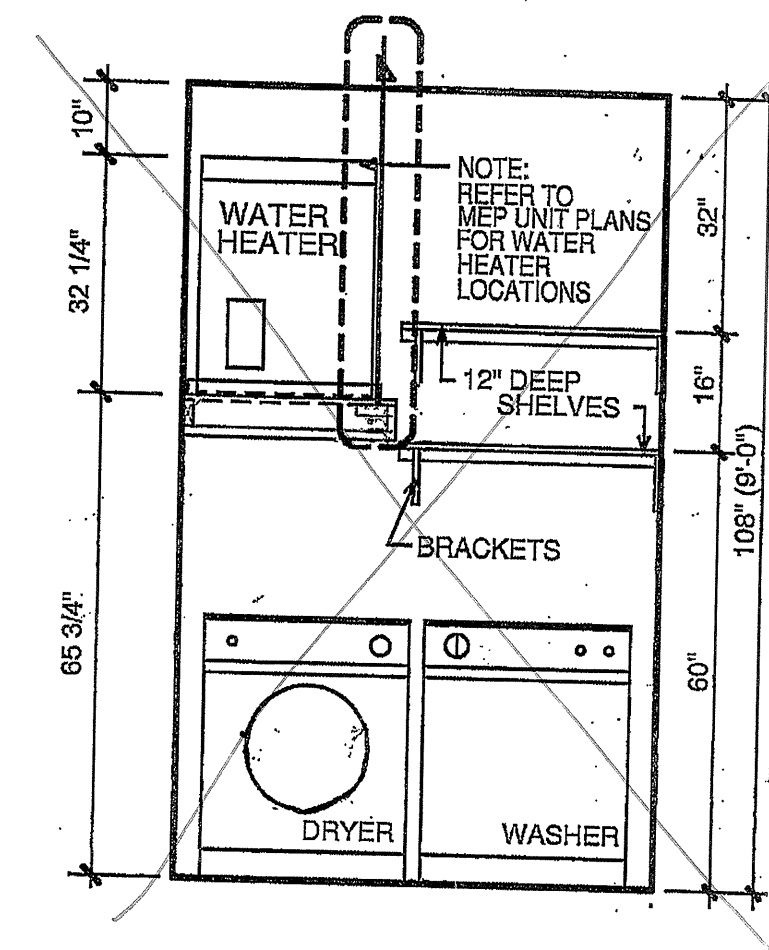

**SUSPENDED
WATER HEATER SHELF**