

PLAN VIEW
SCALE 1/2" = 1'-0"
STA. 1+94.73 LN 'D'
STA. 0+47 LN 'F'

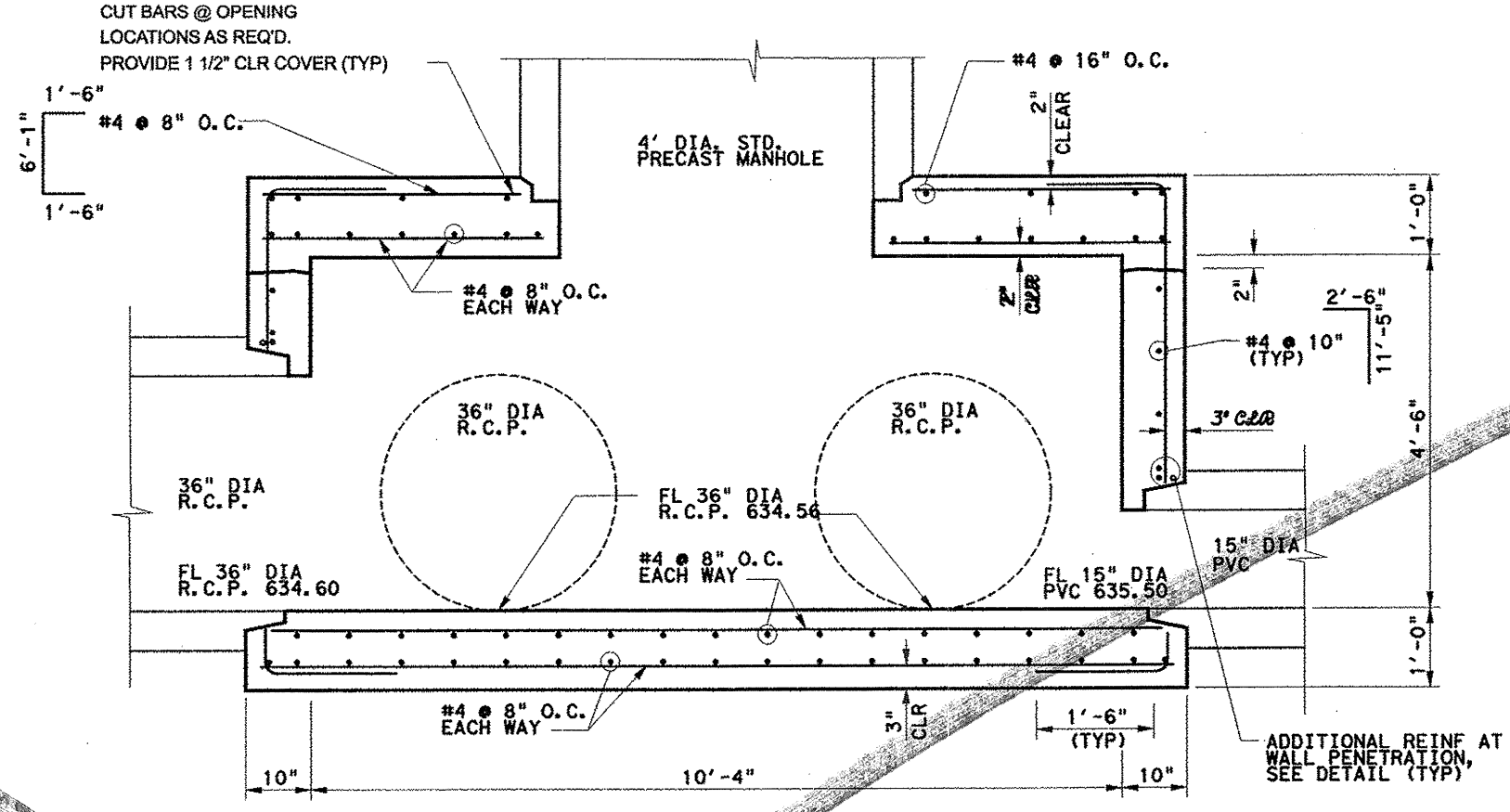

SECTION B-B
SCALE 1/2" = 1'-0"
STA. 1+94.73 LN 'D'
STA. 0+47 LN 'F'

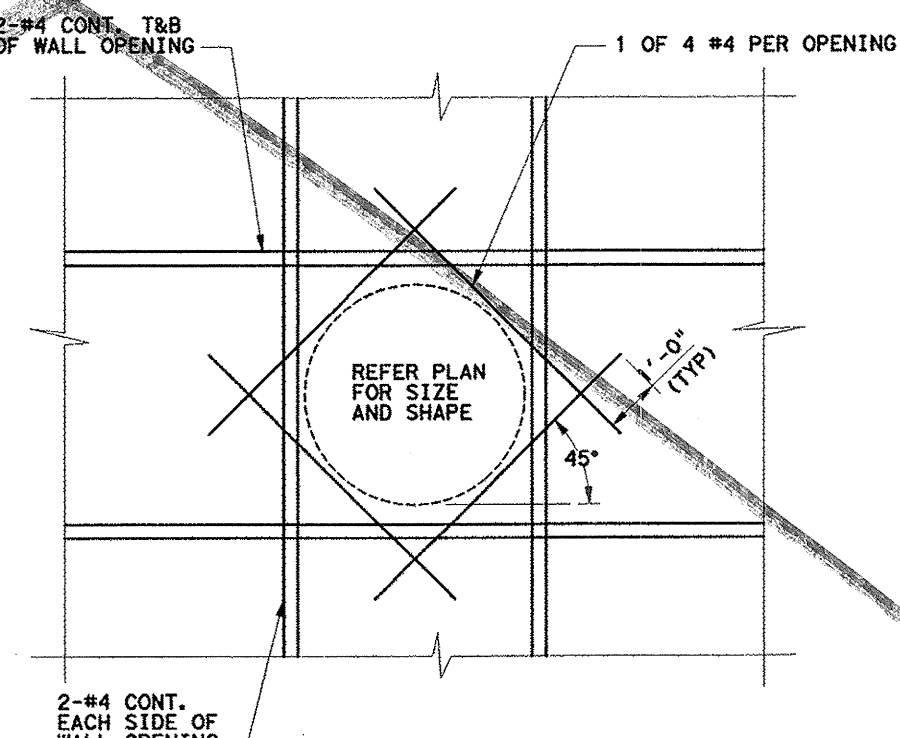

DETAILS OF ADDITIONAL REINFORCEMENT AT TYPICAL WALL PENETRATION
SCALE 1/2" = 1'-0"

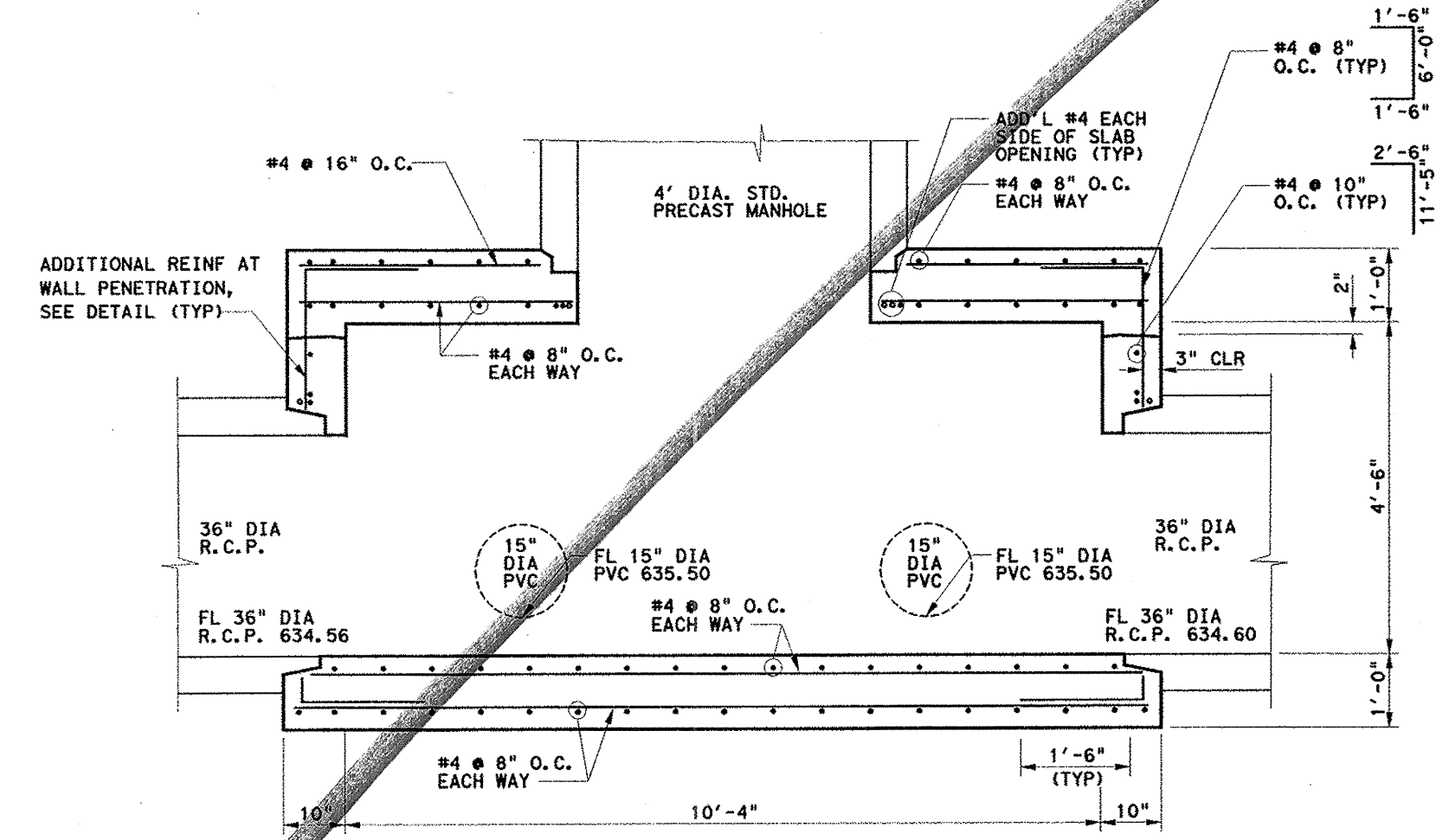

SECTION A-A
SCALE 1/2" = 1'-0"
STA. 1+94.73 LN 'D'
STA. 0+47 LN 'F'

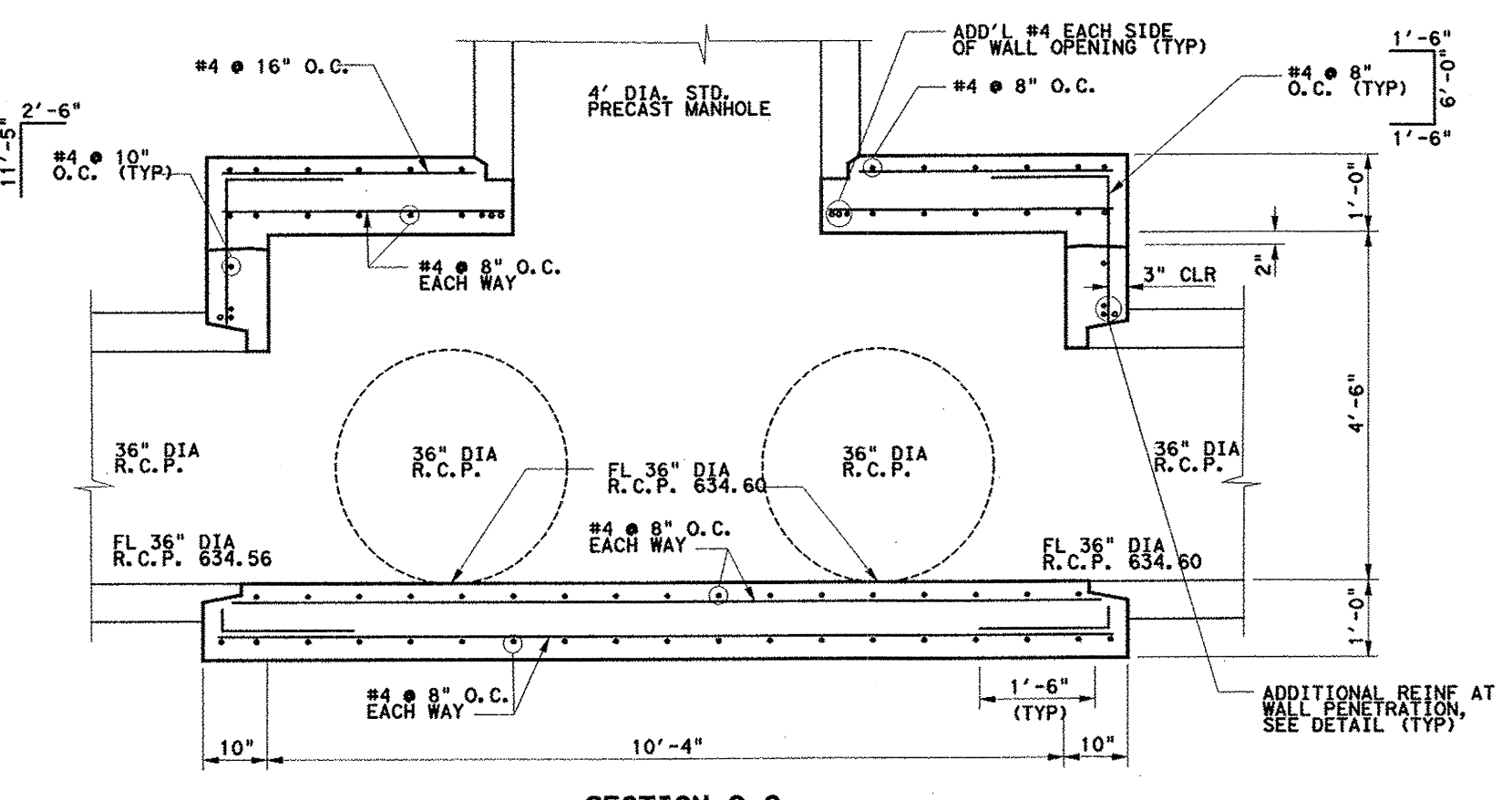

SECTION C-C
SCALE 1/2" = 1'-0"
STA. 1+94.73 LN 'D'
STA. 0+47 LN 'F'

GENERAL NOTES:

- ALL WORK SHALL CONFORM TO REQUIREMENTS OF STANDARD SPECIFICATIONS FOR HIGHWAY BRIDGES, 2002 17TH EDITION, HEREIN REFERRED TO AS THE STANDARD SPECIFICATION, AND/OR ADDITIONAL PREVAILING CODES.
- NOTES HEREIN EXCEPTED FROM THE STANDARD SPECIFICATIONS ARE FOR GENERAL INFORMATION ONLY AND DO NOT RELIEVE THE CONTRACTOR'S RESPONSIBILITIES FOR OBTAINING COPIES OF AND/OR CONFORMING TO THE STANDARD SPECIFICATIONS.
- WRITTEN DIMENSIONS ON THESE DRAWINGS SHALL HAVE PRECEDENCE OVER SCALED DIMENSIONS. CONTRACTOR SHALL COORDINATE, VERIFY AND BE RESPONSIBLE FOR ALL DIMENSIONS, DETAILS AND CONDITIONS BEFORE STARTING THE WORK.
- CONTRACTOR SHALL BE FULLY RESPONSIBLE FOR SHORING AND BRACING OF ALL WORK INCLUDING PROTECTION OF EXISTING STRUCTURES AND UTILITIES.
- ANY SUBSTITUTIONS SHALL BE SUBMITTED TO THE ENGINEER PRIOR TO INSTALLATION, SHALL HAVE PREVIOUS APPROVAL FROM THE GOVERNING BUILDING DEPARTMENT AND SHALL HAVE EITHER A CURRENT INTERNATIONAL CONFERENCE OF BUILDING OFFICIALS RESEARCH REPORT OR A NATIONAL EVALUATION REPORT.
- BACKFILL SHALL BE A COMPACTED EXISTING SITE SOIL OR ROCK AS APPROVED BY THE GEOTECHNICAL ENGINEER WITH MAXIMUM EQUIVALENT FLUID PRESSURE OF 80 PSF/FT DEPTH. UPPER 18" OF BACKFILL SHALL BE SEALED WITH A COMPACTED COHESIVE SOIL ($P_i > 25$).
- BACKFILL SHALL BE PLACED AS STANDARD COMPACTED EARTH/FILL, PLACED IN 8 INCH THICK LOOSE LIFTS AND COMPACTED AT 92% (MINIMUM) OF THE MAXIMUM DRY DENSITY AT OPTIMUM MOISTURE CONTENT. CARE SHOULD BE TAKEN TO ASSURE ADEQUATE COMPACTION ADJACENT TO WALL WITH MANUAL COMPACTION EQUIPMENT (NO HEAVY EQUIPMENT). NO VEGETATION OR ROCKS GREATER THAN 3 INCHES IN ANY DIMENSION SHALL BE ALLOWED IN THE FILL.
- SUB-GRADE PREPARATION AND BACKFILL MATERIALS AND COMPACTION TO BE UNDER THE SUPERVISION OF THE GEOTECHNICAL FIRM, REED ENGINEERING GROUP, LTD. A MINIMUM ALLOWABLE BEARING PRESSURE OF 2000 PSF SHALL BE OBTAINED.
- CONCRETE FOR WALLS AND SLABS:
f'c = 4000 PSI @ 28 DAYS, NORMAL WEIGHT
COARSE AGGREGATE SIZE NO. 57, 1" MAXIMUM
AIR-ENTRAIMENT 2-1/2% BY VOLUME
WATER-CEMENT RATIO 0.48
CEMENT CONTENT 470 LBS PER CUBIC YARD MINIMUM
SLUMP 4" ± 1" WITH WATER REDUCING ADMIXTURE
FLY ASH - 20-25% MAY BE ADDED
- REINFORCING BARS SHALL CONFORM TO ASTM A615, GRADE 60.
- ALL REINFORCING BARS SPLICE SHALL BE 40 BAR DIA. (18" MINIMUM) UNLESS OTHERWISE SHOWN ON THE DRAWINGS.
- UNLESS OTHERWISE NOTED (UNO), ALL DETAILING, FABRICATION AND PLACING OF REINFORCING STEEL SHALL CONFORM TO THE "MANUAL OF STANDARD PRACTICE FOR DETAILING REINFORCED CONCRETE STRUCTURES" - A.C.I. 315.
- ALL REINFORCING BAR HOOKS SHOWN ON DRAWINGS SHALL BE A.C.I. STANDARD 90 DEGREE HOOKS, UNO.
- CHAMFER ALL EXPOSED EXTERNAL CORNERS OF CONCRETE WITH 1/4" X 45 DEGREE CHAMFER, UNO.
- EXPANSION JOINT MATERIAL SHALL CONFORM TO ASTM D-1751 FOR NON-EXTRUDING AND RESILIENT BITUMINOUS TYPES.
- REFER TO GEOTECHNICAL ENGINEER FOR RECOMMENDED TECHNICAL PROVISIONS FOR THE CONSTRUCTION PRACTICE IN SHORING AND SLOPING OF EXCAVATIONS AND REQUIRED COMPACTION REQUIREMENTS. GEOTECHNICAL ENGINEER SHALL OBSERVE FOOTING/SLAB SUBGRADE BEFORE CONCRETE PLACEMENT.
- TIME OF OPEN EXCAVATION FOR WALL CONSTRUCTION SHALL BE LIMITED PER GEOTECHNICAL ENGINEER.
- CLEAR SPACING BETWEEN REINFORCING BARS SHALL BE A MINIMUM OF 1/2 BAR DIAMETERS, OR 1/2", OR 1 TIMES THE MAXIMUM AGGREGATE SIZE, WHICHEVER IS GREATER.
- REINFORCING SHALL HAVE THE FOLLOWING MINIMUM PROTECTIVE COVER OF CONCRETE, UNO:
A) 3" - CONCRETE CAST AGAINST GROUND
B) 2" - FORMED CONCRETE SURFACES IN CONTACT WITH GROUND
C) 2" - FORMED CONCRETE SURFACES EXPOSED TO WEATHER
D) 2" - TOP REINFORCEMENT IN DECK SLABS
- NO OPENINGS FOR PIPES, CONDUIT, ETC. SHALL BE MADE IN CONCRETE WITHOUT THE APPROVAL OF THE STRUCTURAL ENGINEER UNLESS SHOWN ON THE DRAWINGS.

Kimley-Horn and Associates, Inc.
2700 Park Central Drive, Suite 600
Dallas, TX 75245-5518 972-770-5800
FAX: 972-770-5800
INC.

Revision	Date

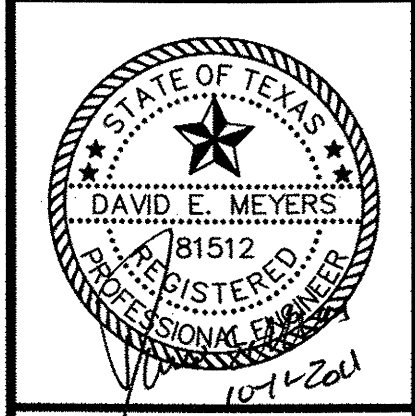

Keller Springs Lofts
Loft Apartments in Addison
Town of Addison, Texas

JUNCTION STRUCTURE DETAILS

DATE: OCTOBER 11, 2011
DESIGN: KHA
DRAWN: KHA
CHECKED: KHA
KHA NO: 064362003
CITY NO: