

SPECIAL INSPECTION

- 1. PARKIN-PERKINS-OLSEN CONSULTING ENGINEERING, INC. (PPO) IS NOT THE REGISTERED DESIGN PROFESSIONAL IN RESPONSIBLE CHARGE ACTING AS THE OWNER'S AGENT...

Table with 2 columns: INSPECTION TASKS PER 2006 IBC, INSPECTION FREQUENCY (CONTINUOUS, PERIODIC)

STEEL CONSTRUCTION (SECTION 1704.3 AND TABLE 1704.3)

Table with 3 columns: Task description, Continuous, Periodic

CONCRETE CONSTRUCTION (SECTION 1704.4 AND TABLE 1704.4)

Table with 3 columns: Task description, Continuous, Periodic

MASONRY CONSTRUCTION (SECTION 1704.5 AND TABLE 1704.5.1)

Table with 3 columns: Task description, Continuous, Periodic

WOOD CONSTRUCTION (SECTION 1704.6)

Table with 3 columns: Task description, Continuous, Periodic

SOILS (SECTION 1704.7)

Table with 3 columns: Task description, Continuous, Periodic

DOWEL SCHEDULE table with columns: MARK, SIZE, A, B, C

- NOTES: 1. SCHEDULED SPACING ARE MARKED "DWL." ON THE SECTIONS AND DETAILS...

2 SCHEDULE NO SCALE

REINFORCING LAP SPLICE SCHEDULE table with columns: BAR SIZE, LAP

3 SCHEDULE NO SCALE

COLUMN BASE PLATE SCHEDULE table with columns: COLUMN SIZE, LOCATION, BASE PLATE, ANCHOR BOLTS, EMBEDMENT, HOOK

- NOTES: 1. OVERSIZED HOLES IN PLATES ARE PERMITTED FOR TOLERANCE ON LOCATION OF ANCHOR BOLTS...

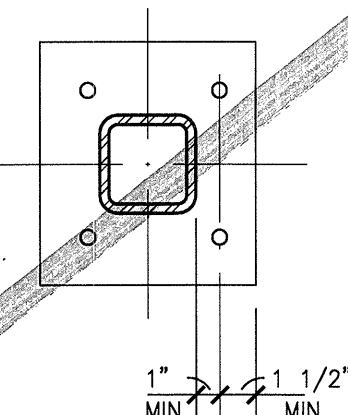

5 SCHEDULE NO SCALE

FOOTING SCHEDULE table with columns: MARK, WIDTH, LENGTH, DEPTH, REINFORCEMENT

- NOTES: 1. FOOTING DEPTH SHALL MATCH GRADE BEAM DEPTH, U.N.O.

6 SCHEDULE NO SCALE

TYPICAL POST-TENSION TENDON ELONGATION SCHEDULE table with multiple columns for tendon mark and elongation

- NOTES: 1. ELONGATIONS NOTED ABOVE ARE FOR ESTIMATING PURPOSES ONLY...

7 SCHEDULE NO SCALE

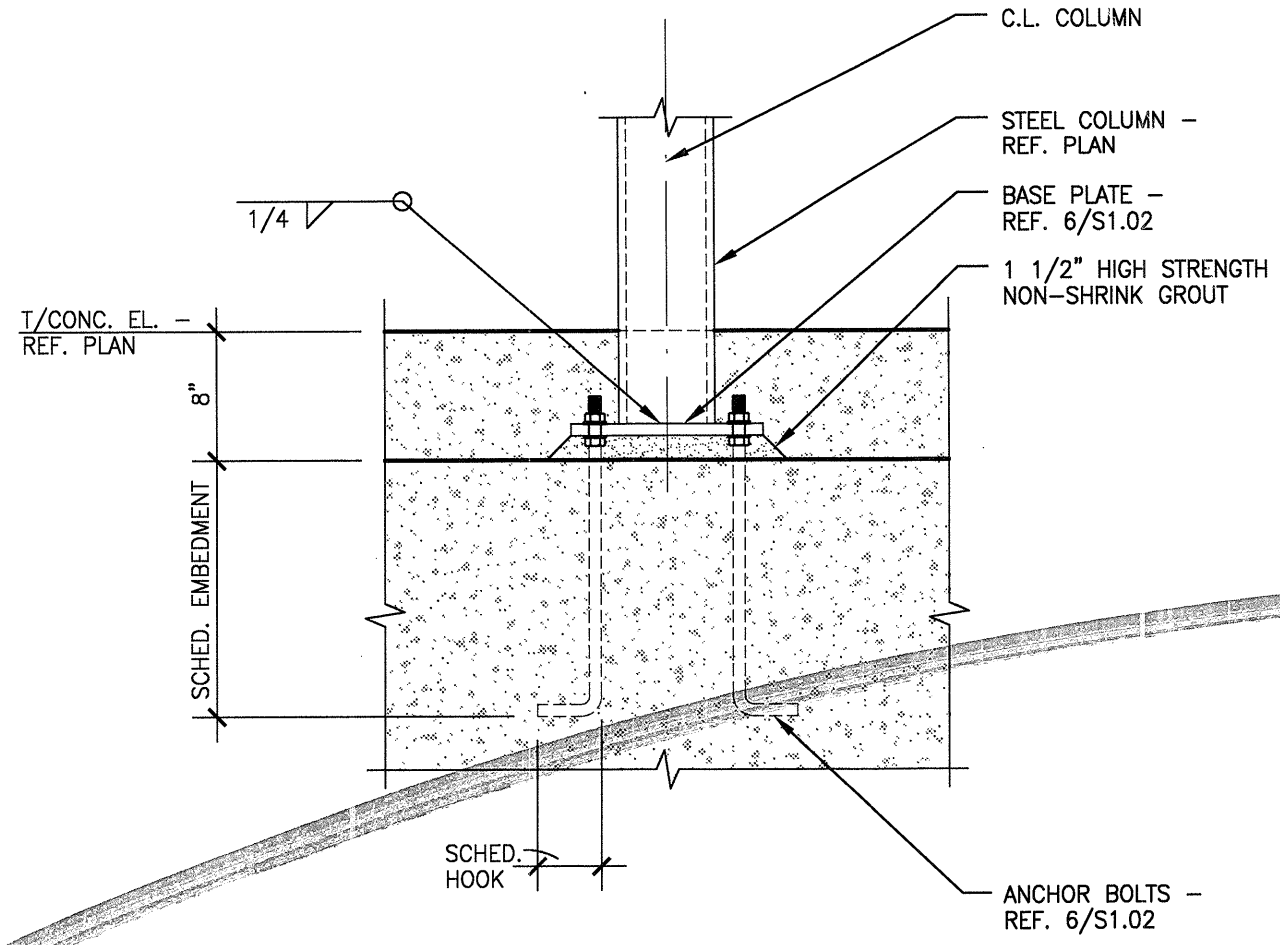

4 TYPICAL BASE PLATE DETAIL NO SCALE

REVISIONS table with columns for revision number and description

KELLER SPRINGS LOFTS LOFT APARTMENTS IN ADDISON, TEXAS

CONSTRUCTION ISSUE 10-17-2011

BGO architects logo and address: 4144 N. Central Exp., Suite 856, Dallas, TX 75204

DATE 08-05-2011

PROJECT 11129

SHEET NUMBER

S1.02

Professional Engineer seal for R. Trent Perkins, P.E. 84264, State of Texas

PPO logo and contact information: PARKIN - PERKINS - OLSEN CONSULTING ENGINEERING, INC. 9330 DBJ Freeway, Suite 1055, Dallas, Texas 75243