

KELLER SPRINGS ROAD

ADDISON ROAD TO DALLAS PARKWAY

PAVEMENT MARKING PLAN

FOR THE

TOWN OF ADDISON, TEXAS

PLANS FOR THIS PROJECT	
SHEET	DESCRIPTION
1	COVER SHEET
2	PLAN 0+00 TO 8+00
3	PLAN 8+00 TO 19+00
4	PLAN 19+00 TO 26+00

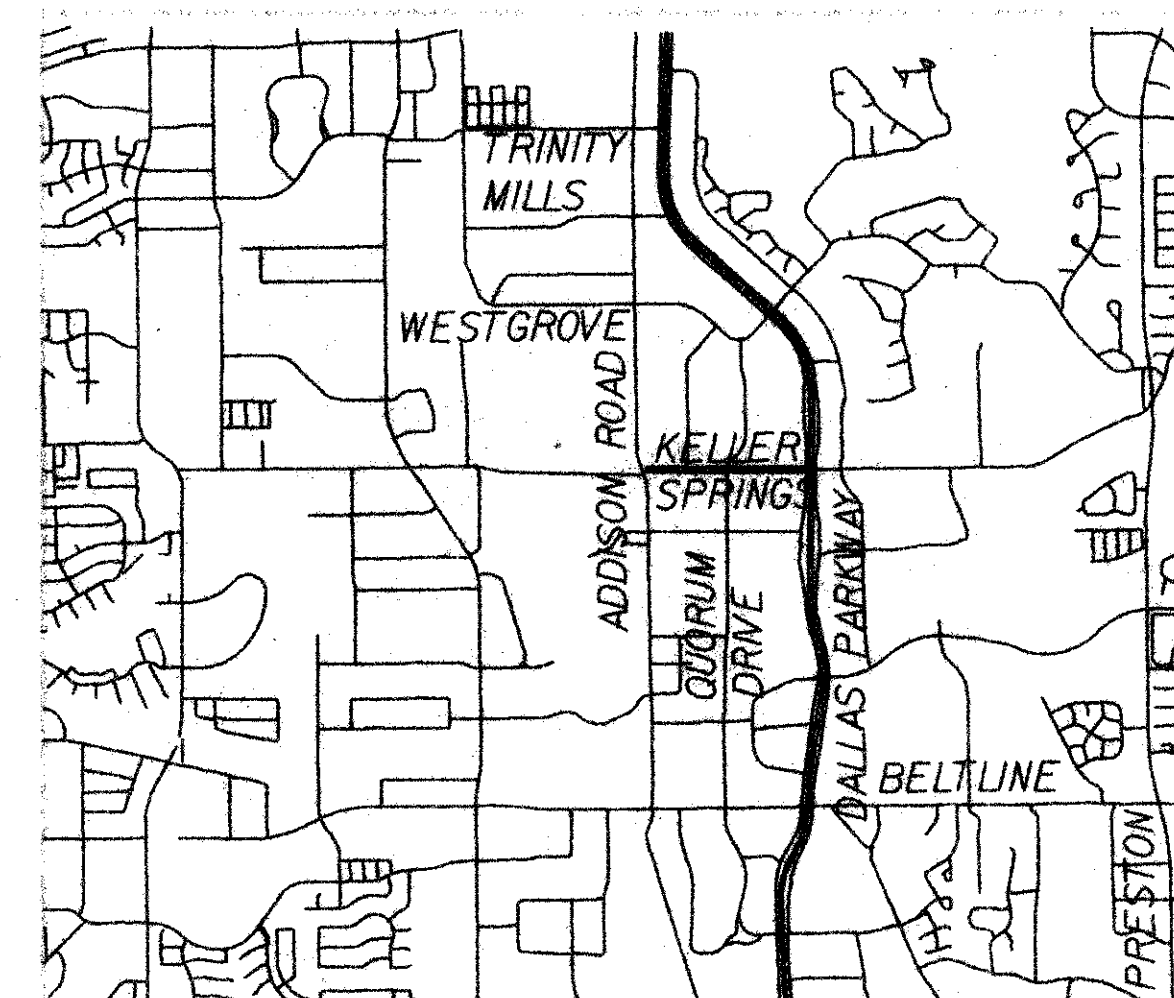

AREA MAP

OWNER : **PUBLIC WORKS**

TOWN OF ADDISON
16801 WESTGROVE
ADDISON, TEXAS 75248

ENGINEER :

DAL-TECH
ENGINEERING, INC.

17311 DALLAS PARKWAY, SUITE 200
DALLAS, TEXAS 75248
PH. (972) 250-2727

APRIL 2001
JOB 0106

KELLER SPRINGS ROAD

ADDISON ROAD TO DALLAS PARKWAY

PAVEMENT MARKING PLAN

FOR THE

TOWN OF ADDISON, TEXAS

PLANS FOR THIS PROJECT	
SHEET	DESCRIPTION
1	COVER SHEET
2	PLAN 0+00 TO 8+00
3	PLAN 8+00 TO 19+00
4	PLAN 19+00 TO 26+00

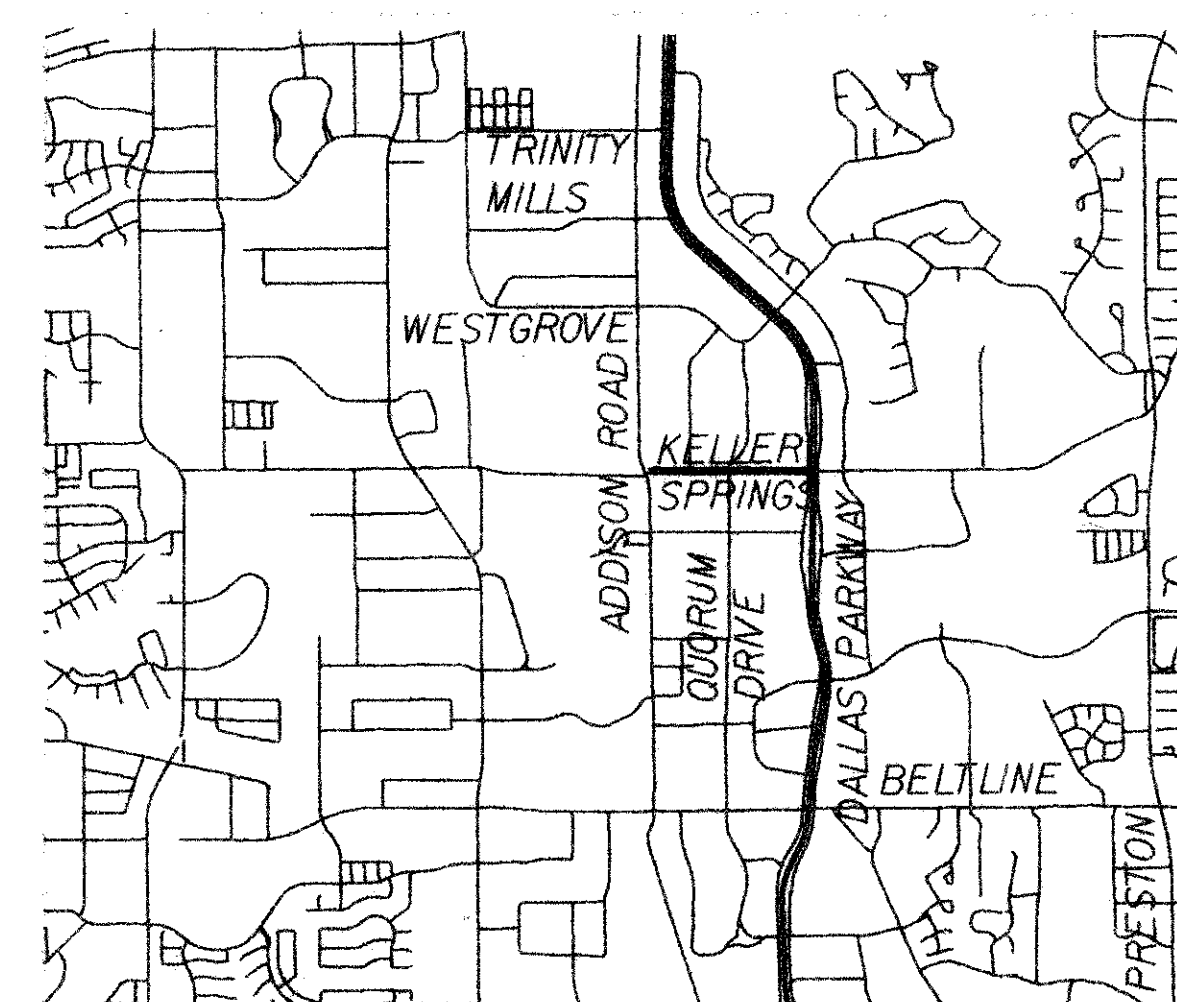

AREA MAP

OWNER : PUBLIC WORKS

TOWN OF ADDISON
16801 WESTGROVE
ADDISON, TEXAS 75248

ENGINEER :

DAL-TECH
ENGINEERING, INC.

17311 DALLAS PARKWAY, SUITE 200
DALLAS, TEXAS 75248
PH. (972) 250-2727

APRIL 2001
JOB 0106

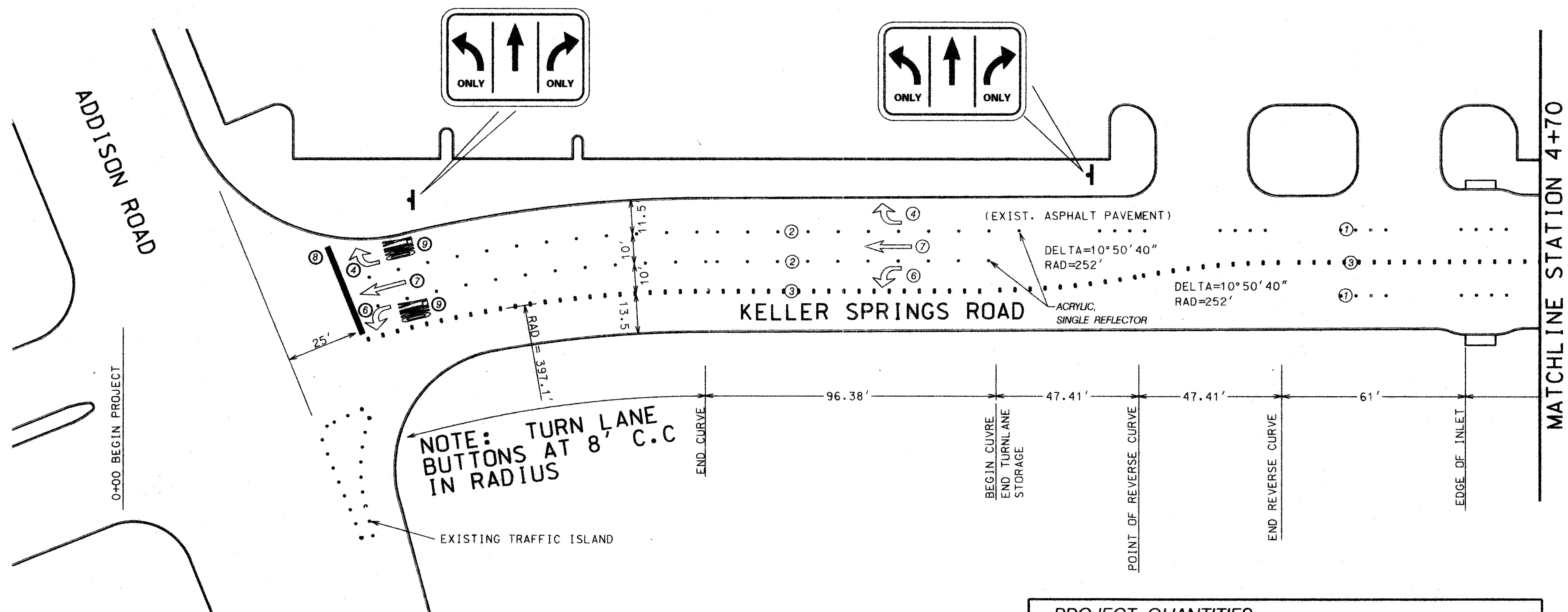

NOTE: TURN LANE BUTTONS AT 8' C.C IN RADIUS

PROJECT QUANTITIES				
ITEM	DESCRIPTION	SYMBOL	UNIT	QUANTITY
1	4" WHITE, RAISED CERAMIC PAVEMENT MARKERS, NON-REFLECTIVE	○	EACH	330
2	4" WHITE, RAISED ACRYLIC PAVEMENT MARKERS, SINGLE REFLECTOR	◻	EACH	227
3	4" YELLOW, RAISED CERAMIC PAVEMENT MARKERS, NON-REFLECTIVE	○	EACH	777
4	4" YELLOW, RAISED ACRYLIC PAVEMENT MARKERS, DOUBLE REFLECTORS	◻	EACH	258
5	RIGHT TURN ARROW SOLID WHITE ALKYD THERMOPLASTIC	↷	EACH	4
6	THRU / RIGHT TURN ARROW SOLID WHITE ALKYD THERMOPLASTIC	↷↶	EACH	2
7	LEFT TURN ARROW SOLID WHITE ALKYD THERMOPLASTIC	↶	EACH	7
8	THRU ONLY ARROW SOLID WHITE ALKYD THERMOPLASTIC	↶↷	EACH	2
9	STOP BAR 24" WIDE, WHITE ALKYD THERMOPLASTIC	—	L.F.	168
10	"ONLY" LANE MARKING SOLID WHITE ALKYD THERMOPLASTIC		EACH	7
11	6" WIDE CROSSWALK STRIPE SOLID WHITE ALKYD THERMOPLASTIC	===	L.F.	565
12	REMOVE AND DISPOSE OF EXISTING 18" WIDE ALKYD THERMOPLASTIC	▨	L.F.	38

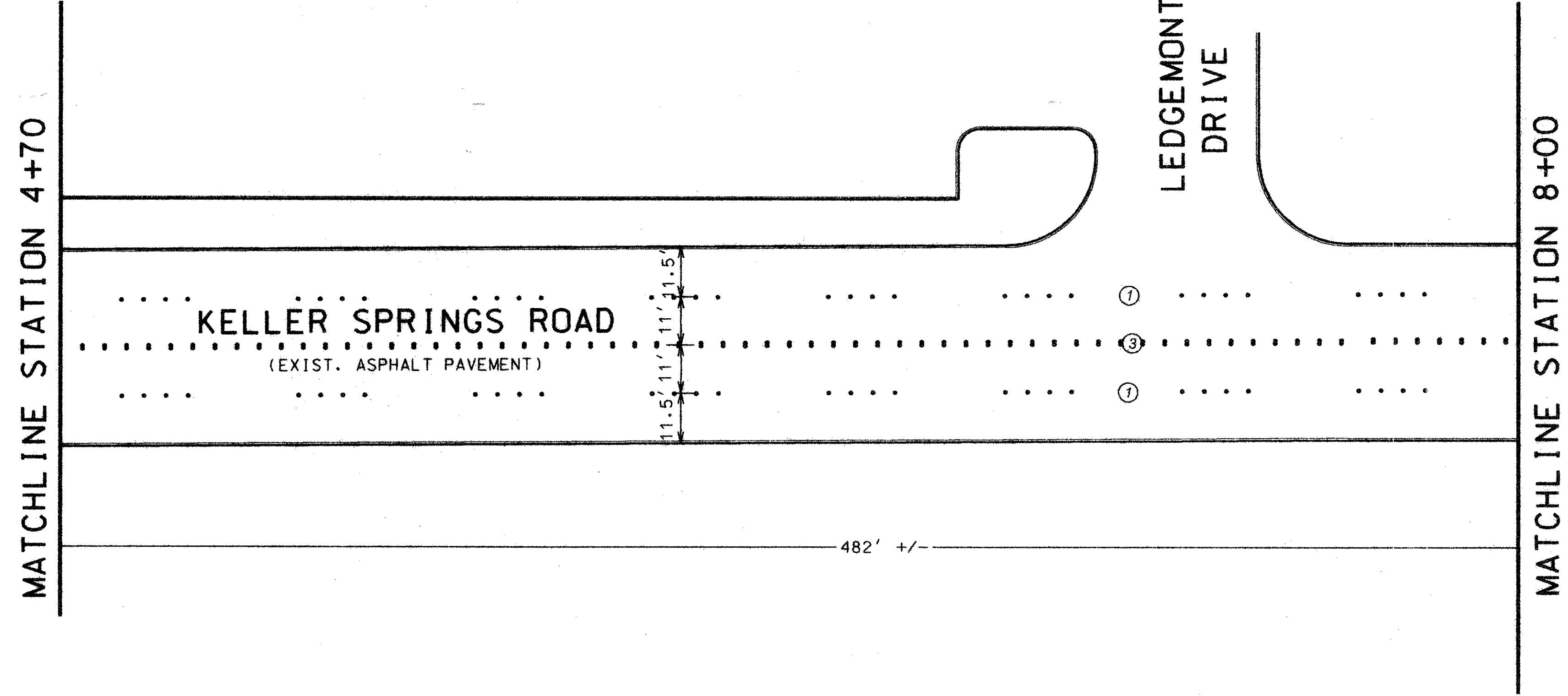

LEGEND		
①	LANE STRIPE - 4" WHITE RAISED PAVEMENT MARKERS, ACRYLIC SINGLE REFLECTIVE AND CERAMIC NON-REFLECTIVE
②	TURN LANE BAY DIVIDE - 4" WHITE, RAISED PAVEMENT MARKERS, ACRYLIC SINGLE REFLECTIVE AND CERAMIC NON-REFLECTIVE
③	CENTERLINE / MEDIAN - 4" YELLOW RAISED PAVEMENT MARKERS, ACRYLIC DOUBLE REFLECTIVE AND CERAMIC NON-REFLECTIVE
④	RIGHT TURN ARROW SOLID WHITE ALKYD THERMOPLASTIC	↷
⑤	THRU / RIGHT TURN ARROW SOLID WHITE ALKYD THERMOPLASTIC	↷↶
⑥	LEFT TURN ARROW SOLID WHITE ALKYD THERMOPLASTIC	↶
⑦	THRU ONLY ARROW SOLID WHITE ALKYD THERMOPLASTIC	↶↷
⑧	STOP BAR 24" WIDE, WHITE ALKYD THERMOPLASTIC	—
⑨	"ONLY" LANE MARKING SOLID WHITE ALKYD THERMOPLASTIC	

NOTE: ALL ALKYD THERMOPLASTIC TO BE HOT-APPLIED.
 NOTE: ALL DIMENSIONS ARE TO BACK-OF-CURB.
 NOTE: PLACE TRAFFIC SIGNS TWO FEET CLEAR OF SIDEWALK OR AS DIRECTED BY THE ENGINEER.
 NOTE: ELEVATED SIGNAGE TO BE PROVIDED BY TOWN OF ADDISON.
 NOTE: MATERIAL SPECIFICATION PER TOWN OF ADDISON

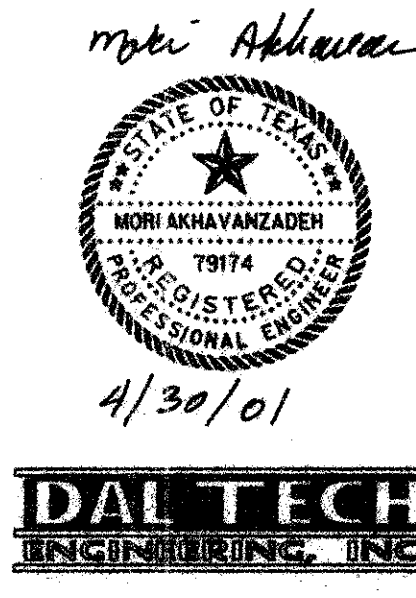
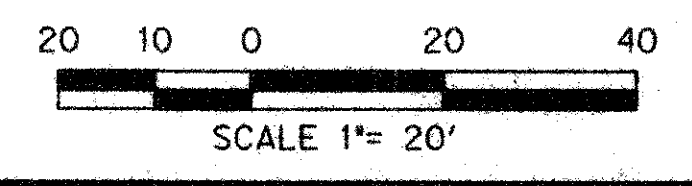

PAVEMENT MARKINGS						
KELLER SPRINGS ROAD						
from Addison Road to Dallas Parkway						
STREETS DIVISION						
TOWN OF ADDISON, TEXAS						
DESIGN	DRAWN	DATE	SCALE	NOTES	FILE	NO.
DTE	S.H.	APR 01	1"=20'			1/3

P:\#0106keller\traff\plan\st01.dwg 2001

p:\0106keller\traffic\plan\st01.mxd 2001

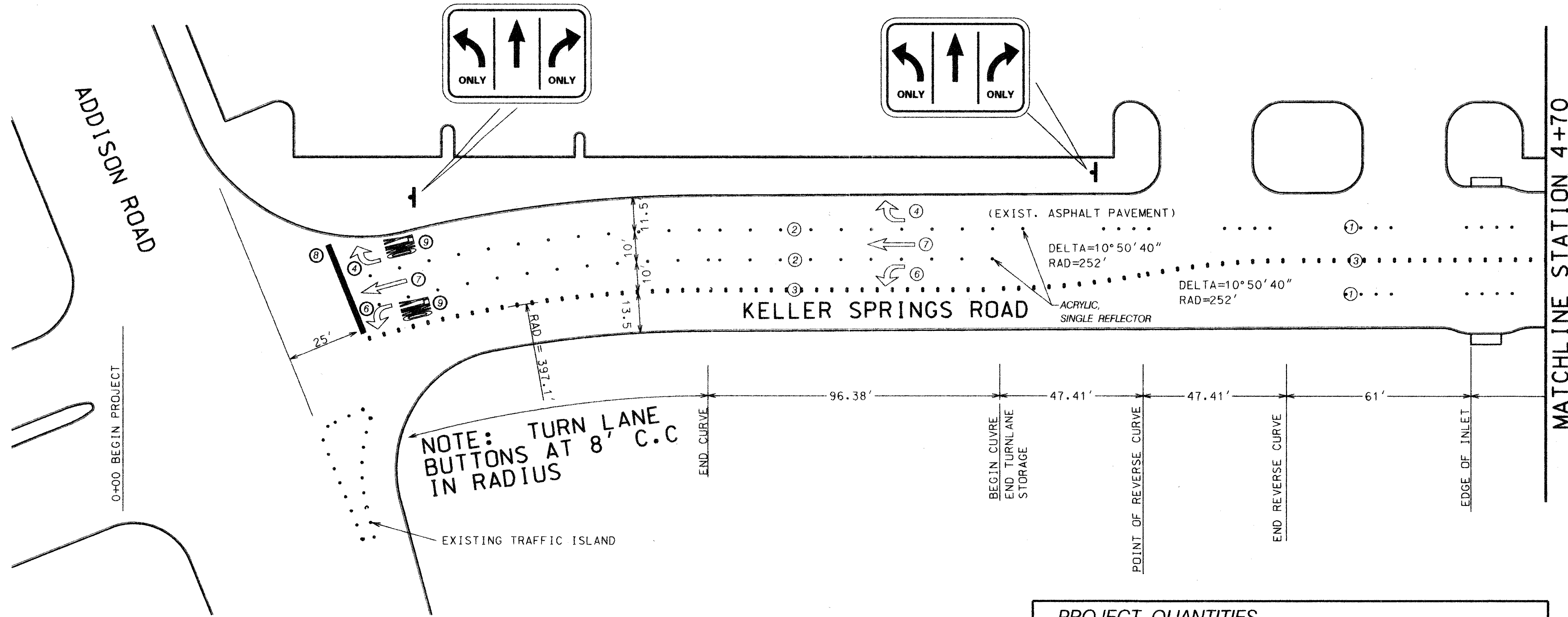

MATCHLINE STATION 4+70

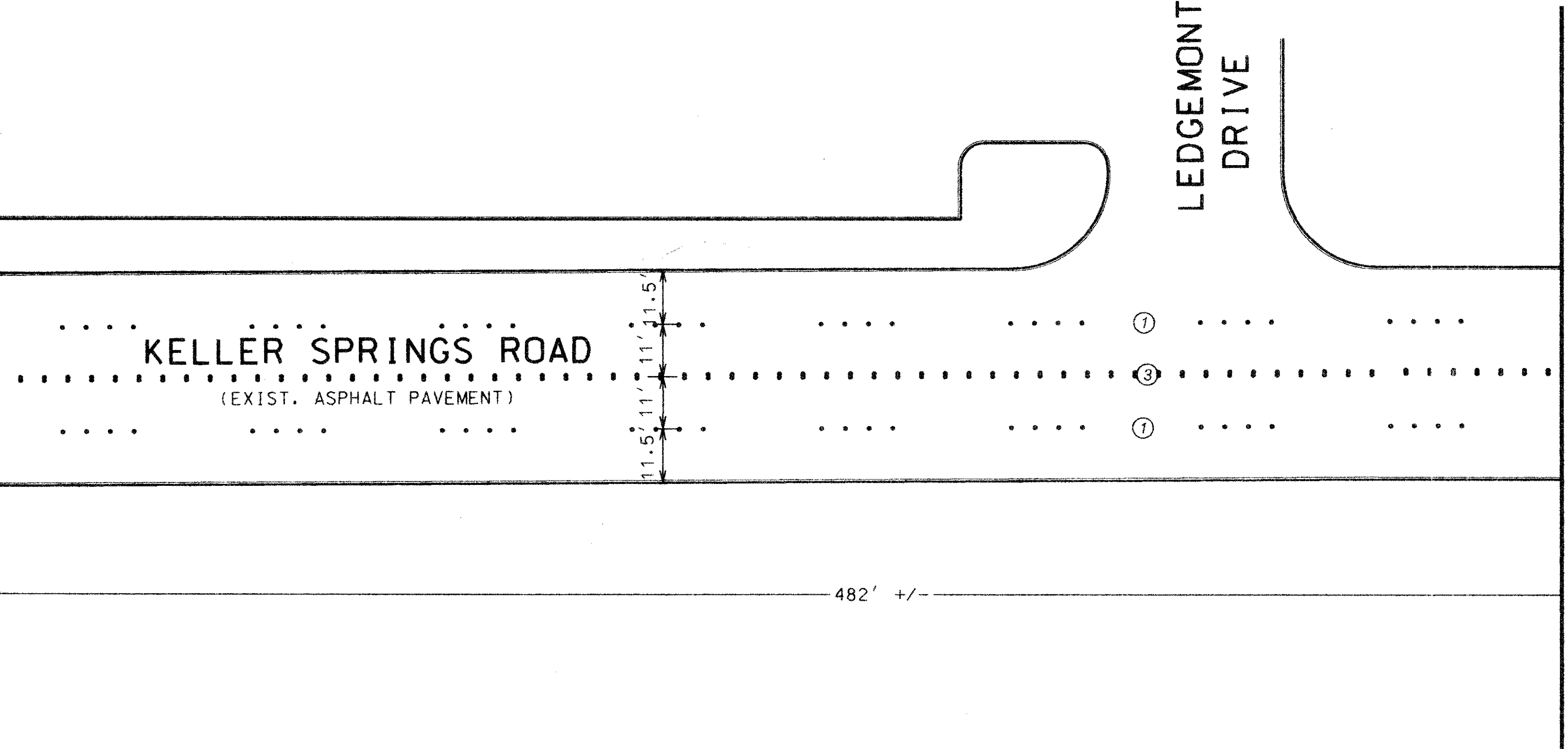

PROJECT QUANTITIES				
ITEM	DESCRIPTION	SYMBOL	UNIT	QUANTITY
1	4" WHITE, RAISED CERAMIC PAVEMENT MARKERS, NON-REFLECTIVE	○	EACH	330
2	4" WHITE, RAISED ACRYLIC PAVEMENT MARKERS, SINGLE REFLECTOR	◻	EACH	227
3	4" YELLOW, RAISED CERAMIC PAVEMENT MARKERS, NON-REFLECTIVE	○	EACH	777
4	4" YELLOW, RAISED ACRYLIC PAVEMENT MARKERS, DOUBLE REFLECTORS	◻	EACH	258
5	RIGHT TURN ARROW SOLID WHITE ALKYD THERMOPLASTIC	↷	EACH	4
6	THRU / RIGHT TURN ARROW SOLID WHITE ALKYD THERMOPLASTIC	↷↷	EACH	2
7	LEFT TURN ARROW SOLID WHITE ALKYD THERMOPLASTIC	↶	EACH	7
8	THRU ONLY ARROW SOLID WHITE ALKYD THERMOPLASTIC	↶↶	EACH	2
9	STOP BAR 24" WIDE, WHITE ALKYD THERMOPLASTIC	—	L.F.	168
10	"ONLY" LANE MARKING SOLID WHITE ALKYD THERMOPLASTIC		EACH	7
11	6" WIDE CROSSWALK STRIPE SOLID WHITE ALKYD THERMOPLASTIC	===	L.F.	565
12	REMOVE AND DISPOSE OF EXISTING 18" WIDE ALKYD THERMOPLASTIC	▨	L.F.	38

LEGEND		
①	LANE STRIPE - 4" WHITE RAISED PAVEMENT MARKERS, ACRYLIC SINGLE REFLECTIVE AND CERAMIC NON-REFLECTIVE
②	TURN LANE BAY DIVIDE - 4" WHITE, RAISED PAVEMENT MARKERS, ACRYLIC SINGLE REFLECTIVE AND CERAMIC NON-REFLECTIVE
③	CENTERLINE / MEDIAN - 4" YELLOW RAISED PAVEMENT MARKERS, ACRYLIC DOUBLE REFLECTIVE AND CERAMIC NON-REFLECTIVE
④	RIGHT TURN ARROW SOLID WHITE ALKYD THERMOPLASTIC	↷
⑤	THRU / RIGHT TURN ARROW SOLID WHITE ALKYD THERMOPLASTIC	↷↷
⑥	LEFT TURN ARROW SOLID WHITE ALKYD THERMOPLASTIC	↶
⑦	THRU ONLY ARROW SOLID WHITE ALKYD THERMOPLASTIC	↶↶
⑧	STOP BAR 24" WIDE, WHITE ALKYD THERMOPLASTIC	—
⑨	"ONLY" LANE MARKING SOLID WHITE ALKYD THERMOPLASTIC	

NOTE: ALL ALKYD THERMOPLASTIC TO BE HOT-APPLIED.
 NOTE: ALL DIMENSIONS ARE TO BACK-OF-CURB.
 NOTE: PLACE TRAFFIC SIGNS TWO FEET CLEAR OF SIDEWALK OR AS DIRECTED BY THE ENGINEER.
 NOTE: ELEVATED SIGNAGE TO BE PROVIDED BY TOWN OF ADDISON.
 NOTE: MATERIAL SPECIFICATION PER TOWN OF ADDISON

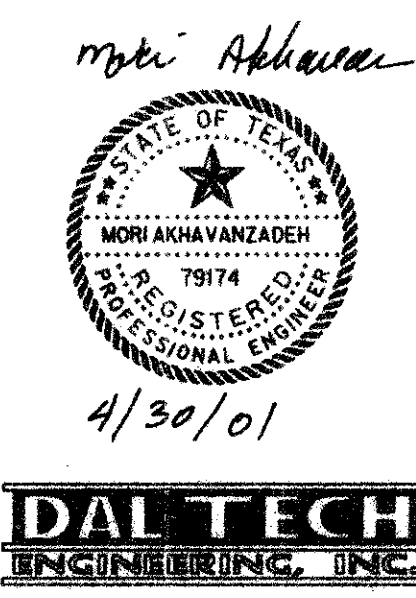
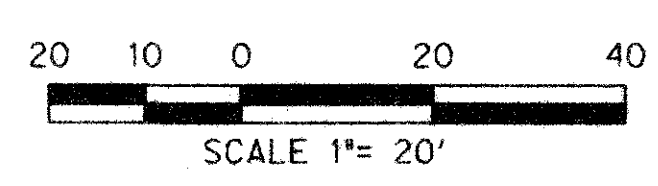

PAVEMENT MARKINGS							
KELLER SPRINGS ROAD							
from Addison Road to Dallas Parkway							
STREETS DIVISION							
TOWN OF ADDISON, TEXAS							
DESIGN	DRAWN	DATE	SCALE	NOTES	FILE	NO.	
DTE	S.H	APR 01	1"=20'				1/3

p:\#0106keller\tr\off\icp\lan\shp2\magn_2001

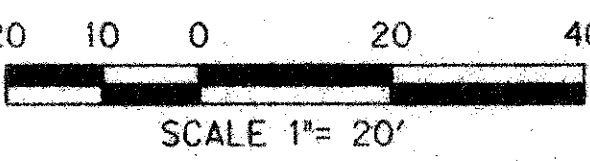
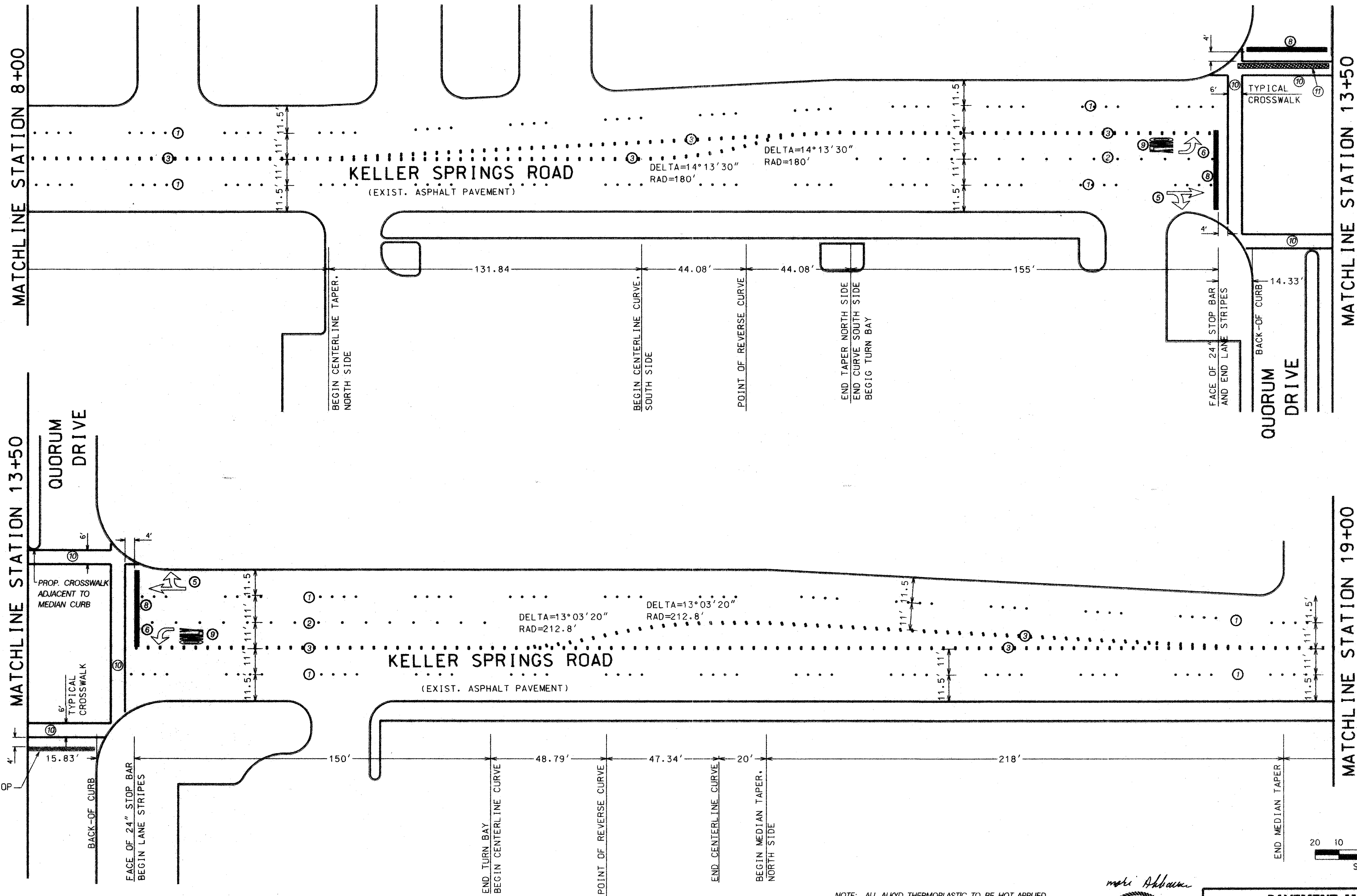

LEGEND	
①	LANE STRIPE - 4" WHITE RAISED PAVEMENT MARKERS, ACRYLIC SINGLE REFLECTIVE AND CERAMIC NON-REFLECTIVE
②	TURN LANE BAY DIVIDE - 4" WHITE, RAISED PAVEMENT MARKERS, ACRYLIC SINGLE REFLECTIVE AND CERAMIC NON-REFLECTIVE
③	CENTERLINE / MEDIAN - 4" YELLOW RAISED PAVEMENT MARKERS, ACRYLIC DOUBLE REFLECTIVE AND CERAMIC NON-REFLECTIVE
④	RIGHT TURN ARROW SOLID WHITE ALKYD THERMOPLASTIC
⑤	THRU / RIGHT TURN ARROW SOLID WHITE ALKYD THERMOPLASTIC
⑥	LEFT TURN ARROW SOLID WHITE ALKYD THERMOPLASTIC
⑦	THRU ONLY ARROW SOLID WHITE ALKYD THERMOPLASTIC
⑧	STOP BAR 24" WIDE, WHITE ALKYD THERMOPLASTIC
⑨	"ONLY" LANE MARKING SOLID WHITE ALKYD THERMOPLASTIC
⑩	6" WIDE CROSSWALK MARKING SOLID WHITE ALKYD THERMOPLASTIC
⑪	REMOVE AND DISPOSE OF EXISTING 18" WIDE ALKYD THERMOPLASTIC

NOTE: ALL ALKYD THERMOPLASTIC TO BE HOT-APPLIED.
 NOTE: ALL DIMENSIONS ARE TO BACK-OF-CURB.
 NOTE: PLACE TRAFFIC SIGNS TWO FEET CLEAR OF SIDEWALK OR AS DIRECTED BY THE ENGINEER.
 NOTE: ELEVATED SIGNAGE TO BE PROVIDED BY TOWN OF ADDISON.
 NOTE: MATERIAL SPECIFICATION PER TOWN OF ADDISON

Mohi Abbas

4/30/01

DAL TECH
ENGINEERING, INC.

PAVEMENT MARKINGS						
KELLER SPRINGS ROAD						
from Addison Road to Dallas Parkway						
STREETS DIVISION						
TOWN OF ADDISON, TEXAS						
DESIGN	DRAWN	DATE	SCALE	NOTES	FILE	NO.
DTE	S.H	APR 01	1"=20'			2/3

p:\0106keller\traffic\plan\st02.dwg 2001

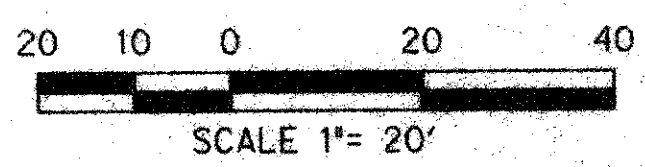
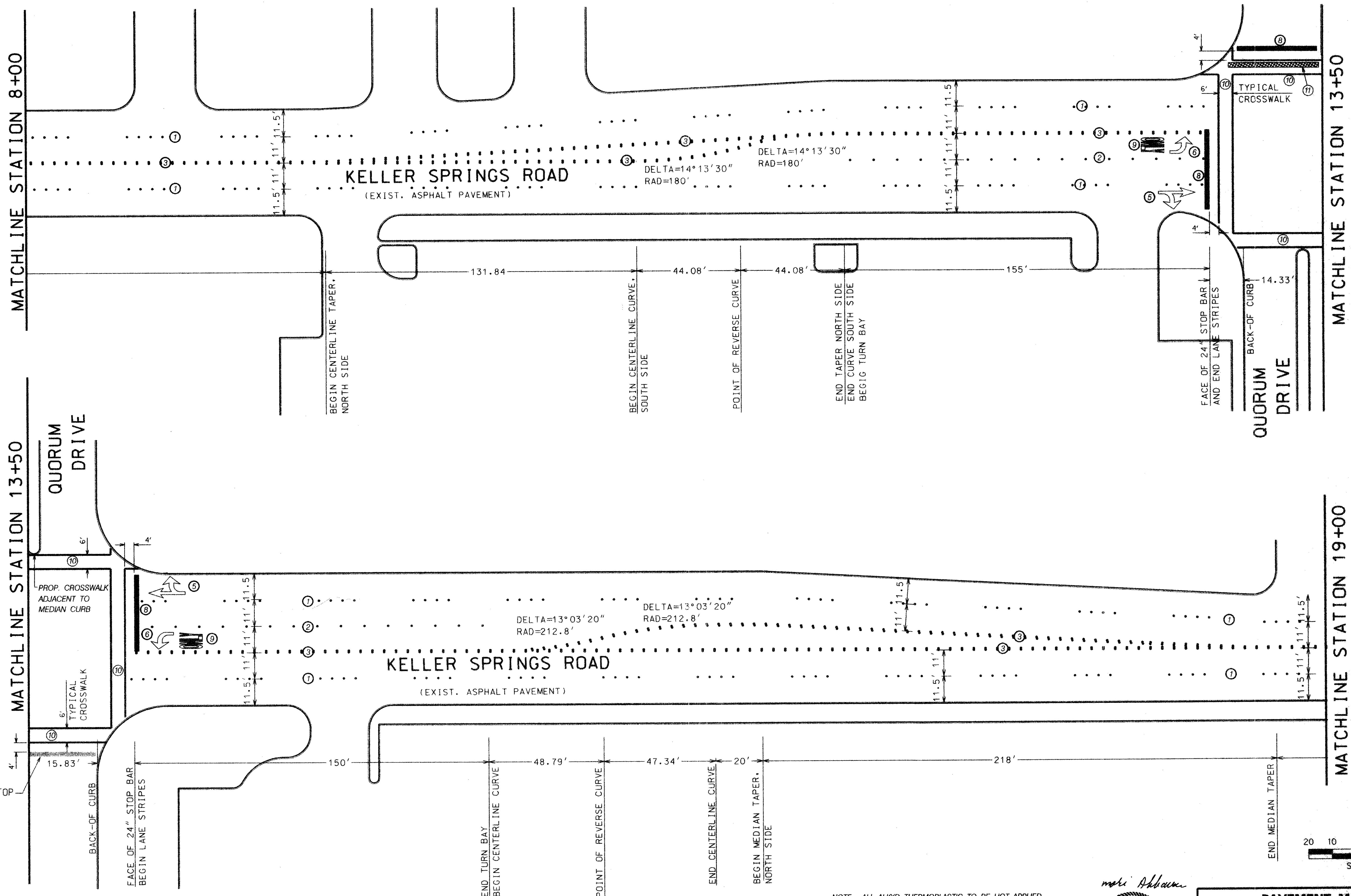

Mohi Abbas

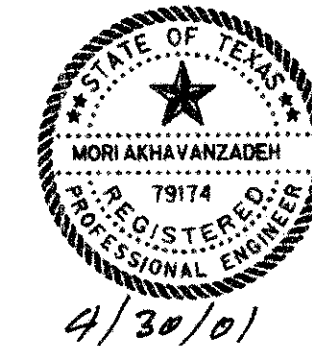

- NOTE: ALL ALKYD THERMOPLASTIC TO BE HOT-APPLIED.
- NOTE: ALL DIMENSIONS ARE TO BACK-OF-CURB.
- NOTE: PLACE TRAFFIC SIGNS TWO FEET CLEAR OF SIDEWALK OR AS DIRECTED BY THE ENGINEER.
- NOTE: ELEVATED SIGNAGE TO BE PROVIDED BY TOWN OF ADDISON.
- NOTE: MATERIAL SPECIFICATION PER TOWN OF ADDISON

LEGEND	
①	LANE STRIPE - 4" WHITE RAISED PAVEMENT MARKERS, ACRYLIC SINGLE REFLECTIVE AND CERAMIC NON-REFLECTIVE
②	TURN LANE BAY DIVIDE - 4" WHITE, RAISED PAVEMENT MARKERS, ACRYLIC SINGLE REFLECTIVE AND CERAMIC NON-REFLECTIVE
③	CENTERLINE / MEDIAN - 4" YELLOW RAISED PAVEMENT MARKERS, ACRYLIC DOUBLE REFLECTIVE AND CERAMIC NON-REFLECTIVE
④	RIGHT TURN ARROW SOLID WHITE ALKYD THERMOPLASTIC
⑤	THRU / RIGHT TURN ARROW SOLID WHITE ALKYD THERMOPLASTIC
⑥	LEFT TURN ARROW SOLID WHITE ALKYD THERMOPLASTIC
⑦	THRU ONLY ARROW SOLID WHITE ALKYD THERMOPLASTIC
⑧	STOP BAR 24" WIDE, WHITE ALKYD THERMOPLASTIC
⑨	"ONLY" LANE MARKING SOLID WHITE ALKYD THERMOPLASTIC
⑩	6" WIDE CROSSWALK MARKING SOLID WHITE ALKYD THERMOPLASTIC
⑪	REMOVE AND DISPOSE OF EXISTING 18" WIDE ALKYD THERMOPLASTIC

PAVEMENT MARKINGS						
KELLER SPRINGS ROAD						
from Addison Road to Dallas Parkway						
STREETS DIVISION						
TOWN OF ADDISON, TEXAS						
DESIGN	DRAWN	DATE	SCALE	NOTES	FILE	NO.
DTE	S.H	APR 01	1"=20'			2 / 3

p:\0106keller\traff\plan\sh3.dgn 01 MAY 2001

MATCHLINE STATION 19+00

MATCHLINE STATION 21+00

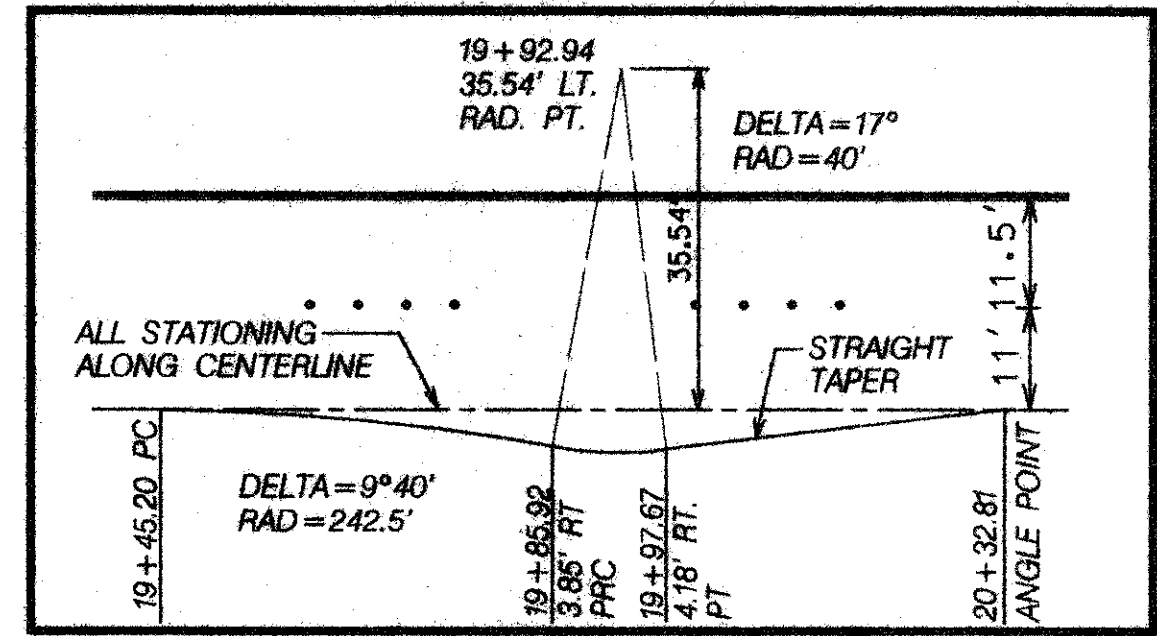
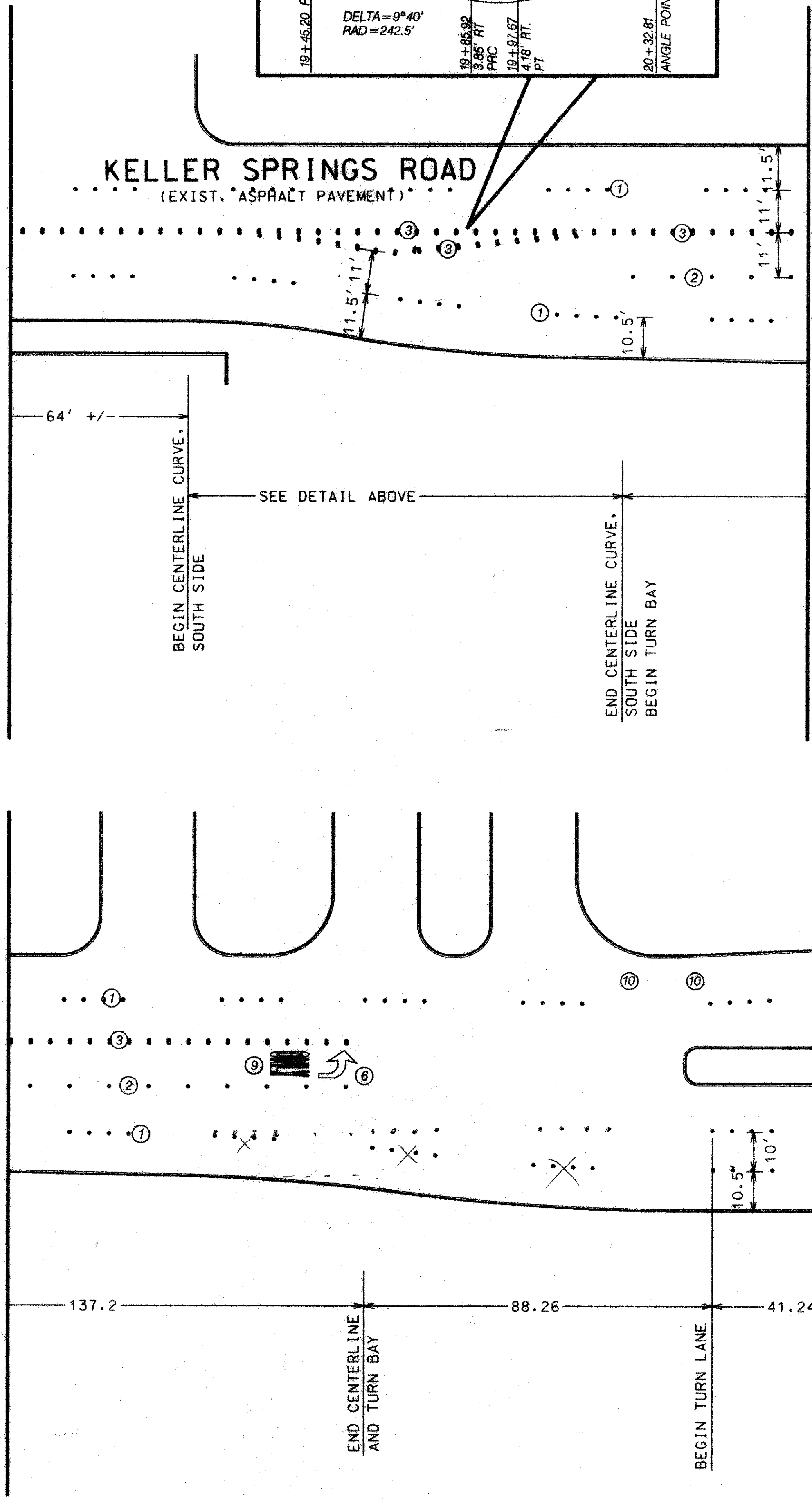

MATCHLINE STATION 21+00

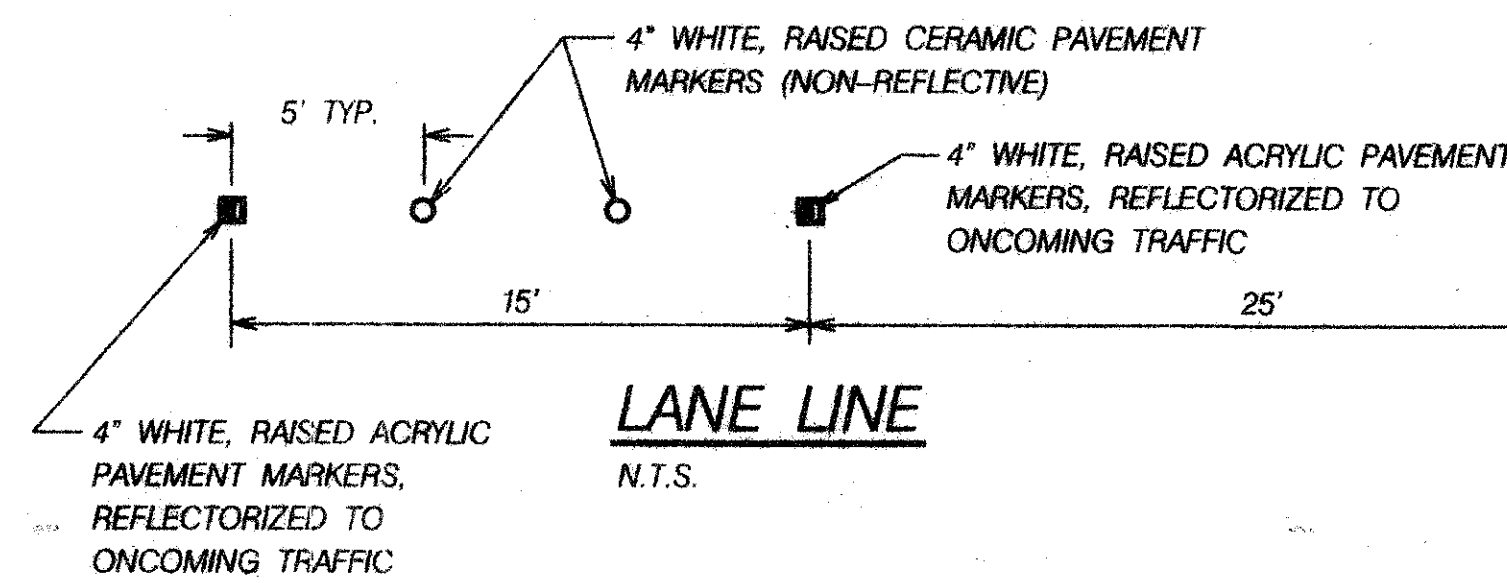
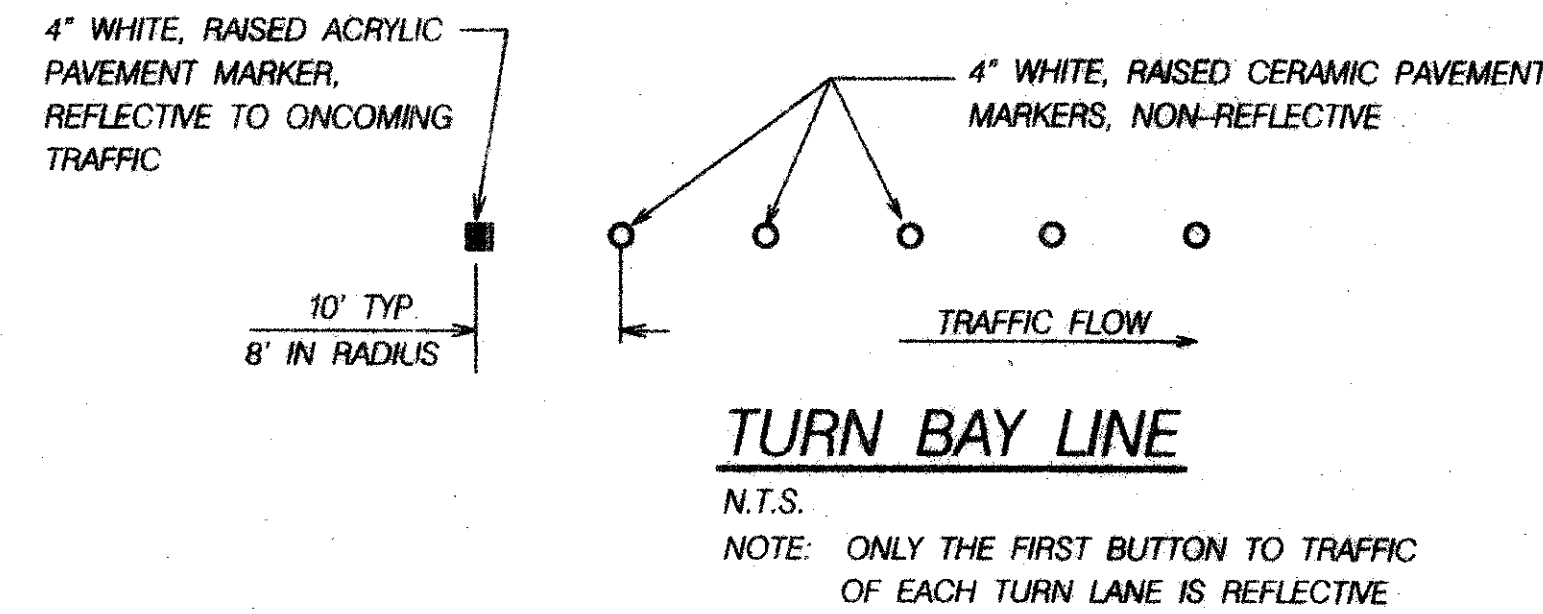
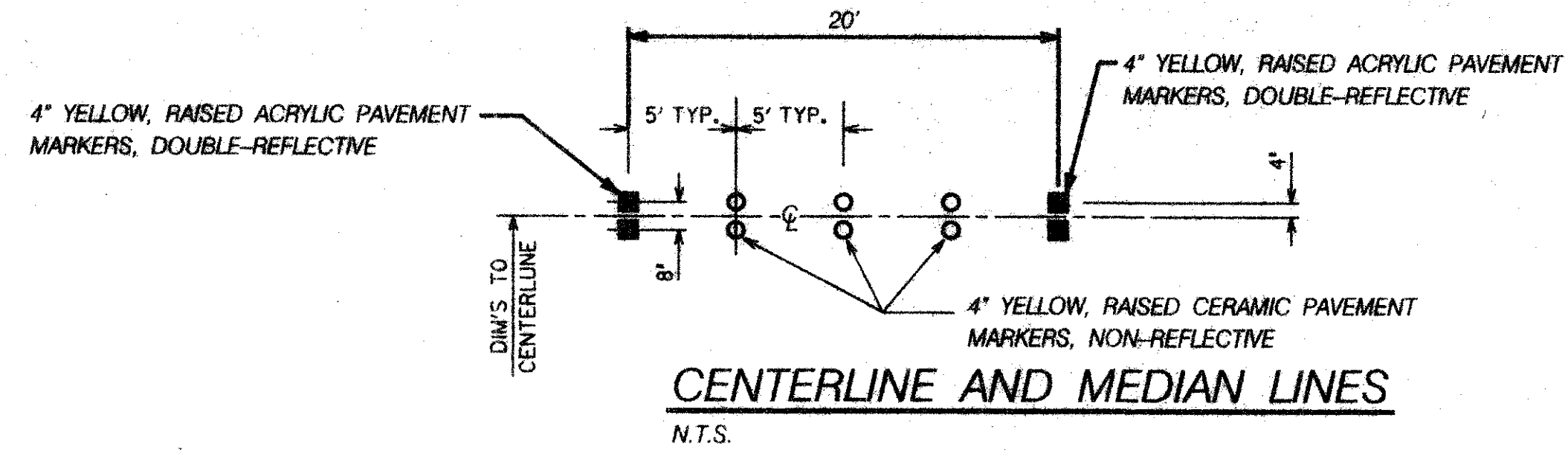

LEGEND	
①	LANE STRIPE - 4" WHITE RAISED PAVEMENT MARKERS, ACRYLIC SINGLE REFLECTIVE AND CERAMIC NON-REFLECTIVE
②	TURN LANE BAY DIVIDE - 4" WHITE, RAISED PAVEMENT MARKERS, ACRYLIC SINGLE REFLECTIVE AND CERAMIC NON-REFLECTIVE
③	CENTERLINE / MEDIAN - 4" YELLOW RAISED PAVEMENT MARKERS, ACRYLIC DOUBLE REFLECTIVE AND CERAMIC NON-REFLECTIVE
④	RIGHT TURN ARROW SOLID WHITE ALKYD THERMOPLASTIC
⑤	THRU / RIGHT TURN ARROW SOLID WHITE ALKYD THERMOPLASTIC
⑥	LEFT TURN ARROW SOLID WHITE ALKYD THERMOPLASTIC
⑦	THRU ONLY ARROW SOLID WHITE ALKYD THERMOPLASTIC
⑧	STOP BAR 24" WIDE, WHITE ALKYD THERMOPLASTIC
⑨	"ONLY" LANE MARKING SOLID WHITE ALKYD THERMOPLASTIC

DALLAS PARKWAY

26+00 END PROJECT

- NOTE: ALL ALKYD THERMOPLASTIC TO BE HOT-APPLIED.
- NOTE: ALL DIMENSIONS ARE TO BACK-OF-CURB.
- NOTE: PLACE TRAFFIC SIGNS TWO FEET CLEAR OF SIDEWALK OR AS DIRECTED BY THE ENGINEER.
- NOTE: ELEVATED SIGNAGE TO BE PROVIDED BY TOWN OF ADDISON.
- NOTE: MATERIAL SPECIFICATION PER TOWN OF ADDISON

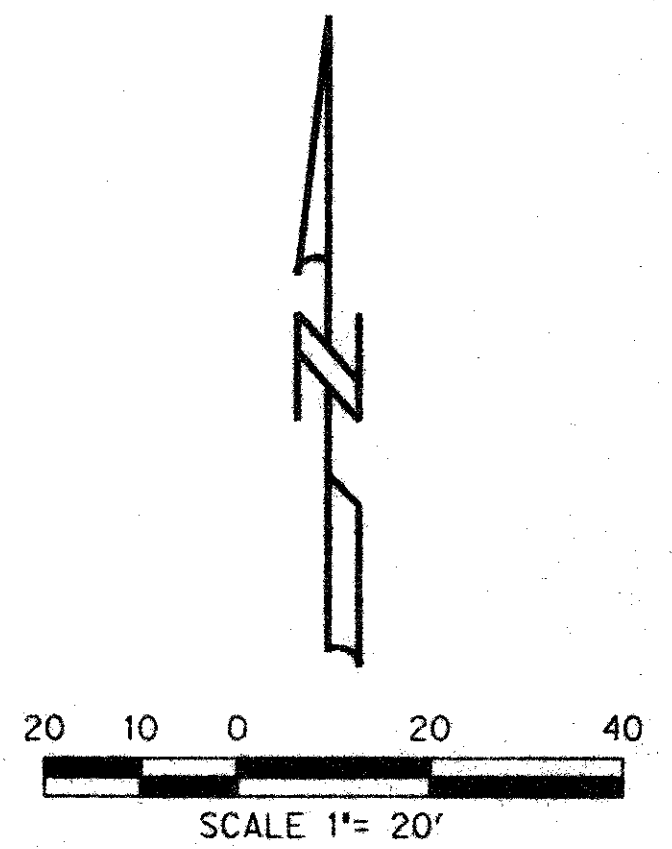

KELLER SPRINGS ROAD
(EXIST. ASPHALT PAVEMENT)

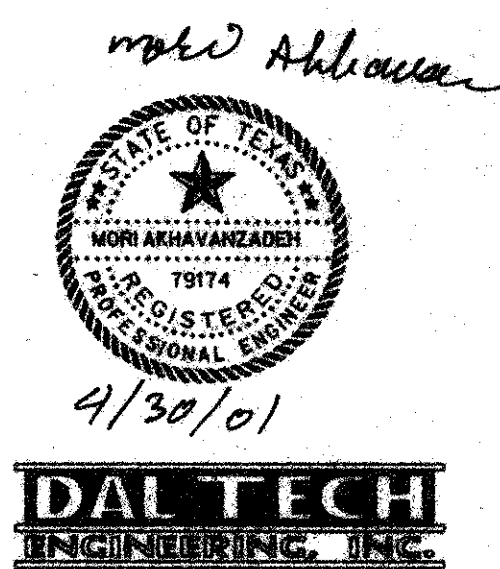
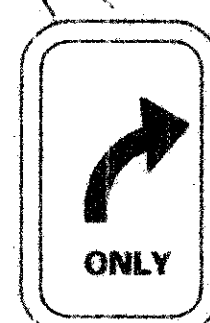

PAVEMENT MARKINGS						
KELLER SPRINGS ROAD						
from Addison Road to Dallas Parkway						
STREETS DIVISION						
TOWN OF ADDISON, TEXAS						
DESIGN	DRAWN	DATE	SCALE	NOTES	FILE	NO.
DTE	S.H.	APR 01	1"=20'			3/3

p:\0106keller\tr\off\plan\sh3.dgn 01 MAY 2001

MATCHLINE STATION 19+00

MATCHLINE STATION 21+00

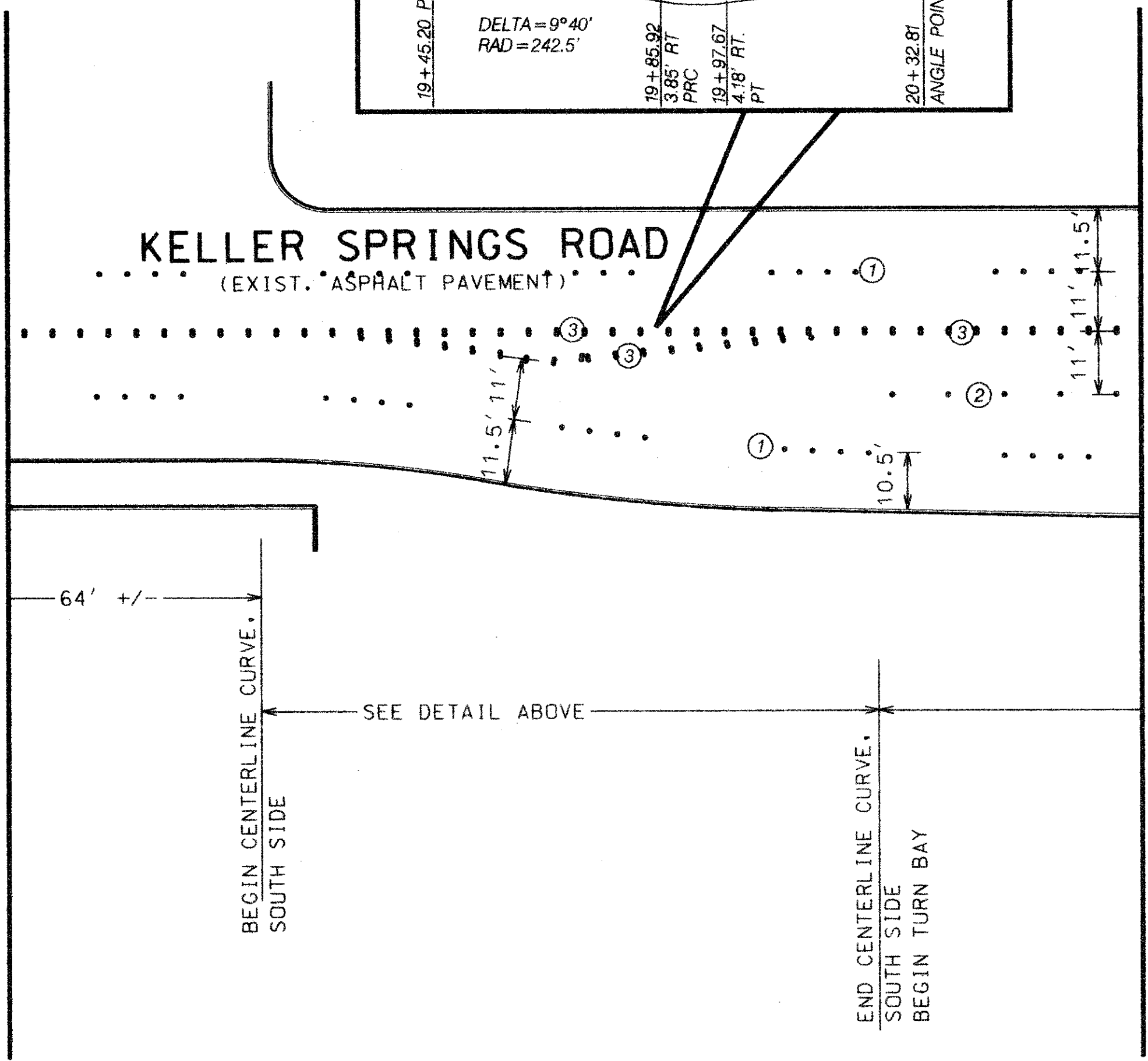

MATCHLINE STATION 21+00

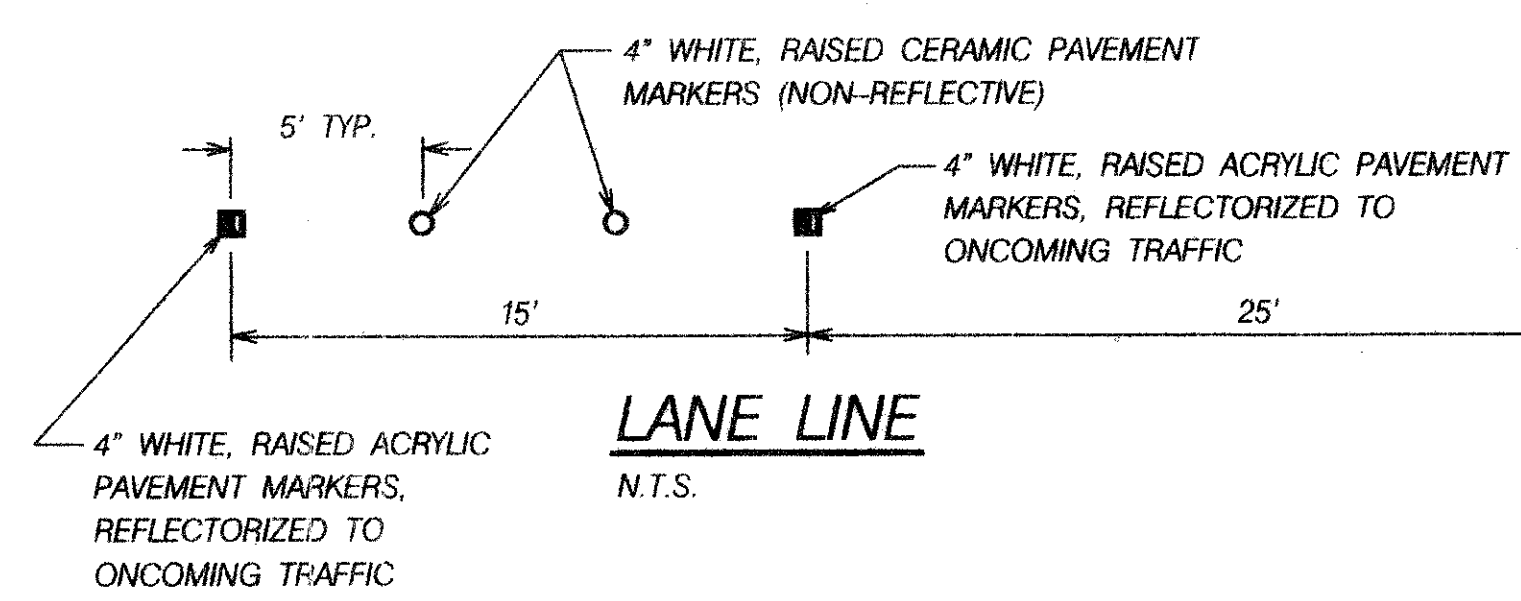
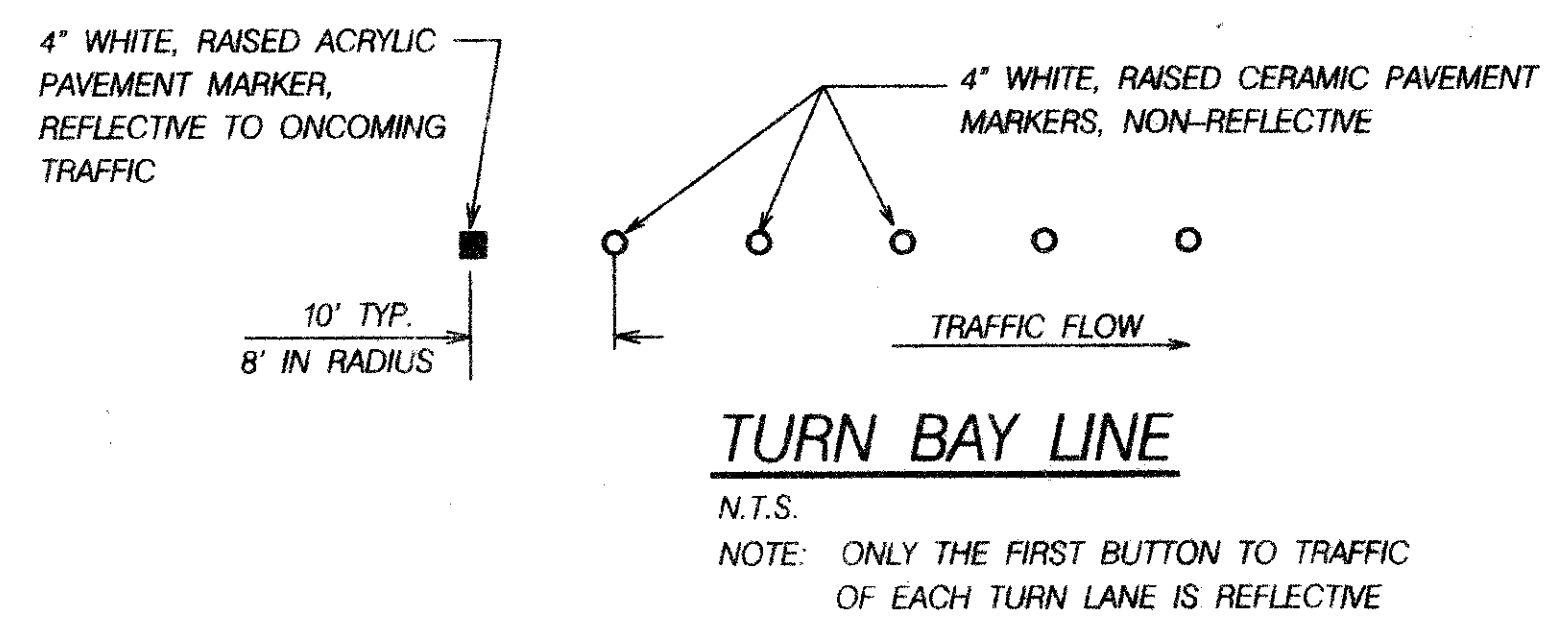
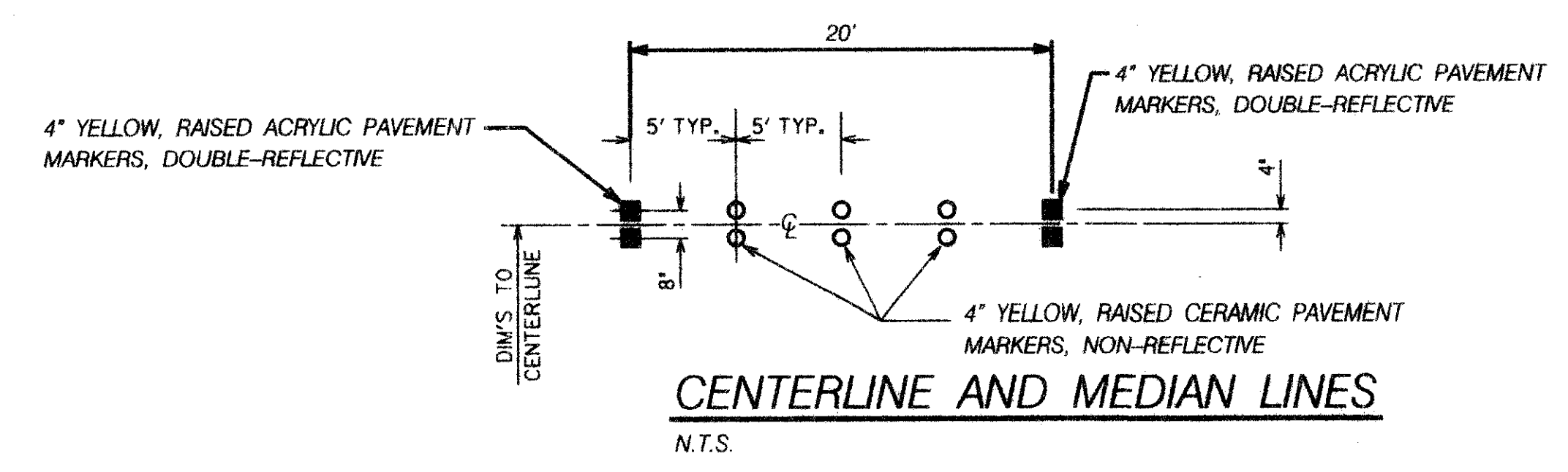
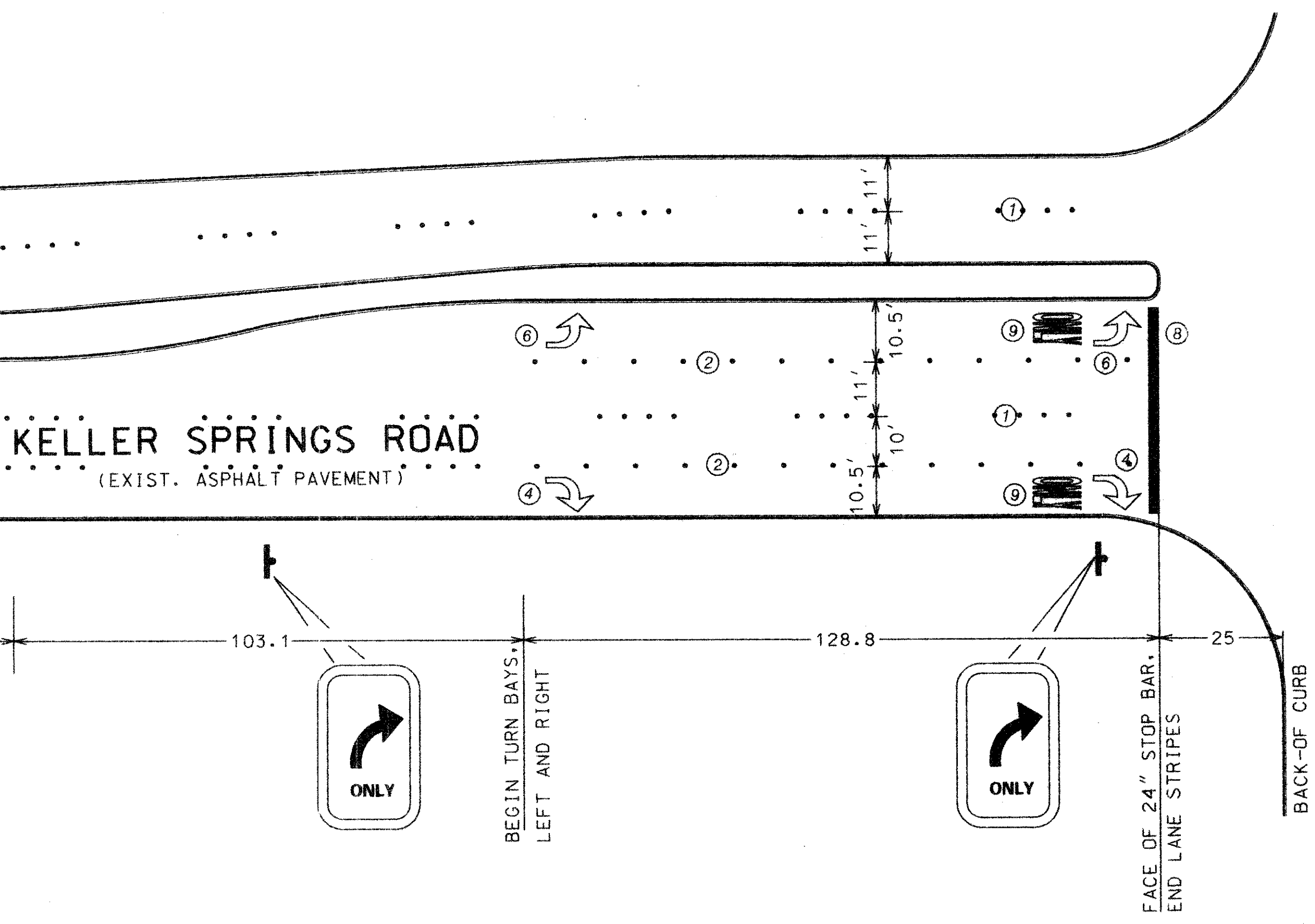

LEGEND	
①	LANE STRIPE - 4" WHITE RAISED PAVEMENT MARKERS, ACRYLIC SINGLE REFLECTIVE AND CERAMIC NON-REFLECTIVE
②	TURN LANE BAY DIVIDE - 4" WHITE, RAISED PAVEMENT MARKERS, ACRYLIC SINGLE REFLECTIVE AND CERAMIC NON-REFLECTIVE
③	CENTERLINE / MEDIAN - 4" YELLOW RAISED PAVEMENT MARKERS, ACRYLIC DOUBLE REFLECTIVE AND CERAMIC NON-REFLECTIVE
④	RIGHT TURN ARROW SOLID WHITE ALKYD THERMOPLASTIC
⑤	THRU / RIGHT TURN ARROW SOLID WHITE ALKYD THERMOPLASTIC
⑥	LEFT TURN ARROW SOLID WHITE ALKYD THERMOPLASTIC
⑦	THRU ONLY ARROW SOLID WHITE ALKYD THERMOPLASTIC
⑧	STOP BAR 24" WIDE, WHITE ALKYD THERMOPLASTIC
⑨	"ONLY" LANE MARKING SOLID WHITE ALKYD THERMOPLASTIC

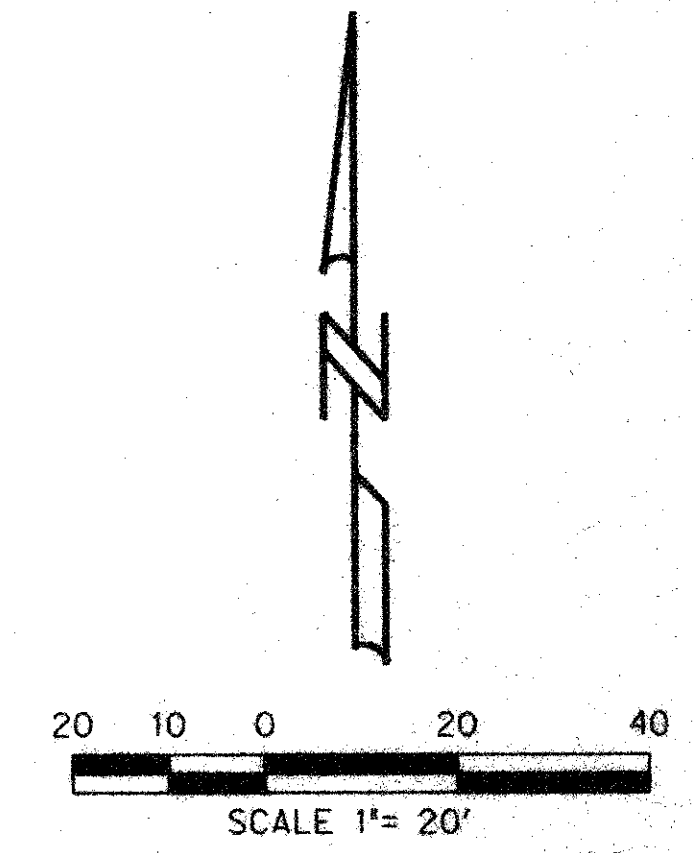

DALLAS PARKWAY

26+00 END PROJECT

- NOTE: ALL ALKYD THERMOPLASTIC TO BE HOT-APPLIED.
- NOTE: ALL DIMENSIONS ARE TO BACK-OF-CURB.
- NOTE: PLACE TRAFFIC SIGNS TWO FEET CLEAR OF SIDEWALK OR AS DIRECTED BY THE ENGINEER.
- NOTE: ELEVATED SIGNAGE TO BE PROVIDED BY TOWN OF ADDISON.
- NOTE: MATERIAL SPECIFICATION PER TOWN OF ADDISON

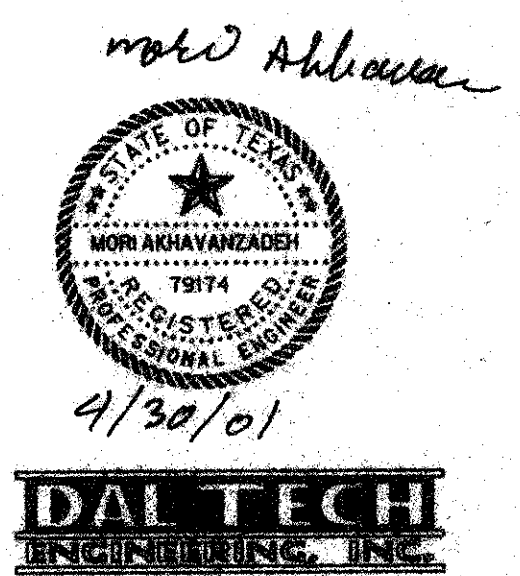

PAVEMENT MARKINGS						
KELLER SPRINGS ROAD						
from Addison Road to Dallas Parkway						
STREETS DIVISION						
TOWN OF ADDISON, TEXAS						
DESIGN	DRAWN	DATE	SCALE	NOTES	FILE	NO.
DTE	SH	APR 01	1"=20'			3/3