

R4-7b  
24" X 30"  
Letters - Black  
Symbol - Black  
Border - Black  
Background - White Refl.

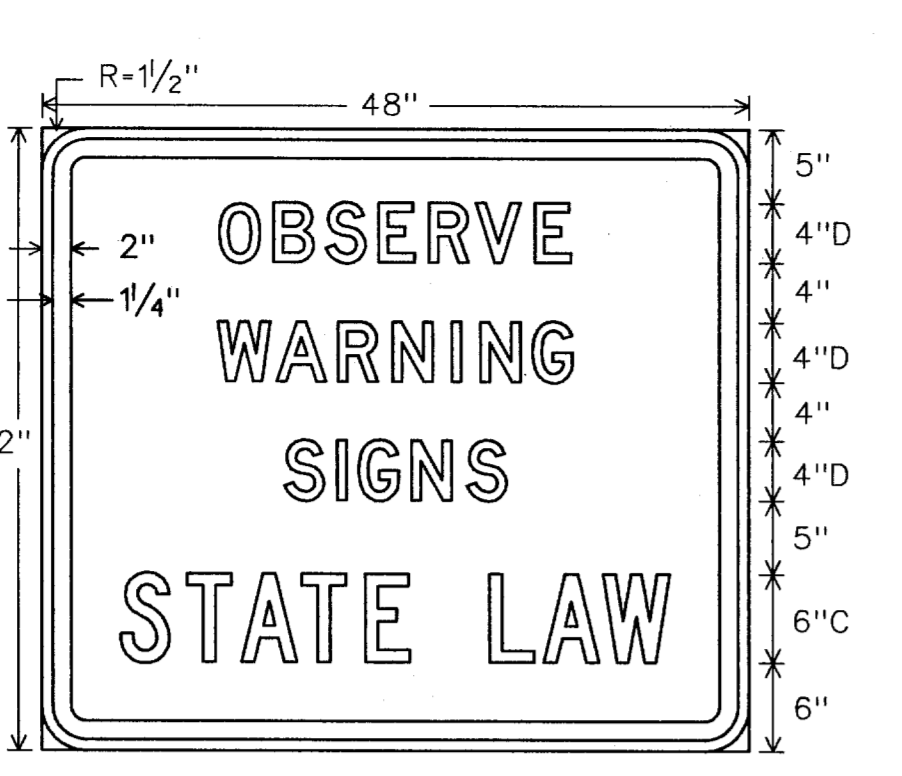

R20-3  
48" X 42"  
Letters - Black  
Border - Black  
Background - White Refl.

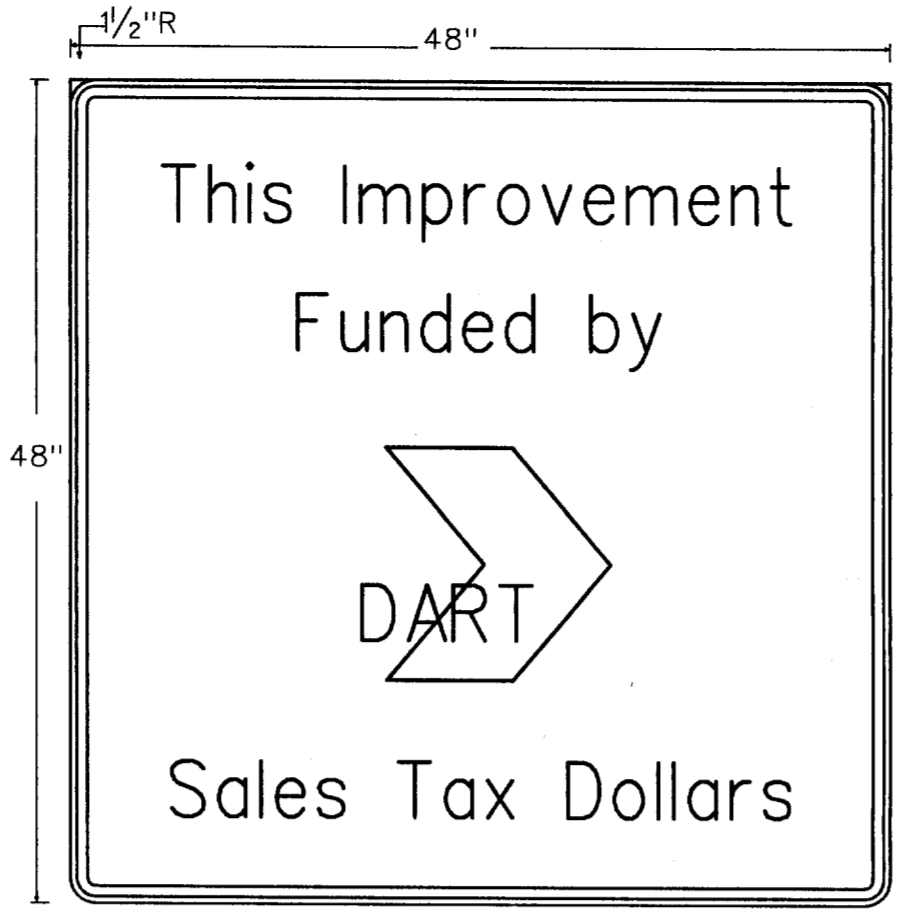

48" X 48"  
Letters - Navy Blue  
DART Symbol - Yellow  
Background - White Refl.

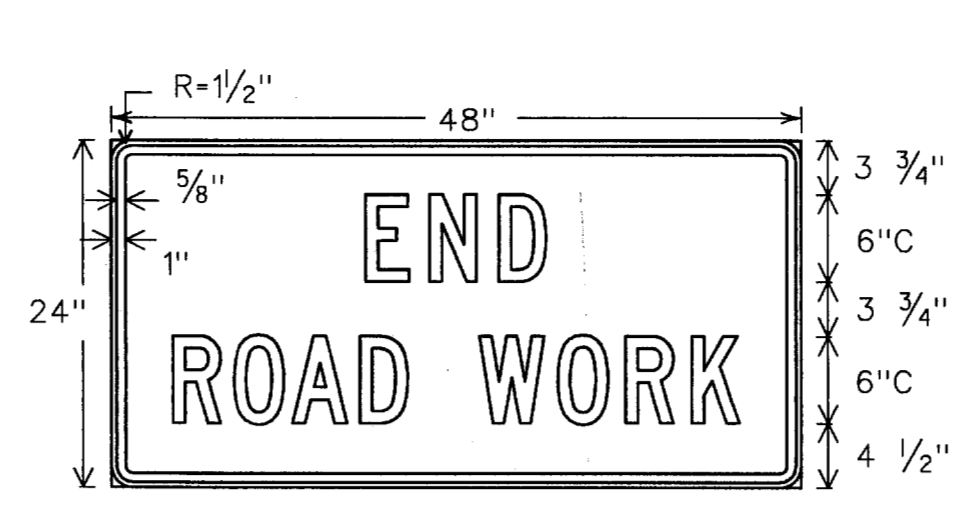

G20-2a  
48" X 24"  
Letters - Black  
Border - Black  
Background - Orange Refl.

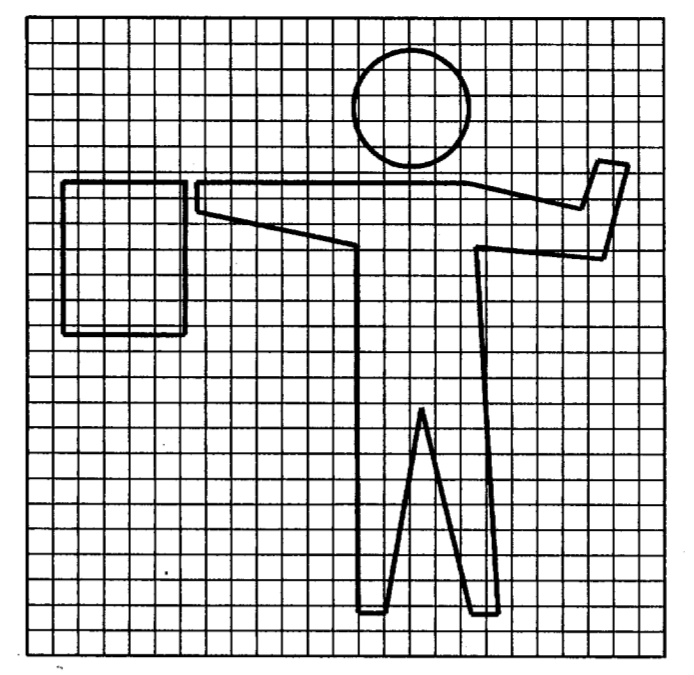

R4-8b

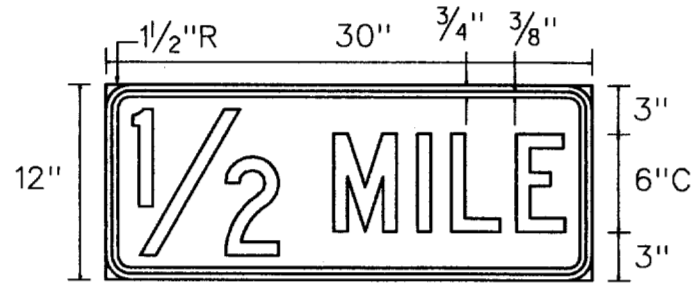

Distance Plaque  
30" X 12"

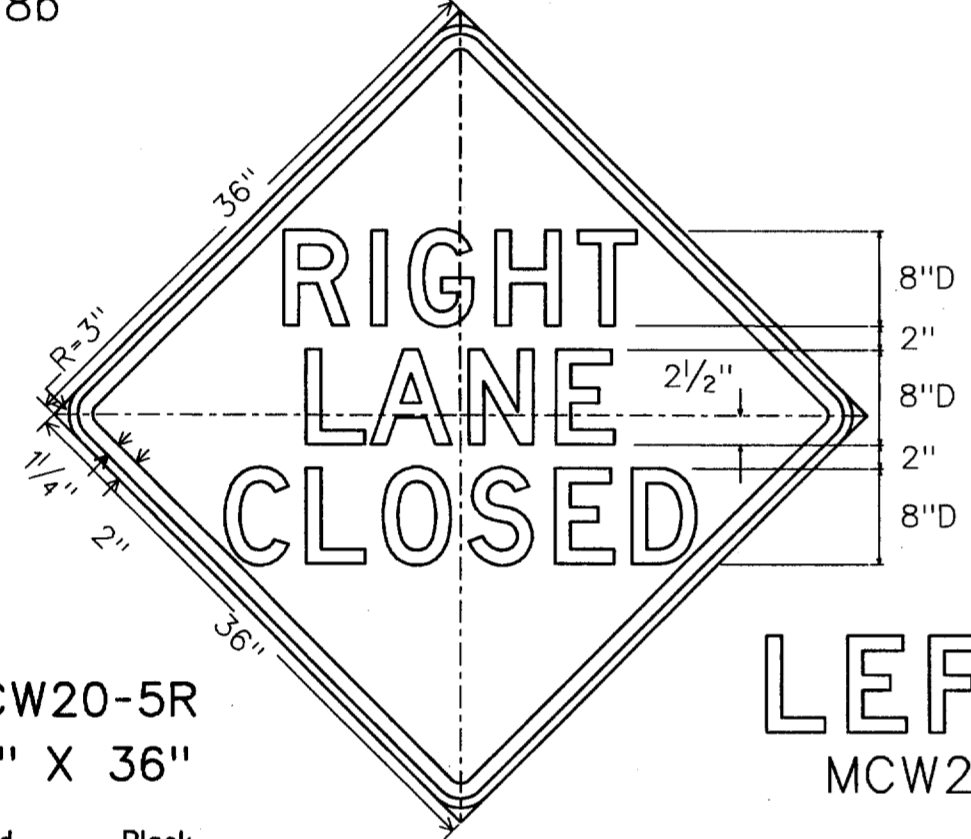

MCW20-5R  
36" X 36"  
Legend - Black  
Border - Black  
Background - Orange Refl.



MCW20-5L

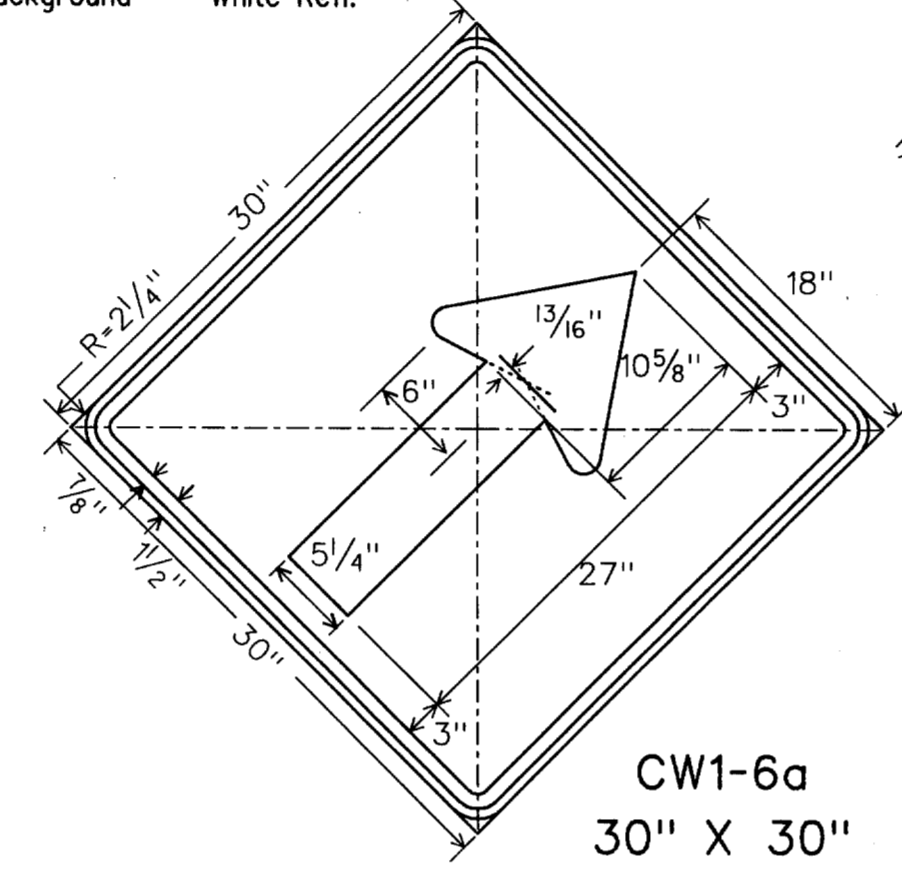
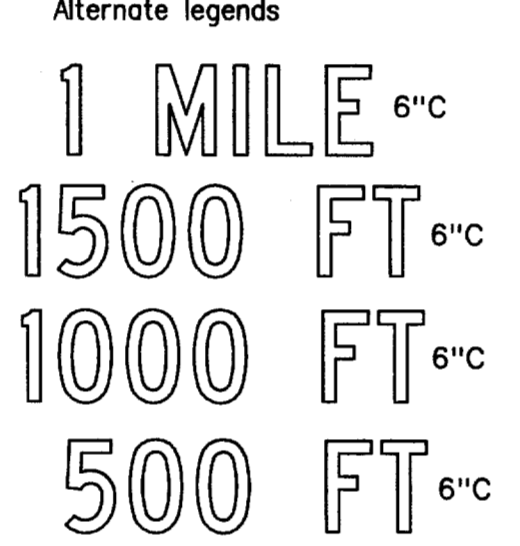

CW1-6a  
30" X 30"  
Legend - Black  
Border - Black  
Background - Orange Refl.

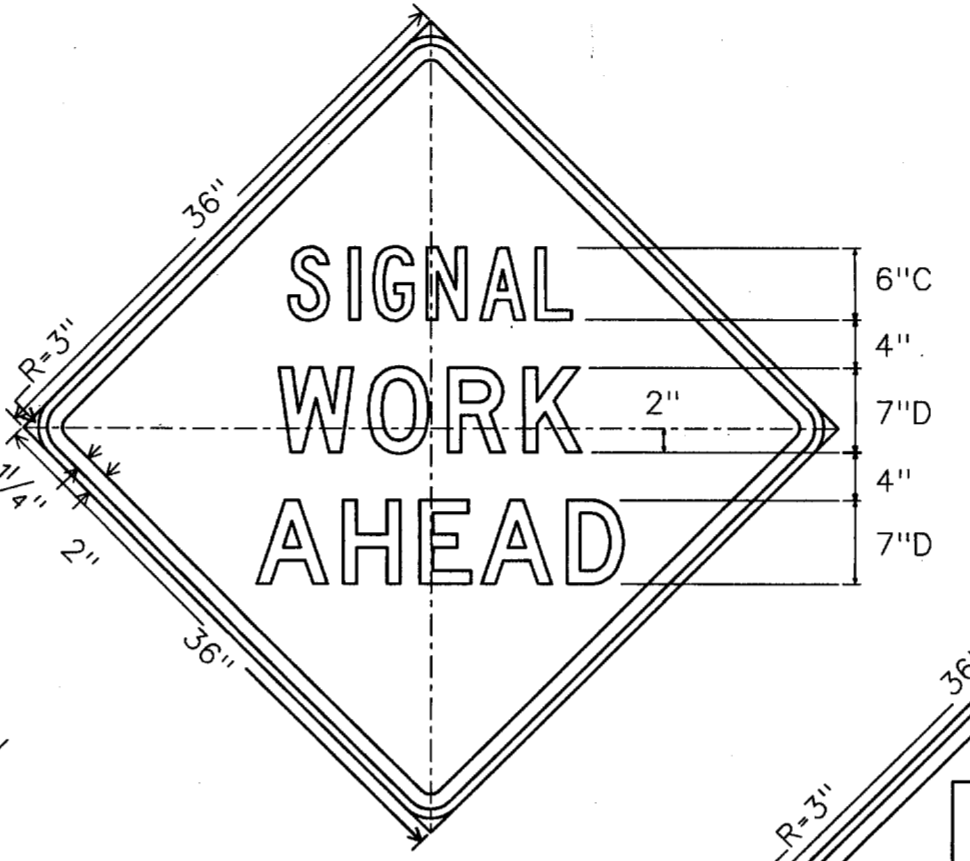

MCW20SG-1D  
36" X 36"  
Letters - Black  
Border - Black  
Background - Orange Refl.

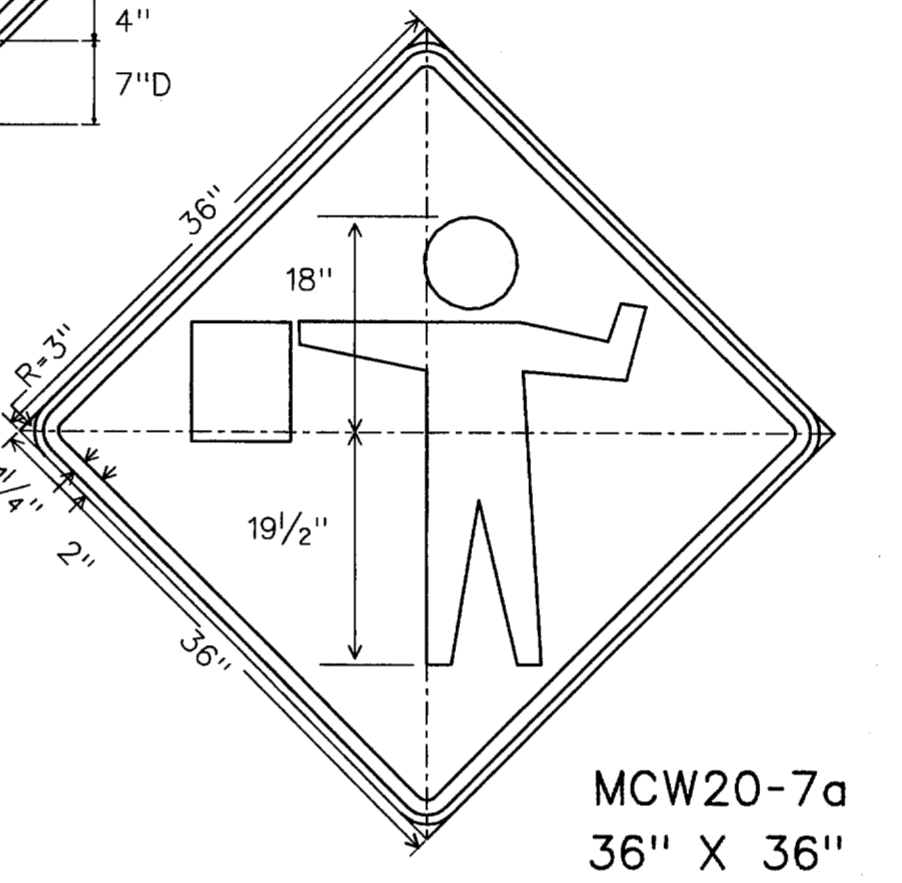

MCW20-7a  
36" X 36"  
Legend - Black  
Border - Black  
Background - Orange Refl.

TYPICAL SIGNS USED IN TRAFFIC SIGNAL CONSTRUCTION AREAS

TYPE I BARRICADES

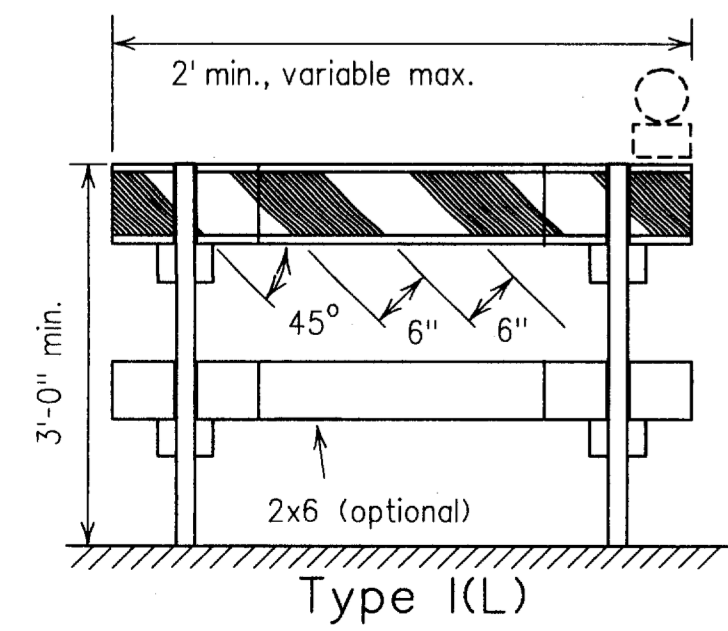
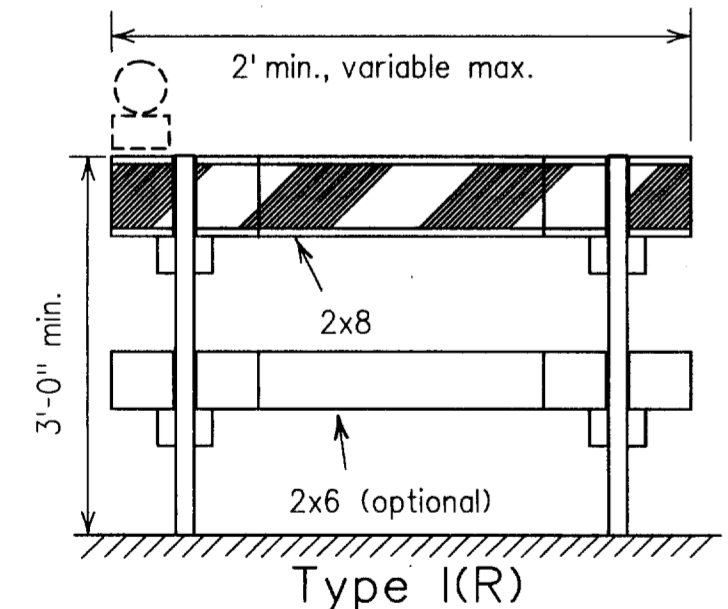

For Type I and II Barricades, both sides of the rails shall have reflective orange and reflective white striping.

TYPICAL SIGN SUPPORTS

FIXED SUPPORTS

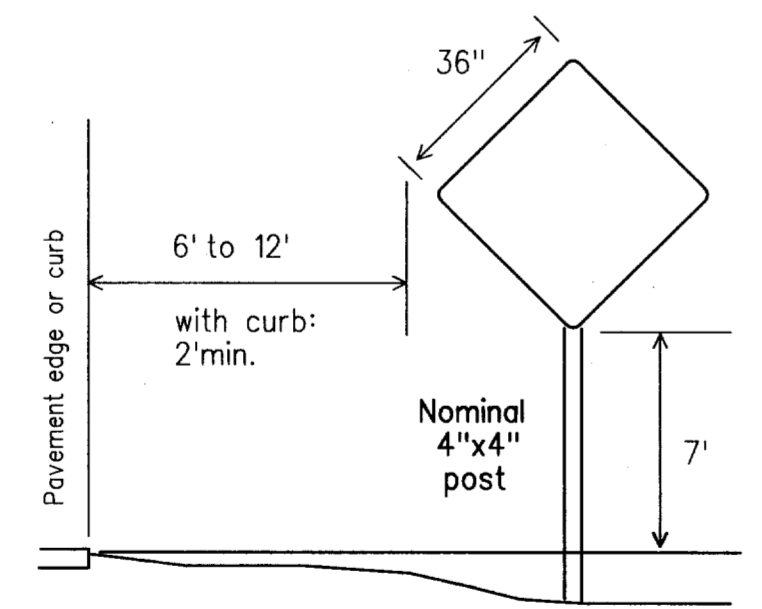

WOOD POST SIGN SUPPORT: for 36" x 36" and smaller warning signs, and other signs having an area not exceeding 10 sq.ft.

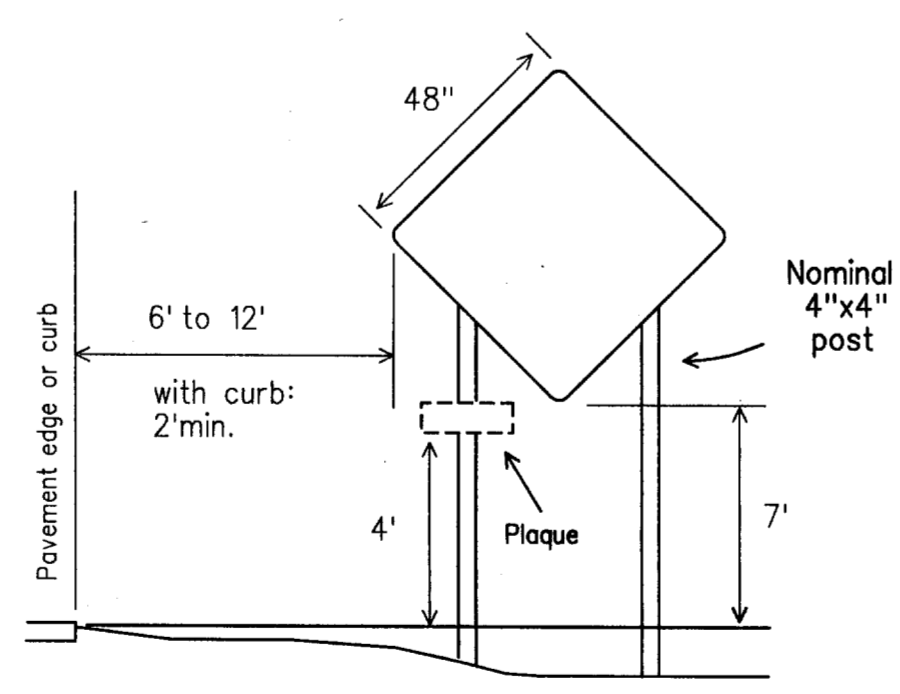

WOOD POST SIGN SUPPORT: for 48" x 48" warning sign.

Signs erected on fixed supports shall be at a minimum height of 7 feet. Embedment depth for wood sign supports and post type barricades should be 3 feet minimum, unless specified elsewhere in the plans. Driveable sign supports may be used and shall be installed in accordance with the manufacturers recommendations.

PORTABLE SUPPORTS

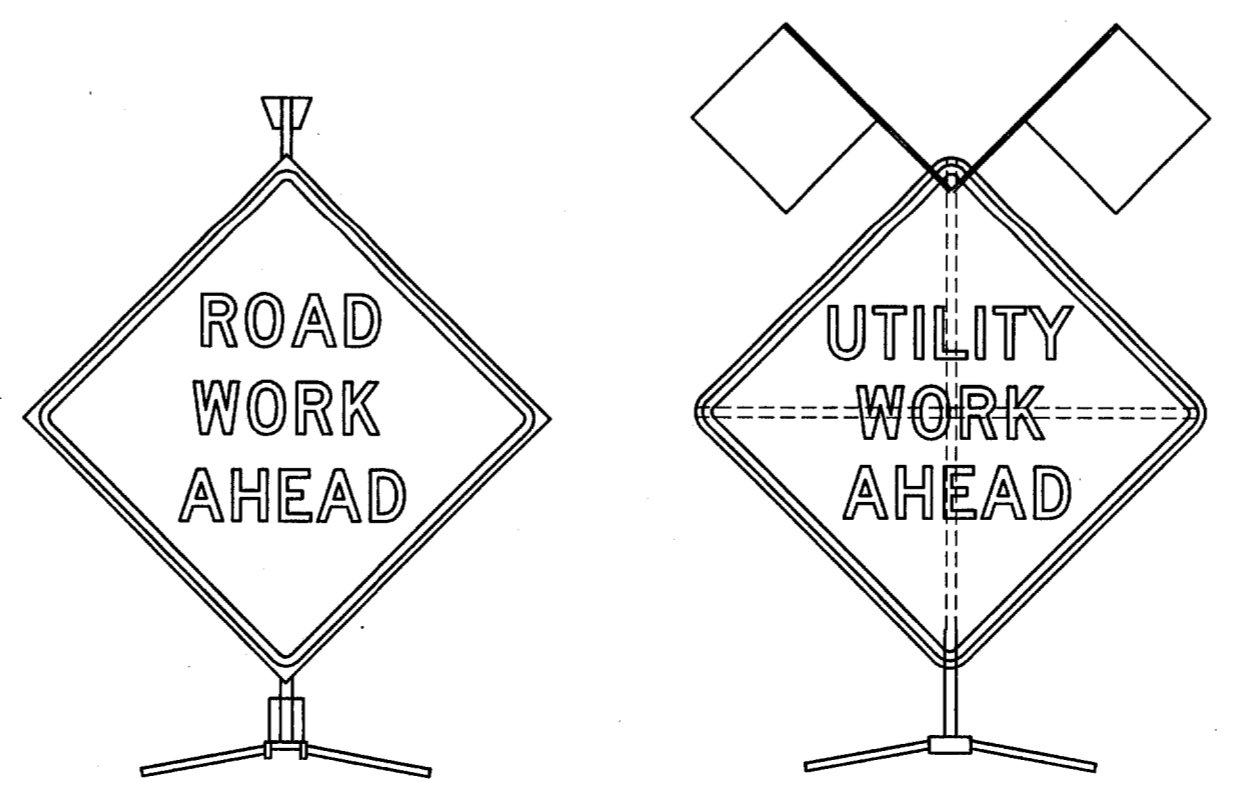

GENERAL

All sign usage and erection shall be in strict accordance with the "Texas Manual on Uniform Traffic Control Devices for Streets and Highways" (TMUTCD). The Contractor shall maintain each sign as directed by the Owner. The Contractor shall use the sign designs shown in the "Standard Highway Sign Designs for Texas" (SHSD). All work zone signs provided for in the TMUTCD but not detailed in the plans may be used when directed by the Owner.

WARNING LIGHTS

When required by the Owner the Contractor shall furnish a copy of the warning light certification. The certification will be by the manufacturer, stating the lights meet the requirements of the latest ITE Purchase Specification for Flashing and Steady-Burn Warning Lights.

REFLECTIVE SHEETING

Type A, B or C sheeting may be used for all, day only, applications. Type A sheeting should be used for all, white background, regulatory signs. Type C sheeting shall be used for all other applications. The above applications of sheeting grades to different type signs will apply unless otherwise specified in the plans. TYPE A - Engineer Grade TYPE B - Super Engineer Grade TYPE C - High Specific Intensity

SUPPORTS AND MOUNTING HEIGHT

Regardless of the type of support used, or duration of work, regulatory signs should not be erected at heights less than 7 feet above the pavement surface.

Wood sign post supports shall be painted white. Signs may be erected on portable or fixed supports for use on construction projects to warn or guide traffic through and/or around the actual construction area.

PORTABLE - Signs erected on portable supports for use on construction projects normally mean signs which are used during the daytime to warn or guide traffic through and/or around the actual construction area, but at the end of the workday such signs are removed.

Portable supports shall be as shown on this sheet. Signs with portable supports may be used for short term, short duration and mobile operations. The bottom of the sign shall be a minimum of one (1) foot above the pavement surface.

FIXED - Signs erected on fixed supports for use on construction projects normally mean signs that are to remain in place for both daytime and nighttime usage to regulate, warn and guide traffic in advance of and within the limits of the project including the crossroad approaches. Signs erected on fixed supports should be at a minimum height of seven (7) feet.

SIGN SUPPORT WEIGHTS

Where sign supports require the use of weights to keep from turning over, the use of some type of sandbag is recommended. The use of pieces of rock, concrete, iron, steel or other solid objects will not be permitted. Sandbags shall only be placed along or upon the base supports of the device and shall not be suspended above ground level or hung with rope, wire, chains or other fasteners.

REMOVING OR COVERING

When sign messages may be confusing or no longer apply, the signs and supports shall be removed from roadway and shoulder, or the signs shall be completely covered. Turning signs from motorists view will not be allowed. When signs are covered the material used shall be opaque, such as heavy mil black plastic. Burlap shall not be used to cover signs. Signs shall be removed upon completion of the work. Duct tape or other adhesive material shall not be affixed to sign face.

DATE	REVISION	BY
TOWN OF ADDISON DALLAS COUNTY, TEXAS		
DETAIL SHEET TRAFFIC CONTROL PLAN		
SHEET 2 OF 2 PROJECT No.		
 2630 W. FREEWAY #132 • FORT WORTH, TEXAS 76102 • (817) 877-5803		
DESIGNED :	S.C.B.	FILE : WZ-2
APPROVED :	R.W.J.	CHECKED : A.M. SHEET 20 OF 20

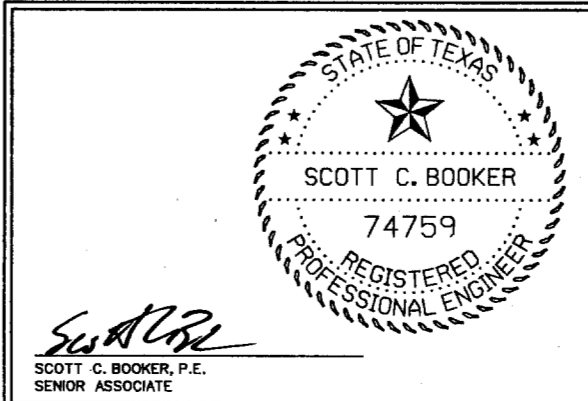

8-21-98