

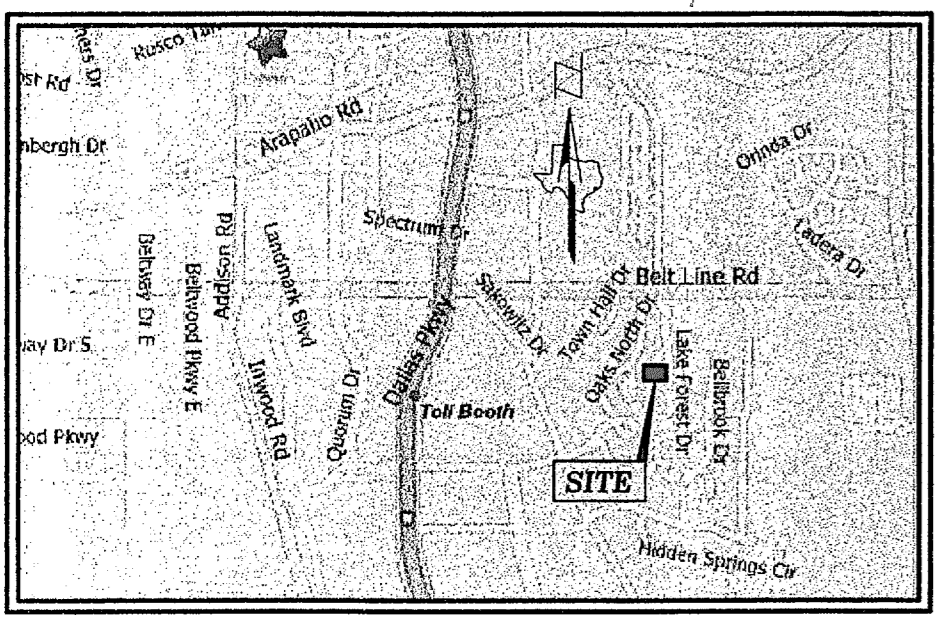

**LOT 1B, MILLIKEN ADDITION**  
 VICTOR MEYER CUSTOM HOMES, LLC  
 MICHAEL AND RACHEL HARDIN  
**14905 LAKE FOREST DRIVE**  
**ADDISON, TEXAS**

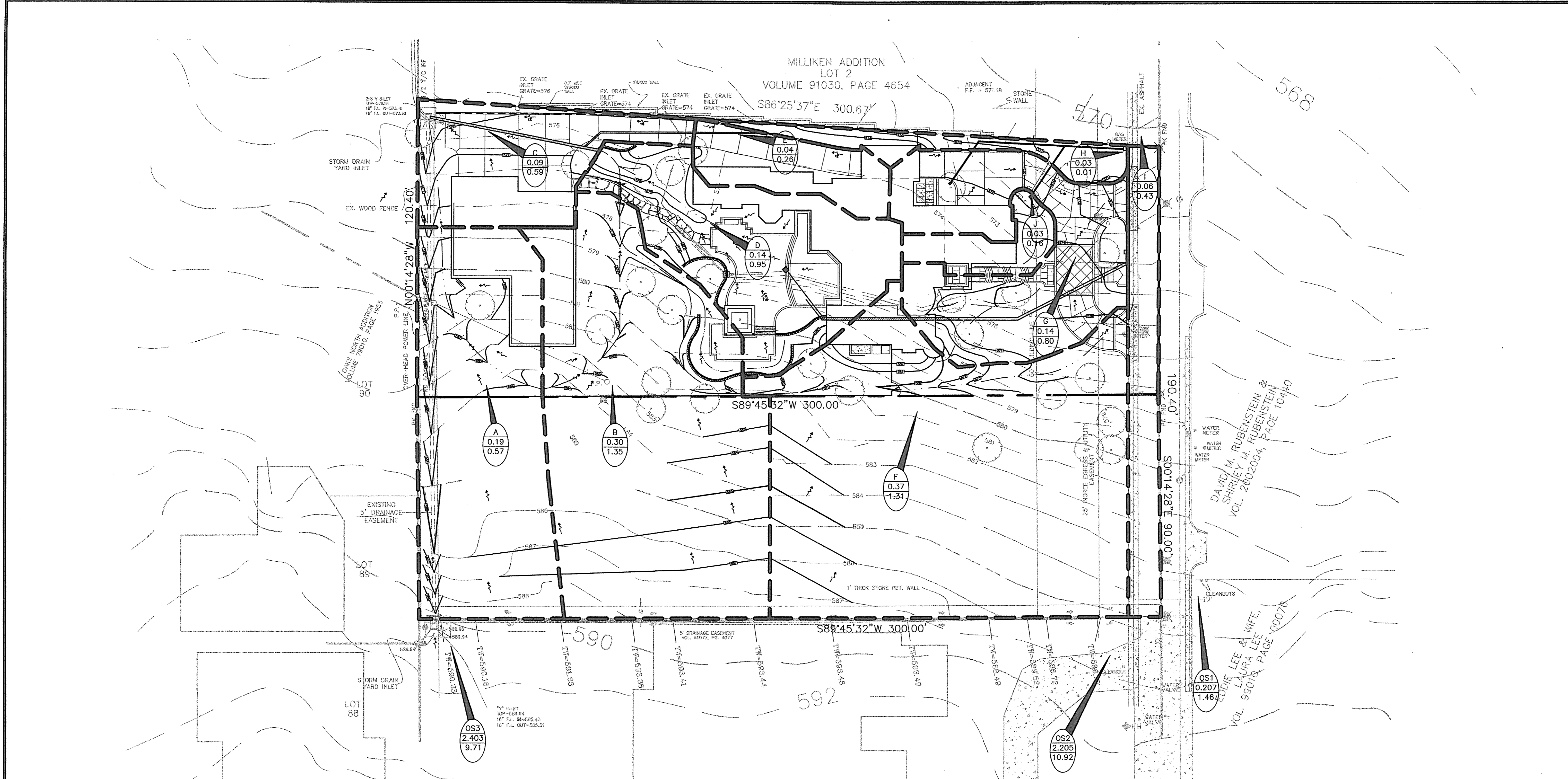

**VICINITY MAP**

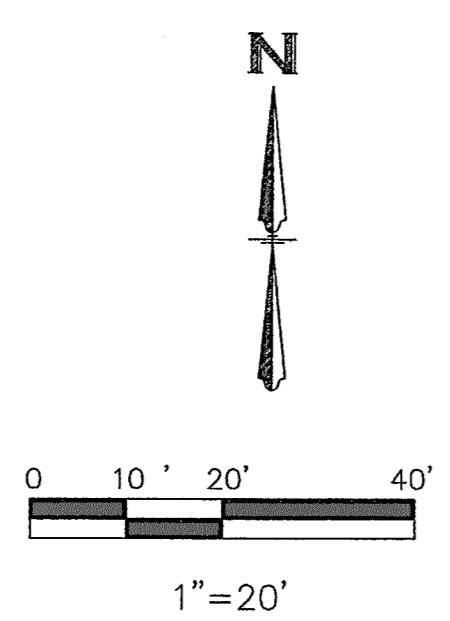

**BENCH MARKS**

**BENCHMARK:**  
 SQUARE CUT ON CURB RETURN WEST SIDE OF MONFORT  
 AND SAKOWITZ, NE CORNER  
 ELEV=608.63



TEXAS EXCAVATION  
 SAFETY SERVICES  
 1-800-344-8377

POST DEVELOPED DRAINAGE SUMMARY										
100 YEAR STORM EVENT										
LAKE FOREST DRIVE - ADDISON TEXAS										
DRAINAGE AREA	IMPERVIOUS AREA	PERVIOUS AREA	TOTAL AREA	C IMPERVIOUS	C PERVIOUS	WEIGHTED C VALUE	Tc	I(100) (IN/HR)	Q (100) (cfs)	REMARKS
	C=0.95	C=0.25	(ac)							
<b>TOWARDS NW PROPERTY CORNER</b>										
A	0.040	0.150	0.190	0.95	0.25	0.40	15	7.52	0.57	DRAINS TOWARDS NW PROP CORNER
B	0.150	0.150	0.300	0.95	0.25	0.60	15	7.52	1.35	DRAINS TOWARDS NW PROP CORNER
C	0.080	0.010	0.090	0.95	0.25	0.87	15	7.52	0.59	DRAINS TOWARDS NW PROP CORNER
D	0.130	0.010	0.140	0.95	0.25	0.90	15	7.52	0.95	DRAINS TOWARDS NW PROP CORNER
E	0.036	0.004	0.040	0.95	0.25	0.88	15	7.52	0.26	DRAINS TOWARDS NW PROP CORNER
<b>TOTAL</b>			<b>0.760</b>						<b>3.724</b>	
<b>TOWARDS LAKE FOREST</b>										
F	0.175	0.175	0.350	0.95	0.25	0.50	15	7.52	1.31	TOWARDS SWALE IN LAKE FOREST DR.
G	0.112	0.028	0.140	0.95	0.25	0.76	15	7.52	0.80	TOWARDS SWALE IN LAKE FOREST DR.
H	0.000	0.030	0.030	0.95	0.25	0.06	15	7.52	0.01	TOWARDS SWALE IN LAKE FOREST DR.
I	0.060	0.000	0.060	0.95	0.25	0.95	15	7.52	0.43	TOWARDS SWALE IN LAKE FOREST DR.
J	0.023	0.007	0.030	0.95	0.25	0.73	15	7.52	0.16	TOWARDS SWALE IN LAKE FOREST DR.
<b>TOTAL</b>			<b>0.610</b>						<b>2.713</b>	

Revisions:

#	Date Issued:	Description:

Sheet Title:  
**POST DEVELOPED DRAINAGE AREA MAP**  
 Date: August 7, 2009  
 Project Number: 09015.0  
 Drawn By: TJB