

HOOKED ANCHOR (TYPE 1) NUT ANCHOR (TYPE 2)

ANCHOR BOLT ASSEMBLY

ANCHOR BOLT & TEMPLATE SIZES						
BOLT DIAMETER	BOLT LENGTH	TOP THREAD	BOTTOM THREAD	BOLT CIRCLE	R2	R1
3/4"	1'-6"	3"	-	12-3/4"	7-1/8"	5-5/8"
1-1/2"	3'-4"	6"	2"	17"	10"	7"
1-3/4"	3'-10"	7"	2-1/4"	19"	11-1/8"	7-3/4"
2"	4'-3"	8"	2-1/2"	21"	12-1/2"	8-1/2"

* MINIMUM DIMENSIONS GIVEN, LONGER BOLTS ARE ACCEPTABLE.

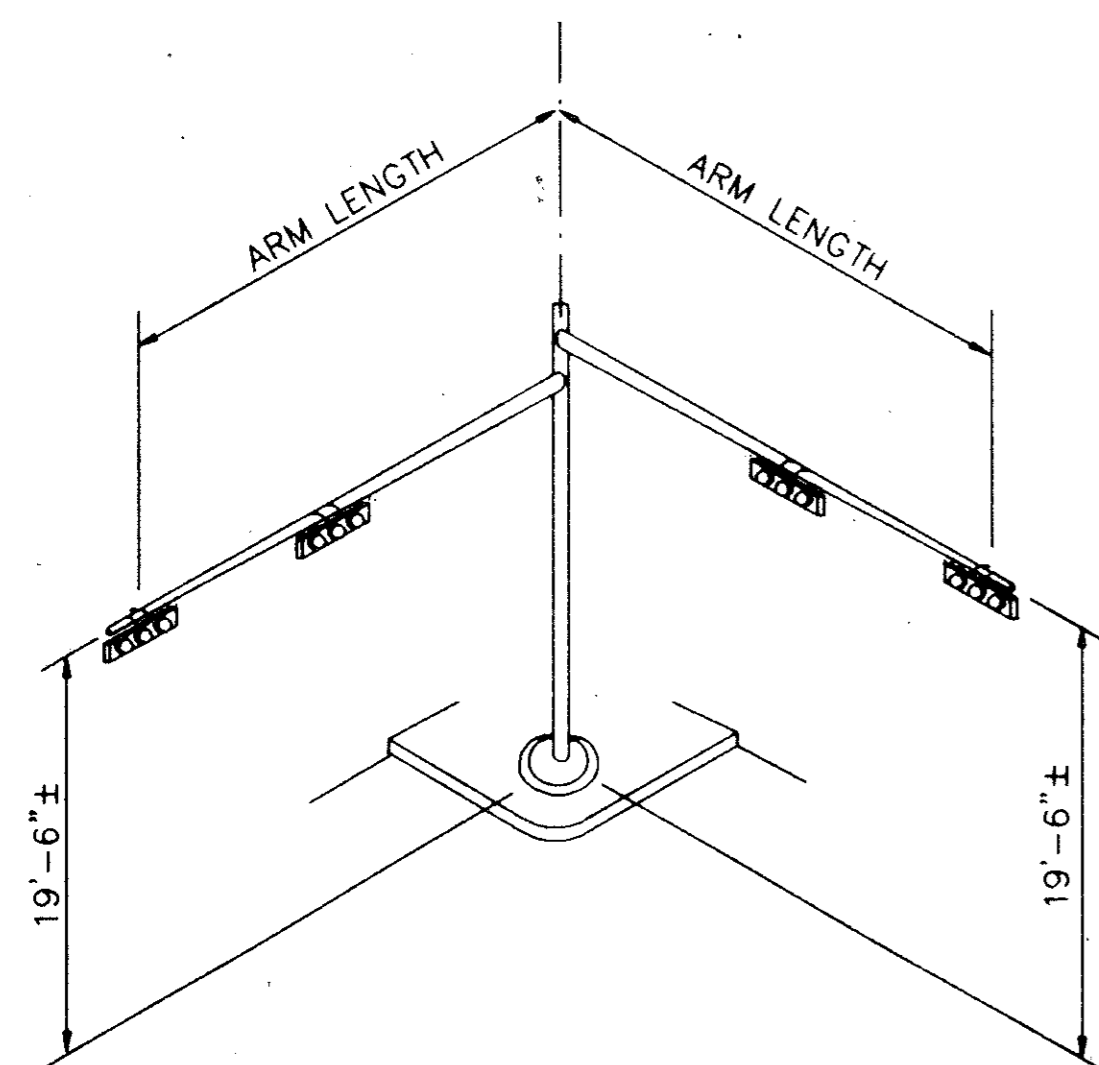

TYPICAL MAST ARM ASSEMBLY

INSTALLATION PROCEDURE :

THREADS OF ANCHOR BOLTS SHALL BE COATED WITH PIPE JOINT COMPOUND PRIOR TO INSTALLATION OF UPPER NUTS WHEN ERECTING POLE. AFTER POLE IS PLUMBED AND IN PERMANENT ALIGNMENT, THE EXPOSED THREADS OF PAINTED BOLTS SHALL BE CLEANED AND AN ADDITIONAL COATING OF ZINC-RICH PAINT APPLIED TO SEAL THE BOLT THREAD-NUT JOINT.

NOTES :

- (1) ANCHOR BOLT DESIGN DEVELOPS THE FOUNDATION CAPACITY GIVEN UNDER FOUNDATION DESIGN LOADS.
- (2) FOUNDATION DESIGN LOADS ARE THE ALLOWABLE MOMENTS AND SHEARS AT THE BASE OF THE STRUCTURE.
- (3) FOUNDATIONS MAY BE LISTED SEPARATELY OR GROUPED ACCORDING TO SIMILARITY OF LOCATION AND TYPE. QUANTITIES ARE FOR THE CONTRACTOR'S INFORMATION ONLY.
- (4) FIELD PENETROMETER READINGS AT A DEPTH OF APPROXIMATELY 3 TO 5 FEET MAY BE USED TO ADJUST SHAFT LENGTHS.
- (5) IF ROCK IS ENCOUNTERED, THE DRILLED SHAFT SHALL EXTEND A MINIMUM OF TWO DIAMETERS INTO SOLID ROCK.
- (6) DECIMAL LENGTHS IN DESIGN TABLE ARE TO ALLOW INTERPOLATION FOR OTHER PENETROMETER VALUES. ROUND TO NEAREST FOOT FOR ENTRY INTO SUMMARY TABLE.

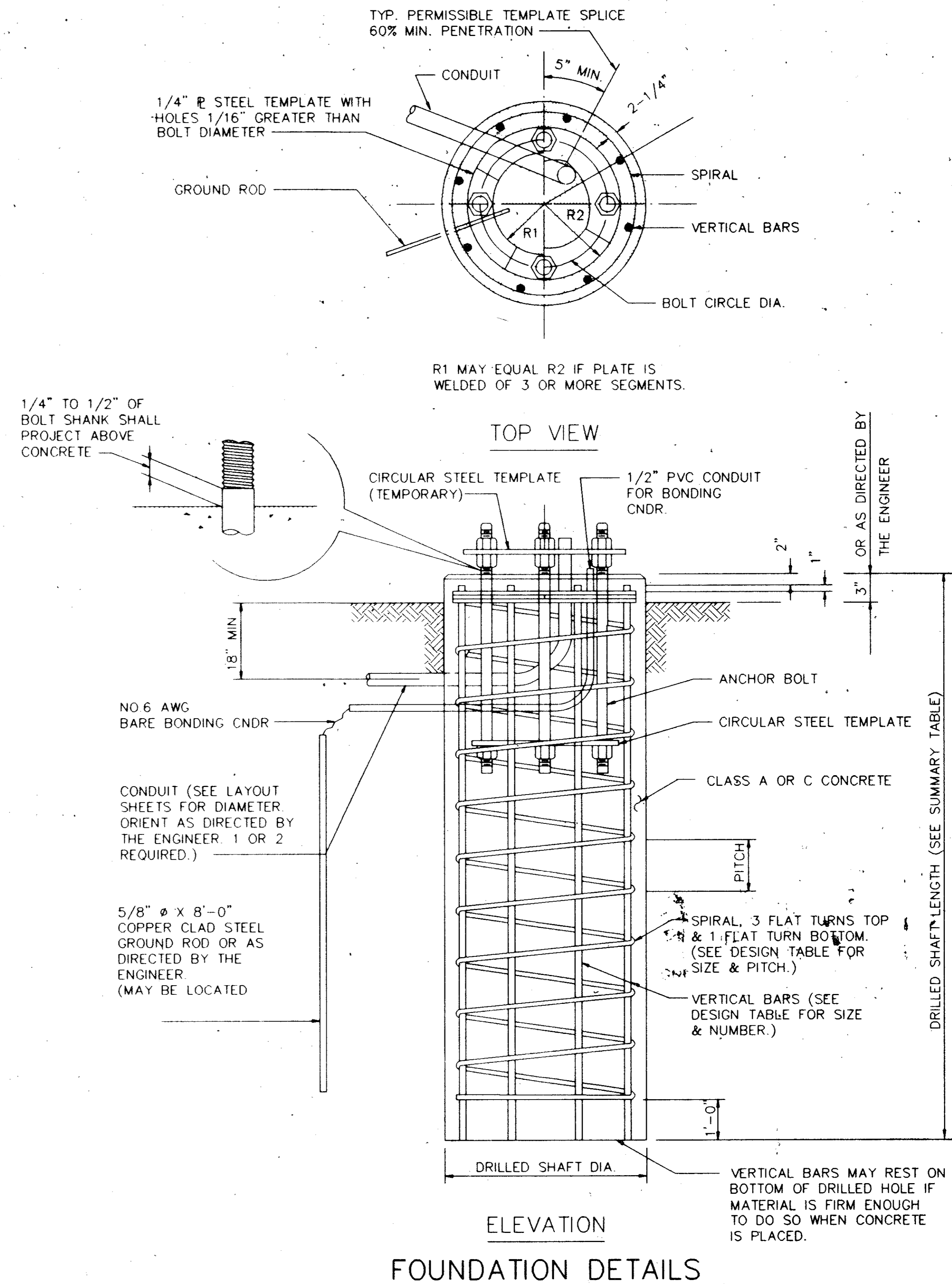

App. _____

Revisions _____

No. _____ Date _____

Barton-Aschman Associates, Inc.

TRAFFIC SIGNAL POLE FOUNDATIONS

Date: 6/6/95

Scale: V - _____

Designed by: _____

Drawn by: _____

Checked by: TJS

Approved by: TJS

Project No. 664003.01000

SHEET 5

OF 9