

SPRING VALLEY ROAD at BROOKHAVEN CLUB DRIVE

3 Phase Fully Actuated Controller W/3M-OPTICOM Fire Preempt System integrated within Controller. (Fire Pre-emption from All 3 Directions)

INTERVAL A - BROOKHAVEN CLUB DRIVE
INTERVAL B - SPRING VALLEY ROAD

SIGNAL HEAD DISPLAYS/INTERVAL CHART

INTERVAL	SIGNAL HEAD No.											
	1	2	3	4	5	6	7	8	9	10	11	12
A	←R-	←R-	←R-	←G-	←G-	R	R	DW	DW			
A CLEAR RED	←R-	←R-	←R-	←Y-	←Y-	R	R	DW	DW			
ALL RED	←R-	←R-	←R-	←R-	←R-	R	R	DW	DW			
B1	←R-	←R-	←R-	←R-	←R-	G	G	WALK	WALK			
B1 PED CLEAR	←R-	←R-	←R-	←R-	←R-	G	G	FLASH WALK	FLASH WALK			
B1 CLEAR RED	←R-	←R-	←R-	←R-	←R-	Y	Y	DW	DW			
ALL RED	←R-	←R-	←R-	←R-	←R-	R	R	DW	DW			
B2	←G-	←G-	←G-	←R-	←R-	R	R	DW	DW			
B2 CLEAR RED	←Y-	←Y-	←Y-	←R-	←R-	R	R	DW	DW			
ALL RED	←R-	←R-	←R-	←R-	←R-	R	R	DW	DW			

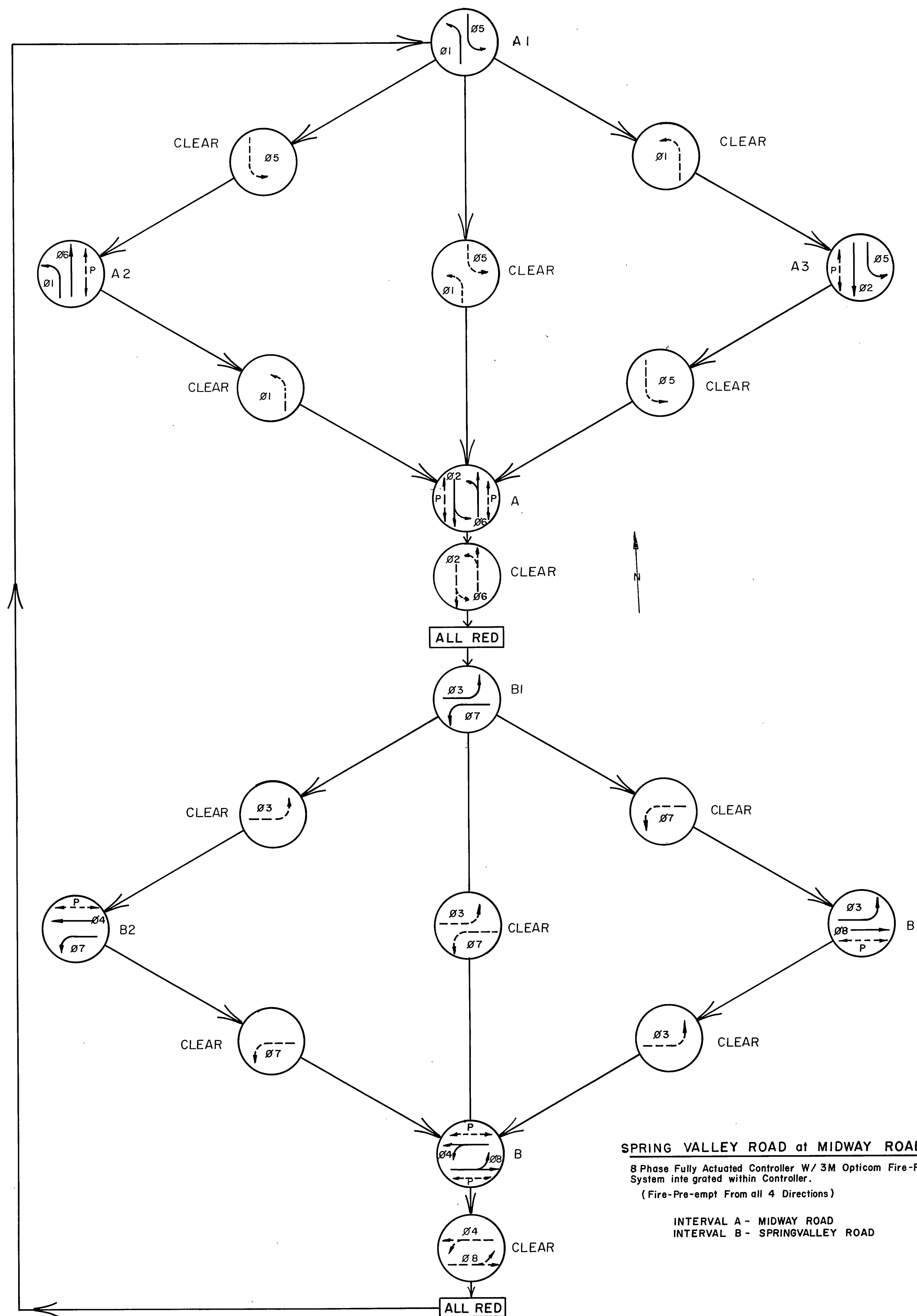

SPRING VALLEY ROAD at MIDWAY ROAD

8 Phase Fully Actuated Controller W/ 3M Opticom Fire-Preempt System into graded within Controller. (Fire-Pre-empt From all 4 Directions)

INTERVAL A - MIDWAY ROAD
INTERVAL B - SPRING VALLEY ROAD

SIGNAL HEAD DISPLAYS/INTERVAL CHART

INTERVAL	SIGNAL HEAD No.												
	1,2	3	10,11	12	4,5	6	7,8	9	13,15	17,19	14,18	16,20	
A1	R	R	←G	R	←G	R	R	R	R	DW	DW	DW	
A1 CLEAR A2	R	R	←Y	R	←Y	R	R	R	R	DW	DW	DW	
A1 CLEAR A3	R	R	←G	R	←G	R	R	R	R	DW	DW	DW	
A1 CLEAR A	R	R	←Y	R	←Y	R	R	R	R	DW	DW	DW	
A2	R	R	G	G	←G	R	R	R	R	DW	WALK	DW	
A2 PED CLEAR	R	R	G	G	←G	R	R	R	R	DW	FLASH WALK	DW	
A2 CLEAR A	R	R	G	G	←Y	R	R	R	R	DW	WALK	DW	
A3	G	G	←G	R	R	R	R	R	R	WALK	DW	DW	
A3 PED CLEAR	G	G	←G	R	R	R	R	R	R	FLASH WALK	DW	DW	
A3 CLEAR A	G	G	←Y	R	R	R	R	R	R	WALK	DW	DW	
A	G	G	G	G	R	R	R	R	R	WALK	WALK	DW	
A PED CLEAR	G	G	G	G	R	R	R	R	R	FLASH WALK	FLASH WALK	DW	
A CLEAR	Y	Y	Y	Y	R	R	R	R	R	DW	DW	DW	
ALL RED	R	R	R	R	R	R	R	R	R	DW	DW	DW	
B1	R	R	R	R	R	R	←G	R	←G	R	DW	DW	
B1 CLEAR B2	R	R	R	R	R	R	←Y	R	←Y	R	DW	DW	
B1 CLEAR B3	R	R	R	R	R	R	←G	R	←G	R	DW	DW	
B1 CLEAR B	R	R	R	R	R	R	←Y	R	←Y	R	DW	DW	
B2	R	R	R	R	G	G	←G	R	R	DW	DW	DW	
B2 PED CLEAR	R	R	R	R	G	G	←G	R	R	DW	DW	DW	
B2 CLEAR B	R	R	R	R	G	G	←Y	R	R	DW	DW	DW	
B3	R	R	R	R	R	R	G	G	←G	DW	DW	WALK	
B3 PED CLEAR	R	R	R	R	R	R	G	G	←G	DW	DW	FLASH WALK	
B3 CLEAR B	R	R	R	R	R	R	G	G	←Y	DW	DW	WALK	
B	R	R	R	R	G	G	G	G	G	DW	DW	WALK	
B PED CLEAR	R	R	R	R	G	G	G	G	G	DW	DW	FLASH WALK	
B CLEAR	R	R	R	R	Y	Y	Y	Y	Y	DW	DW	DW	
ALL RED	R	R	R	R	R	R	R	R	R	DW	DW	DW	

Hal B Jones

UNDER CONTRACT BY
H.B. JONES
Consulting Engineers Garland, Texas

No.	Revision	By	Date
CITIES OF ADDISON & FARMERS BRANCH DALLAS COUNTY, TEXAS			
TRAFFIC SIGNAL INSTALLATION			
INTERVAL & PHASING DIAGRAMS			
GINN, INC. Consulting Engineers Dallas, Texas			
DESIGN HBJ	DRAWN R.G.B.	SCALE 1"=20'	PROJ.
APPROVED H.B.J.	CHK'D H.B.J.	DATE SEPT 1983	SHEET 9 of 14