

GENERAL NOTES

FOR TYPE III BARRICADES

Type III Barricades are to be used at each end of construction projects closed to all traffic. Barricades extending across a roadway should have stripes that slope downward in the direction toward which traffic must turn in detouring. When both right and left turns are provided for, the chevron striping may slope downward in both directions from the center of the barricade. Striping of rails, for the right side of the roadway, should slope downward to the left. For the left side of the roadway, striping should slope to the right. Identification markings may be shown only on back side of barricade rails. Maximum height of letters shall be 1 inch. Barricades shall not be placed parallel to traffic unless an adequate clear zone is provided (see BC(1)).

Barricades shall be made using pre-qualified materials. A list of compliant products and their sources may be obtained by writing or faxing:

Standards Engineer
Traffic Operations Division - TE
Texas Department of Transportation
125 East 11th Street
Austin, Texas 78701-2483
Phone (512) 416-3120
Fax (512) 416-3161
E-mail TRF-STANDARD@mailgw.dot.state.tx.us

Barricades shall NOT be used as a sign support.

TYPICAL STRIPING DETAIL FOR BARRICADE RAIL

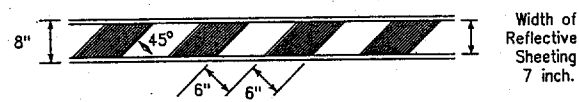

TYPICAL PANEL DETAIL FOR SKID OR POST TYPE BARRICADES

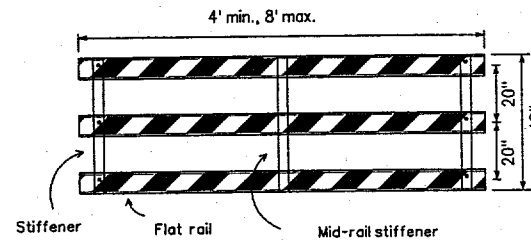

Stiffener may be inside or outside of support.

* For dimensions of components refer to TxDOT approved products list.

WOOD/PLASTIC TYPE III BARRICADE OPTION

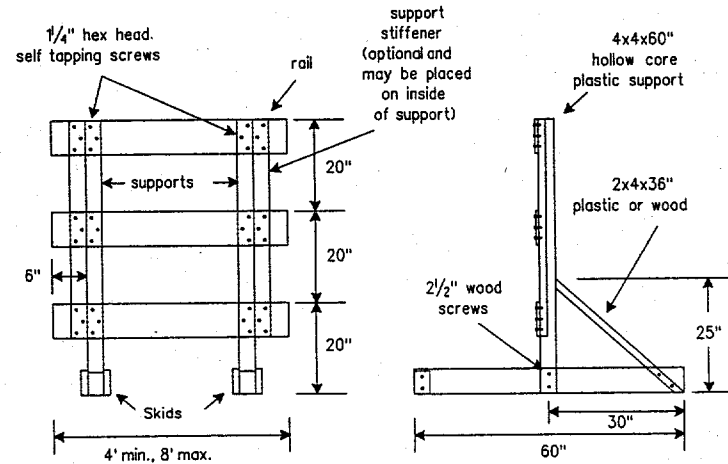

WOOD/PLASTIC/FIBERGLASS TYPE III BARRICADE OPTION

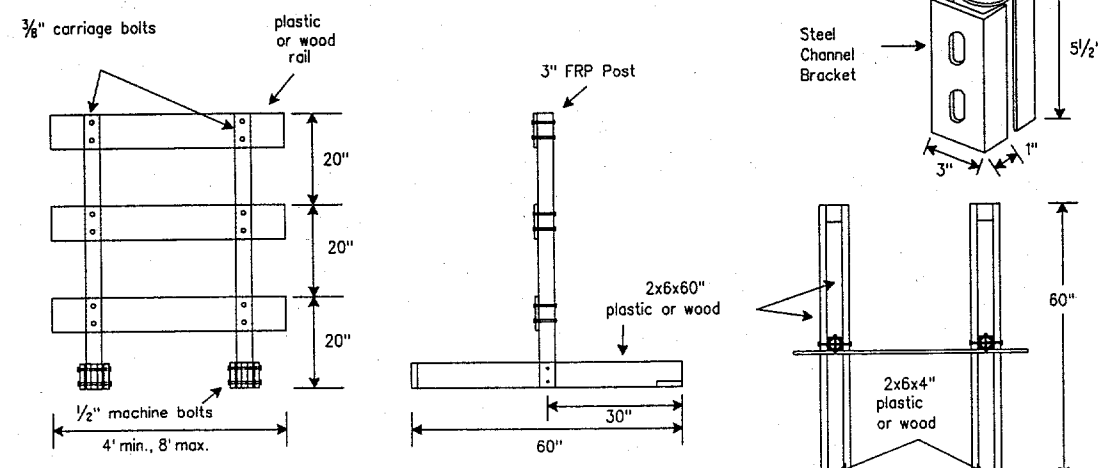

TYPE III BARRICADE (SKID)

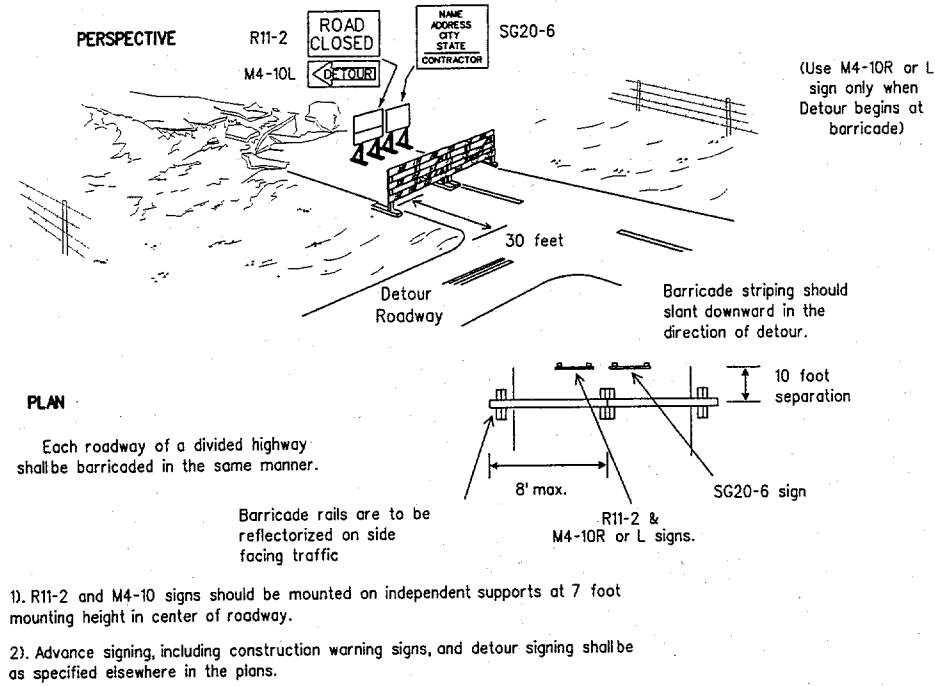

PERFORATED STEEL/WOOD/PLASTIC TYPE III BARRICADE OPTION

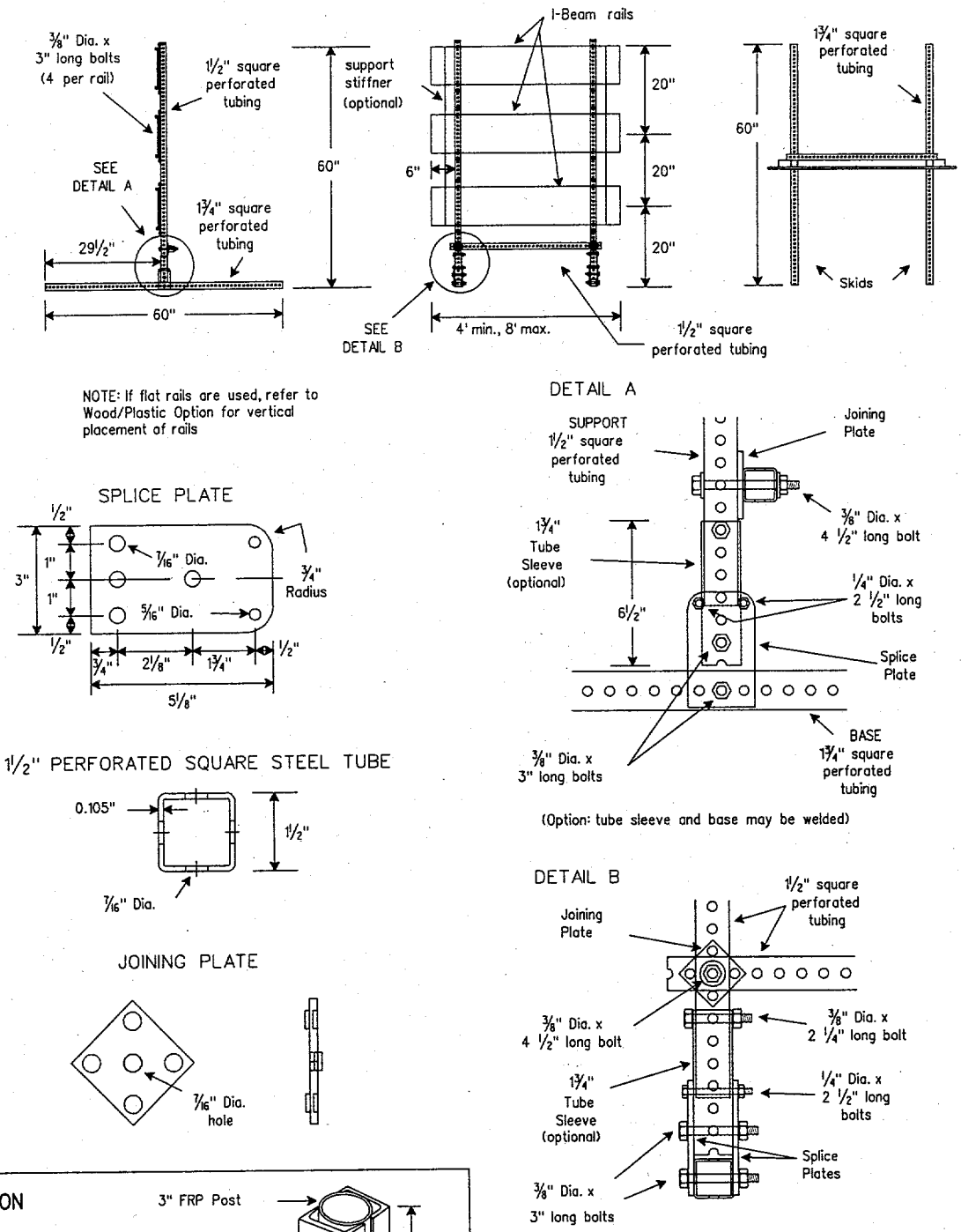

DISCLAIMER: The use of this standard is governed by the "Texas Engineering Practice Act". No warranty of any kind is made by TxDOT for any purpose whatsoever. TxDOT assumes no responsibility for the conversion of this standard to other formats or for incorrect results or damages resulting from its use.

DATE:	1	2	3	4	5	6	7	8	9	10	11	12	13	14	15	16	17	18	19	20	21	22	23	24	25	26	27	28	29	30	31	
LEVELS DISPLAYED:																																
FILE:																																

STANDARD PLANS
TEXAS DEPARTMENT OF TRANSPORTATION
Traffic Operations Division

BARRICADE AND CONSTRUCTION STANDARDS

BARRICADES (SKID MOUNT TYPE) **BC(2)-98**

© TxDOT February 1998

REVISED	DATE	BY	REASON	FEDERAL PROJECT	SHEET
1	6	LR	DTN	DN	GB
					25
COUNTY	CONTROL	SECTION	JOB	HIGHWAY	