

1 SECTION
SCALE: 3/4" = 1'-0" TYPICAL U.N.O.

2 SECTION

3 SECTION

4 SECTION

TOWN OF ADDISON
SUBJECT'S COPY OF PLANS
This set of plans contains various corrections and comments made by the City Staff. All trades will be required to comply with these corrections and comments. Failure to do so in all respects of this information will not be accepted as a to approve construction which is in violation of local ordinances.
This set of plans is to be kept on the job site at all times and is to be made available for use by city inspectors at their request. Failure to have these plans available may delay approval of a requested inspection.

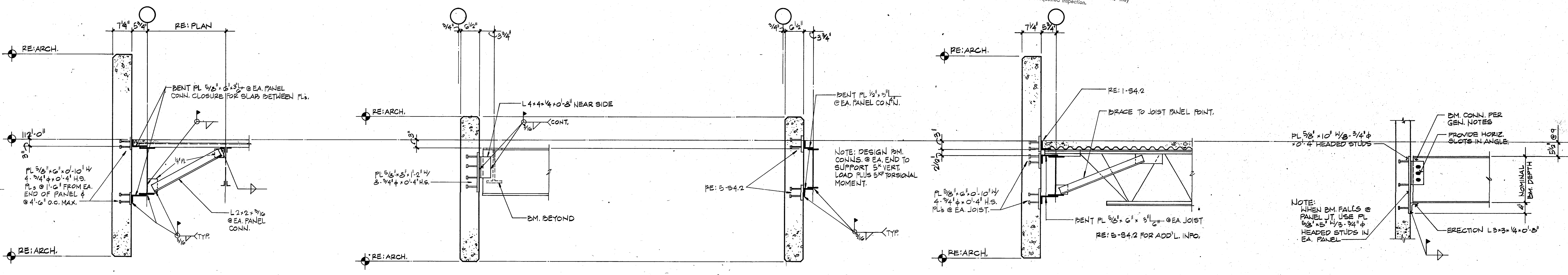

5 SECTION

6 SECTION

7 SECTION

8 SECTION

9 9A SECTION

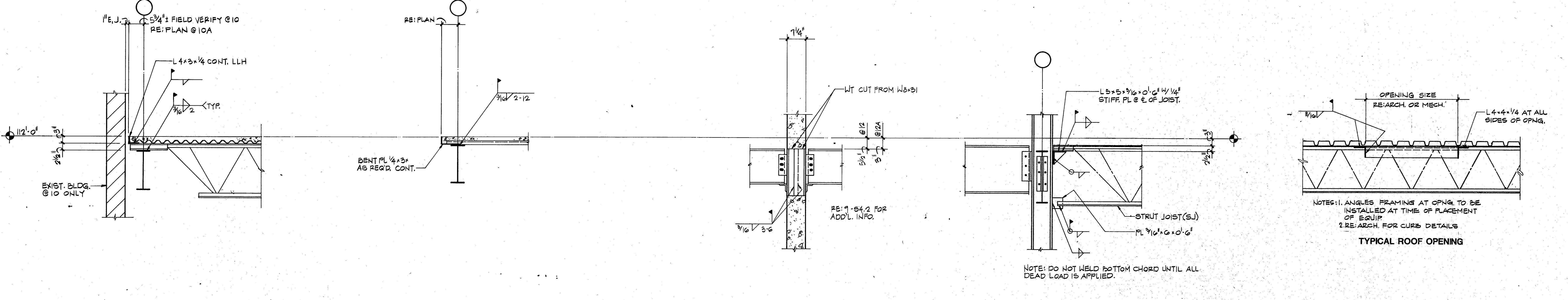

10 10A SECTION

11 SECTION

12 SECTION

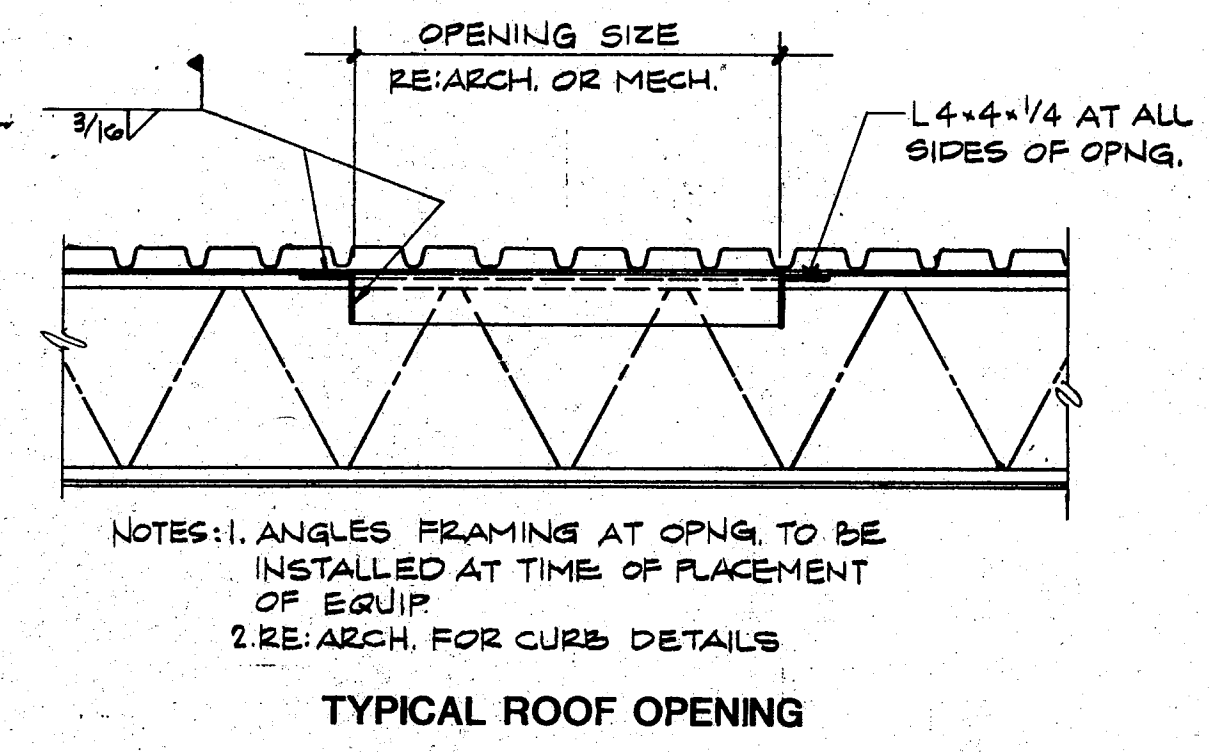

TYPICAL ROOF OPENING

TYPICAL STEEL CONNECTIONS AT COLUMN

PRELIMINARY DRAWING
NOT TO BE USED FOR CONSTRUCTION

INTERFIELD ENGINEERING CO.
CONSULTING ENGINEERS
5401 N. CENTRAL EXPWY.
SUITE 340
DALLAS, TEXAS 75205
(214) 626-8854

ED I ARCHITECTS, INC.
ARCHITECTURE PLANNING ENGINEERING INTERIOR DESIGN
8440 WALNUT HILL LANE
SUITE 100
DALLAS, TEXAS 75201
817 / 458-8300

TOWN OF
Addison

ADDITION TO
PUBLIC WORKS SERVICE CENTER
Addison Texas
Westgrove Road

DATE:
11 JUNE 86
24 JULY 1986 - BID

SHEET NO:
S4.2
OF SHEETS
JOB NO: 851-137