

SECTION 02810 - IRRIGATION

PART 1 - GENERAL

- 1.1 SCOPE**
- A. Provide complete sprinkler installation as detailed and specified herein, includes furnishing all labor, materials, and equipment for the proper installation. Work includes but is not limited to:
 1. Trenching and backfill
 2. Automatic controlled system.
 3. Upon completion of installation, supply drawings showing details of construction including location of mainline piping, manual and automatic valves, electrical supply to valves, and specifically exact location of automatic valves.
 - B. All sleeves as shown on plans will be furnished by General Contractor. Meter and power source to be provided by General Contractor.
- 1.2 RELATED WORK SPECIFIED ELSEWHERE**
- A. See Irrigation Plans. See plans for controller, heads, and valves.
 - B. Section 02900-Landscape
 - C. Section 02811-Underground Irrigation Sleeve and Utility Conduits
- 1.3 APPLICABLE STANDARDS**
- A. America Standard for Testing and Materials (ASTM) - Latest edition.
 1. D2241 Poly (Vinyl Chloride) (PVC) Plastic Pipe (SDR-PR)
 2. D2464 Poly (Vinyl Chloride) (PVC) Plastic Pipe Fittings, Thread, Schedule 80
 3. D2465 Poly (Vinyl Chloride) (PVC) Plastic Pipe Fittings, Schedule 40
 4. D2467 Poly (Vinyl Chloride) (PVC) Plastic Pipe Fittings, Socket Type, Schedule 80
 5. D2564 Solvent Cements for Poly (Vinyl Chloride) (PVC) Plastic Pipe and Fittings
 6. D2287 Flexible Poly Vinyl Chloride (PVC) Plastic Pipe
 7. F556 Poly Vinyl Chloride (PVC) Solvent Weld Primer
 8. D2855 Mating Solvent - Cemented Joints with Poly (Vinyl Chloride) (PVC) Pipe and Fittings
- 1.4 MAINTENANCE AND GUARANTEE**
- A. Materials and workmanship shall be fully guaranteed for one (1) year after final acceptance.
 - B. Provide maintenance of system, including raising and lowering of heads to compensate for lawn growth, cleaning and adjustment of heads, raising and lowering of shrub heads to compensate for shrub growth, for one (1) year after completion of installation.
 - C. Guarantee is limited to repair and replacement of defective materials or workmanship, including repair of backfill settlement.

1.5 SUBMITTALS

- A. Procedure: Comply with Division I requirements.
- B. Product Data: Submit (5) copies of equipment manufacturer's specifications and literature for approval by Landscape Architect prior to installation.
- C. Project Record Documents
 1. Comply with Division I requirements.
 2. Locate by written dimension, routing of mainline piping, remote control valves and quick coupling valves. Locate mainlines by single dimensions from permanent site features provided they run parallel to these elements. Locate valves, intermediate electrical connections, and quick couplers by two dimensions from a permanent site feature at approximately 70 degrees to each other.
 3. When dimensioning is complete, transcribe work to mylar reproducible tracings.
 4. Submit completed tracings prior to final acceptance. Mark tracings "Record Prints Showing Significant Changes". Date and sign drawings.
 5. Provide three complete operation manuals and equipment brochures neatly bound in a hard back three-ring binder. Include product data on all installed materials. Include warranties and guarantees extended to the Owner by the manufacturer of all equipment.
- D. Quick Coupler Keys: Provide 3 coupler keys with boiler drains attached using brass reducer.
- E. Controller Keys: Provide three sets of keys to controller enclosure(s).
- F. Use of materials differing in quality, size, or performance from those specified will only be allowed upon written approval of the Landscape Architect. The decision will be based on comparative ability of material or article to perform fully all purposes of mechanics and general design considered to be possessed by item specified.
- G. Bidders desiring to make a substitution for specified sprinklers shall submit manufacturer's catalog sheet showing full specification of each type sprinkler proposed as a substitute, including discharge in GPM maximum allowable operating pressure at sprinkler.
- H. Approval of substitute sprinkler shall not relieve Irrigation Contractor of his responsibility to demonstrate that final installed sprinkler system will operate according to intent of originally designed and specified system.
- I. It is the responsibility of the Irrigation Contractor to demonstrate that final installed sprinkler system will operate according to intent of originally designed and specified system. If Irrigation Contractor notes any problems in head spacing or potential coverage, it is his responsibility to notify the Landscape Architect in writing, before proceeding with work. Irrigation Contractor guarantees 100% coverage of all areas to be irrigated.

1.6 TESTING

- A. Perform testing required with other trades, including earthwork, paving, plumbing, electrical, etc to avoid unnecessary cutting, patching and boring.
- B. Wire Connectors: Waterproof splice kit connectors. Type DBY by 3M.

2.6 SCHEDULE 80 PVC NIPPLES

- A. Composed of Standard Schedule 40 PVC Fittings and PVC meeting noted standards. No clamps or wires may be used. Nipples for heads and shrub risers to be nominal one-half inch diameter by eight inches long, where applicable.
- B. Polyethylene nipples six (6") inches long to be used on all pop-up spray heads.

2.7 MATERIALS - See Irrigation Plan

- A. Sprinkler heads in lawn area as specified on plan.
- B. PVC Pipe: Class 200, SPR 21 Copper Tubing (City Connection). Type "M" 24V Wire. Size 14, Type U.F.
- C. Electric valves to be all plastic construction as indicated on plans.
- D. Refer to drawing for backflow prevention requirements and flow valve.

PART 3 - EXECUTION

3.1 INSTALLATION - GENERAL

- A. Staking: Before installation is started, place a stake where each sprinkler is to be located, in accordance with drawing. Staking shall be approved by Landscape Architect before proceeding.
- B. Excavations: Excavations are unclassified and include earth, loose rock, rock or any combination thereof, in wet or dry state. Backfill trenches with material that is suitable for compaction and contains no lumps, clods rock, debris, etc. Special backfill specifications, if furnished take preference over this general specification.
- C. Backfill: Flood or hand-tamp to prevent after setting. Hand rake trenches and adjoining area to leave grade in as good or better condition than before installation.
- D. Piping Layout: Piping layout is diagrammatic. Route piping around trees and shrubs in such a manner as to avoid damage to plantings. Do not dig within ball of newly planted trees or shrubs.

3.2 PIPE INSTALLATION

- A. Sprinkler Mains: Install a four (4") inch minimum trench with a minimum of eighteen (18") inches of cover.
- B. Lateral Piping: Install a four (4") inch wide minimum trench deep enough to allow for installation of sprinkler heads and valves, but in no case, with less than twelve (12") of cover.
- C. Trenching: Remove lumber, rubbish, and large rocks from trenches. Provide firm, uniform bearing for entire length of each pipe line to prevent uneven settlement. Wedging or blocking of pipe will not be permitted. Remove foreign matter or dirt from inside of pipe before welding, and keep piping clean by approved means during and after laying of pipe.

3.3 PVC PIPE AND FITTING ASSEMBLY

- A. Solvent: Use only solvent recommended by manufacturer to make solvent-welded joints. Thoroughly clean pipe and fittings of dirt, dust and moisture before applying solvent.
- B. PVC to metal connection: Work metal connections first. Use a non-hardening pipe dope such as Permatex No. 2 on threaded PVC adapters into which pipe may be welded.

3.4 COPPER TUBING AND FITTING ASSEMBLY

- Clean pipe and fitting thoroughly and lightly sand pipe connections to remove residue from pipe. Attach fittings to tubing in an approved manner using 50-50 soft solid core solder.

3.5 POP-UP SPRAY HEADS

- Supply pop-up spray heads in accordance with materials list and plan. Attach sprinkler to lateral piping with a semi-flexible polyethylene nipple not less than three (3") inches or more than six (6") inches long.

3.6 VALVES

- Supply valves in accordance with materials list and sized according to drawings. Install valves in a level position in accordance with Manufacturer's Specifications. See plan for typical installation of electric valve, valve box.

3.7 WIRING

- A. Supply wire from the automatic sprinkler controls to the valves. No conduit will be required for U.F. wire unless otherwise noted on the plan. Wire shall be tucked under the piping.
- B. A separate wire is required from the control to each electric valve. A common neutral wire is also required from each control to each of the valves served by each particular control.
- C. Bundle multiple wires and tape them together at ten (10') foot intervals. Install ten (10") inch expansion coil at not more than one hundred (100) foot intervals. Make splices waterproof.

3.8 AUTOMATIC SPRINKLER CONTROLS

- Supply in accordance with Irrigation Plan. Install according to manufacturer's recommendations.

3.9 TESTING

- A. Sprinkler Mains: Test sprinkler main only for a period of twelve (12) to fourteen (14) hours under normal pressure. If leaks occur, replace joint or joints and repeat test.
- B. Complete tests prior to backfilling. Sufficient backfill material may be placed in trenches between fittings to insure stability of line under pressure. In each case, leave fittings and couplings open to visual inspection for full period of test.

3.10 FINAL ADJUSTMENT

After installation has been completed, make final adjustment of sprinkler system in preparation for Landscape Architect's final inspection. Completely flush system to remove debris from lines and turning on system. Check sprinklers for proper operation and proper alignment for direction of flow. Check each section of spray heads for operating pressure and balance to other sections by use of flow adjustment and top of each valve. Check nozzle for proper coverage. Prevailing wind conditions may indicate that arch of angle of spray should be other than shown on drawings. In this case, change nozzles to provide correct coverage.

END OF SECTION

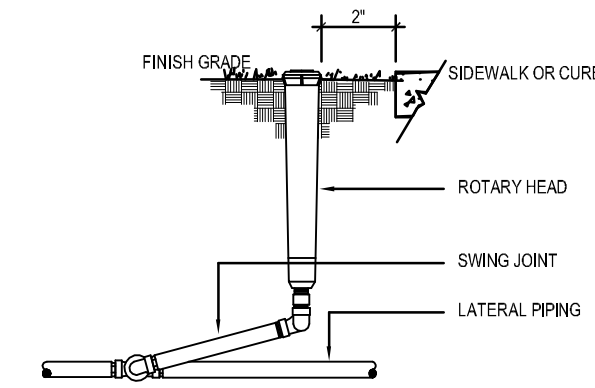

01 ROTARY HEAD NOT TO SCALE

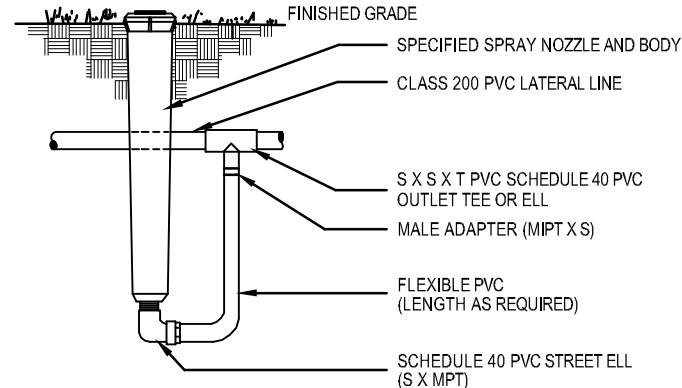

02 HIGH POP-UP SPRAY ASSEMBLY NOT TO SCALE

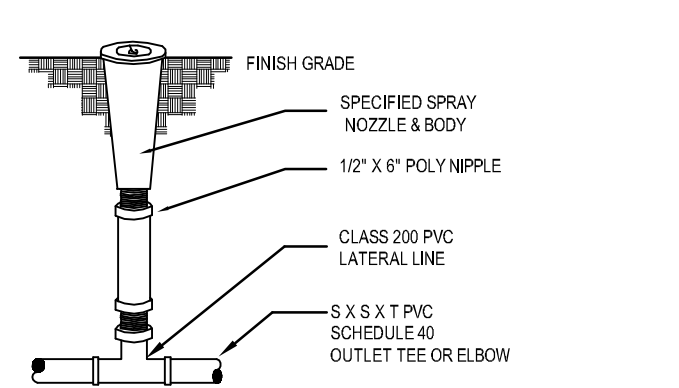

03 POP-UP LAWN SPRAY ASSEMBLY NOT TO SCALE

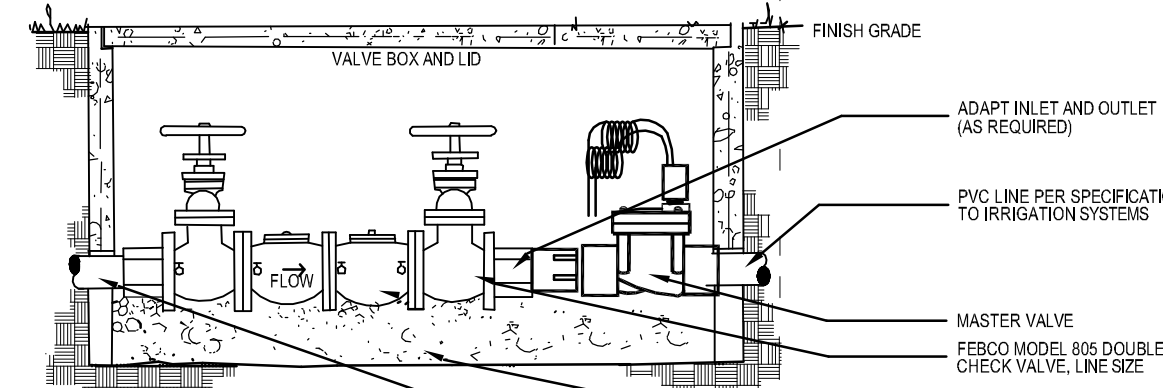

04 BACKFLOW PREVENTER NOT TO SCALE

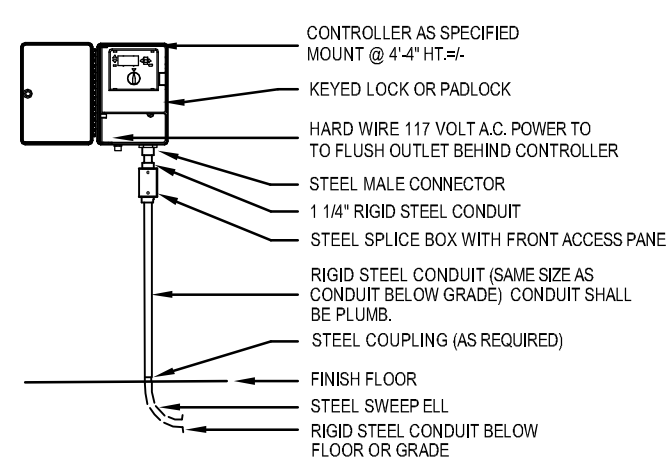

05 WALL MOUNTED CONTROLLER NOT TO SCALE

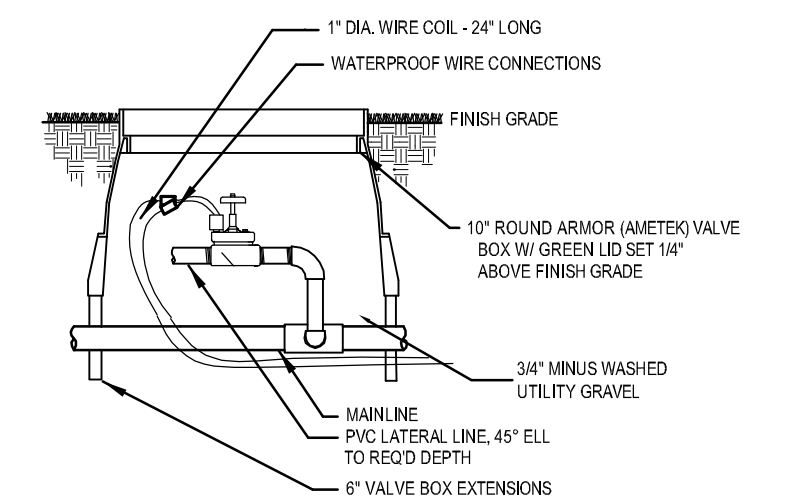

06 REMOTE CONTROL VALVE NOT TO SCALE

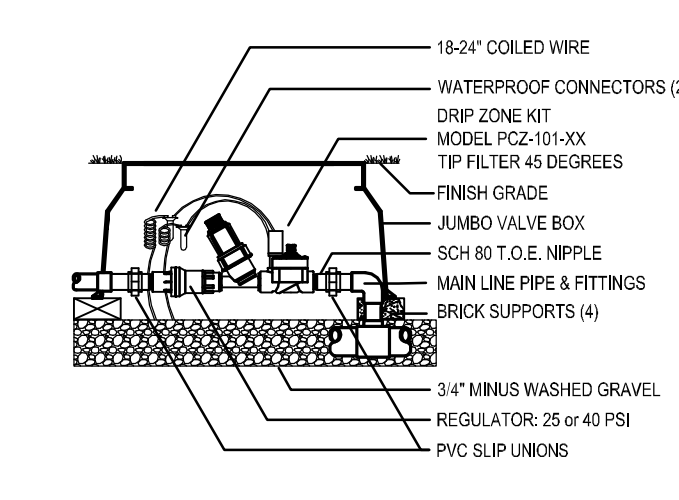

07 DRIP CONTROL VALVE NOT TO SCALE

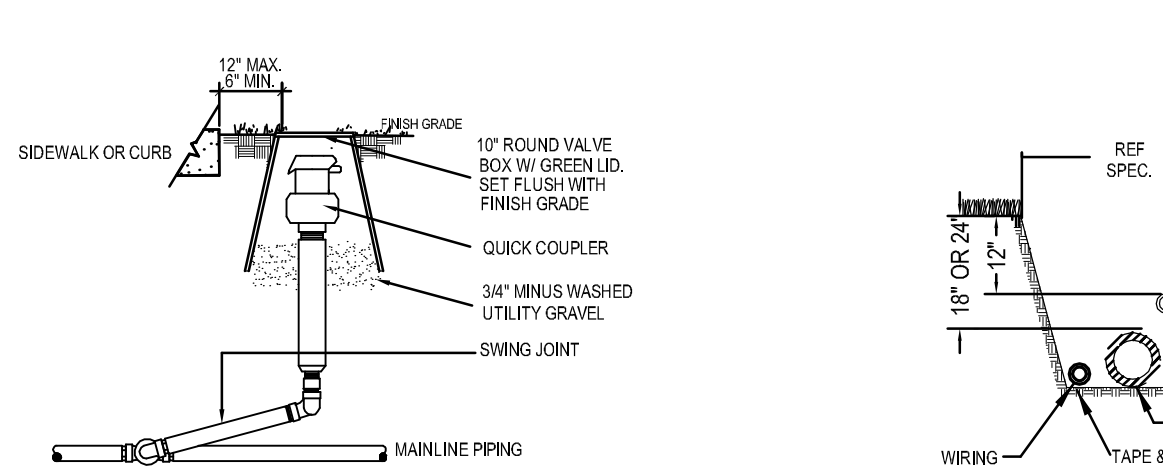

08 QUICK COUPLER NOT TO SCALE

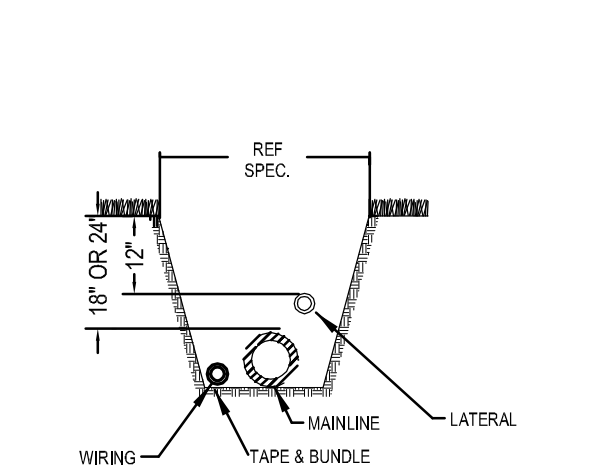

09 TRENCH DETAIL NOT TO SCALE

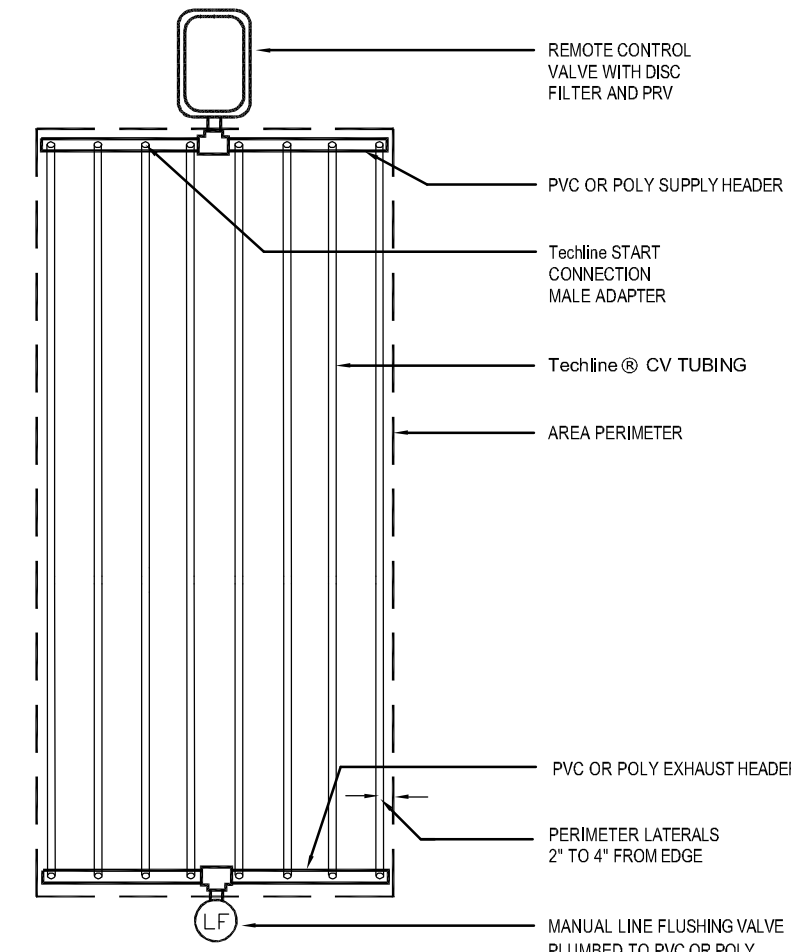

10 TechLine CV END FEED LAYOUT NOT TO SCALE

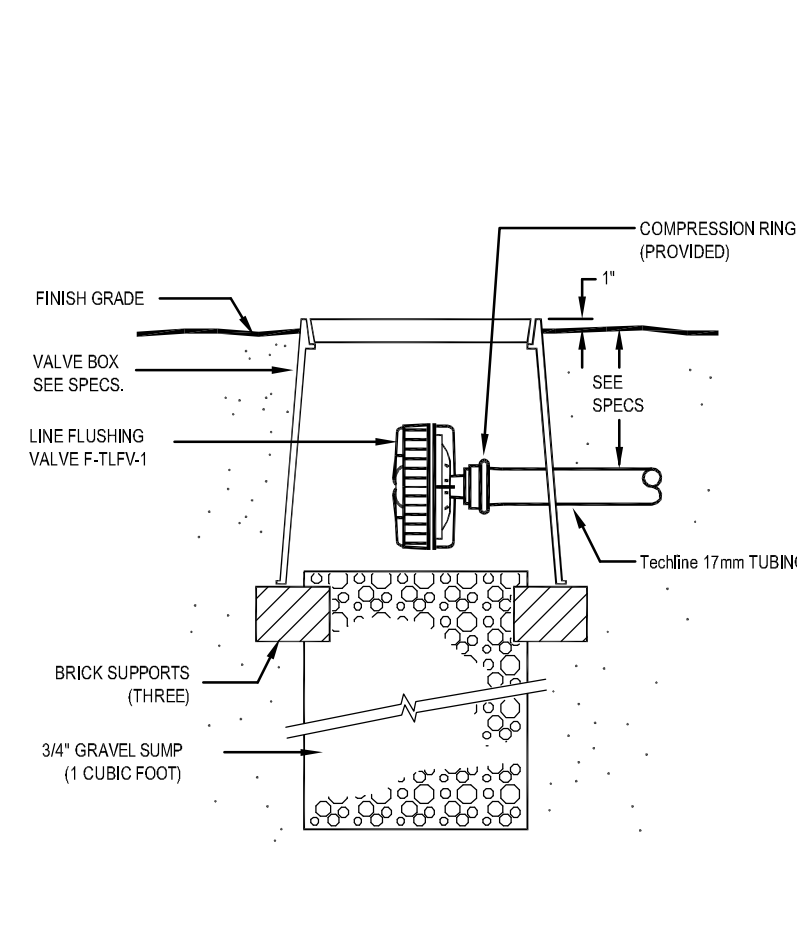

11 TechLine LINE FLUSHING VALVE NOT TO SCALE

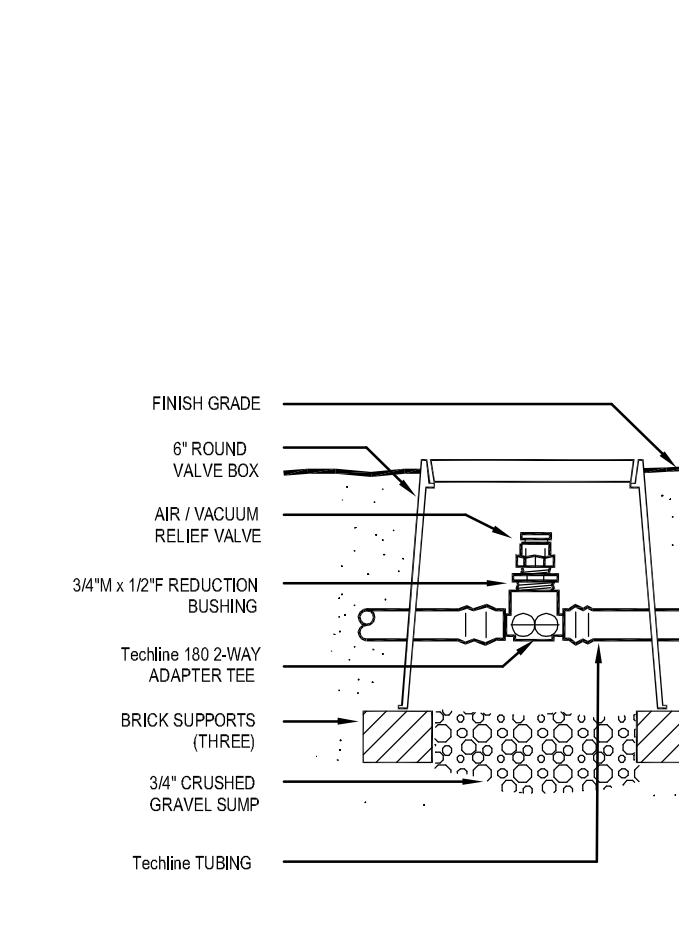

12 TechLine AIR/VACUUM RELIEF NOT TO SCALE

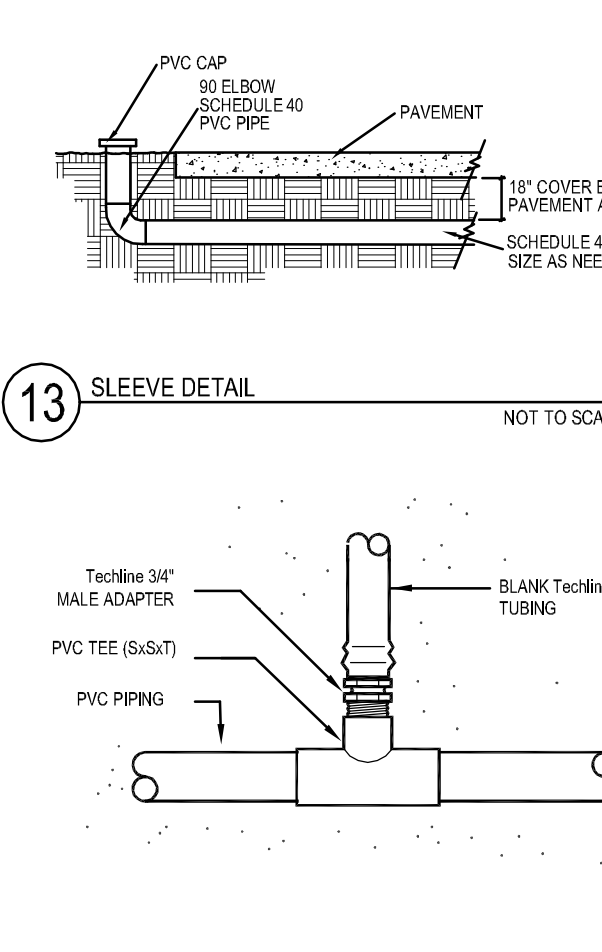

13 SLEEVE DETAIL NOT TO SCALE

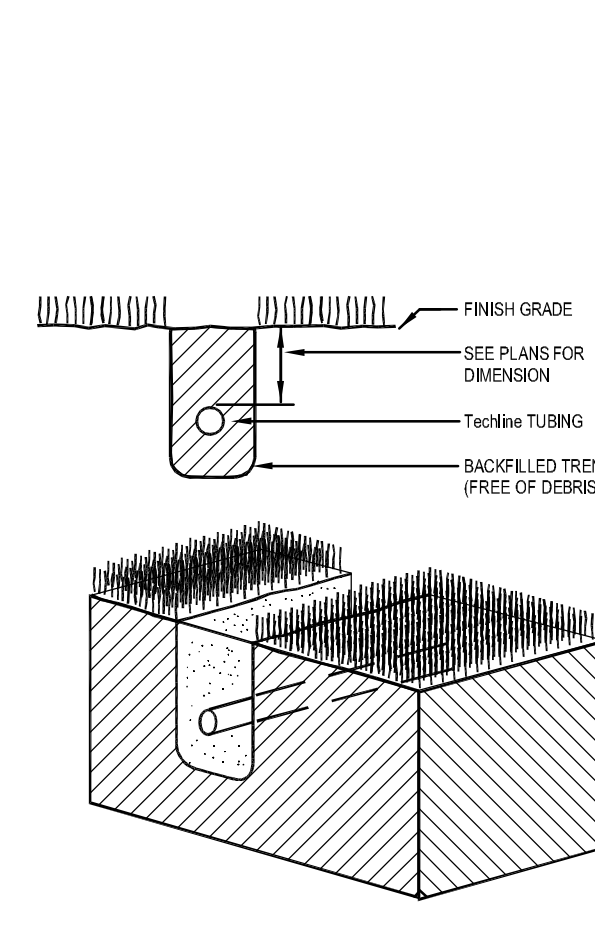

14 TechLine START CONNECTION NOT TO SCALE

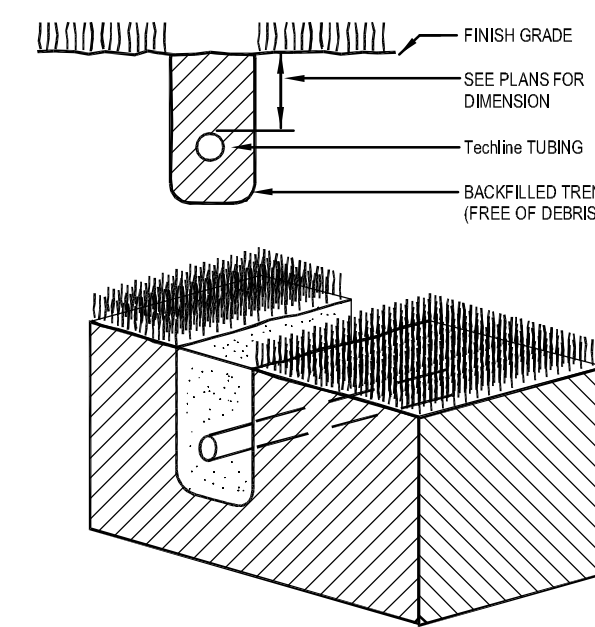

15 TechLine TRENCHING NOT TO SCALE

DONT PLACE IRRIGATION HEADS OR LATERAL LINES ON TOP ANY UTILITY BOXES OR VAULTS

1	10.03.16	SUP SUBMITTAL
2	12.29.16	REVISED SITE PLAN
3	01.19.17	TOWN COMMENTS
4		
5		
6		
7		
8		
9		



SHEET CONTENTS:

**IRRIGATION
SPECIFICATIONS**

DATE: Dec. 29, 2016

SHEET:

L2.2