

NO	DELTA	RADIUS	LENGTH
1	41°02'34"	100.00'	71.63'
2	48°57'26"	78.67'	67.22'

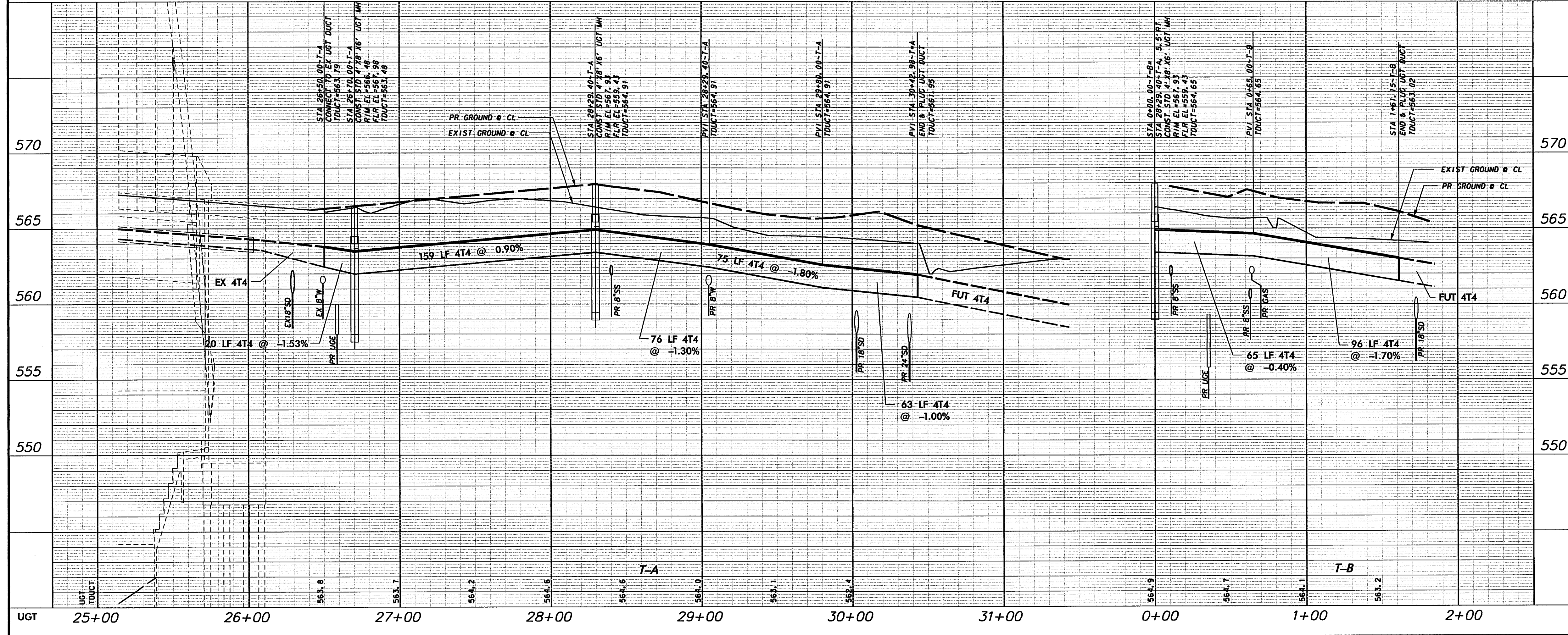
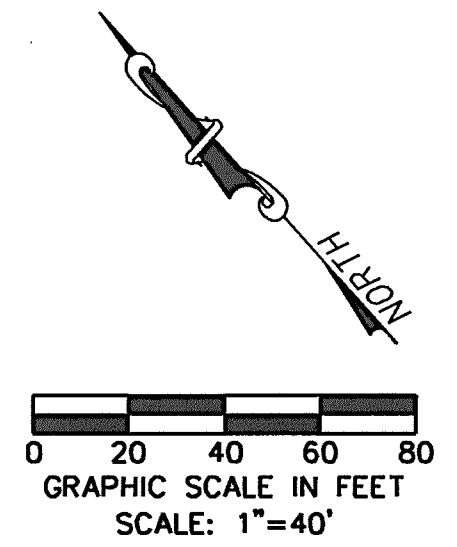
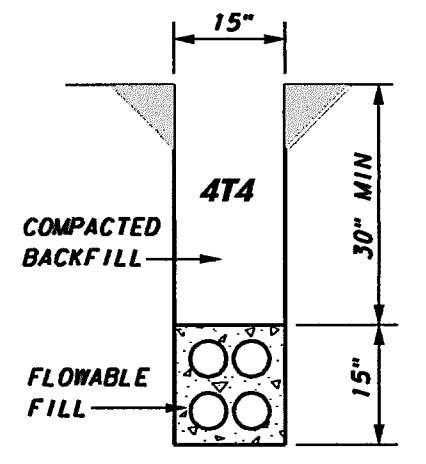

NOTE:
1. SEE OVERALL DUCT BANK PLAN LAYOUT SHEET FOR UGE AND UGT GENERAL NOTES.

WARNING

CONTRACTOR IS TO CONTACT TEXAS ONE-CALL SYSTEM (1-800-245-4545) OR OTHER UTILITY LOCATING SERVICES AT LEAST 48 HOURS PRIOR TO CONSTRUCTION ACTIVITIES. ICON CONSULTING ENGINEERS, INC. IS NOT RESPONSIBLE FOR KNOWING ALL EXISTING UTILITIES IN THE PROJECT AREA NOR FOR DEPICTING THE EXACT LOCATIONS OF UTILITIES ON THESE DRAWINGS.

BM #1 REF. ELEVATION = 559.47
SQUARE CUT IN TOP OF CURB, SOUTH MEDIAN END NOSE, MARSH LANE 1127' NORTH OF VITRUVIAN WAY.

BM #2 REF. ELEVATION = 547.84
SQUARE CUT IN TOP OF CURB, NORTH MEDIAN END NOSE, AT INTERSECTION OF VITRUVIAN WAY AND MARSH LANE.

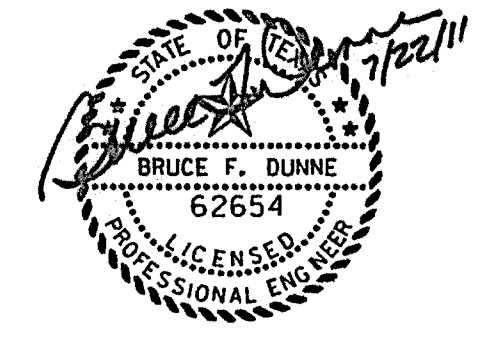
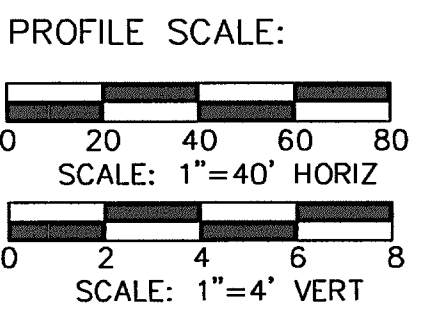

NO.	REVISION	BY	DATE

ADDISON TOWN OF ADDISON
DALLAS COUNTY, TEXAS

PAVING, DRAINAGE & UTILITY IMPROVEMENTS
PONTE AVENUE CIRCLE

DUCT BANK PLAN & PROFILE
TELEPHONE

PROJECT	DESIGN	DRAWN	DATE	FILE	SHEET
5019-09	ICE	ICE	JULY 22, 2011	PW# 2011-03	26

PAVING, DRAINAGE, & UTILITY IMPROVEMENTS - PONTE AVENUE CIRCLE