

SAVOYE

UNDERGROUND NOTES:

- UTILITIES TO START WORK AT THE TAP AND TRI DAL LTD. TERMINATE INSIDE THE BUILDING @ 1 FT. A.F.F.
1. TRI DAL LTD. TO INSTALLED UNDERGROUND FIRE SERVICE MAIN TO MEET THE REQUIREMENTS OF THE 2010 EDITION OF NFPA 13 AND NFPA 24, AND THE AUTHORITY HAVING JURISDICTION.
 2. ALL NEW INSTALLATIONS TO CONFORM TO THE CITY OF ADDISON PUBLIC WORKS, FIRE DEPARTMENT, NFPA #13, AND NFPA #24 STANDARDS.
 3. ---LEAD-IN PIPING TO BE AWMA C-900 PVC CLASS 200. PIPE ENTERING THE BUILDING SHALL BE CLASS 51 DUCTILE WITH POLYWRAP.
 4. ALL FITTINGS TO BE RODDED AND/OR THRUST BLOCKED IN ACCORDANCE WITH NFPA #24 AND NFPA #13.
 5. PIPE SHALL BE VISUALLY INSPECTED PRIOR TO BACKFILL AND HYDROSTATICALLY TO 200 PSI FOR 2 HOURS OR AS REQUIRED BY THE CITY STANDARD.
 6. PIPING TO MAINTAIN 42 INCH MINIMUM COVER BELOW GRADE. TRENCHES ARE TO BE BACKFILLED WITH THE SPECIFIED EMBEODMENT FOR THE AREA OF JURISDICTION AND COMPACTED INTO PLACE.
 7. ALL PIPING ARE TO BE FLUSHED AND TESTED IN ACCORDANCE WITH NFPA #24.
 8. ALL PIPING AND TESTING TO BE WITNESSED BY THE LOCAL AUTHORITIES PRIOR TO BACKFILLING.

TO EXISTING 8" WATER REMOVE PLUG AND INSTALL:
66 L.F. OF 8" FIRE LINE
1-8" RISER TO 1' A.F.F.
(per city standards)

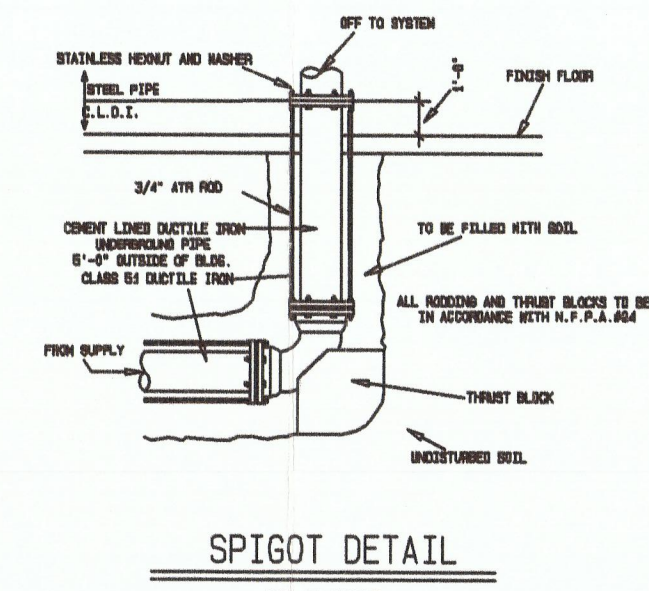

OWNER D C O Greenhaven LP
ADDRESS 5430 Lbj Freeway, Suite 1250 Dallas, TX
PERMIT#

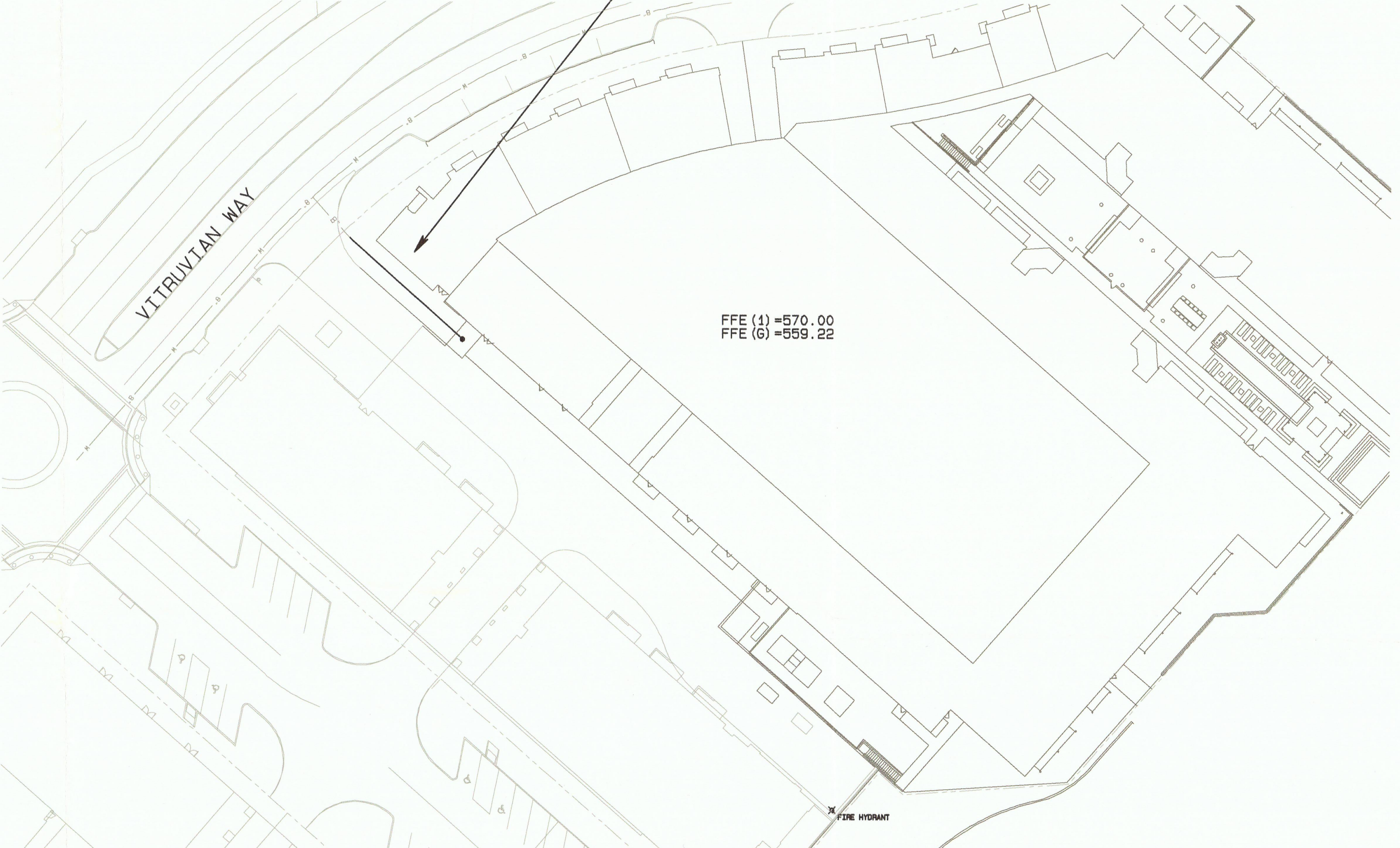
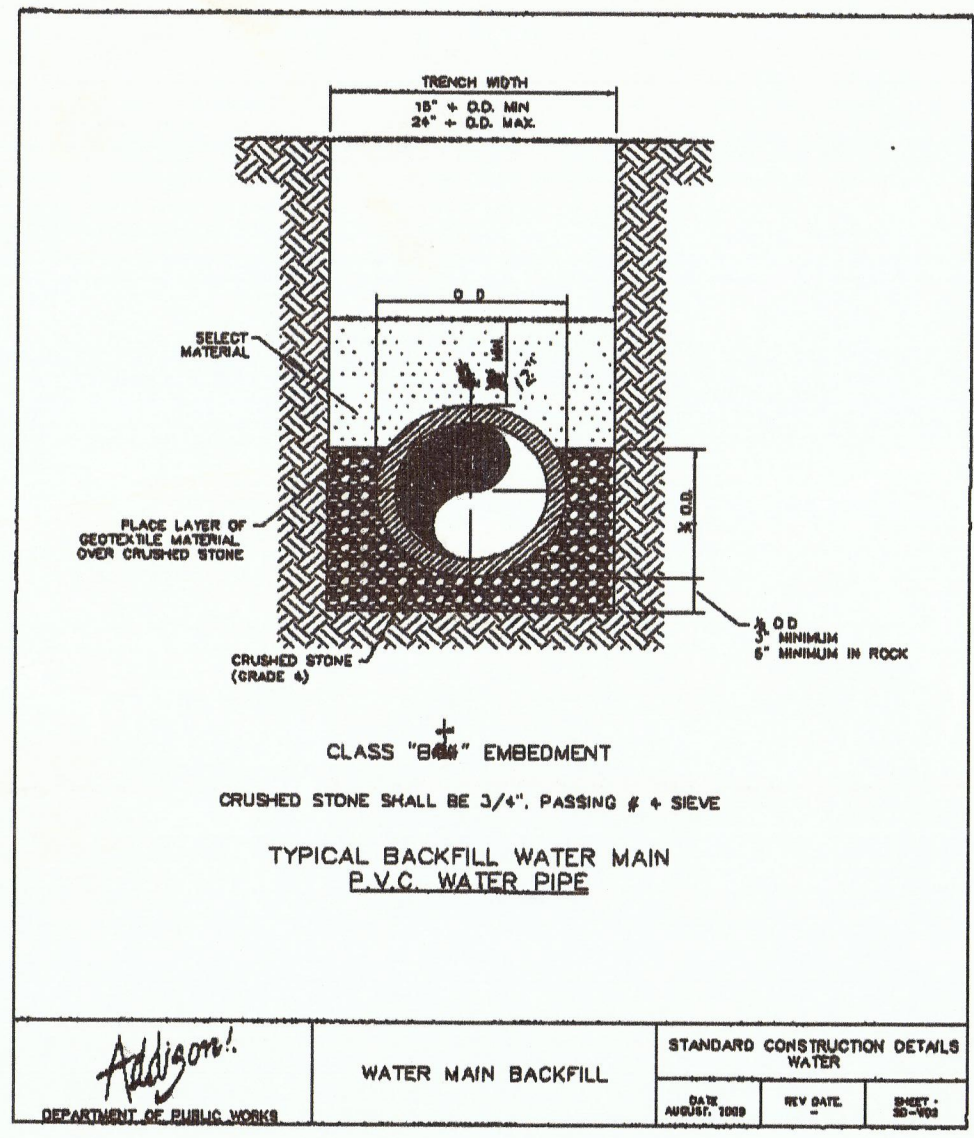

AREA OF BEARING FACE OF CONCRETE THRUST BLOCKS

PIPE SIZE INCHES	90 DEGREE BEND SQ. FT.	45 DEGREE BEND SQ. FT.	TEES, PLUGS, CAPS AND HYDRANTS SQ. FT.
4	2	2	2
6	5	3	4
8	8	5	6
10	13	7	9
12	18	10	13
14	25	14	18
16	32	18	23
18	42	22	29
20	51	28	36
24	74	40	52

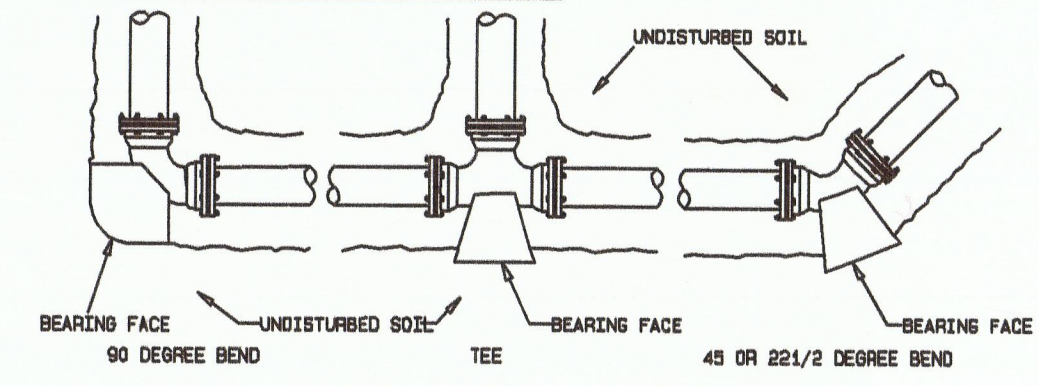

CONCRETE THRUST BLOCK DETAILS
NOT TO SCALE

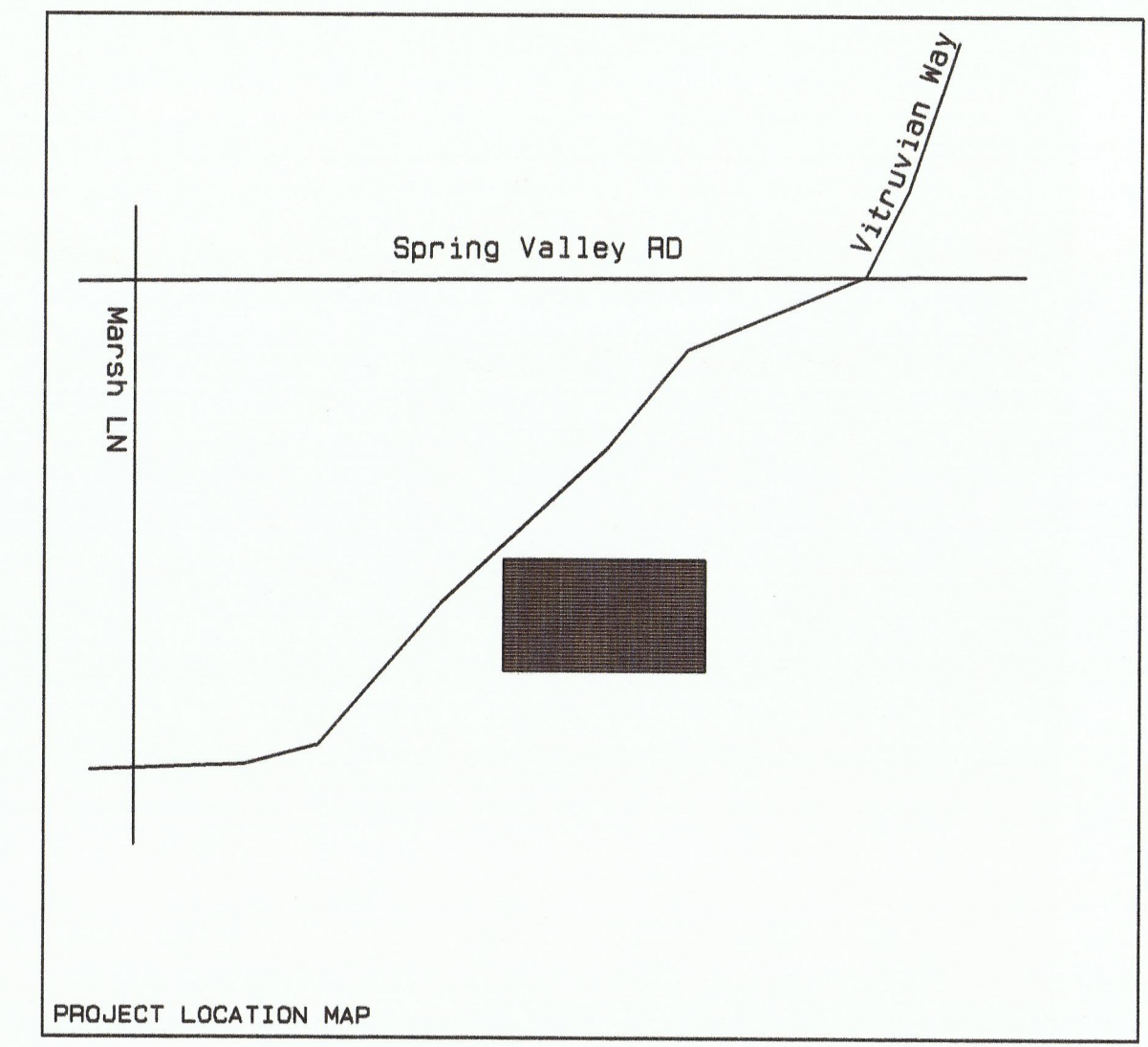

others to install a double check detector assembly with an externally mounted touch pad in the riser room. Meter to be in accordance with the Town of Addison Water System Requirements

INSTALLATION AND TESTING BY TRI DAL LTD.
540 Commerce
Southlake, Texas, 76092
www.tridal.com
817 481-2886 fax 817 481-8195

FIRE LEAD-INS DESIGNED BY EXCEL CONSULTANTS
5205 TACOMA
ARLINGTON, TX 76017
(817) 271-4344
Elias S. Bathish PE
REG # F-8352

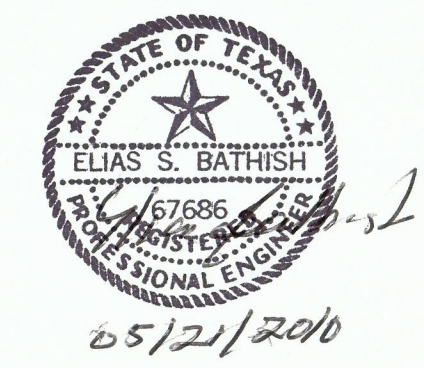

APPROVED FOR CONSTRUCTION
Town of Addison
Public Works Department
APPROVED BY: CLAY DARNETT
DATE: 5-21-2010

All responsibility for the adequacy of these plans remains with the Engineer who prepared them. In approving these plans, the Town of Addison makes no representation of adequacy of the work of the Design Engineer.

IN LOCALITIES SUBJECT TO FREEZING CONDITIONS, IT IS THE OWNER'S RESPONSIBILITY TO PROVIDE HEAT THROUGHOUT WET PIPE SPRINKLER SYSTEMS AREAS AND IN ENCLOSURES FOR DRY PIPE DELUGE AND OTHER TYPES OF VALVES CONTROLLING WATER SUPPLIES TO SPRINKLER SYSTEMS.

THIS DRAWING AND THE INFORMATION AND DESIGN APPLICATION HEREIN CONTAINED IS THE PROPERTY OF THE UTILITY CONTRACTOR. AND/OR ITS SUBSIDIARIES AND IS LOANED UPON EXPRESS CONDITIONS THAT THE SAME BE RETURNED TO TRI DAL LTD. UPON REQUEST; ALL INFORMATION HEREIN CONTAINED SHALL BE TREATED AS SECRET, AND CONFIDENTIAL; NO REPRODUCTION OF THIS DRAWING OR ANY PART THEREOF SHALL BE MADE WITHOUT WRITTEN CONSENT OF TRI DAL LTD.

CONTRACT NAME	Vitruvian Park Block 102 3875 Ponte Avenue Addison, TX	TEXAS STATE LICENSE NO.	SCR: 0415U
		RPE LICENSE NO.	RME-1229-U
		BY:	BRYCE, JAMES COLIN
		RPE SIGNATURE:	<i>James Bryce</i>
		DRAWN BY:	JCB
		DATE:	Mon May 03 10:19:54 2010
		SCALE:	AS SHOWN
		DRAWING NO.	1 OF 1
CONTRACT WITH	TRI DAL LTD. 540 Commerce Southlake, Texas, 76092 www.tridal.com 817 481-2886 fax 817 481-8195		
DESCRIPTION			

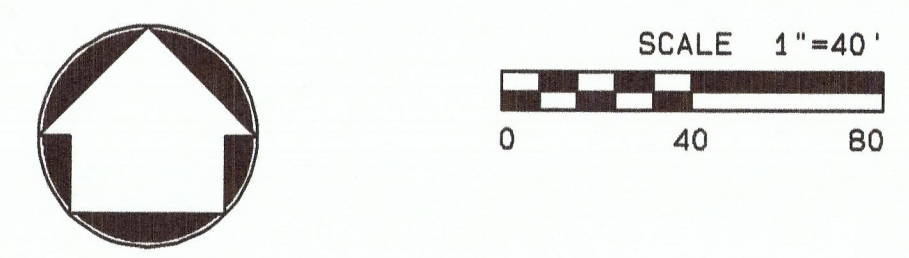

Vitruvian Park Block 102
3875 Ponte Avenue
Addison, TX

Tri Dal Ltd.
SCR# 0415U
540 Commerce
Southlake, Texas, 76092
www.tridal.com
817 481-2886 fax 817 481-8195