

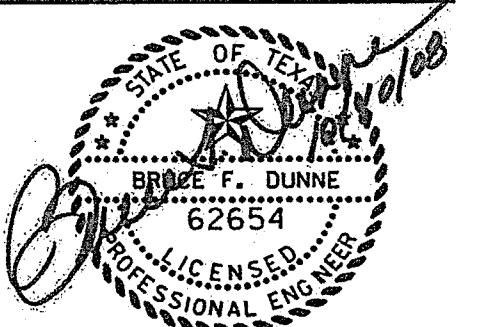

CONSTRUCTION	10/13/08
PERMIT	7/21/08

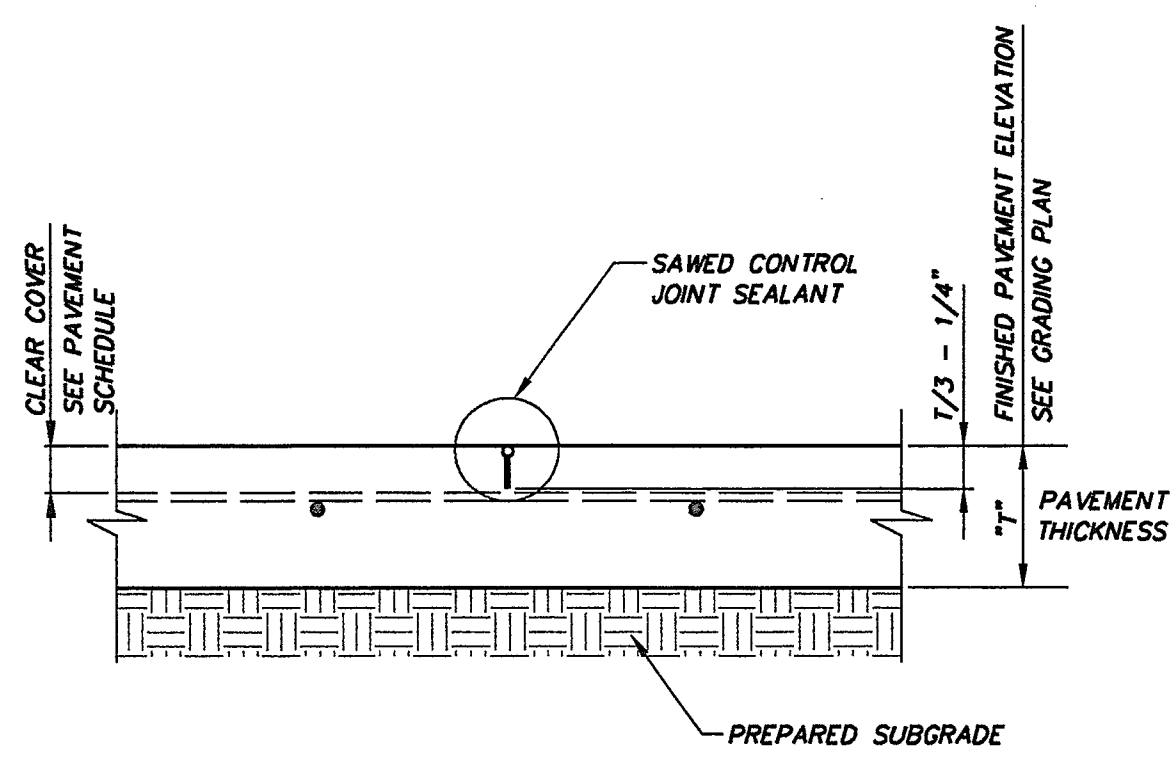

PAVING DETAILS



LONGITUDINAL CONTROL JOINT
NOT TO SCALE

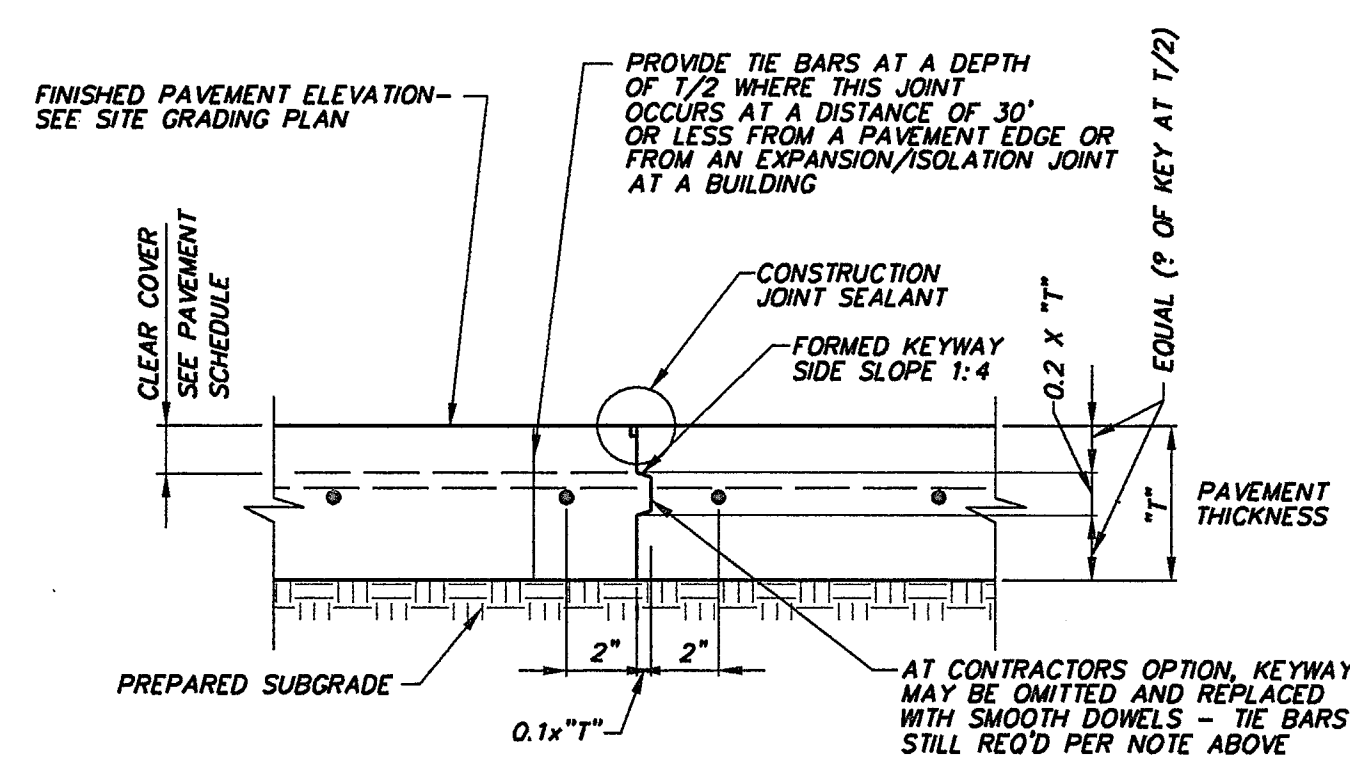

KEYED LONGITUDINAL CONSTRUCTION JOINT
NOT TO SCALE

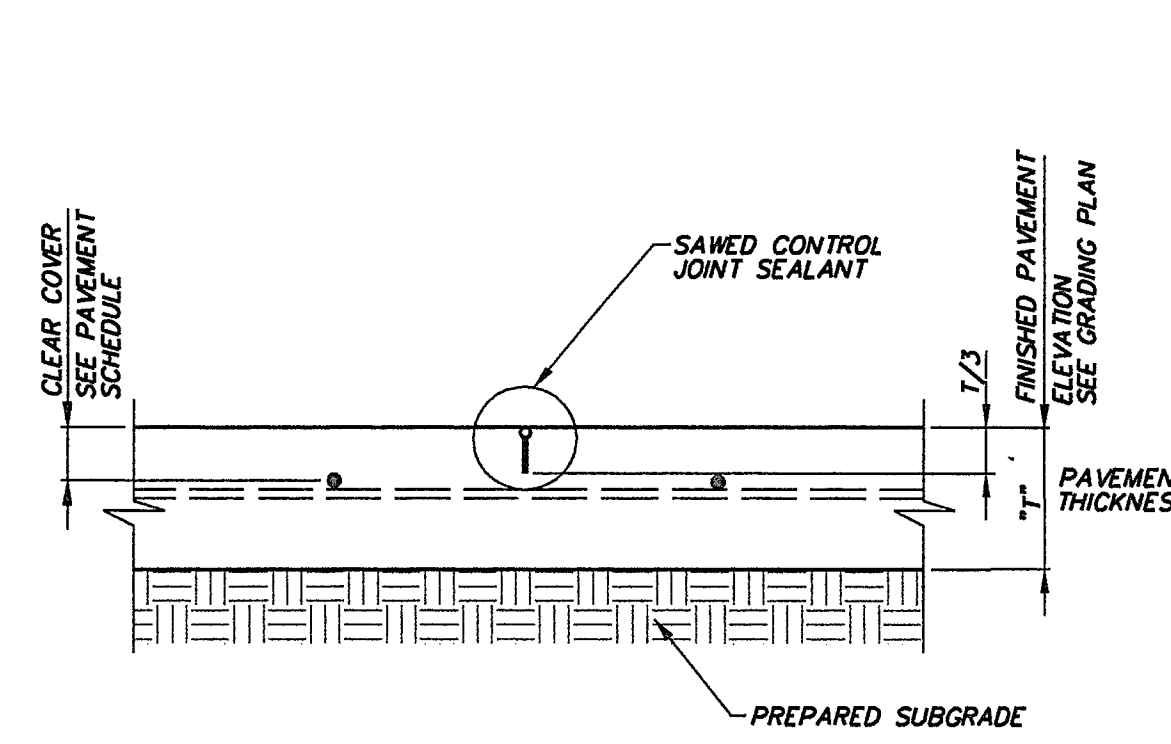

TRANSVERSE CONTROL JOINT
NOT TO SCALE

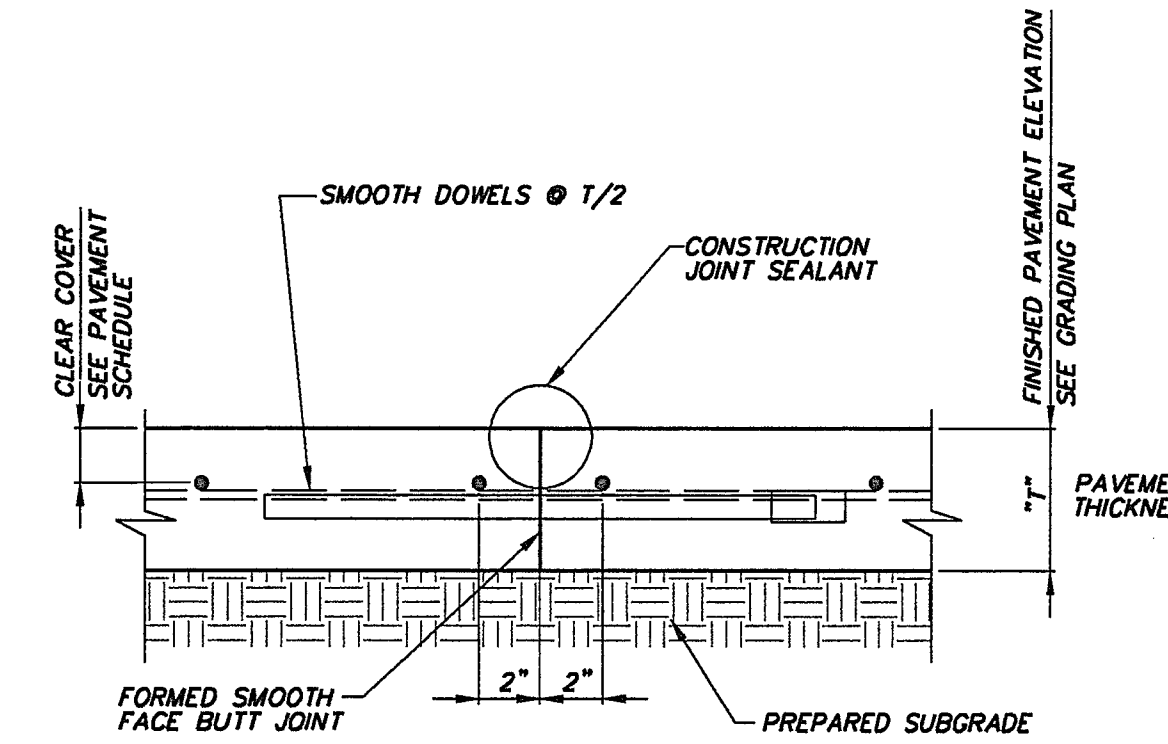

TRANSVERSE CONSTRUCTION JOINT
NOT TO SCALE

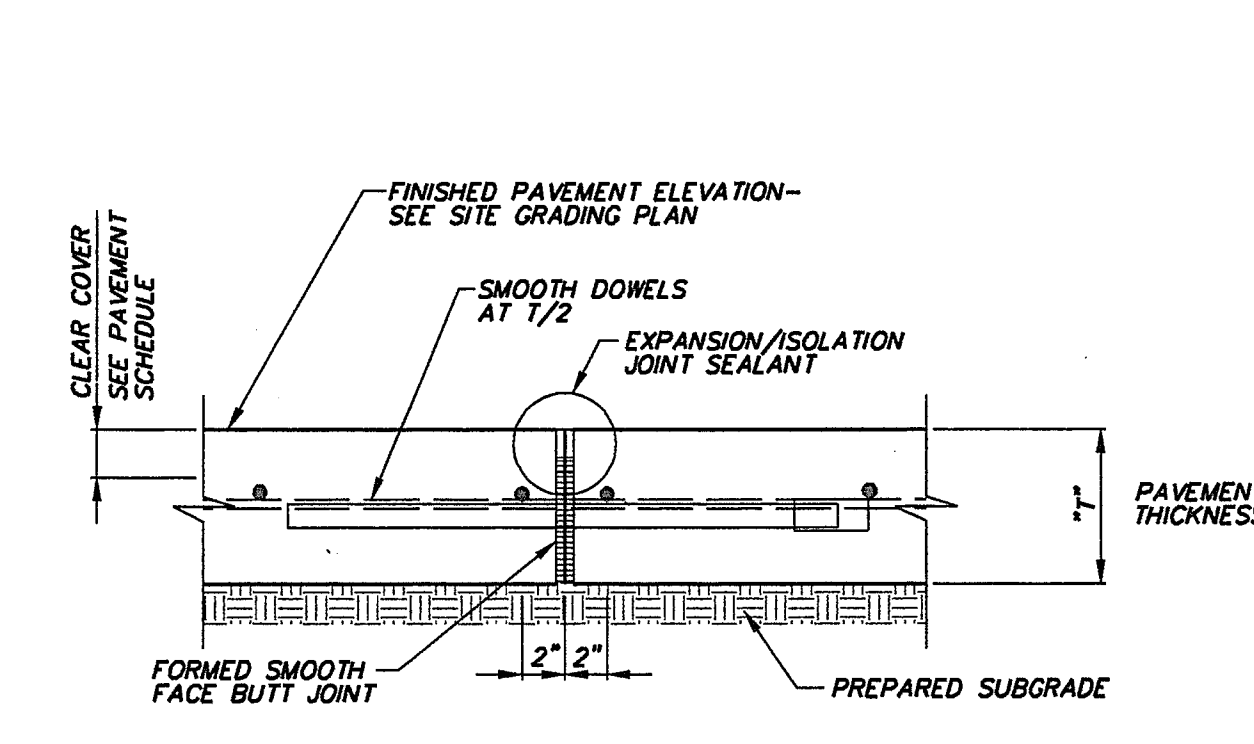

TRANSVERSE EXPANSION JOINT
NOT TO SCALE

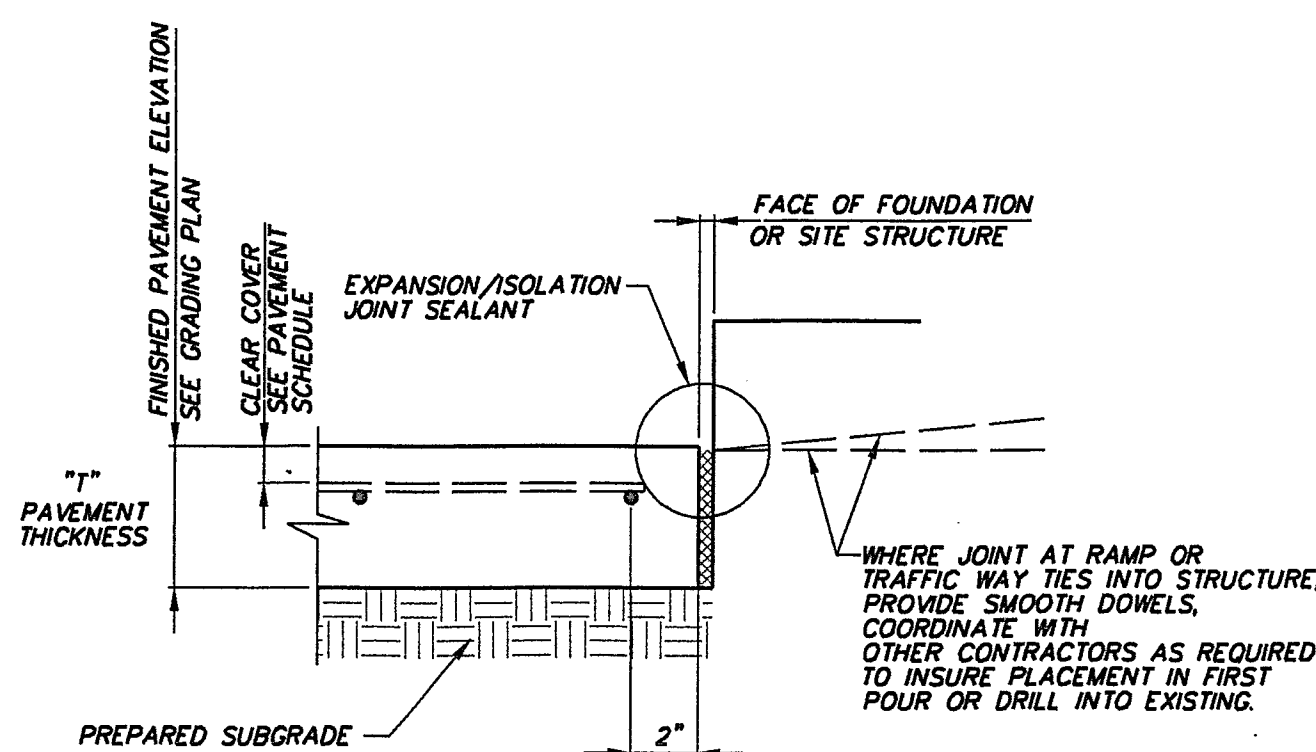

EXPANSION / ISOLATION JOINT AT STRUCTURES
NOT TO SCALE

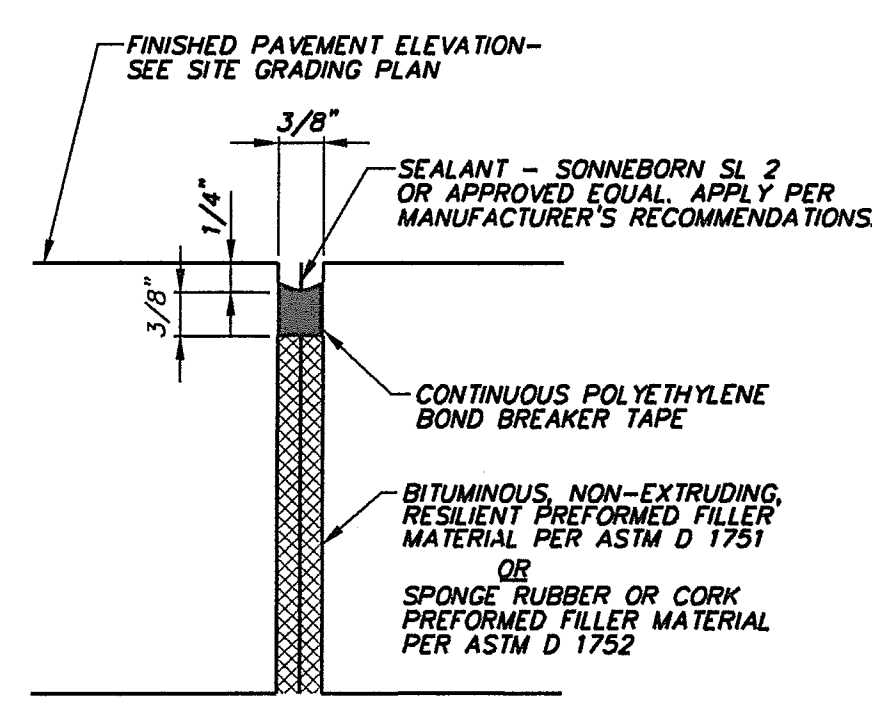

EXPANSION / ISOLATION JOINT SEALANT
NOT TO SCALE

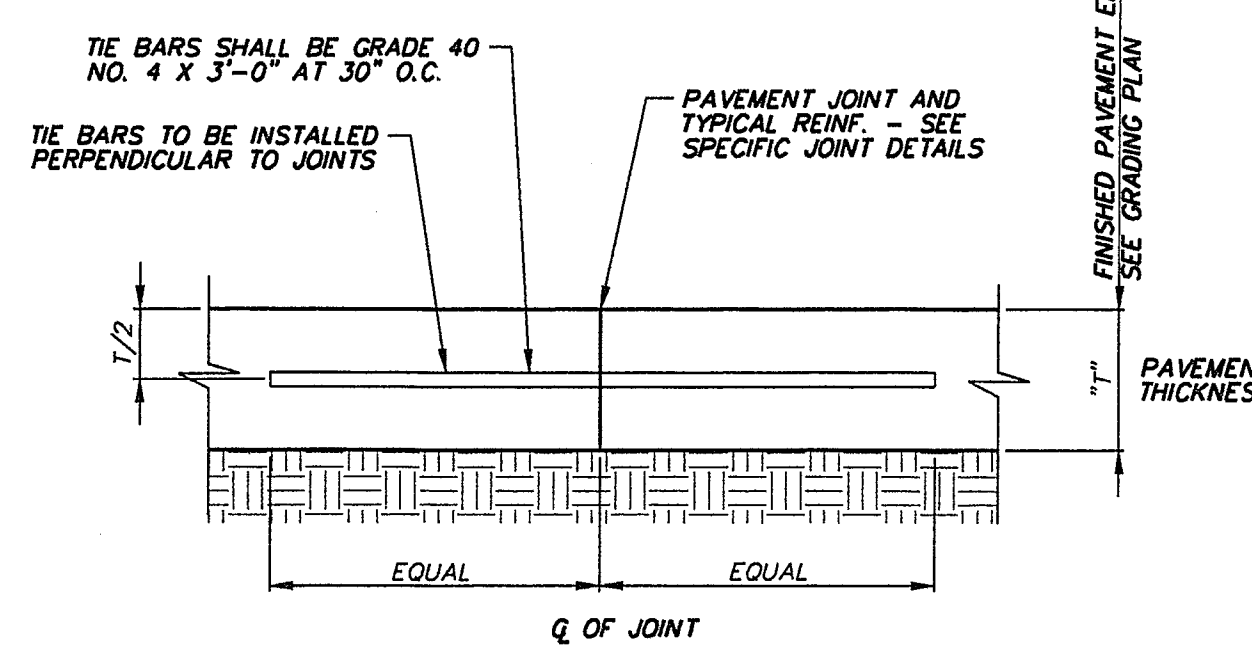

TIE BAR
NOT TO SCALE

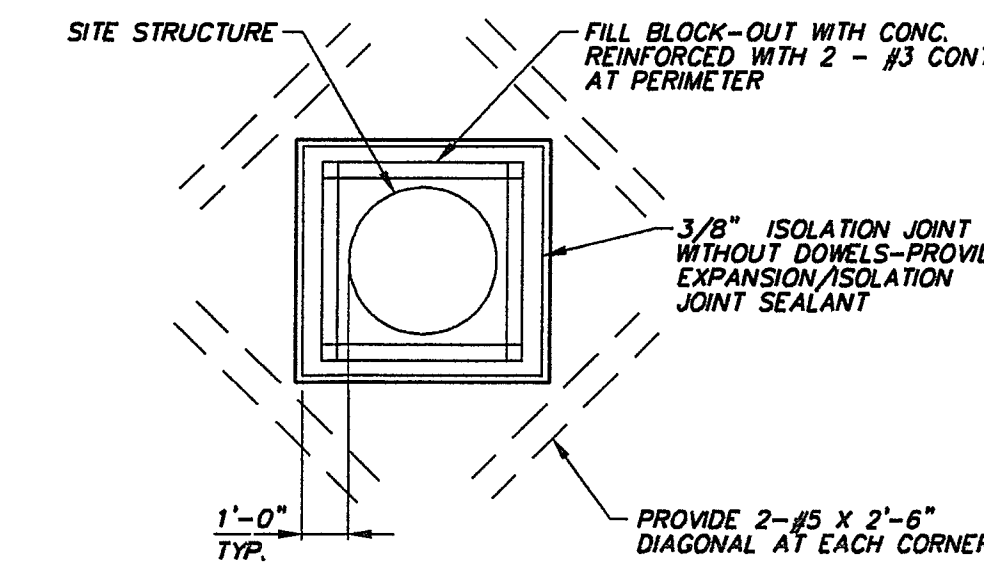

JOINT TREATMENT AT SITE STRUCTURES
NOT TO SCALE

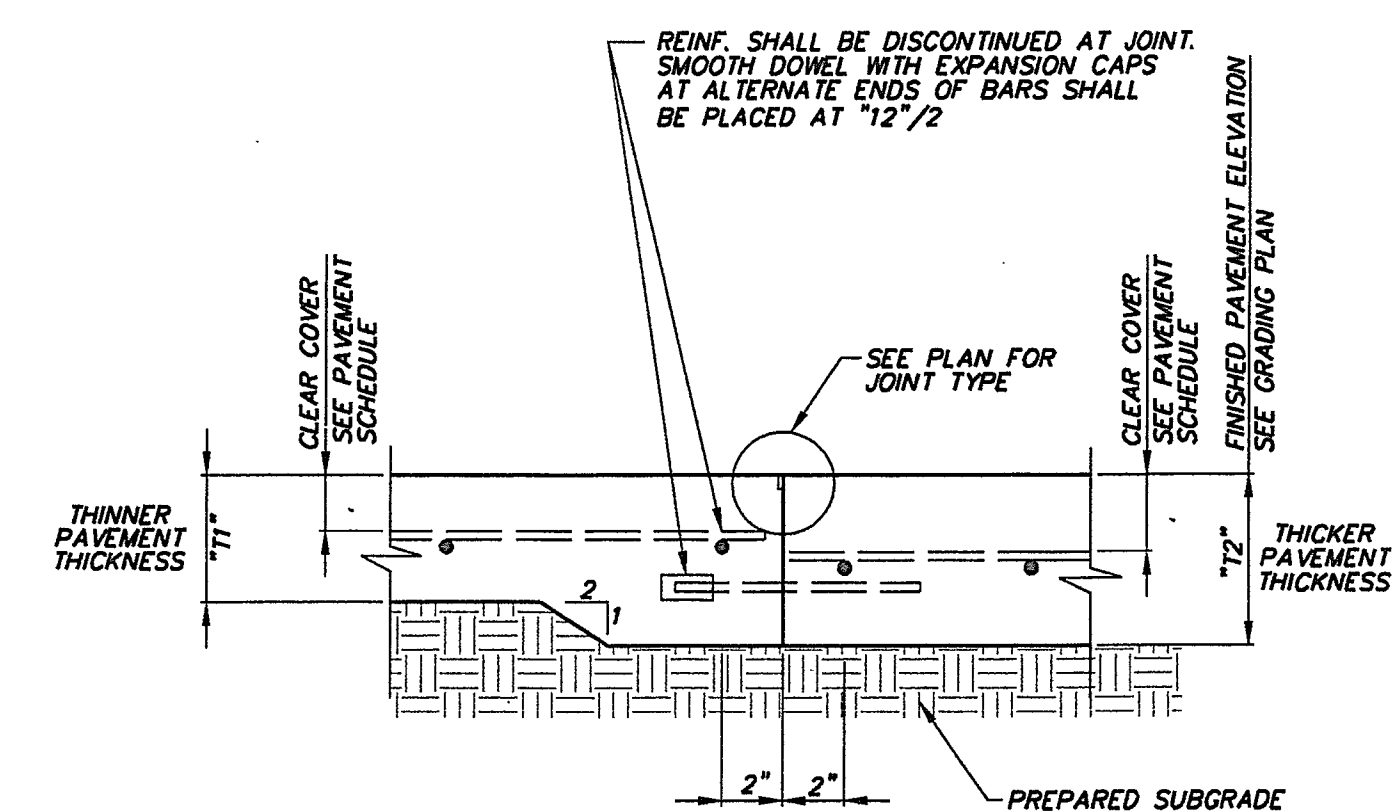

PAVEMENT DEPTH CHANGE / ISOLATION JOINT
NOT TO SCALE

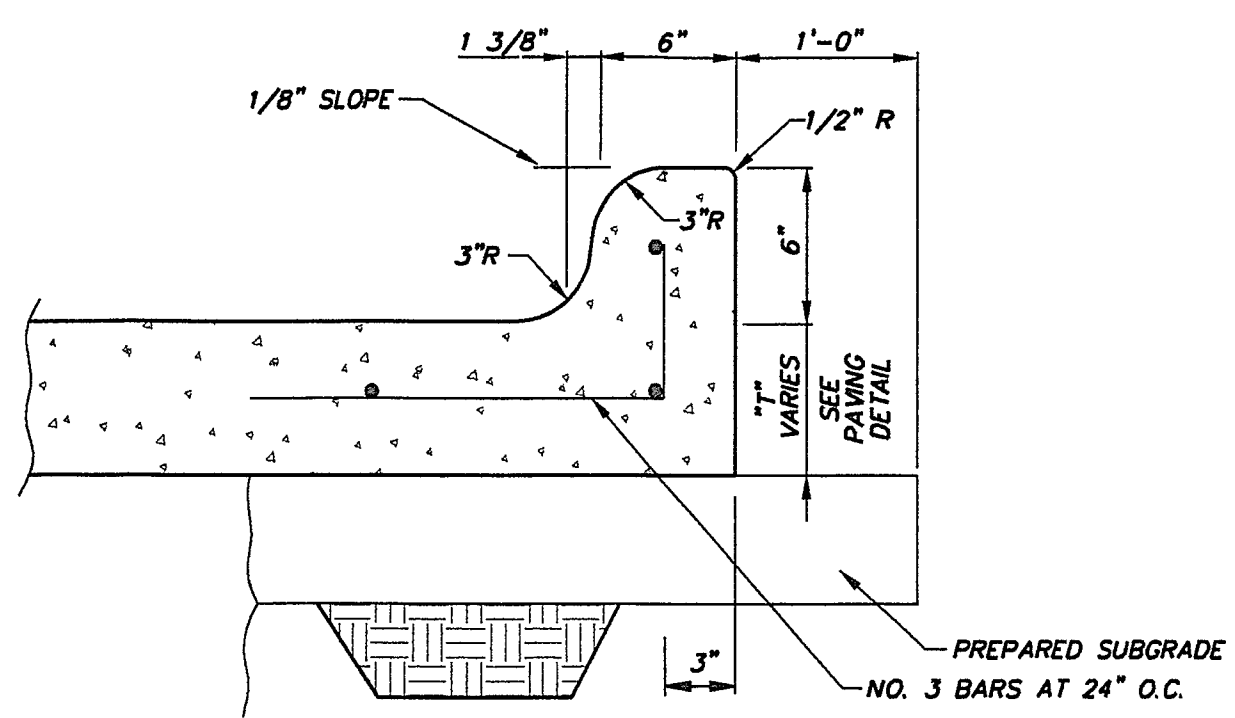

6\"/>

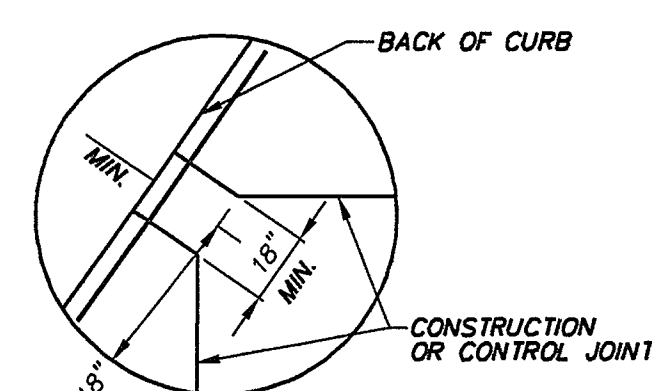

TYPICAL AT ALL ANGLED JOINT TERMINATIONS
NOT TO SCALE

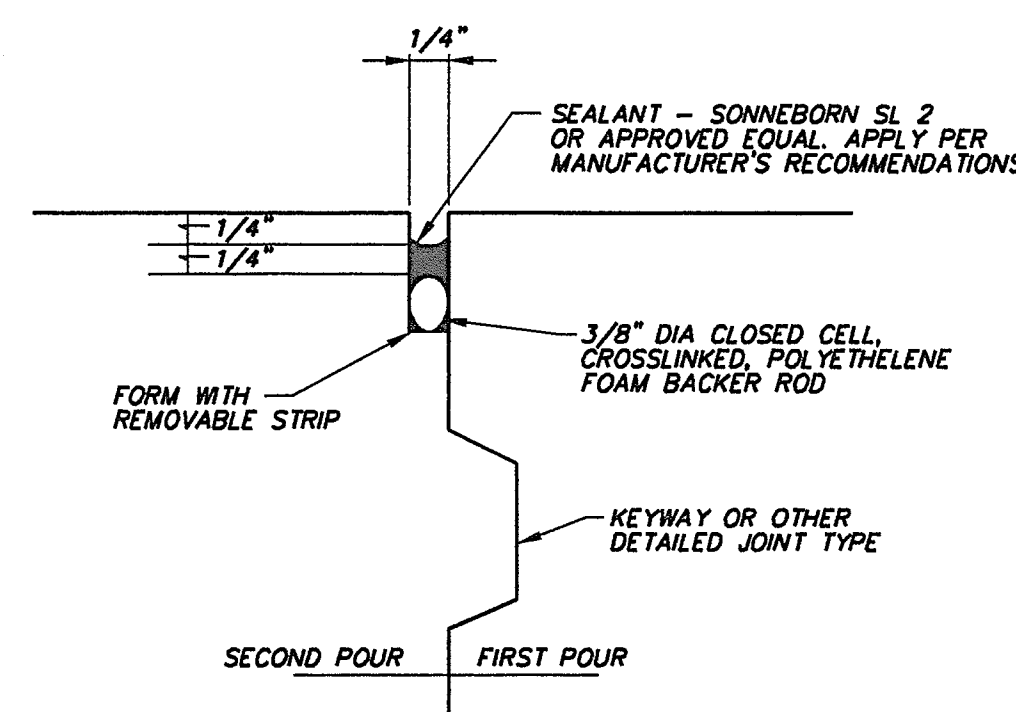

CONSTRUCTION JOINT SEALANT
NOT TO SCALE

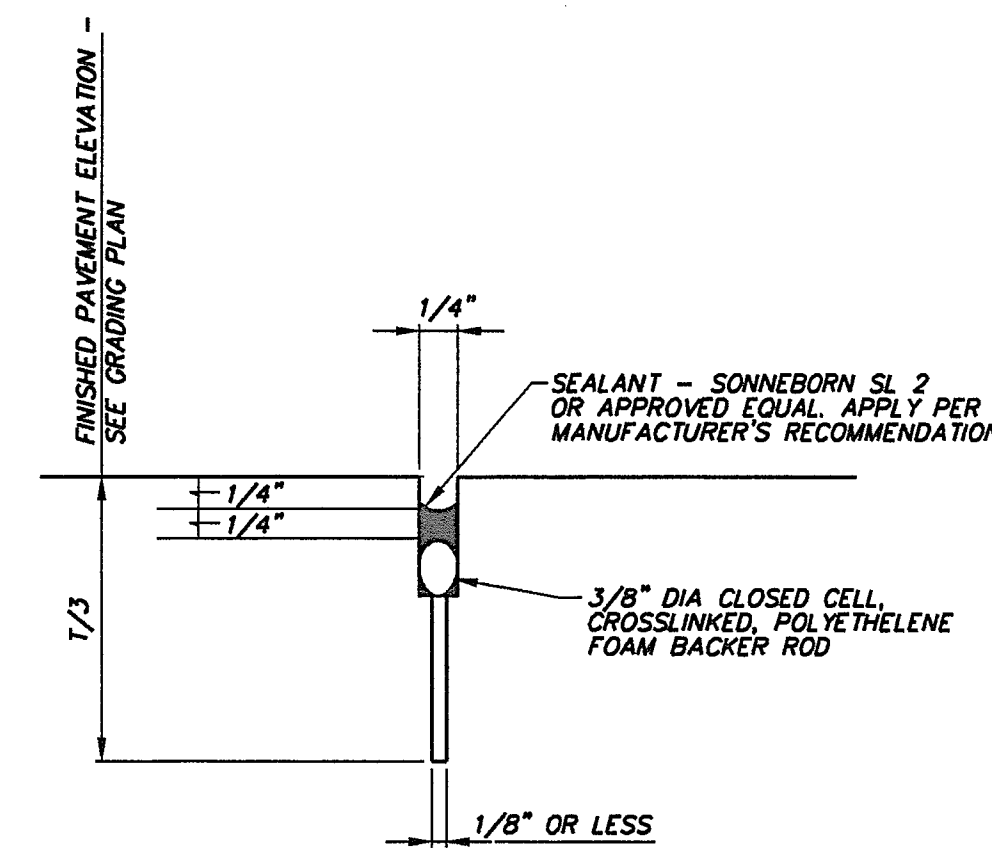

SAWED CONTROL JOINT SEALANT
NOT TO SCALE

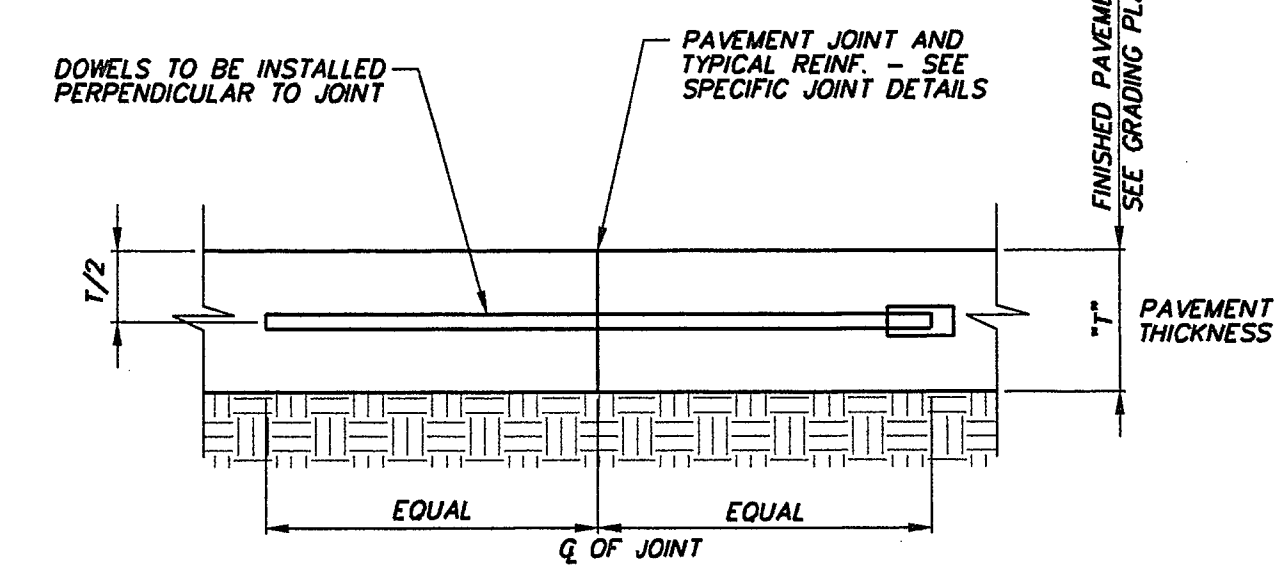

SMOOTH DOWEL
NOT TO SCALE

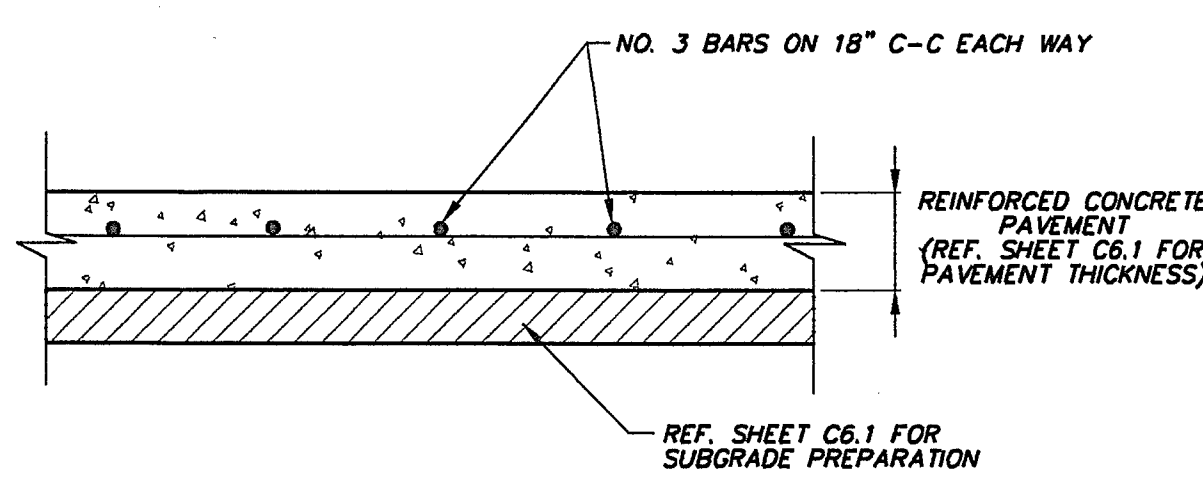

TYPICAL PAVEMENT SECTION
NOT TO SCALE

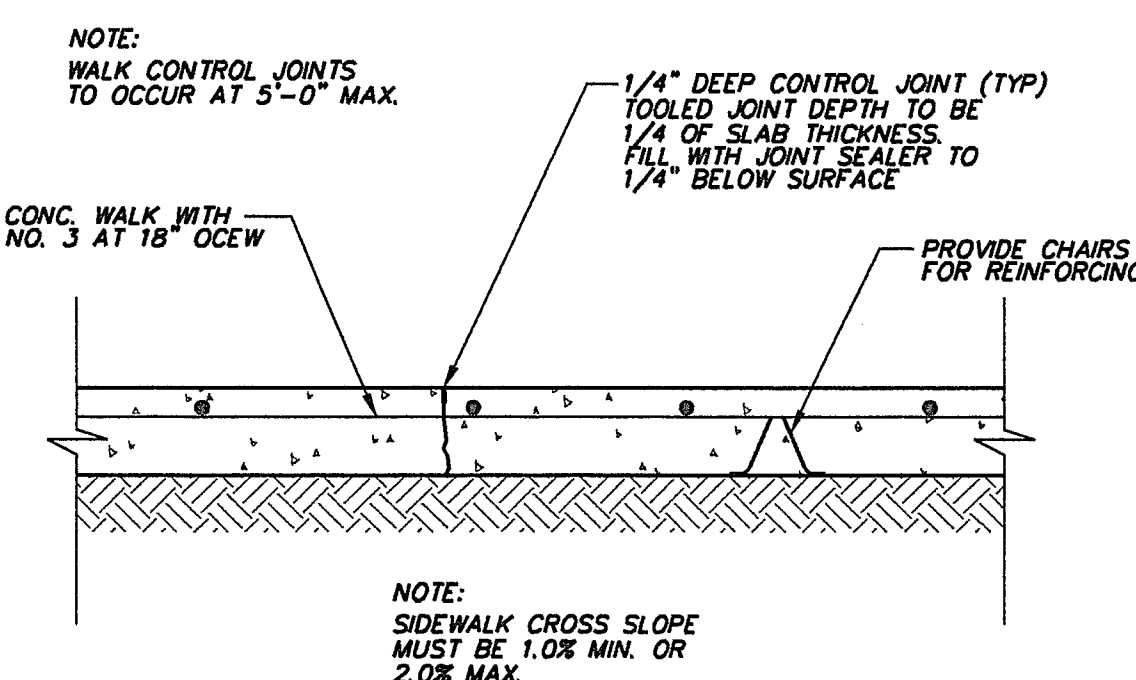

SIDEWALK CONTROL JOINT
NOT TO SCALE

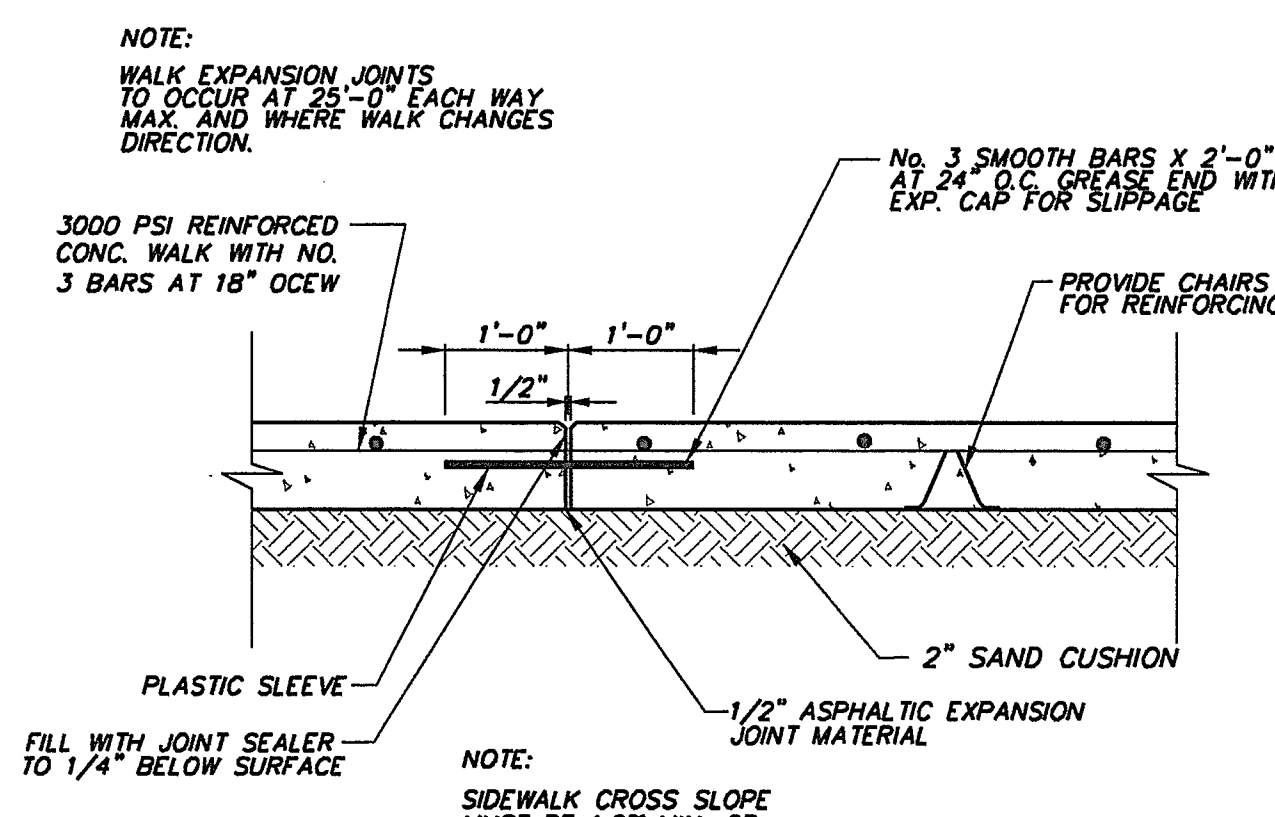

SIDEWALK EXPANSION JOINT
NOT TO SCALE