

- NOTES:**
1. STONE SIZE: 3"-5" CRUSHED ROCK OR ACCEPTABLE CRUSHED PORTLAND CEMENT CONCRETE.
  2. LENGTH: AS EFFECTIVE, BUT NOT LESS THAN 30 FEET.
  3. THICKNESS: NOT LESS THAN 6".
  4. WIDTH: NOT LESS THAN FULL WIDTH OF ALL POINTS OF INGRESS OR EGRESS.
  5. WASHING: WHEN NECESSARY, WHEELS SHALL BE CLEANED TO REMOVE SEDIMENT PRIOR TO ENTRANCE ONTO PUBLIC ROADWAY. WHEN WASHING IS REQUIRED, IT SHALL BE DONE ON AN AREA STABILIZED WITH CRUSHED STONE WHICH DRAINS INTO AN APPROVED TRAP OR SEDIMENT BASIN. ALL SEDIMENT SHALL BE PREVENTED FROM ENTERING ANY STORM DRAIN, DITCH OR WATERCOURSE USING APPROVED METHODS.
  6. MAINTENANCE: THE ENTRANCE SHALL BE MAINTAINED IN CONDITION WHICH WILL PREVENT TRACKING OR FLOWING OF SEDIMENT ONTO PUBLIC ROADWAYS. THIS MAY REQUIRE PERIODIC TOP DRESSING WITH ADDITIONAL STONE AS CONDITIONS DEMAND. AND REPAIR AND/OR CLEANOUT OF ANY MEASURES USED TO TRAP SEDIMENT. ALL SEDIMENT SPILLED, DROPPED, WASHED, OR TRACKED ONTO PUBLIC ROADWAY, MUST BE REMOVED IMMEDIATELY.
  7. DRAINAGE: ENTRANCE MUST BE PROPERLY GRADED OR INCORPORATE A DRAINAGE SWALE TO PREVENT RUNOFF FROM LEAVING THE CONSTRUCTION SITE.
  8. CONTRACTOR TO COORDINATE EXACT LOCATION OF THIS DETAIL.

**STABILIZED CONSTRUCTION ACCESS**  
NOT TO SCALE

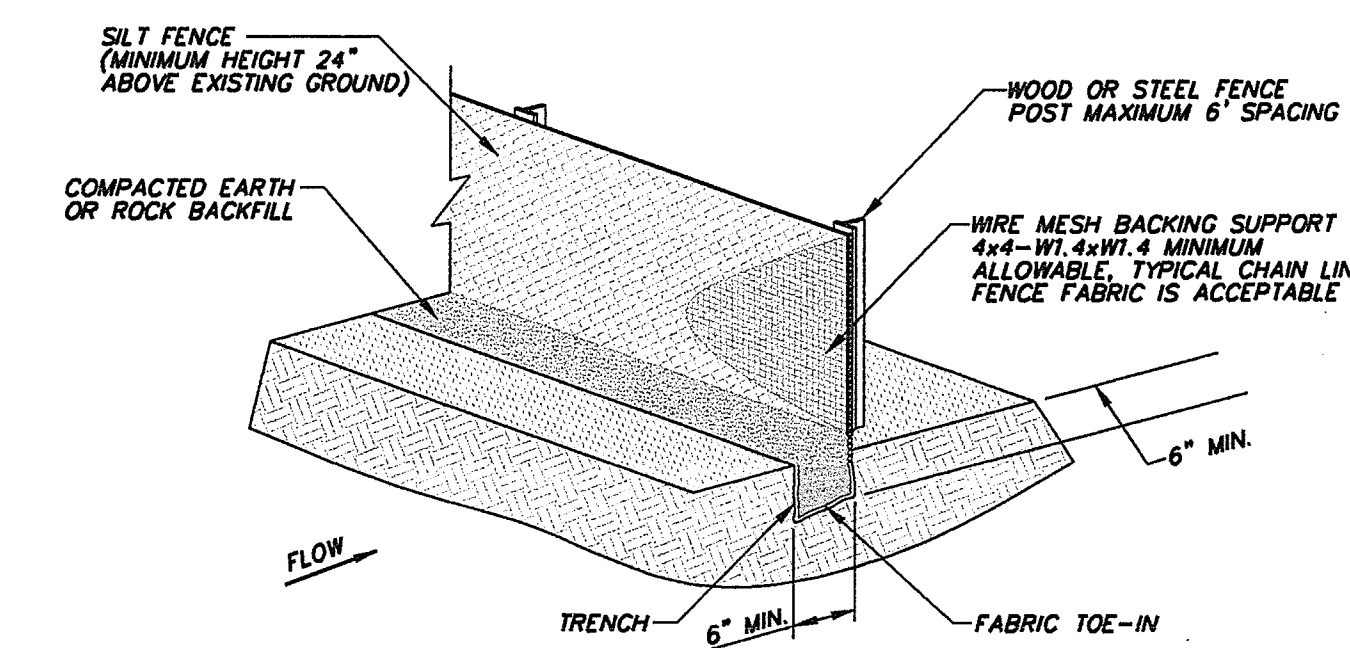

- NOTE:**
1. WOOD OR STEEL POSTS WHICH SUPPORT THE SILT FENCE SHALL BE INSTALLED ON A SLIGHT ANGLE TOWARD THE ANTICIPATED RUNOFF SOURCE. THE POSTS MUST BE EMBEDDED A MINIMUM OF ONE FOOT FOR STEEL OR TWO FEET FOR WOOD.
  2. THE TOE OF THE SILT FENCE SHALL BE TRENCHED IN WITH A SPADE OR MECHANICAL TRENCHER, SO THAT THE DOWNSLOPE FACE OF THE TRENCH IS FLAT AND PERPENDICULAR TO THE LINE OF FLOW. WHERE FENCE CANNOT BE TRENCHED IN (E.G. PAVEMENT), WEIGHT FABRIC FLAP WITH WASHED GRAVEL ON THE UPHILL SIDE TO PREVENT FLOW UNDER FENCE.
  3. THE TRENCH MUST BE A MINIMUM OF 6 INCHES DEEP AND 6 INCHES WIDE TO ALLOW FOR THE SILT FENCE FABRIC TO BE LAID IN THE GROUND AND BACKFILLED WITH COMPACTED MATERIAL.
  4. SILT FENCE SHALL BE SECURELY FASTENED TO EACH STEEL SUPPORT POST OR TO WOVEN WIRE, WHICH IS IN TURN ATTACHED TO THE STEEL SUPPORT POST. THERE SHALL BE A 6 INCH DOUBLE OVERLAP, SECURELY FASTENED WHERE ENDS OF FABRIC MEET.
  5. INSPECTION SHALL BE MADE WEEKLY OR AFTER EACH RAINFALL. REPAIR OR REPLACEMENT SHALL BE MADE PROMPTLY AS NEEDED.
  6. SILT FENCE SHALL BE REMOVED WHEN THE SITE IS COMPLETELY STABILIZED SO AS NOT TO BLOCK OR IMPEDE STORM FLOW OR DRAINAGE.
  7. ACCUMULATED SILT SHALL BE REMOVED WHEN IT REACHED A DEPTH OF 6 INCHES. THE SILT SHALL BE DISPOSED OF AT AN APPROVED SITE AND IN SUCH A MANNER AS TO NOT CONTRIBUTE TO ADDITIONAL SILTATION.
  8. CONTRACTOR SHALL PROVIDE TRIANGULAR SEDIMENT FILTER DIKE WHERE SILT FENCE IS REQUIRED BUT NOT INSTALLABLE.

**SILT FENCE**  
NOT TO SCALE

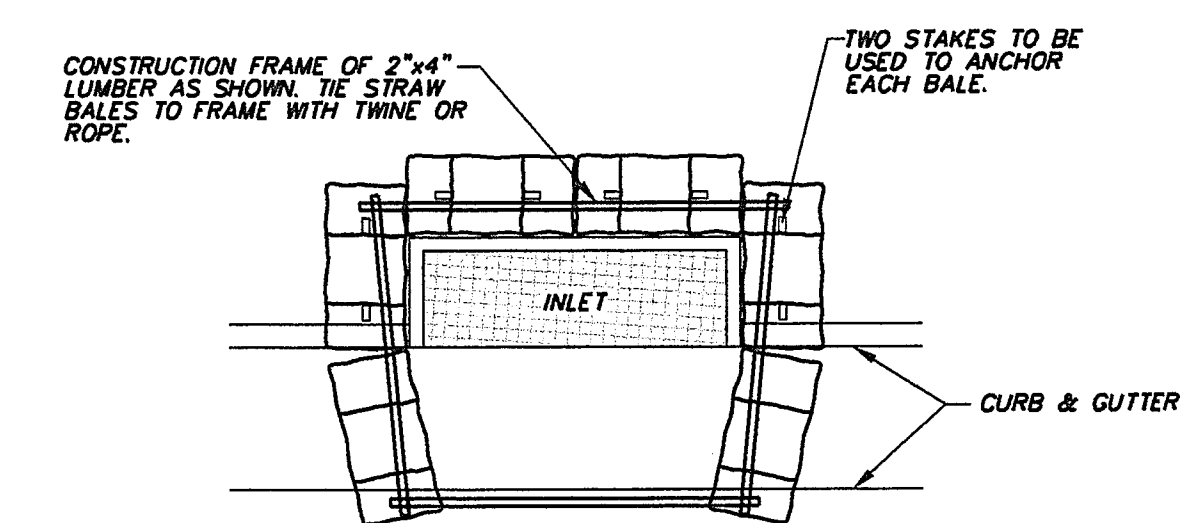

**CURB INLET PROTECTION**  
NOT TO SCALE

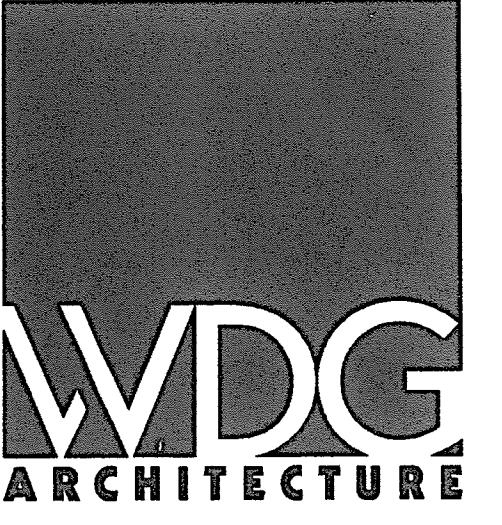

WDG Architecture Dallas, PLLC  
325 North St. Paul Street  
Suite 3800  
Dallas, Texas 75201  
tel 214 969 5311  
fax 214 871 8738

Structural Engineer

Viewtech Structural Engineers, Inc.  
4805 Bellway Drive  
Addison, Texas 75001  
tel 972 661 8187  
fax 972 661 8172

MEP Engineers

Jordan & Skala Engineers, Inc.  
14840 Midway Road  
Suite 350  
Dallas, Texas 75244  
tel 469 385 1616  
fax 469 385 1615

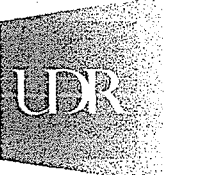

UDR, Inc.  
Three Lincoln Centre  
5430 LBJ Freeway, Suite 1250  
Dallas, Texas 75240



VITRUVIAN PARK  
IN ADDISON

Vitruvian Park Phase I South  
Brookhaven Club Drive  
Addison, Texas

CONSTRUCTION	10/13/08
PERMIT	7/31/08
PRELIM GRADING	6/27/08

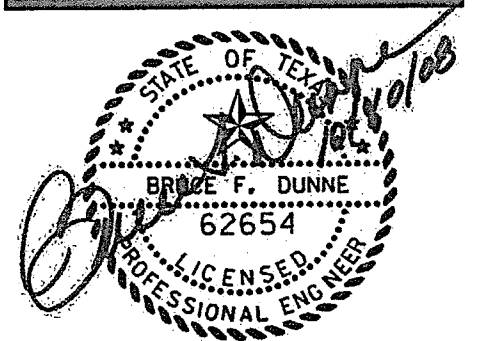

**icon Consulting Engineers, Inc.**  
Civil Engineers - Designers - Planners  
Bicentennial Financial Center  
250 W. Southlake Blvd., Suite 117  
Southlake, TX 76092  
Phone: (817) 552-8210  
Fax: (817) 552-3126

© 2007 WDG Project No: DA07008

**EROSION & SEDIMENT CONTROL DETAILS**

Date: 6/27/08

Scale: As Noted

C7.2