

DISCLAIMER: The use of this standard is governed by the "Texas Engineering Practice Act". No warranty of any kind is made by TxDOT for any purpose whatsoever. TxDOT assumes no responsibility for the conversion of this standard to other formats or for incorrect results or damages resulting from its use.

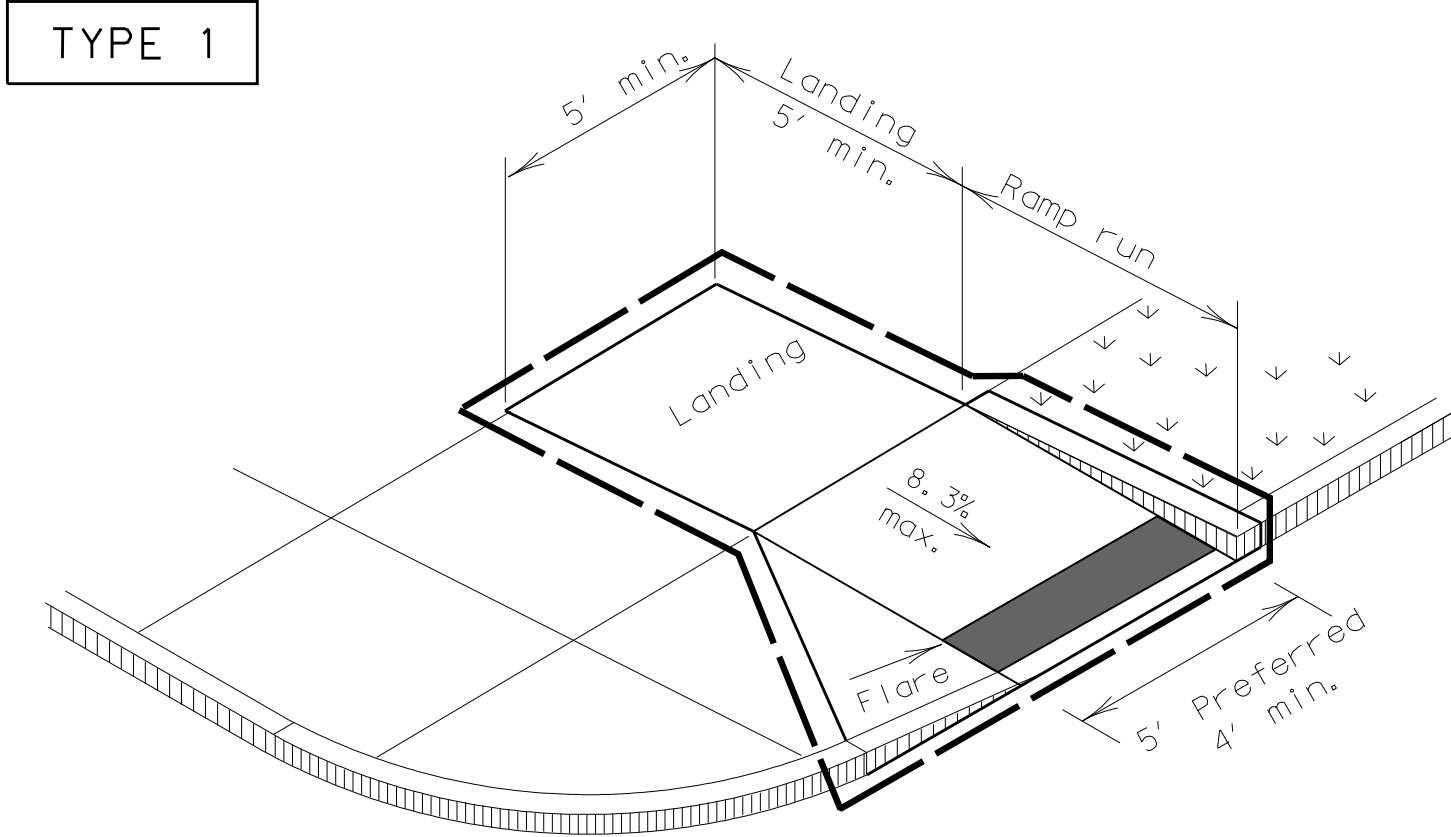

PERPENDICULAR CURB RAMP

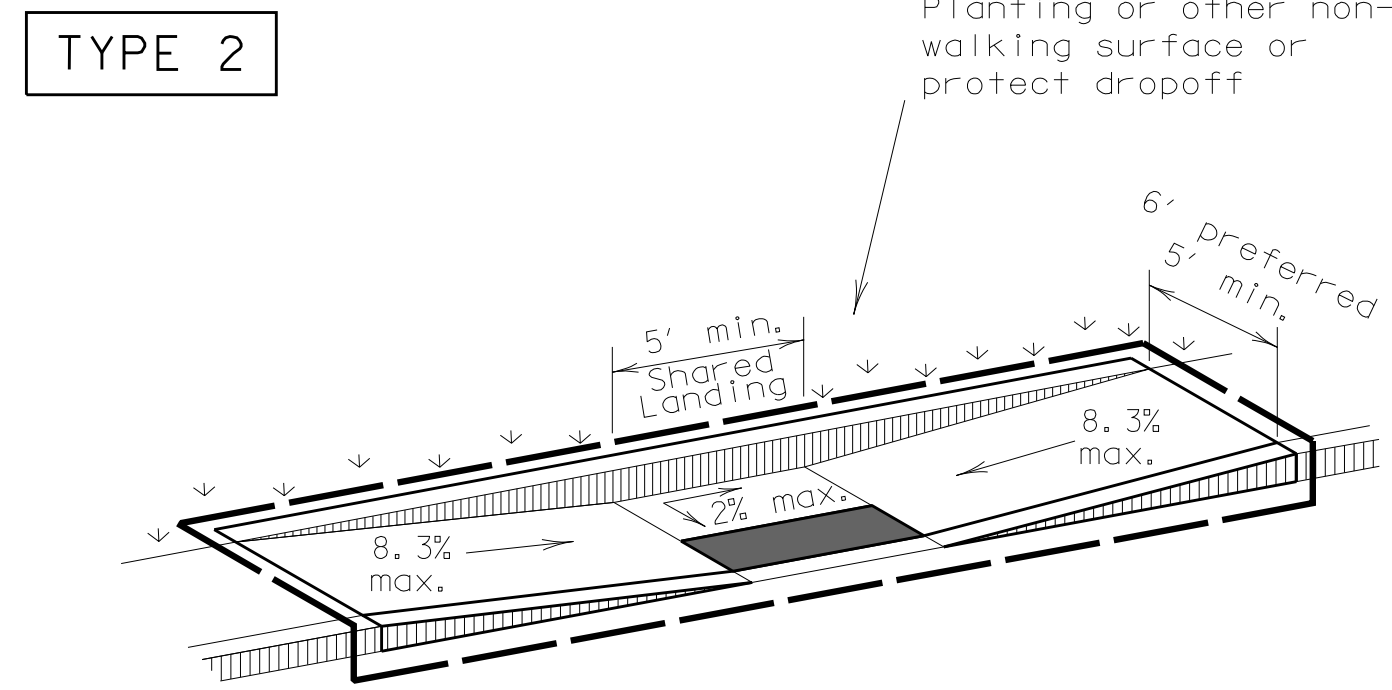

PARALLEL CURB RAMP

(Use only where water will not pond in the landing.)

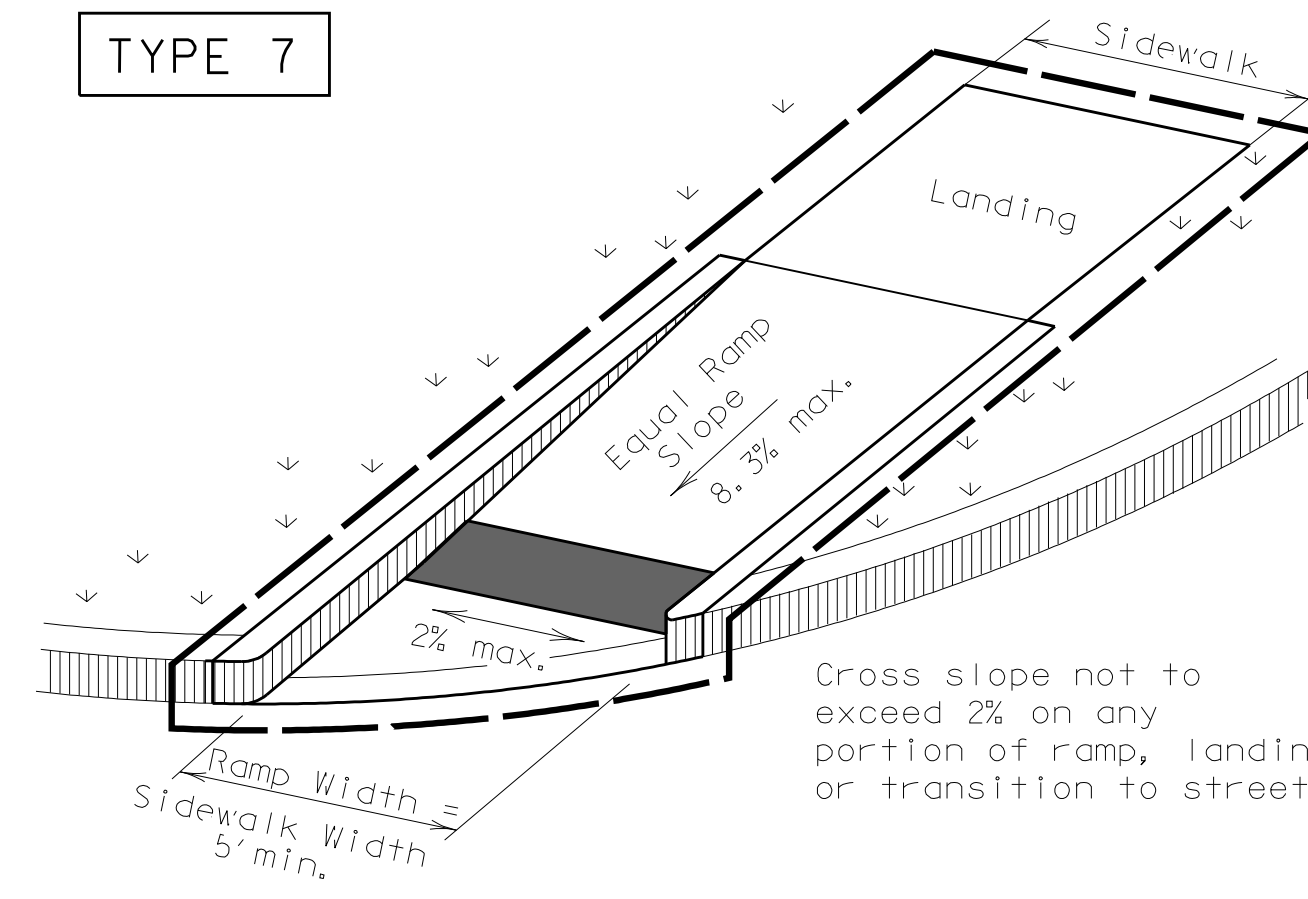

(Sidewalk set back from curb)

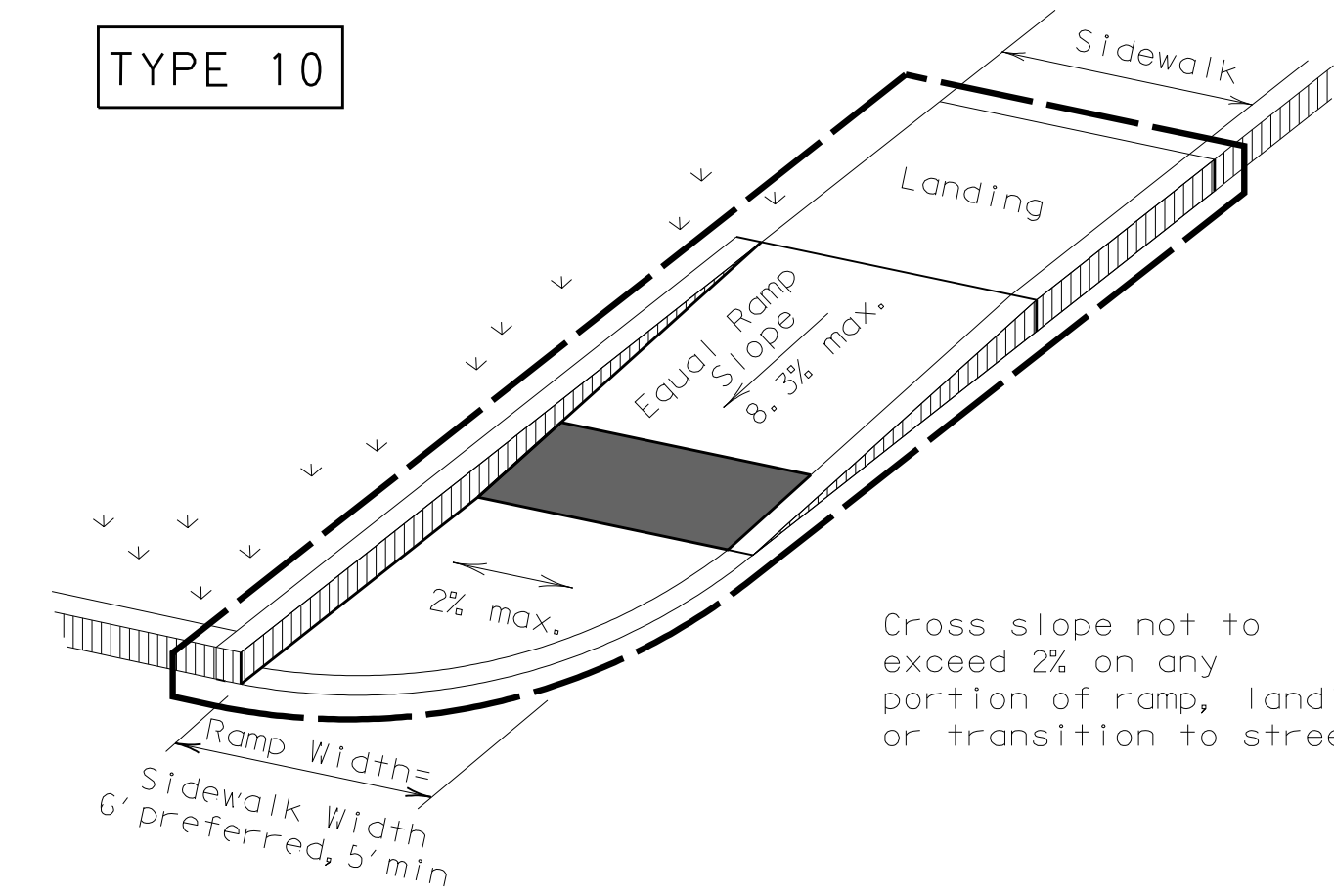

(Sidewalk adjacent to curb)

DIRECTIONAL RAMPS WITHIN RADIUS

Install detectable warning surface at each end of cut-through ramp with minimum 2' smooth surface between. If median is less than 6' wide, eliminate detectable warning surfaces.

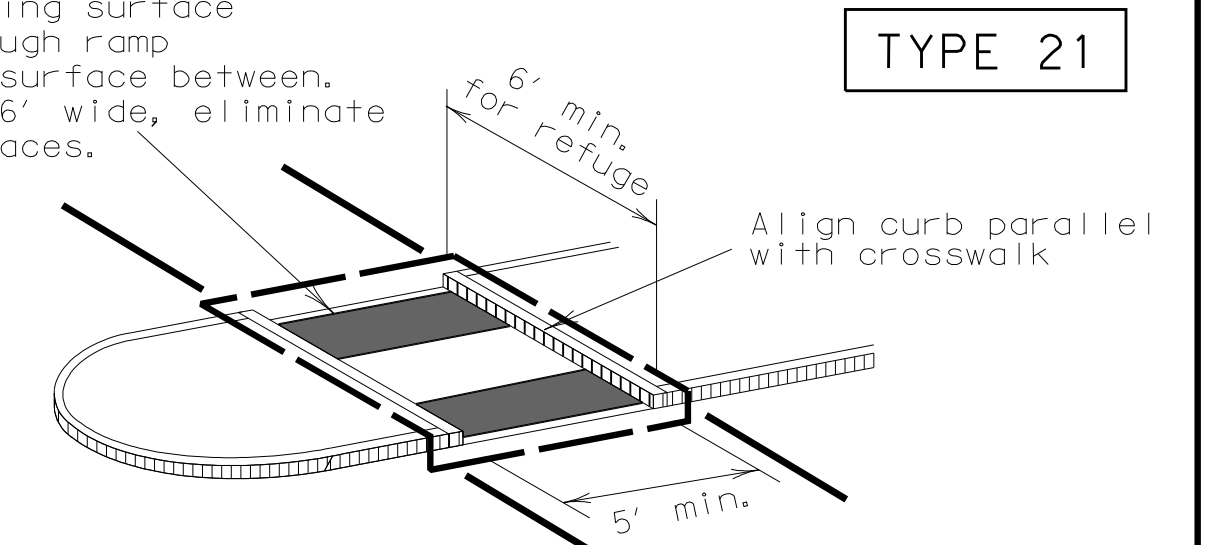

TYPE 21

Curb details are shown elsewhere in the plans.

CURB RAMPS AT MEDIAN ISLANDS

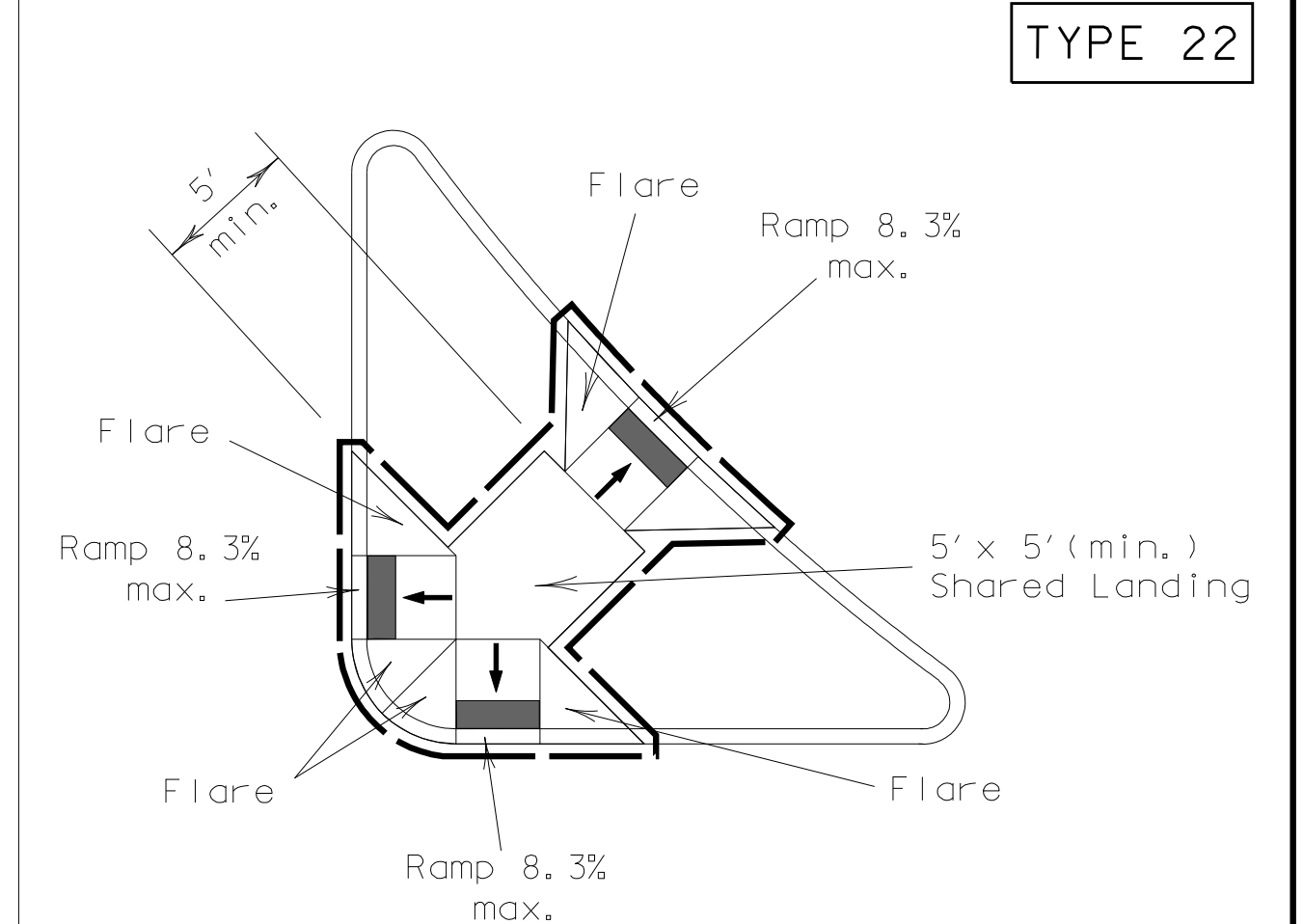

TYPE 22

COMBINATION ISLAND RAMPS

NOTES / LEGEND:

See General Notes on sheet 2 of 4 for more information.

Denotes planting or non-walking surface not part of pedestrian circulation path.

Ramp Limits of Payment

Detectable Warning Surface

SHEET 1 OF 4



Design Division Standard

PEDESTRIAN FACILITIES
CURB RAMPS

PED-12A

FILE: ped12a.dgn	DN: TxDOT	CK: RM	DW: TxDOT	CK: VP
© TxDOT March 2002	CONT	SECT	JOB	HIGHWAY
VP June 13, 2012	DIST	COUNTY	SHEET NO.	
			31	