

**SLOPE DETAIL**  
NO SCALE

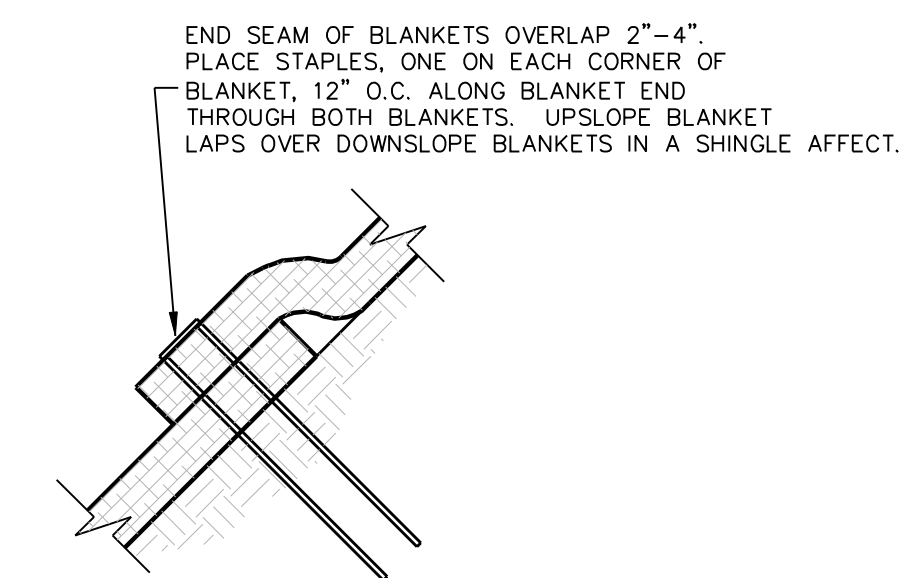

**END ROLL OVERLAP**  
NO SCALE

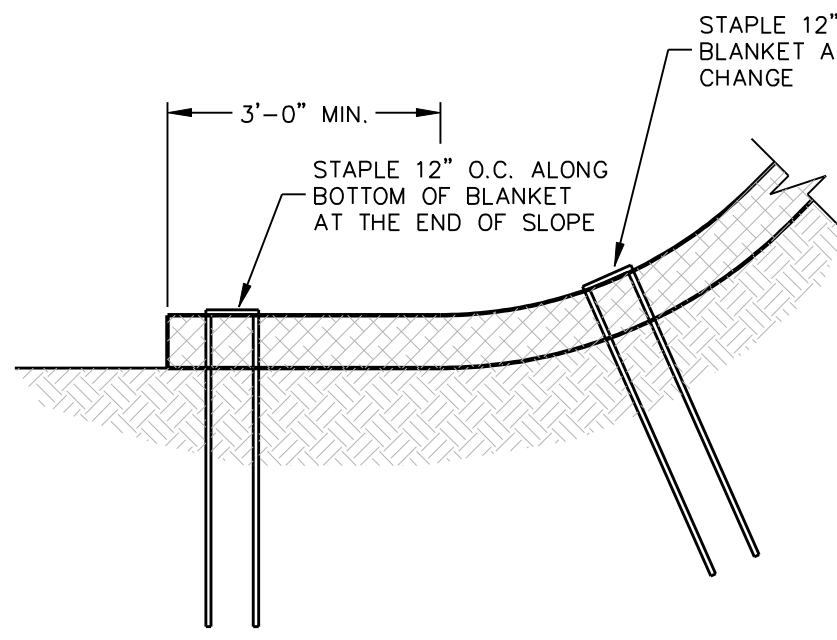

**BOTTOM OF SLOPE TERMINATION**  
NO SCALE

**EROSION CONTROL BLANKET**  
NOT TO SCALE

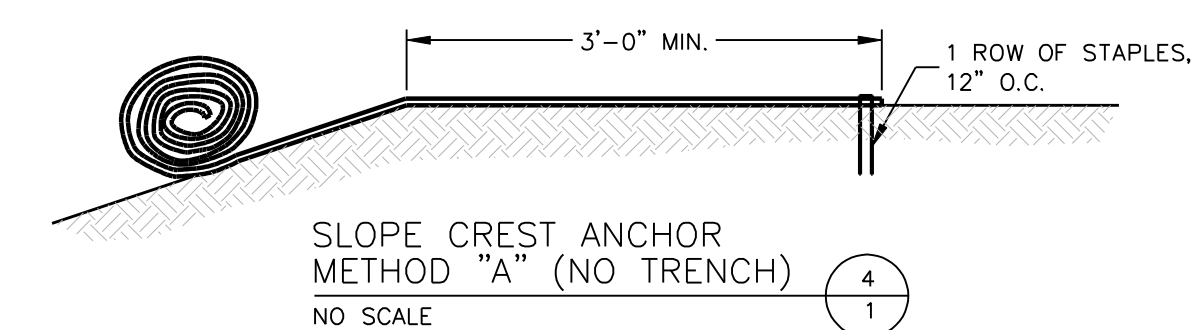

**SLOPE CREST ANCHOR METHOD "A" (NO TRENCH)**  
NO SCALE

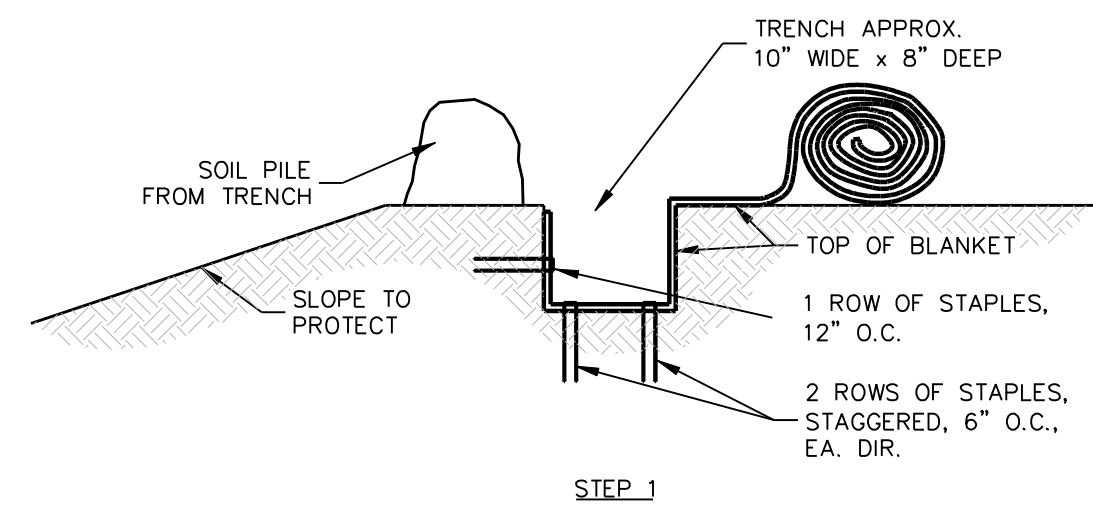

STEP 1

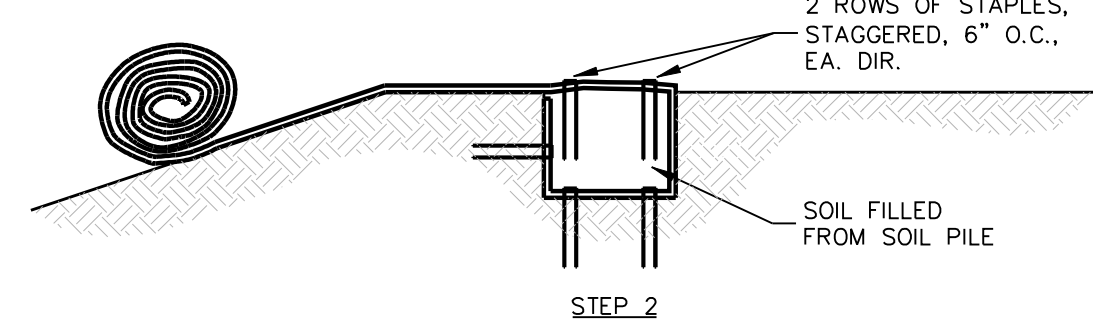

STEP 2

**SLOPE TRENCHING METHOD "B"**  
NO SCALE

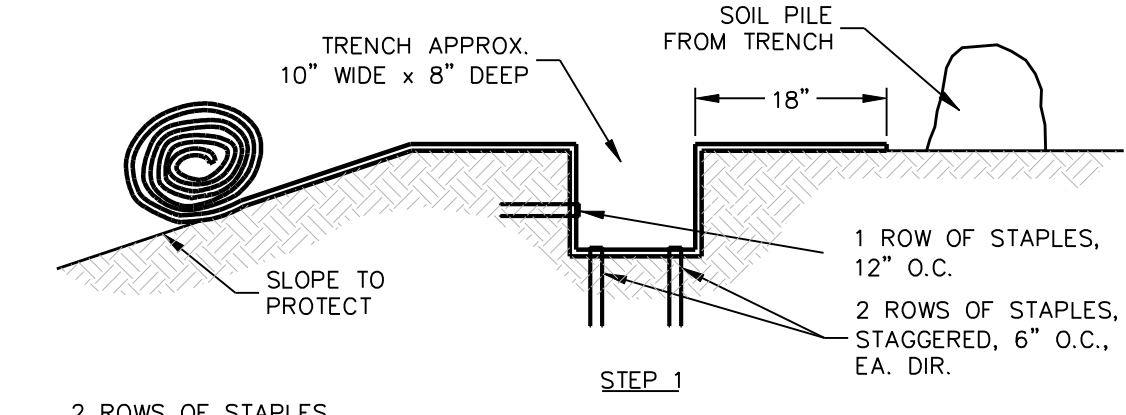

STEP 1

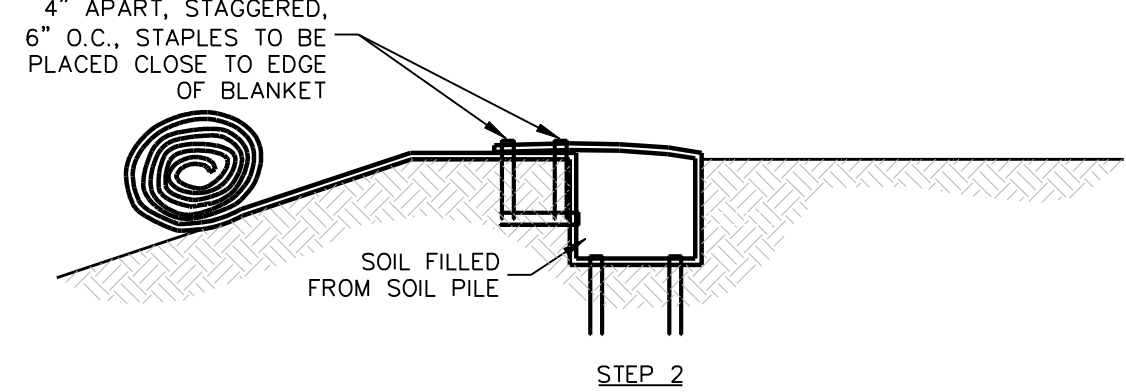

STEP 2

**SLOPE TRENCHING METHOD "C"**  
NO SCALE

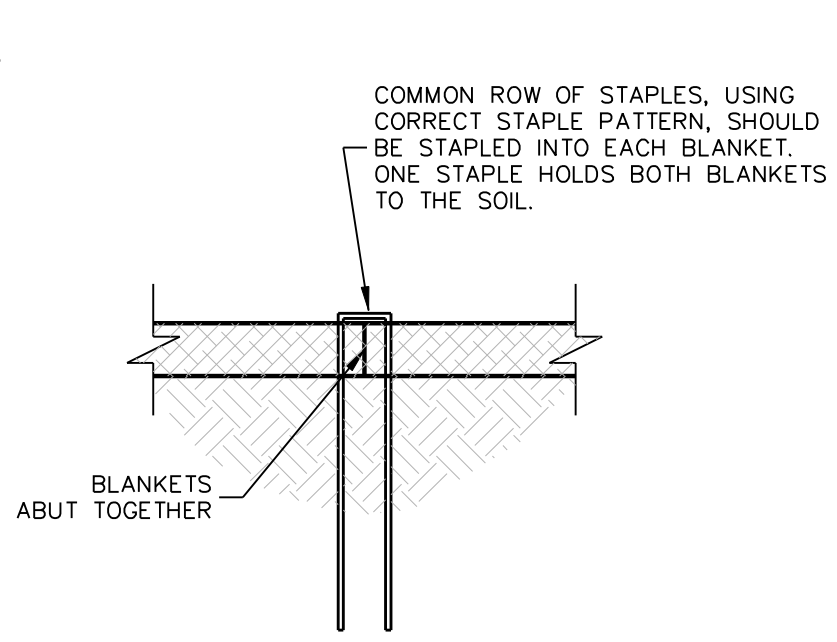

**SIDE SEAM ABUT STAPLE DETAIL**  
NO SCALE

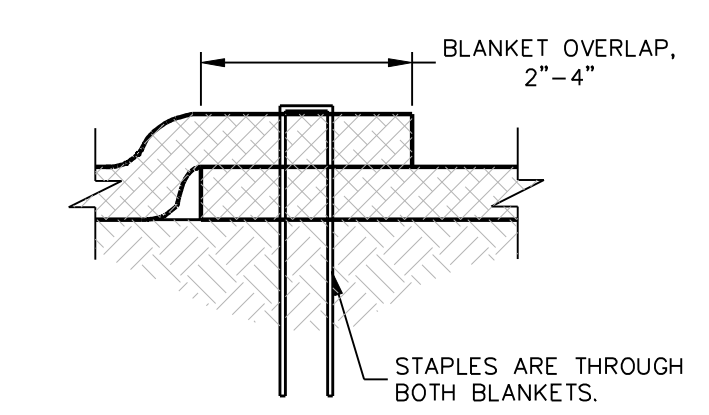

**SIDE SEAM OVERLAP STAPLE DETAIL**  
NO SCALE

- NOTES:**
1. STAPLE PATTERNS ARE DEPENDENT ON SITE CONDITIONS. SEE CURLEX® STAPLE PATTERN GUIDE FOR DETAILS.
  2. E-STAPLE® MAY BE USED IN PLACE OF WIRE STAPLES.
  3. CURLEX® IN NEUTRAL COLOR.

- NOTES: SILT FENCE**
1. Posts which support the silt fence shall be installed on a slight angle toward the anticipated runoff source. The post must be embedded a minimum of 18 inches.
  2. The toe of the silt fence shall be trenched in with a spade or mechanical trencher, so that the downslope face of the trench is flat and perpendicular to the line of flow. Where fence cannot be trenched in (e.g. pavement), weight fabric flap with washed gravel on the uphill side to the trench must be a minimum of 8 inches deep and 8 inches wide to allow for the silt fence fabric to be laid in the ground and backfilled with compacted material.
  3. Silt fence shall be securely fastened to each support post or to woven wire, which is in turn attached to the support post. There shall be a 6 inch double overlap, securely fastened where ends of fabric meet.
  4. Inspection shall be made daily or after each rainfall. Repair or replacement shall be made promptly as needed.
  5. Silt fence shall be removed when the site is completely stabilized so as not to block or impede storm flow or drainage.
  6. Accumulated silt shall be removed when it reached a depth of 3 inches. The silt shall be disposed of at an approved site and in such a manner as to prevent flow under fence not contribute to additional siltation.

4" MIN. STEEL OR WOOD POSTS SPACED AT 5' TO 8' SOFTWOOD POSTS SHALL BE 3" MIN. IN. DIA. OR NOMINAL 2"x4" HARDWOOD POSTS SHALL HAVE A MIN. CROSS SECTION OF 1.5"x1.5" (3.8 cm x 3.8 cm).

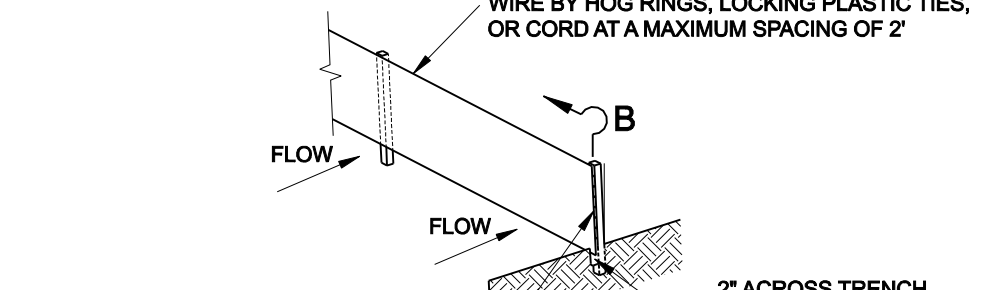

ATTACHED THE WOVEN FABRIC USING EVENLY SPACED STAPLES OR LOCKING PLASTIC TIES FOR WOODEN POSTS AT A MAX. SPACING OF 6". USE LOCKING PLASTIC TIES OR SEWN VERTICAL POCKETS FOR STEEL POSTS AT SAME SPACING.

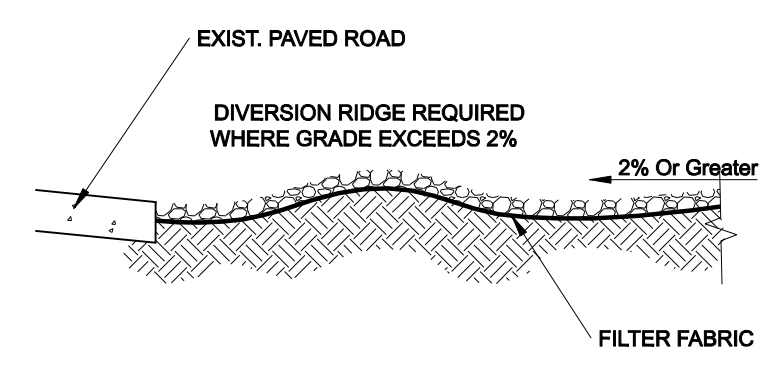

**SECTION B**

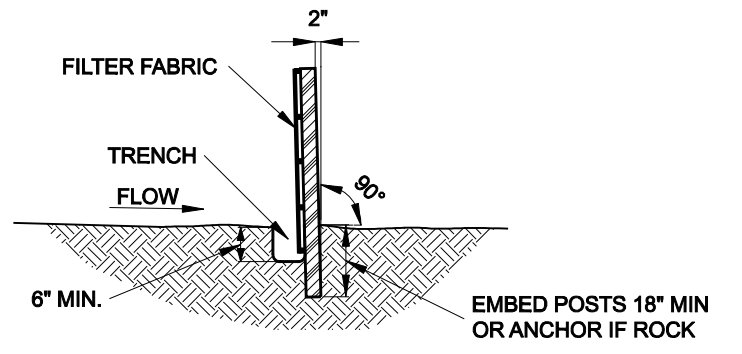

**SECTION A**

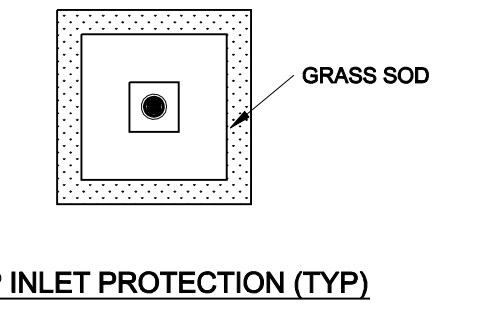

**DROP INLET PROTECTION (TYP)**

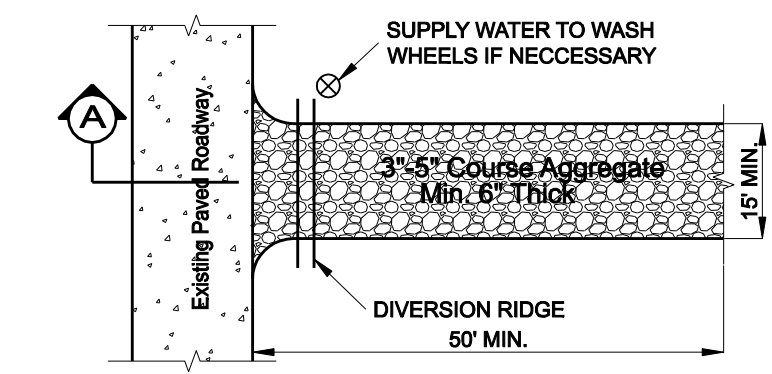

**PLAN**

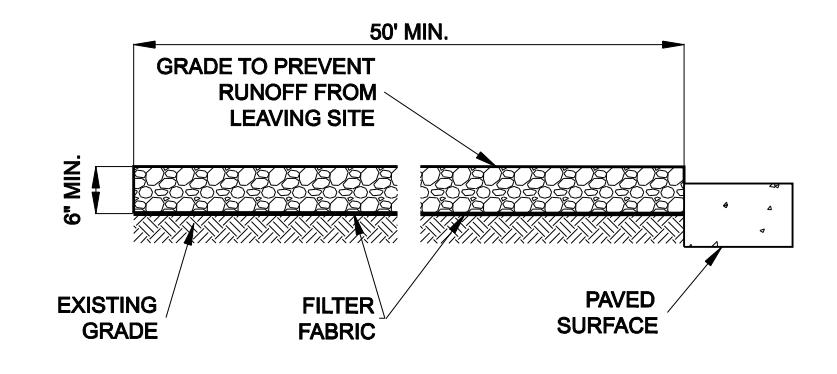

**TEMPORARY STONE CONSTRUCTION ENTRANCE / EXIT**

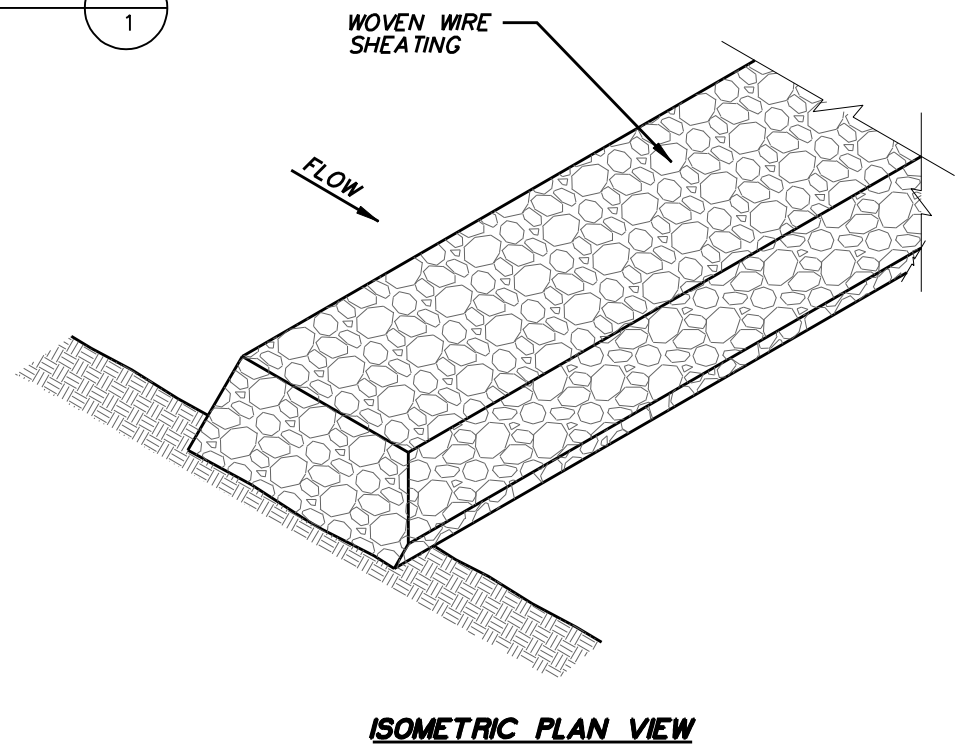

**ISOMETRIC PLAN VIEW**

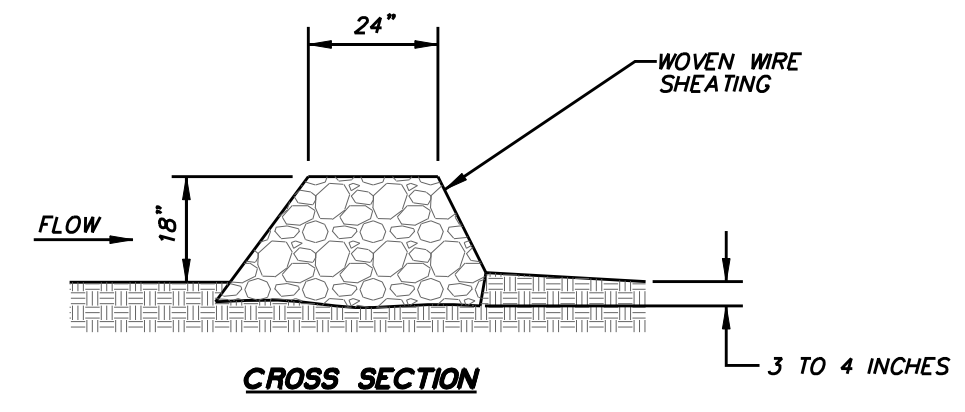

**CROSS SECTION**

- NOTES:**
1. USE OPEN GRADED ROCK 4-8 INCHES IN DIAMETER FOR STREAM FLOW CONDITION. USE OPEN GRADED ROCK 3-5 INCHES IN DIAMETER FOR OTHER CONDITIONS.
  2. THE ROCK DAM SHALL BE SECURED WITH A WOVEN WIRE SHEATHING HAVING A MAXIMUM OPENING OF 1 INCH AND A MINIMUM WIRE SIZE OF 20 GAUGE AND SHALL BE BURIED IN A TRENCH APPROXIMATELY 3 TO 4 INCHES DEEP.
  3. THE ROCK DAM SHALL BE INSPECTED WEEKLY OR AFTER EACH RAIN EVENT AND SHALL BE REPLACED WHEN THE STRUCTURE CEASES TO FUNCTION AS INTENDED DUE TO SILT ACCUMULATION AMONG THE ROCKS, WASHOUT, CONSTRUCTION TRAFFIC DAMAGE, ETC.
  4. WHEN SILT REACHES DEPTH EQUAL TO ONE-THIRD OF THE HEIGHT OF THE DAM OR ONE FOOT, WHICHEVER IS LESS, THE SILT SHALL BE REMOVED AND DISPOSED OF PROPERLY.
  5. WHEN THE SITE IS COMPLETELY STABILIZED, THE DAM AND ACCUMULATED SILT SHALL BE REMOVED AND DISPOSED OF IN AN APPROVED MANNER.

**ROCK CHECK DAM**  
NOT TO SCALE

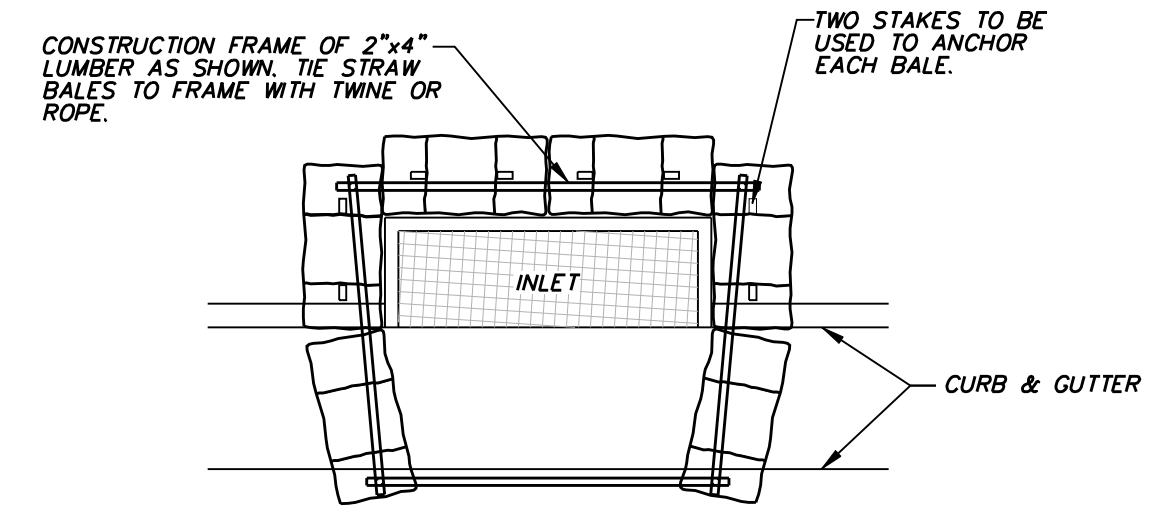

**CURB INLET PROTECTION**  
NOT TO SCALE

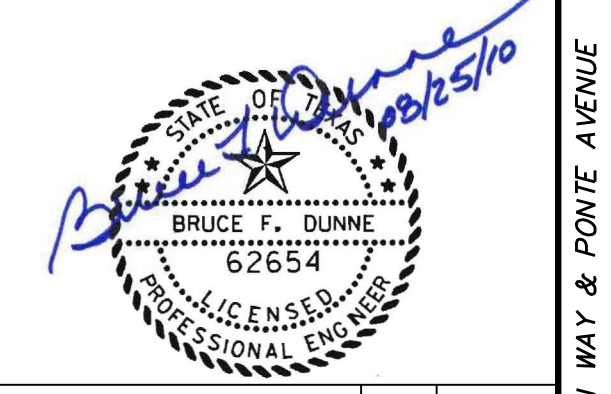

NO.	REVISION	BY	DATE

**Addison!** TOWN OF ADDISON  
DALLAS COUNTY, TEXAS

PAVING, DRAINAGE & UTILITY IMPROVEMENTS  
VITRUVIAN WAY & PONTE AVENUE

**EROSION & SEDIMENT CONTROL DETAILS**

**icon** Consulting Engineers, Inc.  
Civil Engineers - Designers - Planners

PROJECT	DESIGN	DRAWN	DATE	FILE	SHEET
5029-01	ICE	ICE	MAY 7 2009	PW# 2009-01	90

PAVING, DRAINAGE, & UTILITY IMPROVEMENTS - VITRUVIAN WAY & PONTE AVENUE