

ANCHOR BOLT DETAILS

- NOTES:
1. Abutment dimensions and anchor rod locations are to be coordinated with bridge manufacturer prior to construction. Abutment dimensions shown are per detail provided by CONTECH for Keystone Pedestrian Truss Bridge.
  2. Anchor Rods and Washers to be subsidiary to the concrete Abutment.

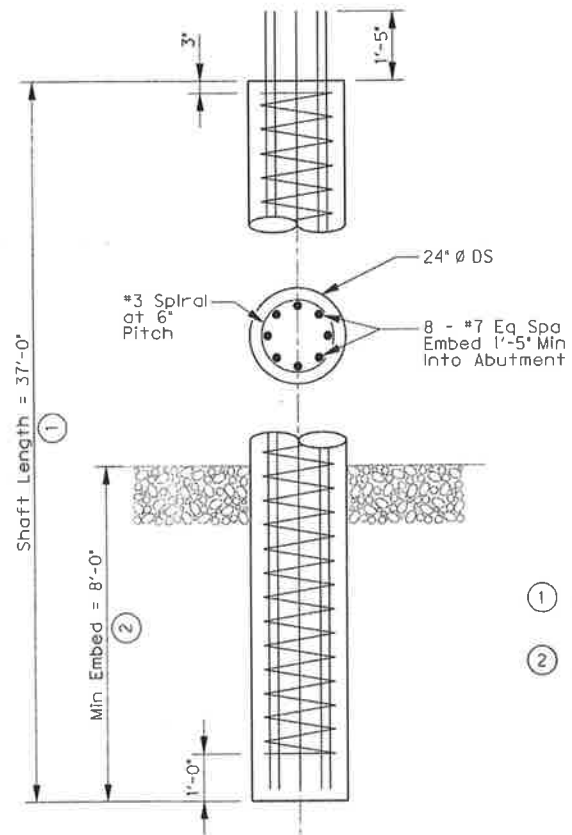

04-29-10  
 THE SEAL APPEARING ON THIS DOCUMENT WAS AUTHORIZED BY ERIC S. CHRISTIANSEN, P.E. #85412 ON 04-29-2010. ALTERATION OF A SEALED DOCUMENT WITHOUT PRIOR NOTIFICATION TO THE RESPONSIBLE ENGINEER IS AN OFFENSE UNDER THE TEXAS ENGINEERING PRACTICE ACT. THE RECORD COPY OF THIS DRAWING IS ON FILE AT THE OFFICES OF HALFF ASSOCIATES, 1201 NORTH BOWSER ROAD, RICHARDSON, TEXAS, 75081. TDP# FPM 17-312.

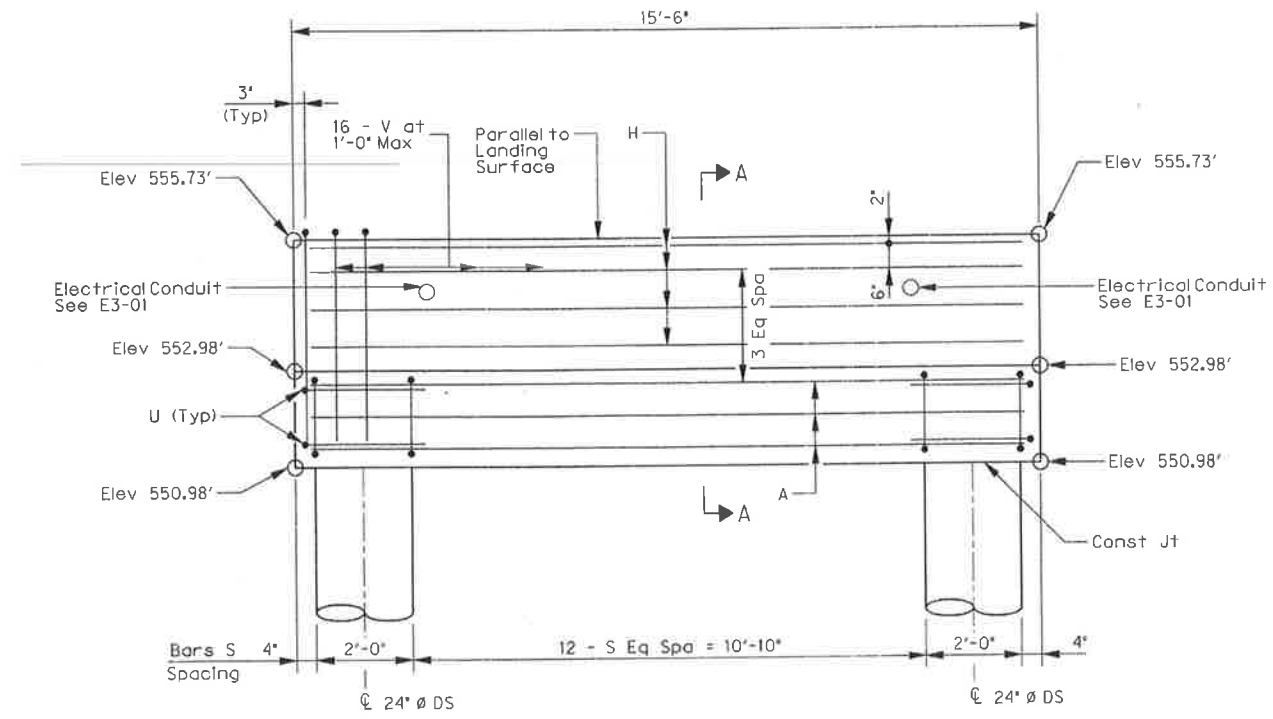

- 1 Length of Drilled Shafts for Contractor's Information only.
- 2 Drill Shafts to the depth shown or deeper, as necessary, to Penetrate Gray Shale to Min Embed.

NO.		REVISION		BY		DATE	
<b>TOWN OF ADDISON</b> DALLAS COUNTY, TEXAS							
<b>VITRUVIAN PARK BRIDGES</b> SOUTHERN PEDESTRIAN BRIDGE							
<b>ABUTMENT PLAN</b> <b>ELEVATION AND DETAILS</b>							
<b>HALFF</b>		1201 NORTH BOWSER ROAD, RICHARDSON, TEXAS 75081-2276 TEL (214) 348-9200 FAX (214) 738-0086					
PROJECT	DESIGN	DRAWN	DATE	FILE	SHEET		
27379	ESC	AHH	APRIL 2010	-	S3-03		