

SECTION A-A (CAP)  
SCALE: 1/2" = 1'-0"

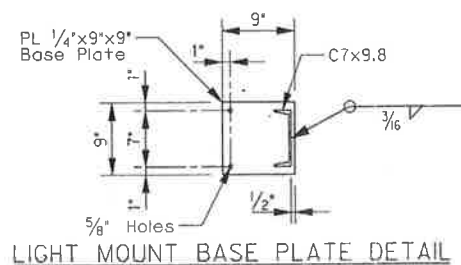

LIGHT MOUNT BASE PLATE DETAIL

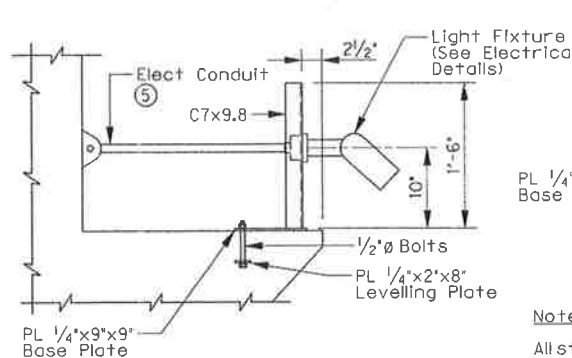

LIGHT MOUNTING DETAIL  
SCALE: 1" = 1'-0"

Notes:  
All steel components shall be galvanized.  
Two light mounting supports shall be located as follows on both abutments:  
centered between Bm Nos 2 and 3  
centered between Bm Nos 5 and 6

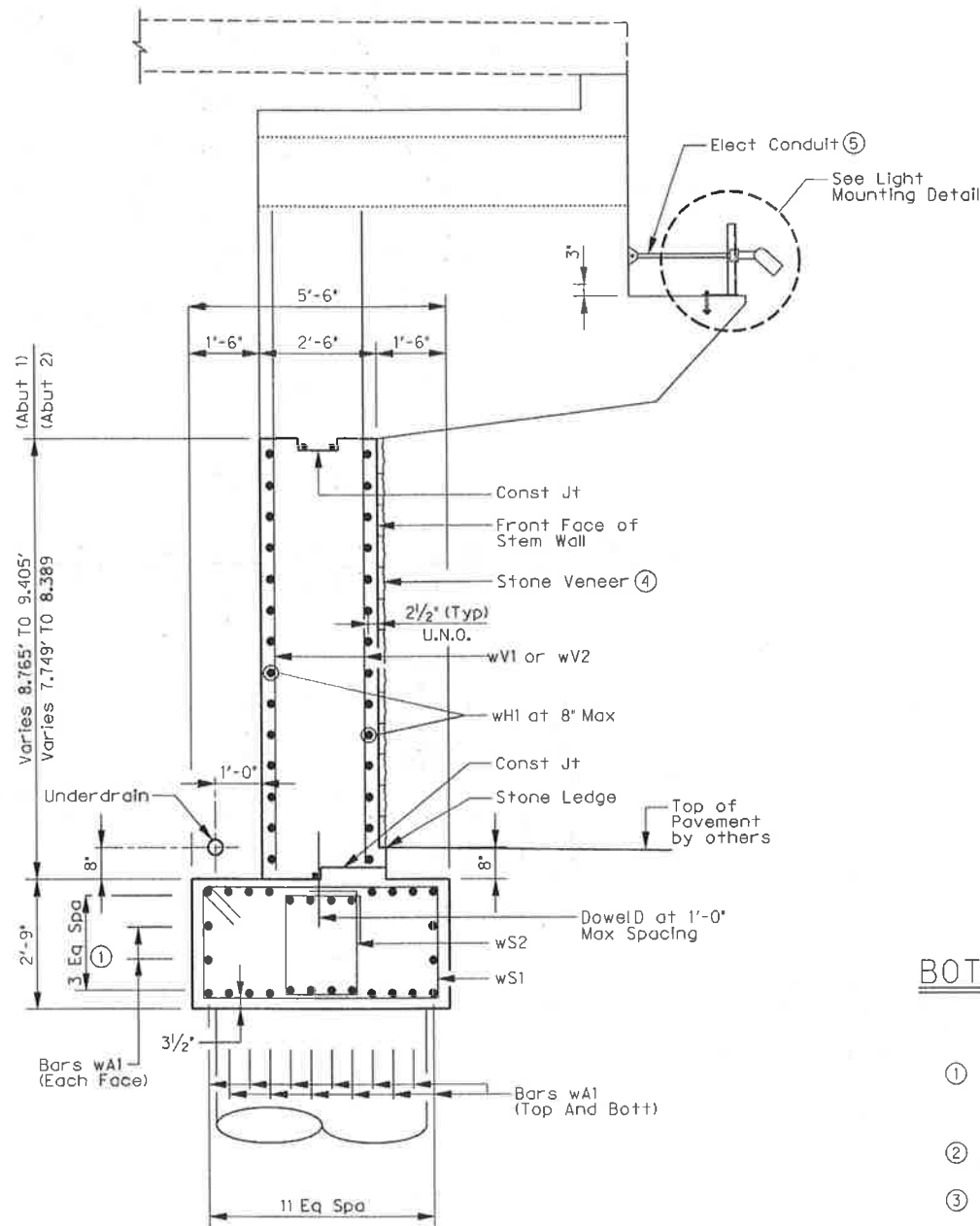

SECTION A-A (STEM WALL & FOOTING)  
SCALE: 1/2" = 1'-0"

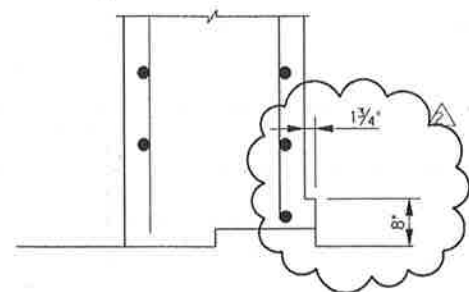

STONE LEDGE DETAIL AT CAP  
SCALE: NTS

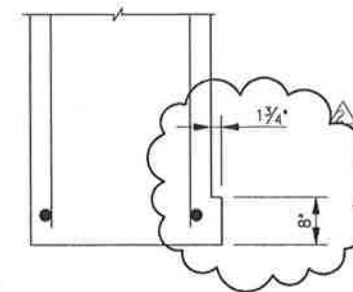

STONE LEDGE DETAIL OFF OF CAP  
SCALE: NTS

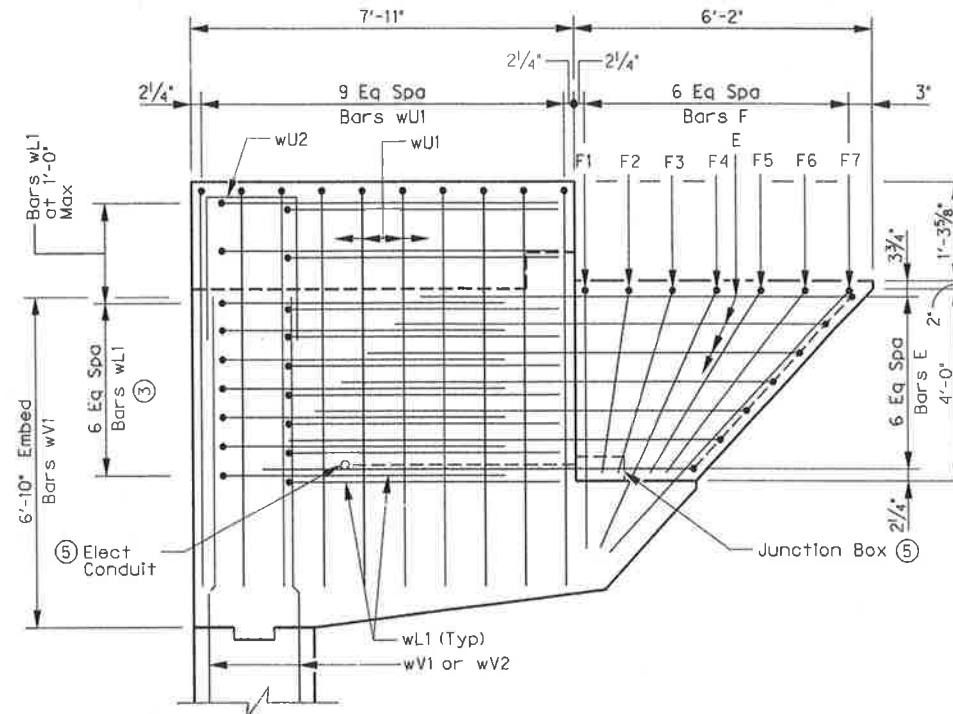

MASK WALL DETAIL  
SCALE: 1/2" = 1'-0"

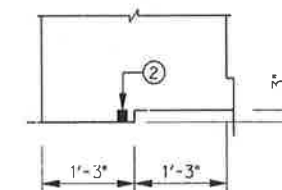

BOTTOM CONST JT DETAIL  
SCALE: NTS

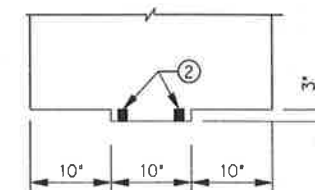

TOP CONST JT DETAIL  
SCALE: NTS

- Adjust top and bottom rows of Bars wA1 to allow for embedment of wA2 and wA3 from support wall and wingwall footings.
- Greenstreak 1" x 3/4" Lockstop waterstop or approved equal
- Lap Bars wL1 with Bars E where possible.
- See landscape architecture drawings for stone veneer details.
- See electrical drawings for details.



THE SEAL APPEARING ON THIS DOCUMENT WAS AUTHORIZED BY ERIC S. CHRISTENSEN, P.E. #5412 ON 05-19-2010. ALTERATION OF A SEALED DOCUMENT WITHOUT PROPER NOTIFICATION TO THE RESPONSIBLE ENGINEER IS AN OFFENSE UNDER THE TEXAS ENGINEERING PRACTICE ACT. THE RECORD COPY OF THIS DRAWING IS ON FILE AT THE OFFICES OF HALFF ASSOCIATES, 1201 NORTH BOWSER ROAD, RICHARDSON, TEXAS, 75081, PHONE FROM 972-312.

Addendum #2		ESC	05/19/10
REVISION		BY	DATE
TOWN OF ADDISON DALLAS COUNTY, TEXAS VITRUVIAN PARK BRIDGES PONTE AVENUE			
ABUTMENT DETAILS - SECTIONS			
1201 NORTH BOWSER ROAD, RICHARDSON, TEXAS 75081-2275 TEL (214) 345-0200 FAX (214) 739-0096			
PROJECT	DESIGN	DRAWN	DATE
27379	ESC	AHH	APRIL 2010
FILE	SHEET		
-	S1-07		