

BARS E

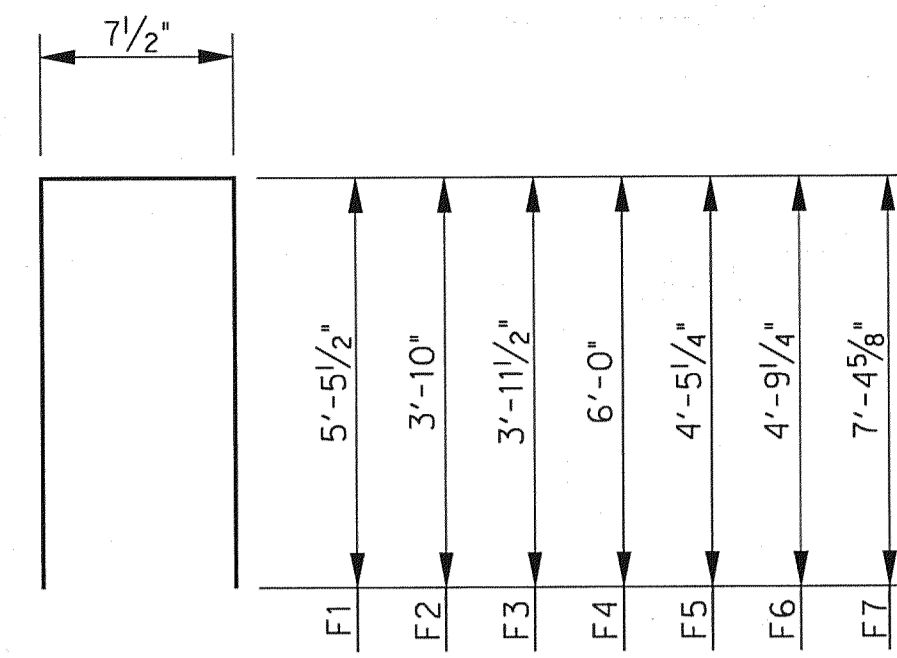

BARS F

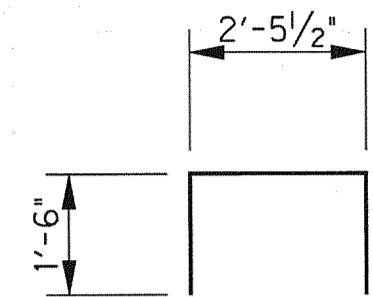

BARS sU

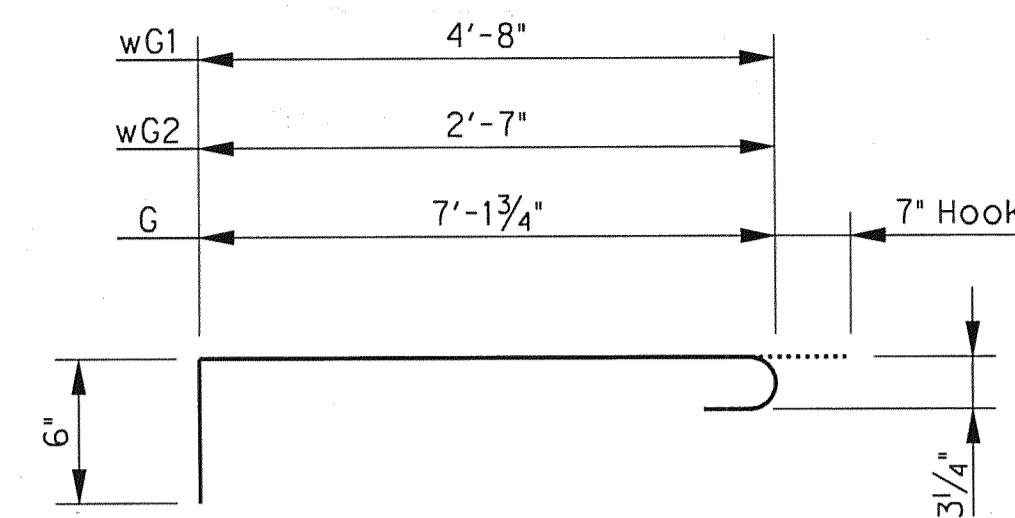

BARS G & wG

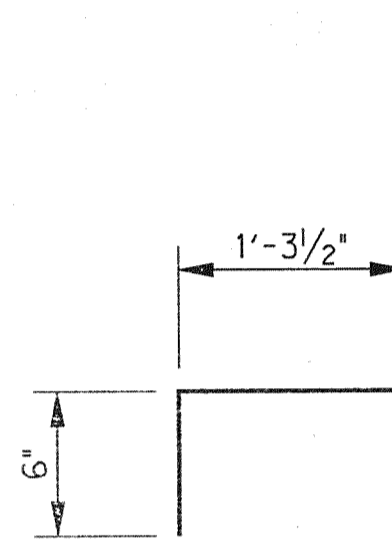

BARS wC

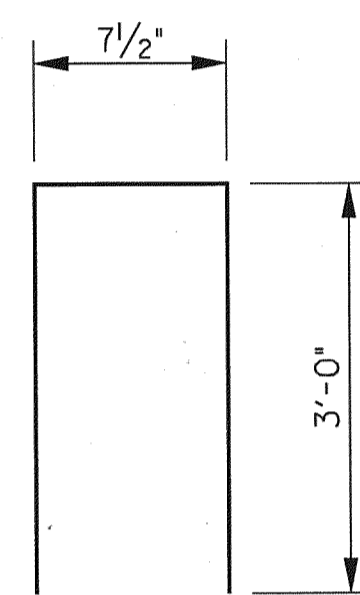

BARS V

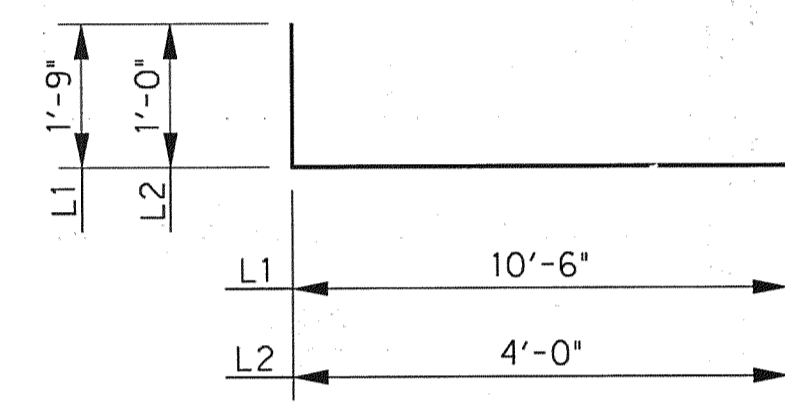

BARS L

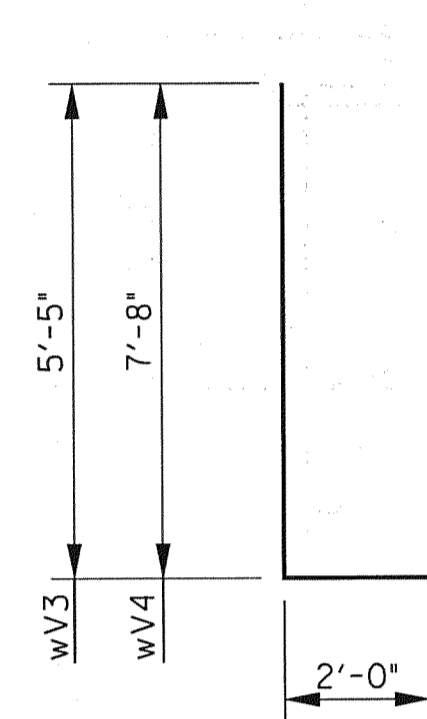

BARS wV3 & wV4

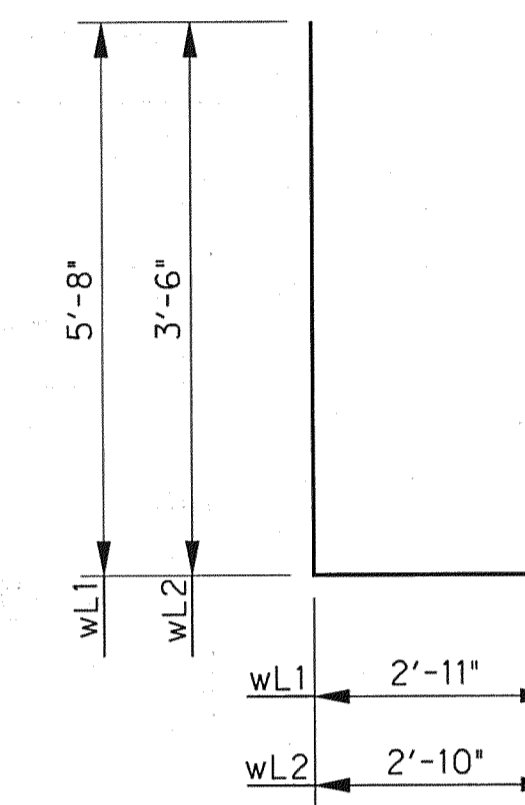

BARS wL

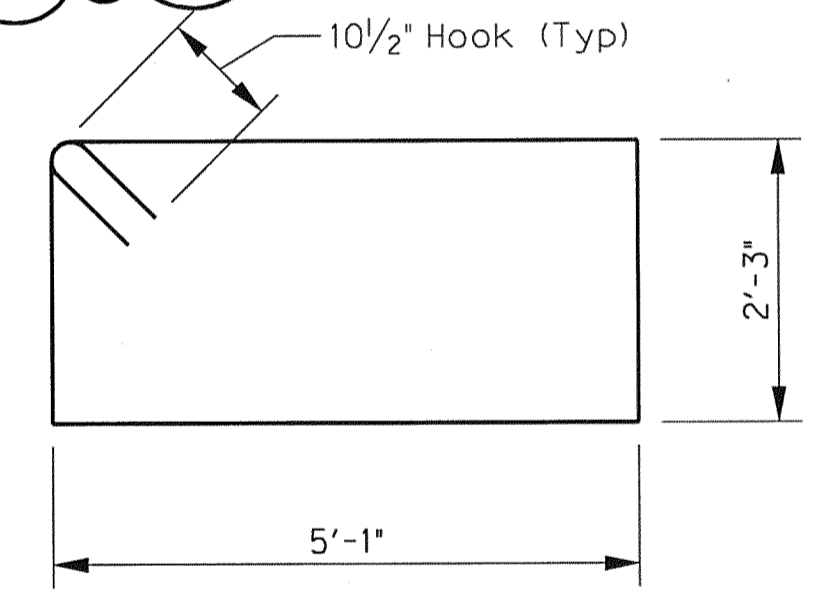
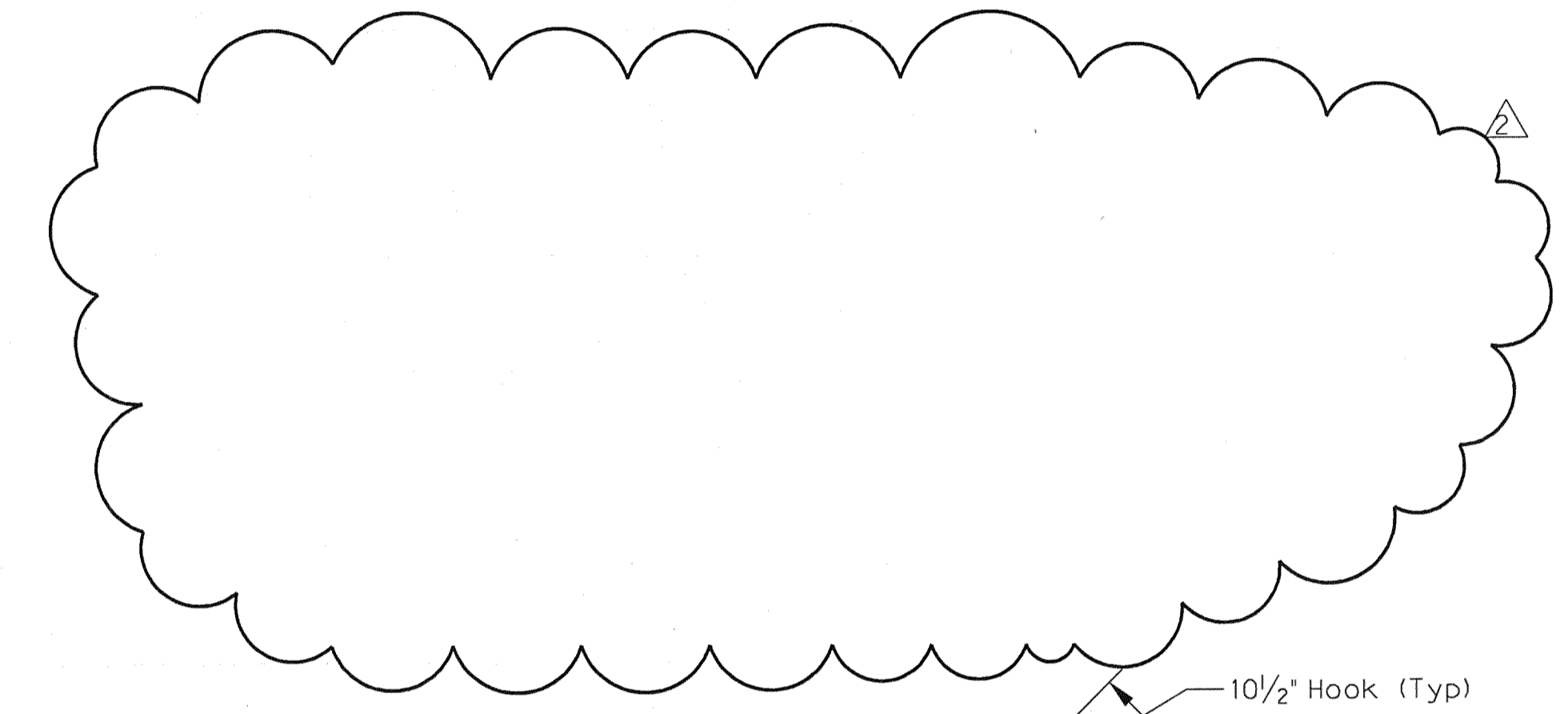

BARS wS1

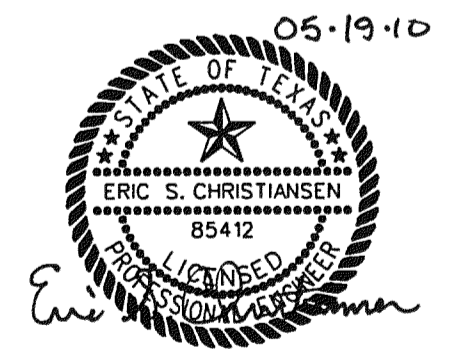

THE SEAL APPEARING ON THIS DOCUMENT WAS AUTHORIZED BY ERIC S. CHRISTIANSEN, P.E. #85412 ON 05-19-2010. ALTERATION OF A SEALED DOCUMENT WITHOUT PROPER NOTIFICATION TO THE RESPONSIBLE ENGINEER IS AN OFFENSE UNDER THE TEXAS ENGINEERING PRACTICES ACT. THE RECORD COPY OF THIS DRAWING IS ON FILE AT THE OFFICES OF HALFF ASSOCIATES, 1201 NORTH BOWSER ROAD, RICHARDSON, TEXAS, 75081. TYPE FIRM #0-312.

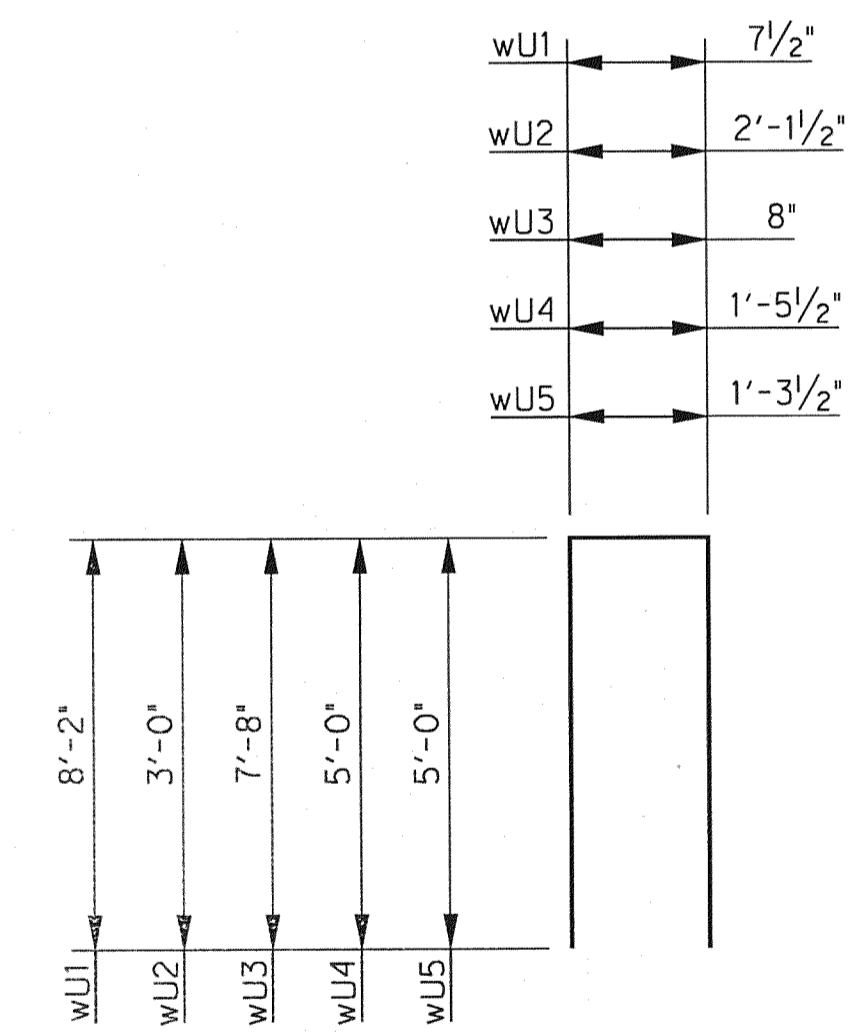

BARS wU

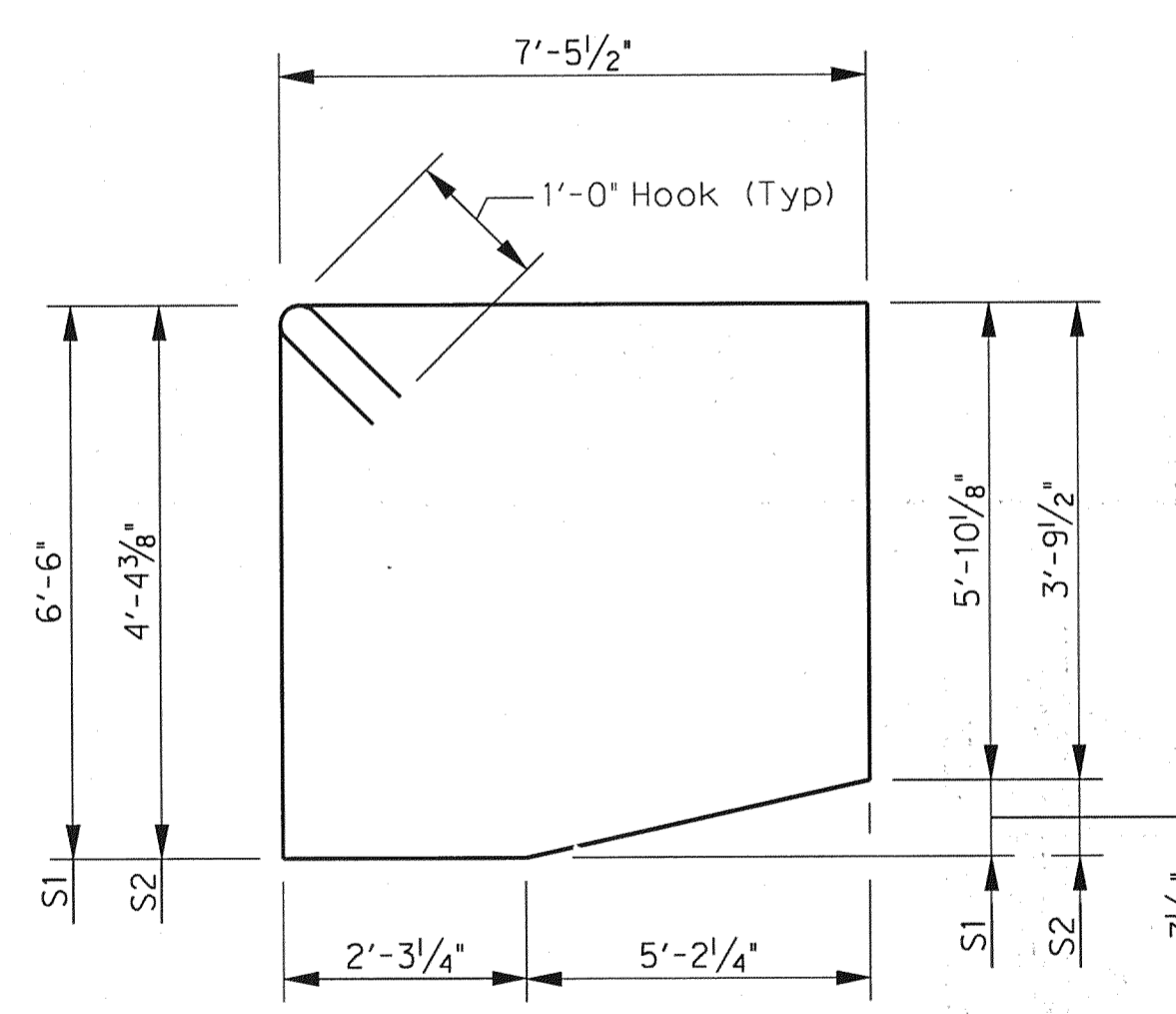

BARS S

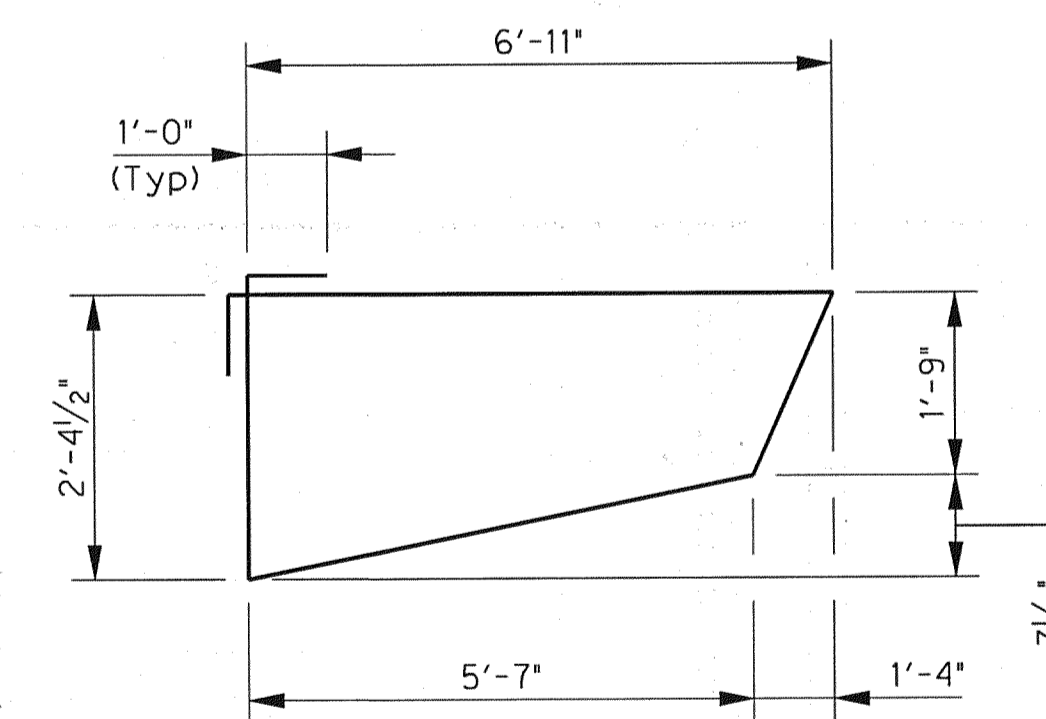

BARS M

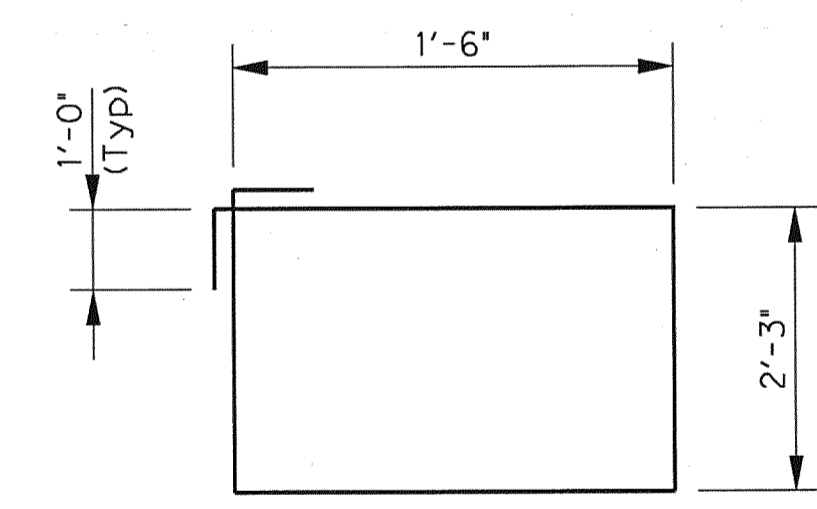

BARS wS2

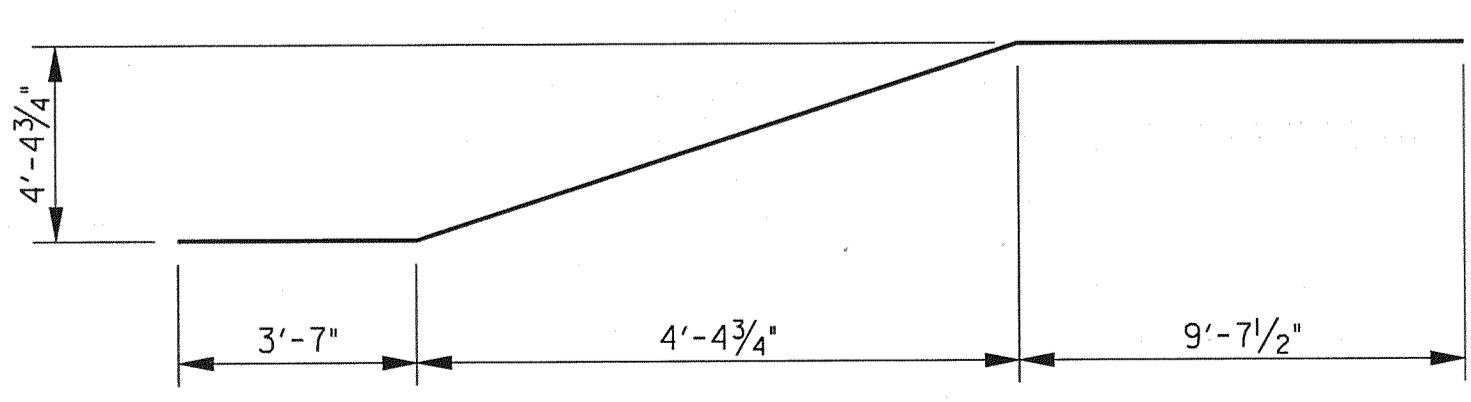

BARS wZ

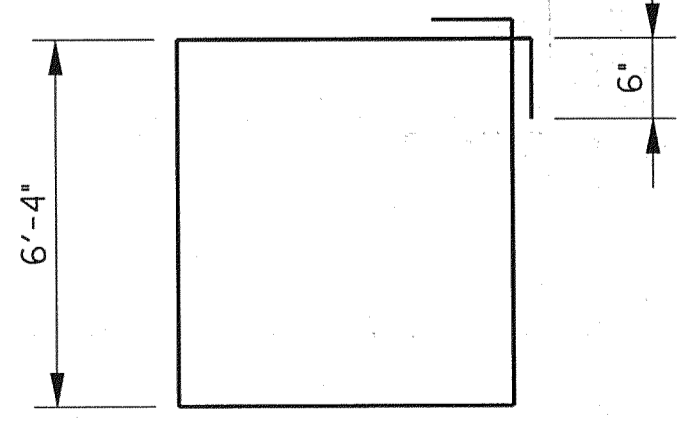

BARS eS

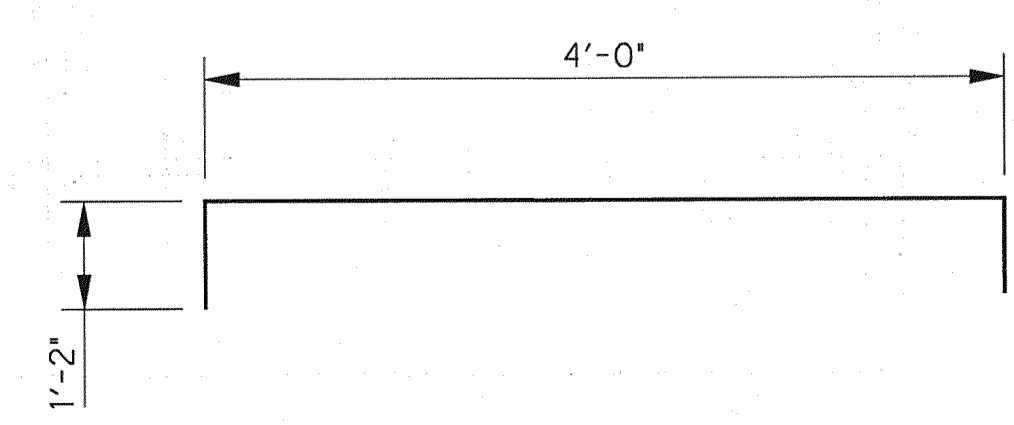

BARS eH1

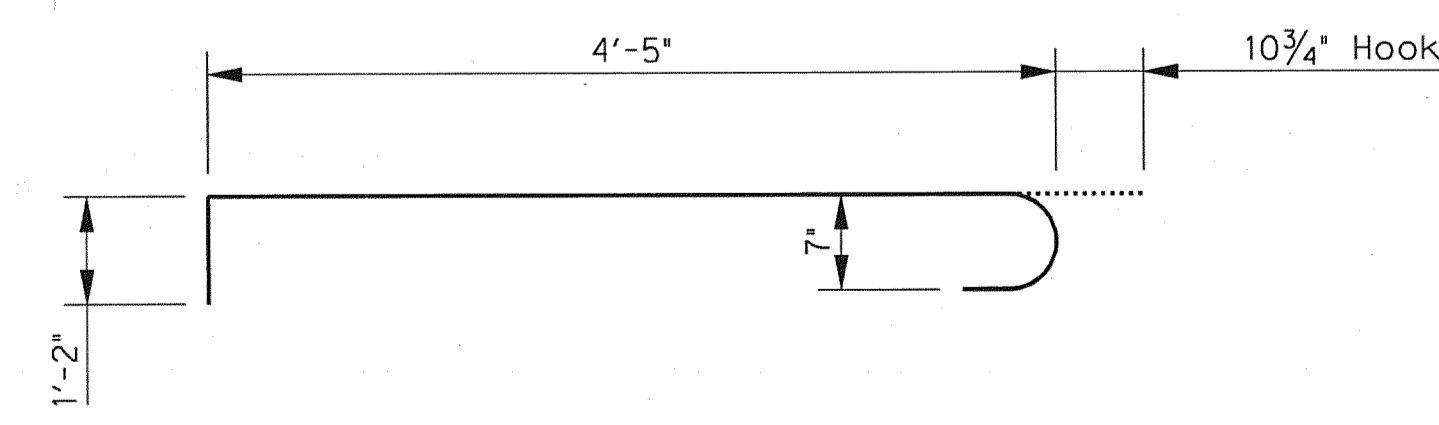

BARS eH2

Addendum #2		ESC	05/19/10
NO.	REVISION	BY	DATE
TOWN OF ADDISON DALLAS COUNTY, TEXAS			
VITRUVIAN PARK BRIDGES PONTE AVENUE			
<b>ABUTMENT DETAILS - BAR BENDING DIAGRAMS</b>			
		1201 NORTH BOWSER ROAD, RICHARDSON, TEXAS 75081-2275 TEL (214) 346-6200 FAX (214) 739-0095	
PROJECT	DESIGN	DRAWN	DATE
27379	ESC	AHH	APRIL 2010
FILE	SHEET		
-	S1-13		