

DISCLAIMER: The use of this standard is governed by the "Texas Engineering Practice Act". No warranty of any kind is made by TxDOT for any purpose whatsoever. TxDOT assumes no responsibility for the conversion of this standard to other formats or for incorrect results or damages resulting from its use.

LEVELS DISPLAYED
PATH:

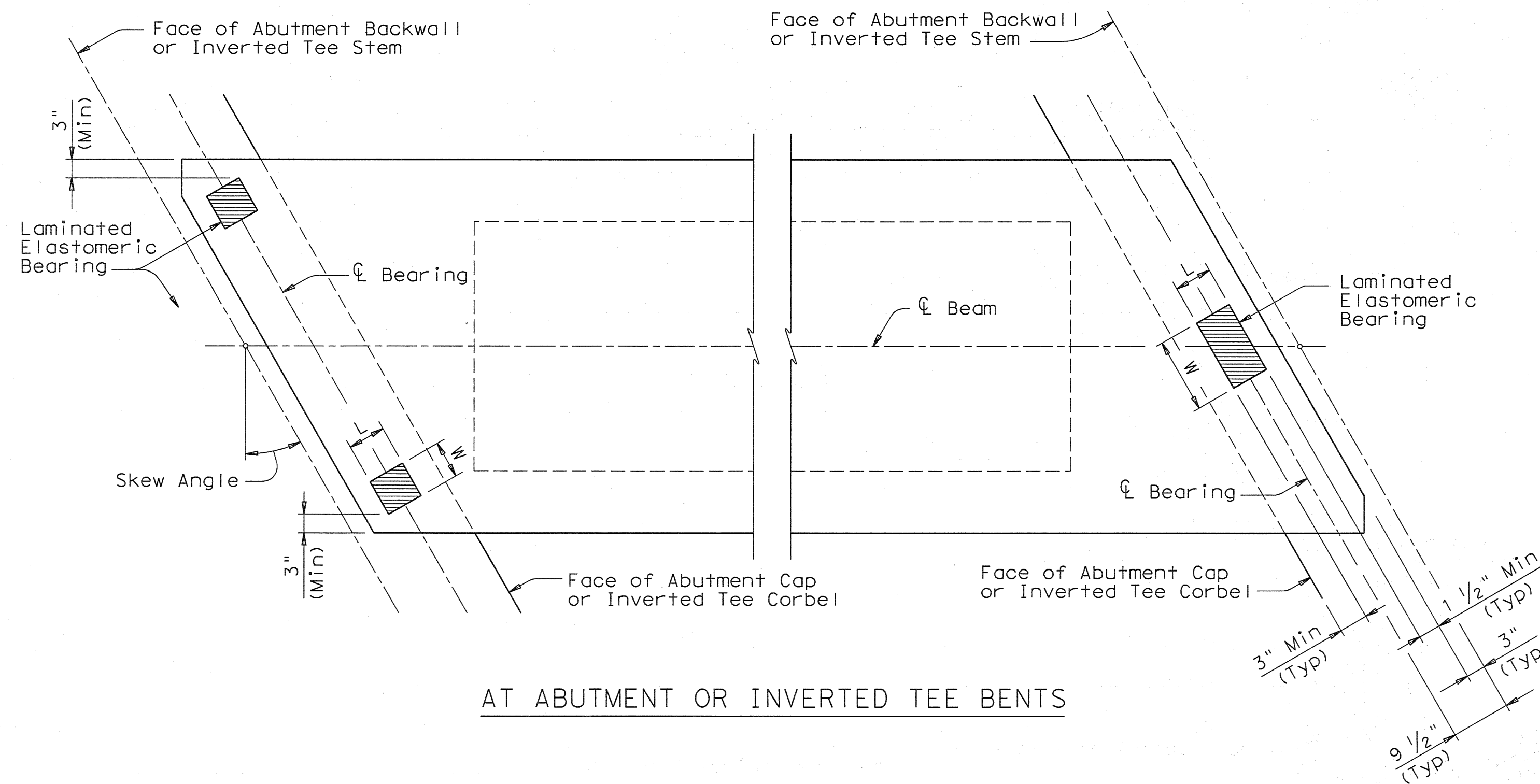

AT ABUTMENT OR INVERTED TEE BENTS

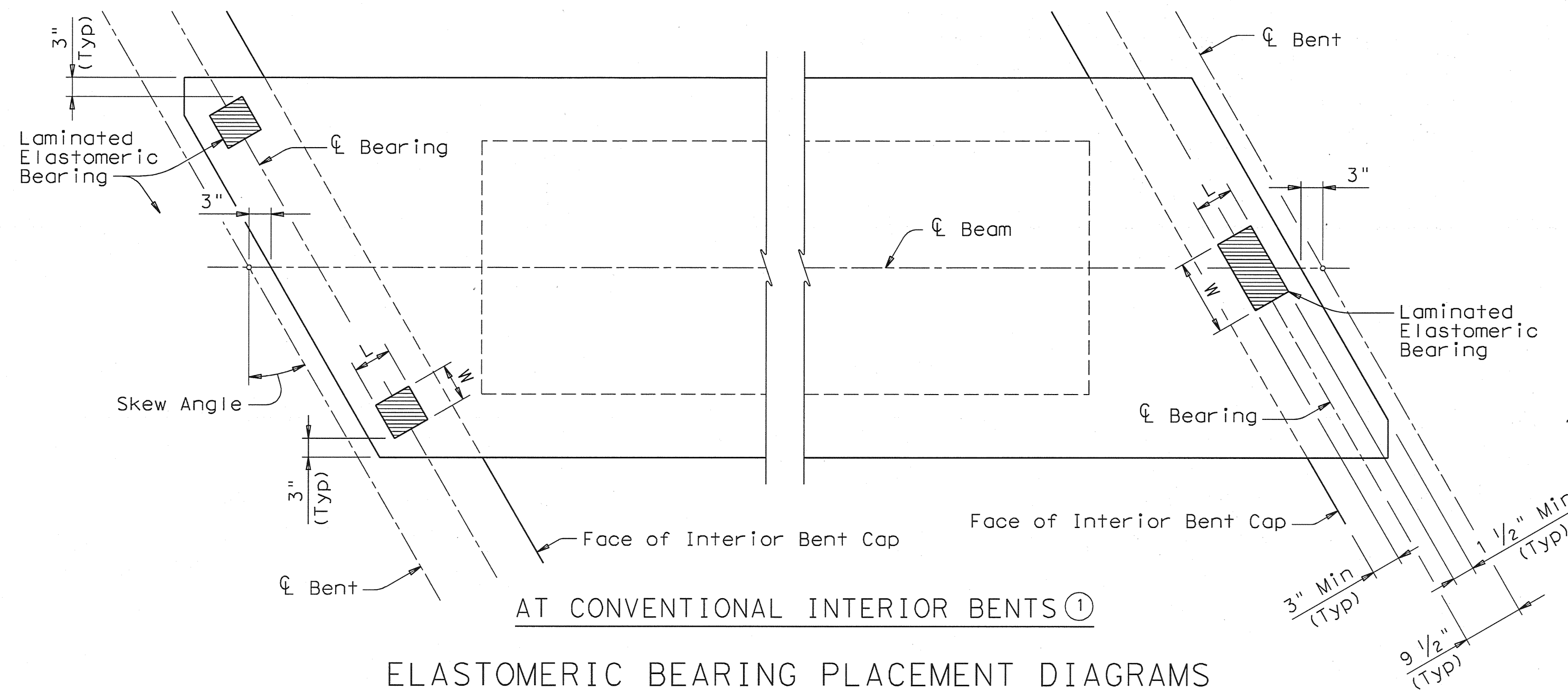

ELASTOMERIC BEARING PLACEMENT DIAGRAMS

The Forward Station Beam End will have one bearing and the Back Station Beam End will have two bearings.

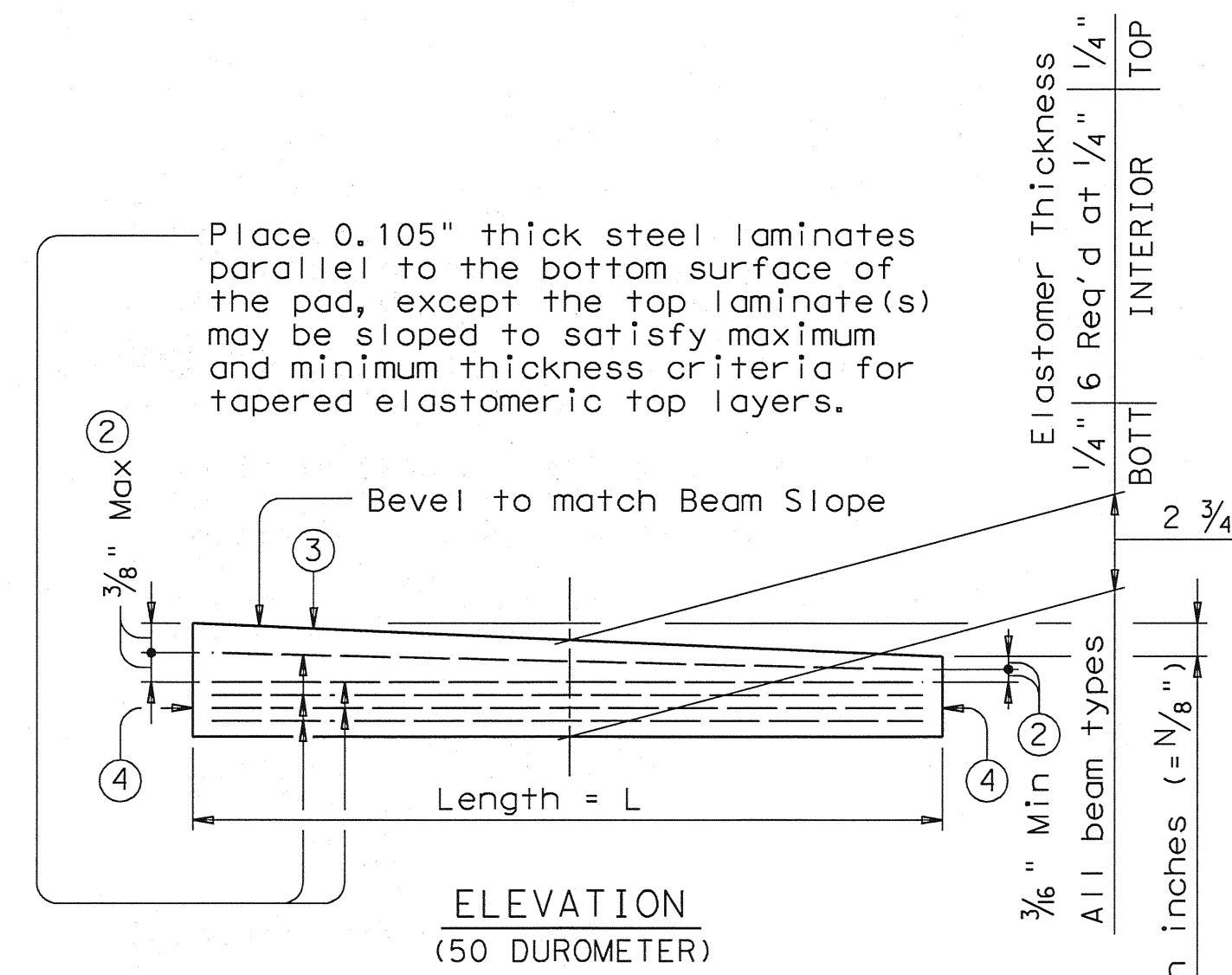

ELASTOMERIC BEARING SECTION

(50 DUROMETER)
The use of Polyisoprene (natural rubber), for the manufacture of bearing pads, is not permitted.

- ① For Transition Bents with backwall, beams and elastomeric bearings will receive the same treatment as shown for Abutment Bents.
- ② Maximum and minimum layer thicknesses shown are for elastomer only, on tapered layers.
- ③ Indicate BEARING TYPE on all pads. For tapered pads, BEARING TYPE will be located on the high side. The Fabricator will include the value of "N" (amount of taper in 1/8" increments) in this mark. Examples: N=0, (for 0" taper)
N=1, (for 1/8" taper)
N=2, (for 1/4" taper)
(etc.)
Fabricated pad top surface slope must not vary from plan beam slope by more than $(\frac{0.0625"}{\text{Length}})$ IN/IN.
- ④ Locate Permanent Mark here.

ELASTOMERIC BEARING DIMENSIONS					
BEARING TYPE	BEAM TYPE	ONE BEARING		TWO BEARINGS	
		L	W	L	W
B20-"N"	4B20	6"	12"	6"	6"
	5B20	6"	12"	6"	6"
B28-"N"	4B28	6"	14"	6"	7"
	5B28	6"	14"	6"	7"
B34-"N"	4B34	6"	16"	6"	8"
	5B34	6"	16"	6"	8"
B40-"N"	4B40	6"	20"	6"	10"
	5B40	6"	20"	6"	10"

GENERAL NOTES:

Set beams on elastomeric bearings of the dimensions shown. Center bearings as near nominal L bearing as possible within limits shown.
Constant thickness bearings may be used for moderate beam slopes up to 0.0113 ft/ft.
For skewed supports, Bearings beveled for beam slope may not provide uniform contact. However, predicted contact is considered within allowable tolerances.
Shop drawings for approval are required.
A bearing layout which identifies location and orientation of all bearings will be developed by the bearing fabricator. Permanently mark each bearing in accordance with the bearing layout. A copy of the bearing layout is to be provided to the Engineer.
Cost of furnishing and installing elastomeric bearings is to be included in unit price bid for "Prestressed Concrete Box Beams".
Details are drawn showing right forward skew. See Bridge Layout for actual direction.
These details are applicable for skews up to 30 degrees only.

HL93 LOADING

Texas Department of Transportation
Bridge Division

ELASTOMERIC BEARING DETAILS
PRESTR CONC BOX BEAMS

BEB

FILE: bbsde08.dgn	DN: TxDOT	CK: TxDOT	DW: TxDOT	CK: TxDOT
© TxDOT December 2006	DISTRICT	FEDERAL AID PROJECT		SHEET
REVISIONS				S4-07
COUNTY	CONTROL	SECT	JOB	HIGHWAY