

DISCLAIMER: The use of this standard is governed by the "Texas Engineering Practice Act". No warranty of any kind is made by TxDOT for any purpose whatsoever. TxDOT assumes no responsibility for the conversion of this standard to other formats or for incorrect results or damages resulting from its use.

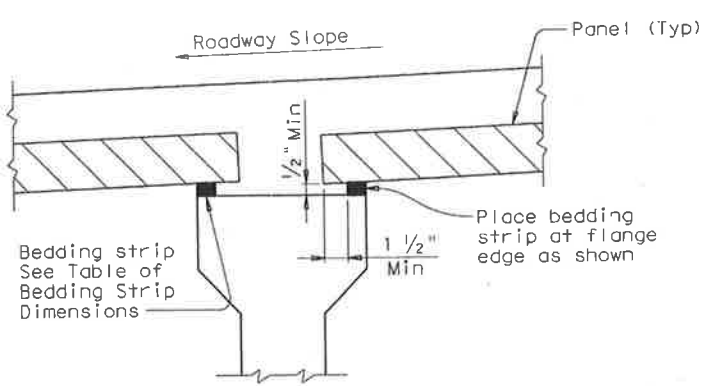

NORMAL GRADING DETAIL¹
Showing Prestressed Concrete I-Beams.
(Other Beam Types Similar)

TABLE OF BEDDING STRIP DIMENSIONS

WIDTH	HEIGHT ²	
	Min	Max
1" (Min)	1/2"	2"
1 1/4"	1/2"	2 1/2"
1 1/2"	1/2"	3"
1 3/4"	1/2"	3 1/2"
2" (Max)	1/2"	4"

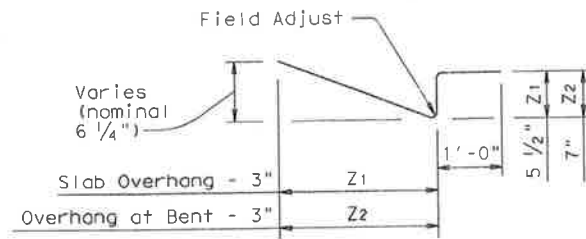

BARS Z (#4)⁷

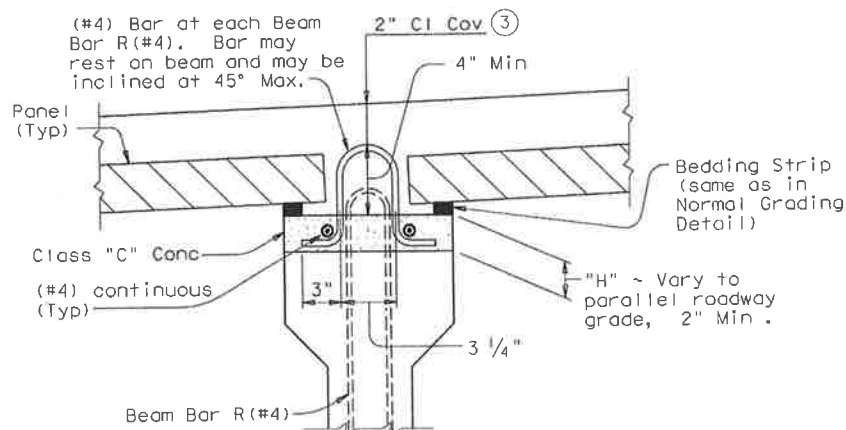

SPECIAL GRADING DETAILS FOR CONCRETE BEAMS⁴
Showing Prestressed Concrete I-Beams.
(U-Beams and I-Girders Similar)

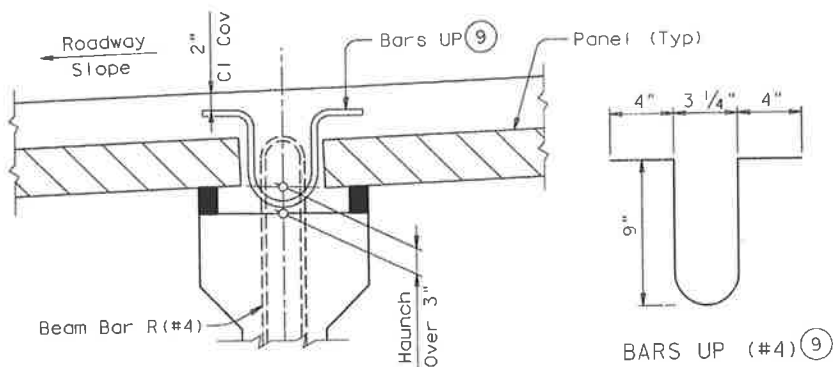

HAUNCH REINFORCING DETAIL
Showing Prestressed Concrete I-Beams.
(U-Beams and I-Girders Similar)

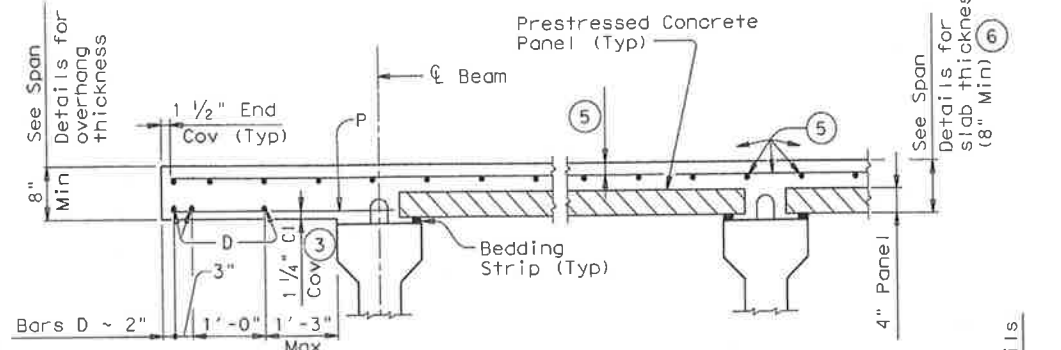

PRESTRESSED CONCRETE I-BEAMS OR I-GIRDERS

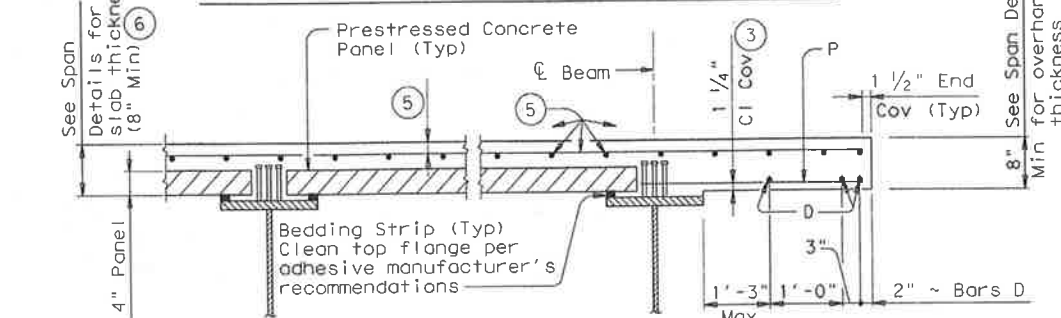

STEEL BEAMS

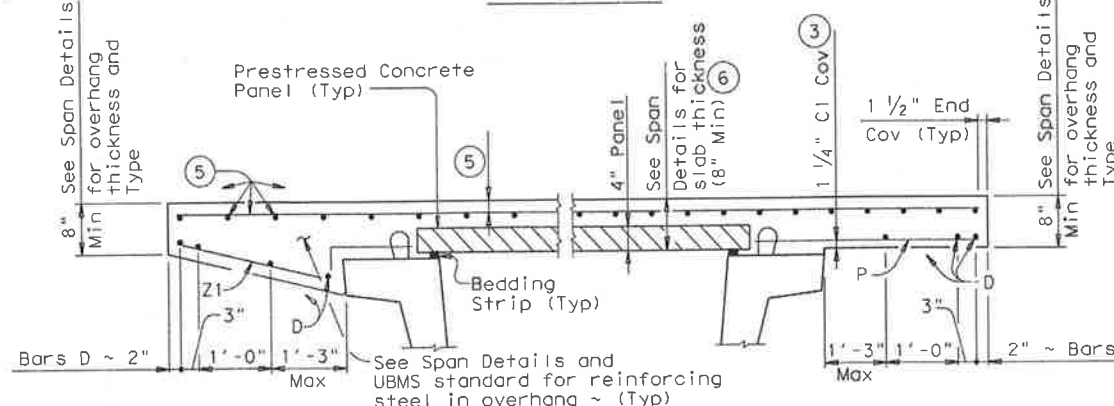

TYPICAL PART TRANSVERSE SECTIONS
SLOPED OVERHANG WITH PRESTR CONC U-BEAMS
NORMAL OVERHANG WITH PRESTR CONC U-BEAMS

- To reduce the quantity of cast-in-place concrete, bedding strip thickness may be increased in 1/4" increments. Bedding strips must be comprised of one layer. Bond bedding strips to the beams with an adhesive compatible with bedding strips. Bedding strips over 2.5" high may need to be bonded to panels. The same thickness strip must be used under any one panel edge and the maximum change in thickness between adjacent panels must be 1/4". Alternatively, bedding strips may be cut to grade. Panels may be supported by an alternate method, using a commercial product, if approved by the Engineer of Bridge Design, Bridge Division.
- Height must not exceed twice the width.
- Clear cover shall be as indicated unless otherwise shown on Span Details.
- For use where the distance between top of beam and finished grade can not be achieved within tolerances on cast-in-place slab thickness and thickness of bedding strips. Control dimensions shown in Normal Grading Detail still apply.
- See Span Details for top slab reinforcement and clear cover. Longitudinal top slab reinforcement may rest on top of prestressed concrete panels if necessary to maintain clear cover.
- The actual thickness constructed may exceed the slab thickness shown on the Span Details but, the extra thickness shall be no more than 2" for Prestressed Concrete I-Beams and 1" for Prestressed Concrete U-Beams and Steel Beams. Bearing Seat Elevations or finished grade may be adjusted.
- Bars Z1(#4) shall be field adjusted to match actual slope of slab overhangs. Width of slab overhang will vary along span with curved slab edges. Adjust Bar Z1(#4) dimensions to maintain proper cover. Bars Z2(#4) are located at Inv-T stems only.
- Max Spacing as listed unless otherwise shown.
- Space Bars UP(#4) with Beam Bars R(#4) in all areas where measured haunch exceeds 3".

CONSTRUCTION NOTES:
Erected panels must bear uniformly on bedding strips of extruded polystyrene placed along top flange edges.
If additional blocking is needed, special grading details for supporting the panels and extra reinforcing between beam and slab will be considered subsidiary to deck construction.
Care must be taken to ensure proper cleaning of construction debris and consolidation of concrete mortar under the edges of the panels. Bedding strips must be placed at beam flange edges so that adequate space is provided for the mortar to flow a minimum of 1 1/2" under the panels as the slab concrete is placed.
To allow the proper amount of mortar to flow between beam and panel, the minimum vertical opening must be at least 1/2". Roadway cross-slope reduces the opening available for entry of the mortar. Bedding strips varying in thickness across the beam are therefore required.

All reinforcing steel in the cast-in-place slab must be Grade 60. See Table of Reinforcing Steel for size and spacing of reinforcement. Orientation of reinforcement (normal or skewed) must match that shown on the Span Details.
If the top and bottom layer of reinforcing steel is shown on the Span Details to be epoxy coated, then the A, D, E, P, & Z bars must be epoxy coated.
For clear span between U-beams less than or equal to 18", see Permissible Slab Forming Detail on Miscellaneous Slab Detail sheets, UBMS.
Bar Laps, where required, must be as follows:
Uncoated ~ #4 = 1'-5"
~ #5 = 1'-9"
Epoxy Coated ~ #4 = 2'-1"
~ #5 = 2'-7"

GENERAL NOTES:
Designed according to AASHTO LRFD Specifications.
Use of Prestressed Concrete Panels is not permitted for horizontally curved steel plate or tub girders. See Span Details for other possible restrictions on their use.
These details are to be used in conjunction with the Span Details and applicable Standard sheets.
Any additional reinforcement or concrete required on this standard is to be considered subsidiary to the bid item "Reinforced Concrete Slab".

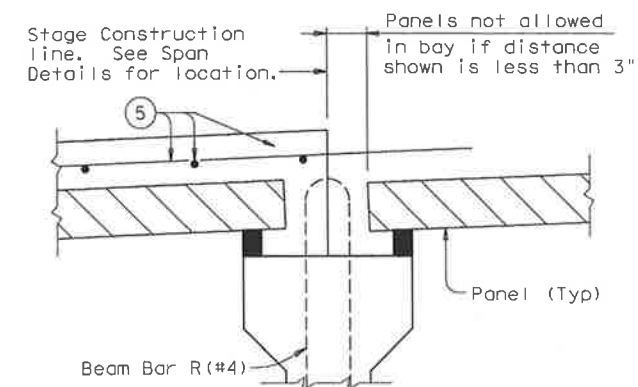

STAGE CONSTRUCTION LIMITATIONS ON PANELS
Showing Prestressed Concrete I-Beams.
(Other Beam Types Similar)

TABLE OF REINFORCING STEEL⁸

BAR	SIZE	Max Spa (in.)
A	#5	~
D	#5	9
E	#5	6
P	#4	18
UP	#4	~
Z	#4	18

Texas Department of Transportation
Bridge Division

PRESTRESSED CONCRETE PANELS
OPTIONAL DECK DETAILS FOR BEAM SPANS

PCP

FILE: pcpsdel.dgn	DN: TxDOT	CK: TxDOT	DW: TxDOT	CR: TxDOT
© TxDOT April 2006		DISTRICT		FEDERAL AID PROJECT
REVISIONS		COUNTY		CONTROL SECT
08-07: Added I-Girders and added note to WBR splice detail.		JOB		HIGHWAY

SHEET S4-09

LEVELS DISPLAYED

1	ACC:
2	
3	
4	
5	
6	
7	
8	
9	
10	
11	
12	
13	
14	
15	
16	
17	
18	
19	
20	
21	
22	
23	
24	
25	
26	
27	
28	
29	
30	