

205 - 460 DUCT TERMINATOR ALIGNMENTS FOR PRECAST CONCRETE MANHOLES

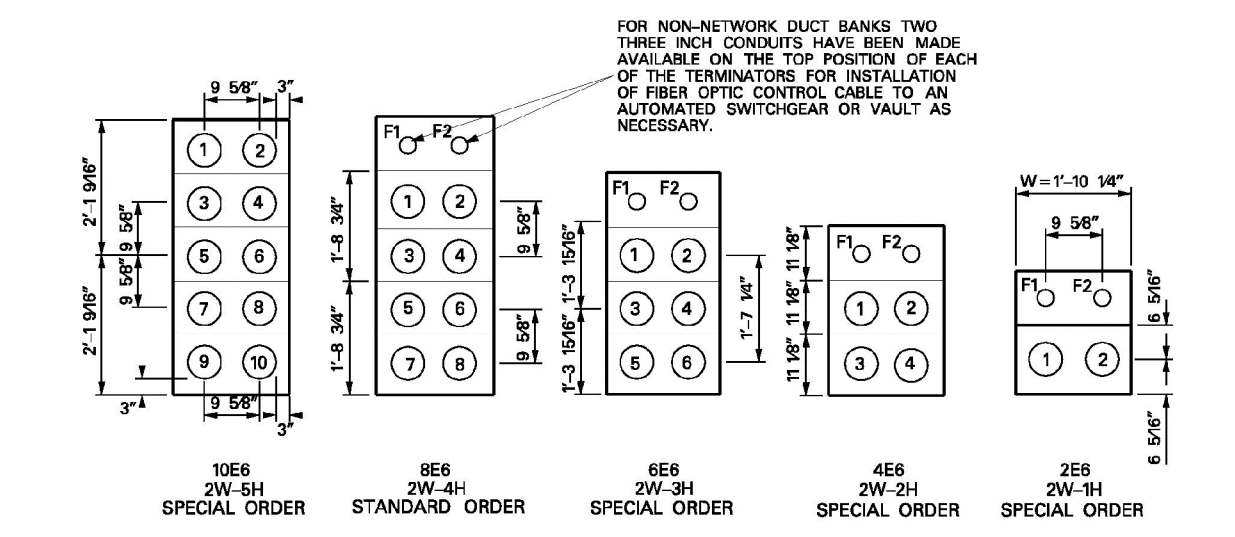

ALIGNMENT FOR NON-NETWORK MANHOLE DUCT TERMINATION FOR 6" CONDUIT (TYPICAL)

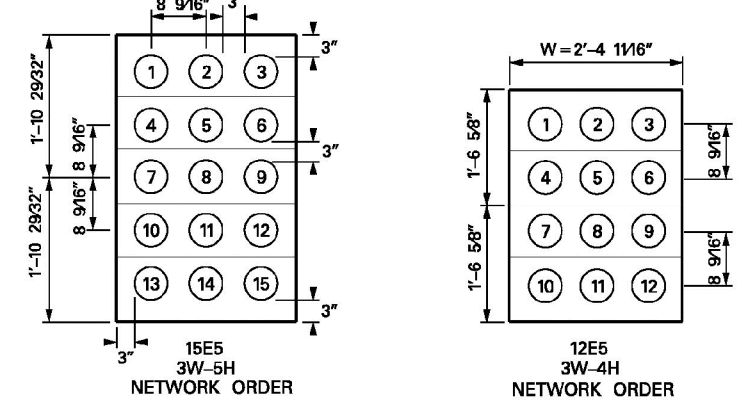

ALIGNMENT FOR NETWORK MANHOLE DUCT TERMINATION FOR 5" CONDUIT (TYPICAL)

- NOTES:**
- THE NUMBERING SYSTEM SHOWN ASSUMES ONE IS STANDING IN THE CENTER OF THE MANHOLE FACING THE TERMINATOR WALL.
 - IN THE EVENT THAT ALL OF THE AVAILABLE CONDUIT POSITIONS OF THE TERMINATOR ARE NOT NEEDED FOR AN INSTALLATION, THE BOTTOM CONDUIT POSITIONS SHOULD BE USED FIRST TO ALLOW FOR FUTURE CONDUIT EXITS FROM THE MANHOLE.
 - TO PREVENT WATER AND DEBRIS MIGRATION INTO THE MANHOLE, DO NOT REMOVE THE "KNOCK-OUT" MEMBRANES OF ANY UNUSED TERMINATOR POSITION. ALSO DUCT PLUGS SHOULD BE INSTALLED IN ALL CONDUITS THAT ARE UN-OCCUPIED BY CABLE.
 - A 5 INCH CONDUIT IS TO BE USED FOR DUCT PROJECTS WITHIN THE NETWORK DISTRIBUTION SYSTEMS ONLY. CABLE SIZES NECESSARY FOR NON-NETWORK DUCT SYSTEMS WILL REQUIRE 6 INCH CONDUIT INSTALLATIONS.
 - THE SYSTEMS DEPICTED ABOVE ARE MANHOLE FACING CONDUIT/DUCT SYSTEM TERMINATORS ONLY, AND SHOULD NOT BE MISTAKEN FOR DUCT SECTION DETAILS.
 - THE THREE INCH CONDUIT FOR FIBER OPTIC CABLE HAS BEEN OMITTED ON THE 1068 DUCT DUE TO A LACK OF WALL SPACE.

ITEM	QTY	DESCRIPTION	TSN/REF	CU	MU
1	1	MANHOLE 4-WAY PRE-CAST CONCRETE WITH COVER AND FRAME.	318942	MANHOLE4W	
2	2	ROD, GROUND, COPPER CLAD STEEL, 5/8 INCH X 8 FOOT	300524	MH4WCUST	GSSP1021M

APPROVED BY

205 - 465 MANHOLE LARGE FOUR WAY PRECAST REINFORCED CONCRETE

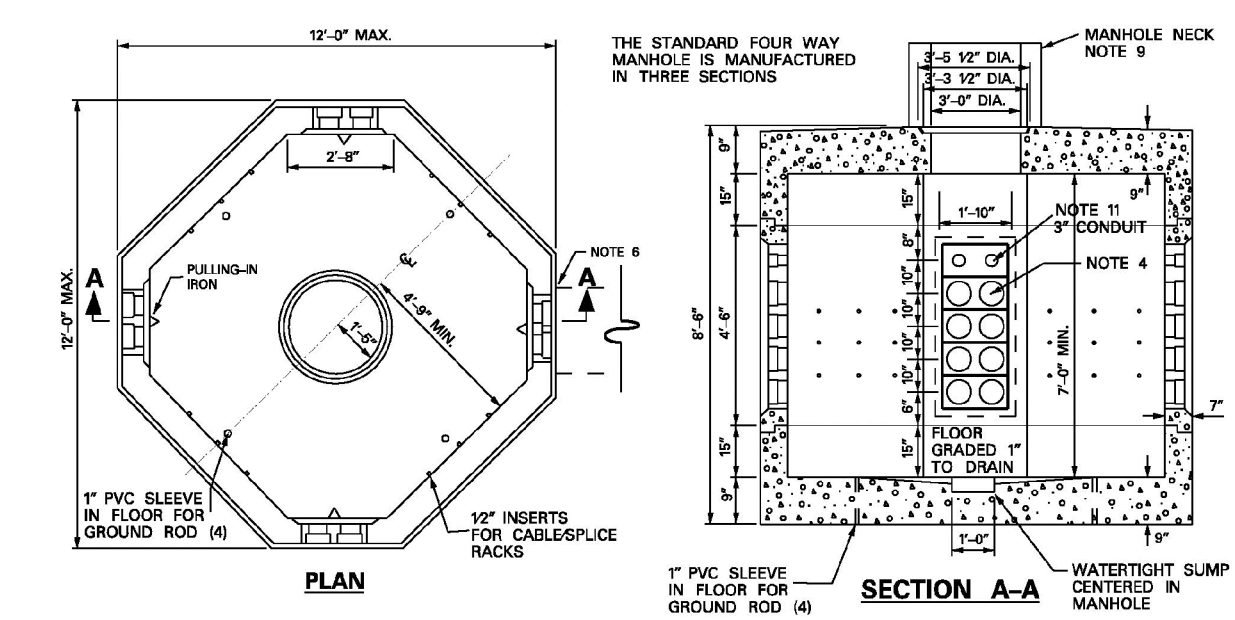

- NOTES:**
- STANDARD MANHOLES ARE SHOWN IN DRAWINGS 205-465, 205-470 AND 205-475.
 - THE MAXIMUM DESIGN DEPTH FOR A MANHOLE IS 20 FEET TO THE FINISHED FLOOR. THIS INCLUDES 12 FEET OF NECK (FOR DEPTHS GREATER THAN THIS CONTACT DISTRIBUTION STANDARDS).
 - MANHOLES SHALL BE USED FOR LOCATIONS AS FOLLOWS:
 - WHERE MULTIPLE CIRCUITS OF UNDERGROUND PRIMARY VOLTAGE CONDUCTOR ARE TO BE PULLED IN AND/OR SPliced.
 - WHERE SPlicing POINT WILL BE IN A STREET OR TRAFFIC AREA (CONDUCTOR SIZES 10 AND UP) (NOTE: 4X8 SPlicing BOX IS NOT DESIGNED FOR APPLICATIONS WHERE THERE WILL BE ANY INTENTIONAL VEHICULAR TRAFFIC).
 - SEE DRAWING 205-460 FOR DETAILS ON TERMINATOR SPECIFICATIONS AND DIMENSIONS DENOTED BY W AND H.
 - ALL JOINTS BETWEEN MANHOLE SECTIONS AND MANHOLE NECK SECTIONS SHALL BE PAINTED WITH "RAM-NEK" PRIMER OR APPROVED EQUAL BY MANHOLE SUPPLIER. ALL JOINTS SHALL BE MADE WATERTIGHT AT THE TIME OF INITIAL INSTALLATION.
 - TO PREVENT WATER AND DEBRIS MIGRATION INTO THE MANHOLE, DO NOT REMOVE THE "KNOCK-OUT" MEMBRANES OF ANY UN-USED TERMINATOR POSITION. ALSO DUCT PLUGS SHOULD BE INSTALLED IN ALL CONDUITS THAT ARE UN-OCCUPIED BY CABLE.
 - FINAL SLOPE OF TOP OF MANHOLE SHALL BE 2" MINIMUM TO DRAIN WATER FROM TOP OF MANHOLE.
 - A MINIMUM OF FOUR 5/8 IN X 8 FT. COPPER CLAD GROUND RODS SHALL BE INSTALLED IN EACH MANHOLE.
 - SEE DRAWING 205-460 FOR NECK DETAILS AND 205-465 FOR LID AND FRAME SPECIFICATIONS.
 - PRE-CAST CONCRETE MANHOLES ARE TO BE INSTALLED ON A MINIMUM OF AN 18" GRAVEL BASE TO AID IN LEVELING.
 - IF FIBER OPTIC CONTROL CABLE IS TO BE INSTALLED IN THE DUCT SYSTEM, ONE OF THE TOP 4" CONDUITS SHOULD BE USED IF AVAILABLE (SEE DRAWING 205-460 FOR FIBER OPTIC CABLE RACKING REQUIREMENTS). FOR FIBER OPTIC CONTROL CABLE INSTALLED FROM MANHOLE TO SWITCHGEAR PAD USE 3" CONDUIT TERMINATION ABOVE 6" CONFIGURATION (SEE DRAWING 205-342).

ITEM	QTY	DESCRIPTION	TSN/REF	CU	MU
1	1	MANHOLE 4-WAY PRE-CAST CONCRETE WITH COVER AND FRAME.	318942	MANHOLE4W	
2	2	ROD, GROUND, COPPER CLAD STEEL, 5/8 INCH X 8 FOOT	300524	MH4WCUST	GSSP1021M

APPROVED BY

205 - 470 MANHOLE LARGE TWO WAY PRECAST REINFORCED CONCRETE

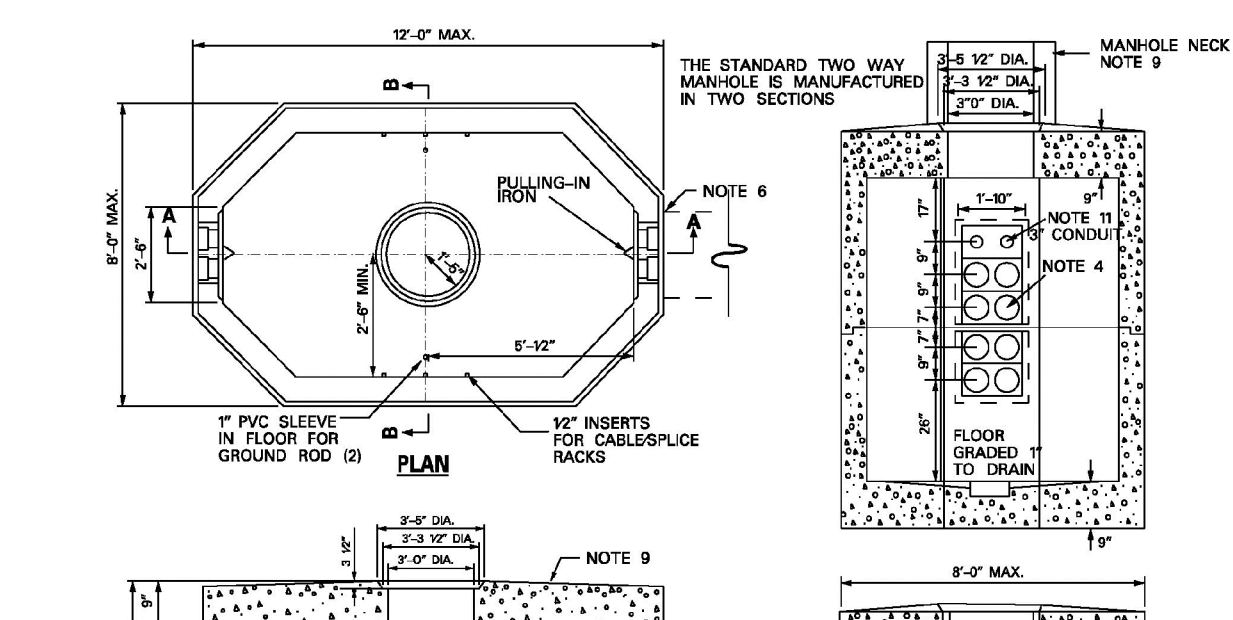

- NOTES:**
- STANDARD MANHOLES ARE SHOWN IN DRAWINGS 205-465, 205-470 AND 205-475.
 - THE MAXIMUM DESIGN DEPTH FOR A MANHOLE IS 20 FEET TO THE FINISHED FLOOR. THIS INCLUDES 12 FEET OF NECK (FOR DEPTHS GREATER THAN THIS CONTACT DISTRIBUTION STANDARDS).
 - MANHOLES SHALL BE USED FOR LOCATIONS AS FOLLOWS:
 - WHERE MULTIPLE CIRCUITS OF UNDERGROUND PRIMARY VOLTAGE CONDUCTOR ARE TO BE PULLED IN AND/OR SPliced.
 - WHERE SPlicing POINT WILL BE IN A STREET OR TRAFFIC AREA (CONDUCTOR SIZES 10 AND UP) (NOTE: 4X8 SPlicing BOX IS NOT DESIGNED FOR APPLICATIONS WHERE THERE WILL BE ANY INTENTIONAL VEHICULAR TRAFFIC).
 - SEE DRAWING 205-460 FOR DETAILS ON TERMINATOR SPECIFICATIONS AND DIMENSIONS DENOTED BY W AND H.
 - ALL JOINTS BETWEEN MANHOLE SECTIONS AND MANHOLE NECK SECTIONS SHALL BE PAINTED WITH "RAM-NEK" PRIMER OR APPROVED EQUAL BY MANHOLE SUPPLIER. ALL JOINTS ARE TO BE MADE WATERTIGHT AT THE TIME OF INITIAL INSTALLATION.
 - TO PREVENT WATER AND DEBRIS MIGRATION INTO THE MANHOLE, DO NOT REMOVE THE "KNOCK-OUT" MEMBRANES OF ANY UN-USED TERMINATOR POSITION. ALSO DUCT PLUGS SHOULD BE INSTALLED IN ALL CONDUITS THAT ARE UN-OCCUPIED BY CABLE.
 - FINAL SLOPE OF TOP OF MANHOLE SHALL BE 2" MINIMUM TO DRAIN WATER FROM TOP OF MANHOLE.
 - A MINIMUM OF TWO 5/8 IN X 8 FT. COPPER CLAD GROUND RODS SHALL BE INSTALLED IN EACH MANHOLE.
 - SEE DRAWING 205-460 FOR NECK DETAILS AND 205-465 FOR LID AND FRAME SPECIFICATION.
 - PRE-CAST CONCRETE MANHOLES ARE TO BE INSTALLED ON A MINIMUM OF AN 18" GRAVEL BASE TO AID IN LEVELING.
 - IF FIBER OPTIC CONTROL CABLE IS TO BE INSTALLED IN THE DUCT SYSTEM, ONE OF THE TOP 4" CONDUITS SHOULD BE USED IF AVAILABLE (SEE DRAWING 205-460 FOR FIBER OPTIC CABLE RACKING REQUIREMENTS). FOR FIBER OPTIC CONTROL CABLE INSTALLED FROM MANHOLE TO SWITCHGEAR PAD USE 3" CONDUIT TERMINATION ABOVE 6" CONFIGURATION (SEE DRAWING 205-342).

ITEM	QTY	DESCRIPTION	TSN/REF	CU	MU
1	1	MANHOLE 2-WAY PRE-CAST CONCRETE WITH COVER AND FRAME	323109	MANHOLE2W	
2	2	ROD, GROUND, COPPER CLAD STEEL, 5/8 INCH X 8 FOOT	300524	MH2WCUST	GSSP1021M

APPROVED BY

205 - 475 MANHOLE LARGE THREE WAY PRECAST REINFORCED CONCRETE

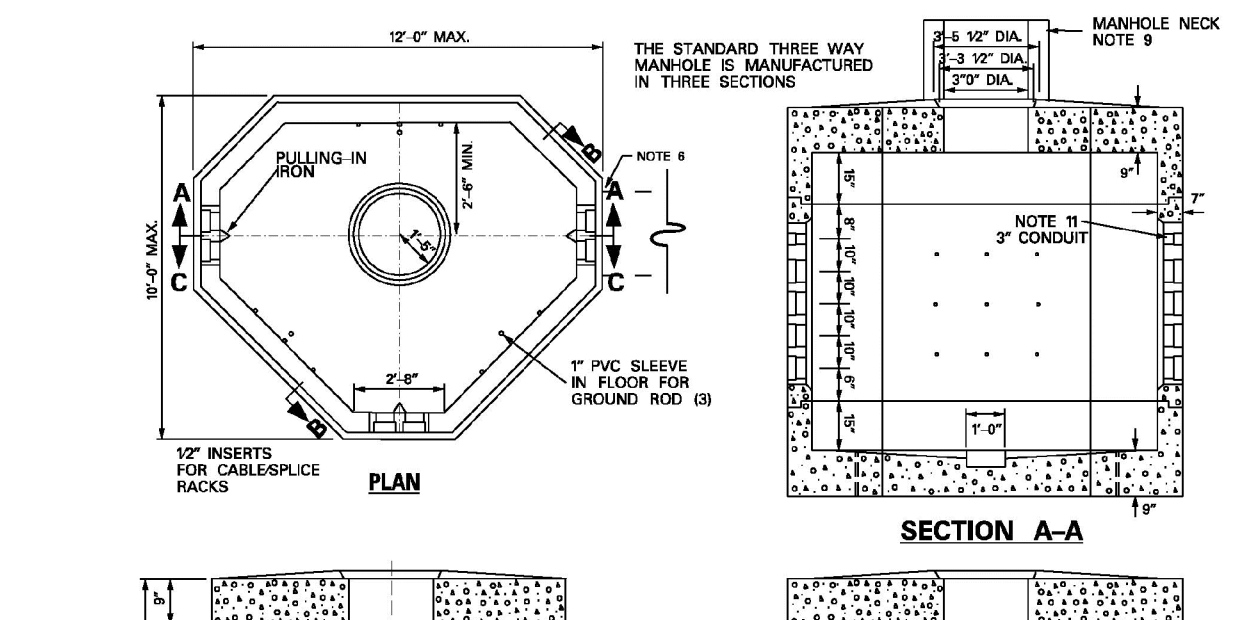

- NOTES:**
- STANDARD MANHOLES ARE SHOWN IN DRAWINGS 205-465, 205-470 AND 205-475.
 - THE MAXIMUM DESIGN DEPTH FOR A MANHOLE IS 20 FEET TO THE FINISHED FLOOR. THIS INCLUDES 12 FEET OF NECK (FOR DEPTHS GREATER THAN THIS CONTACT DISTRIBUTION STANDARDS).
 - MANHOLES SHALL BE USED FOR LOCATIONS AS FOLLOWS:
 - WHERE MULTIPLE CIRCUITS OF UNDERGROUND PRIMARY VOLTAGE CONDUCTOR ARE TO BE PULLED IN AND/OR SPliced.
 - WHERE SPlicing POINT WILL BE IN A STREET OR TRAFFIC AREA (CONDUCTOR SIZES 10 AND UP) (NOTE: 4X8 SPlicing BOX IS NOT DESIGNED FOR APPLICATIONS WHERE THERE WILL BE ANY INTENTIONAL VEHICULAR TRAFFIC).
 - SEE DRAWING 205-460 FOR DETAILS ON TERMINATOR SPECIFICATIONS AND DIMENSIONS DENOTED BY W AND H.
 - ALL JOINTS BETWEEN MANHOLE SECTIONS AND MANHOLE NECK SECTIONS SHALL BE PAINTED WITH "RAM-NEK" PRIMER OR APPROVED EQUAL BY MANHOLE SUPPLIER. ALL JOINTS ARE TO BE MADE WATERTIGHT AT THE TIME OF INITIAL INSTALLATION.
 - TO PREVENT WATER AND DEBRIS MIGRATION INTO THE MANHOLE, DO NOT REMOVE THE "KNOCK-OUT" MEMBRANES OF ANY UN-USED TERMINATOR POSITION. ALSO DUCT PLUGS SHOULD BE INSTALLED IN ALL CONDUITS THAT ARE UN-OCCUPIED BY CABLE.
 - FINAL SLOPE OF TOP OF MANHOLE SHALL BE 2" MINIMUM TO DRAIN WATER FROM TOP OF MANHOLE.
 - A MINIMUM OF THREE 5/8 IN X 8 FT. COPPER CLAD GROUND RODS SHALL BE INSTALLED IN EACH MANHOLE.
 - SEE DRAWING 205-460 FOR NECK DETAILS AND 205-465 FOR LID AND FRAME SPECIFICATION.
 - PRE-CAST CONCRETE MANHOLES ARE TO BE INSTALLED ON A MINIMUM OF AN 18" GRAVEL BASE TO AID IN LEVELING.
 - IF FIBER OPTIC CONTROL CABLE IS TO BE INSTALLED IN THE DUCT SYSTEM, ONE OF THE TOP 4" CONDUITS SHOULD BE USED IF AVAILABLE (SEE DRAWING 205-460 FOR FIBER OPTIC CABLE RACKING REQUIREMENTS). FOR FIBER OPTIC CONTROL CABLE INSTALLED FROM MANHOLE TO SWITCHGEAR PAD USE 3" CONDUIT TERMINATION ABOVE 6" CONFIGURATION (SEE DRAWING 205-342).

ITEM	QTY	DESCRIPTION	TSN/REF	CU	MU
1	1	MANHOLE 3-WAY PRE-CAST CONCRETE WITH COVER AND FRAME	323108	MANHOLE3W	
2	2	ROD, GROUND, COPPER CLAD STEEL, 5/8 INCH X 8 FOOT	300524	MH3WCUST	GSSP1021M

APPROVED BY

205 - 480 MANHOLE NECK, LADDER AND ENTRANCE PAD INSTALLATION

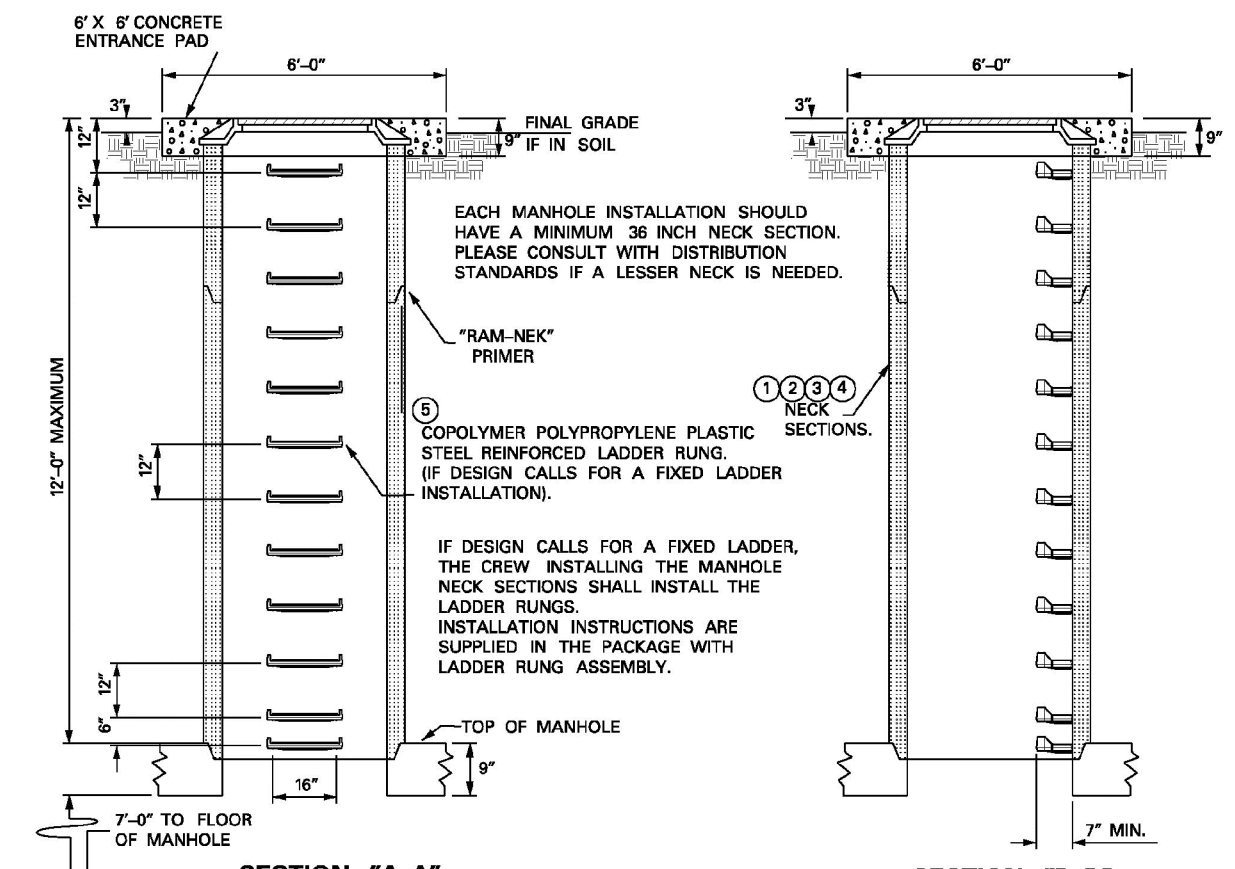
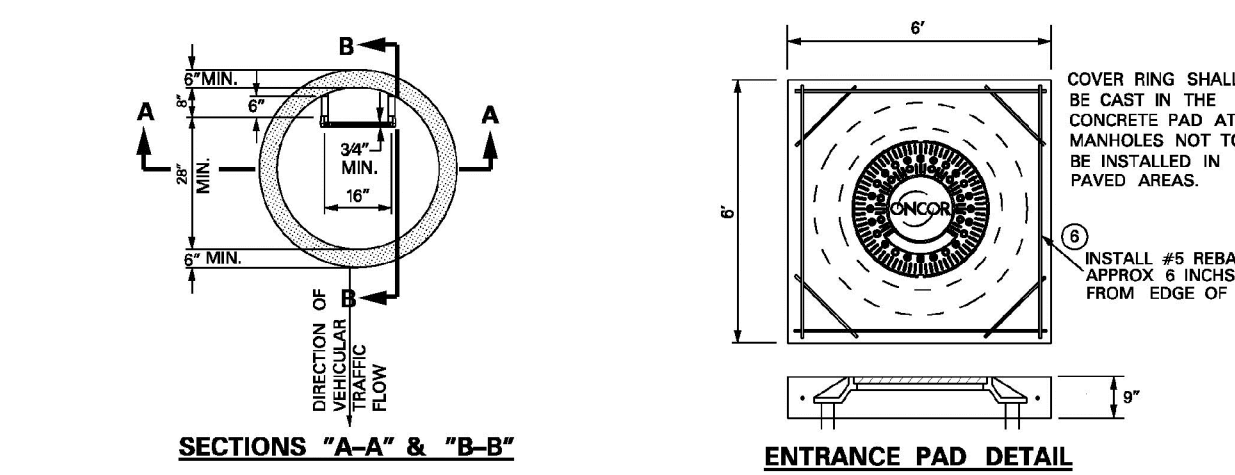

ITEM	QTY	DESCRIPTION	TSN/REF	CU	MU
1	AS REQ.	12 IN. X 36 IN. PRECAST CONCRETE NECK SECTION.	320774	MN8X12	
2	AS REQ.	18 IN. X 36 IN. PRECAST CONCRETE NECK SECTION.	320775	MN8X18	
3	AS REQ.	24 IN. X 36 IN. PRECAST CONCRETE NECK SECTION.	320776	MN8X24	
4	AS REQ.	36 IN. X 36 IN. PRECAST CONCRETE NECK SECTION.	320777	MN8X36	
5	AS REQ.	COPOLYMER POLYPROPYLENE PLASTIC STEEL REINFORCED LADDER RUNG.	48281	MHSTEP	
6	AS REQ.	BAR, STEEL REINFORCING, DEFORMED, 3/8 X 20 FT, ASTM A-618, GRADE 60.	303750		

APPROVED BY

205 - 485 MANHOLE COVER AND FRAME DETAIL

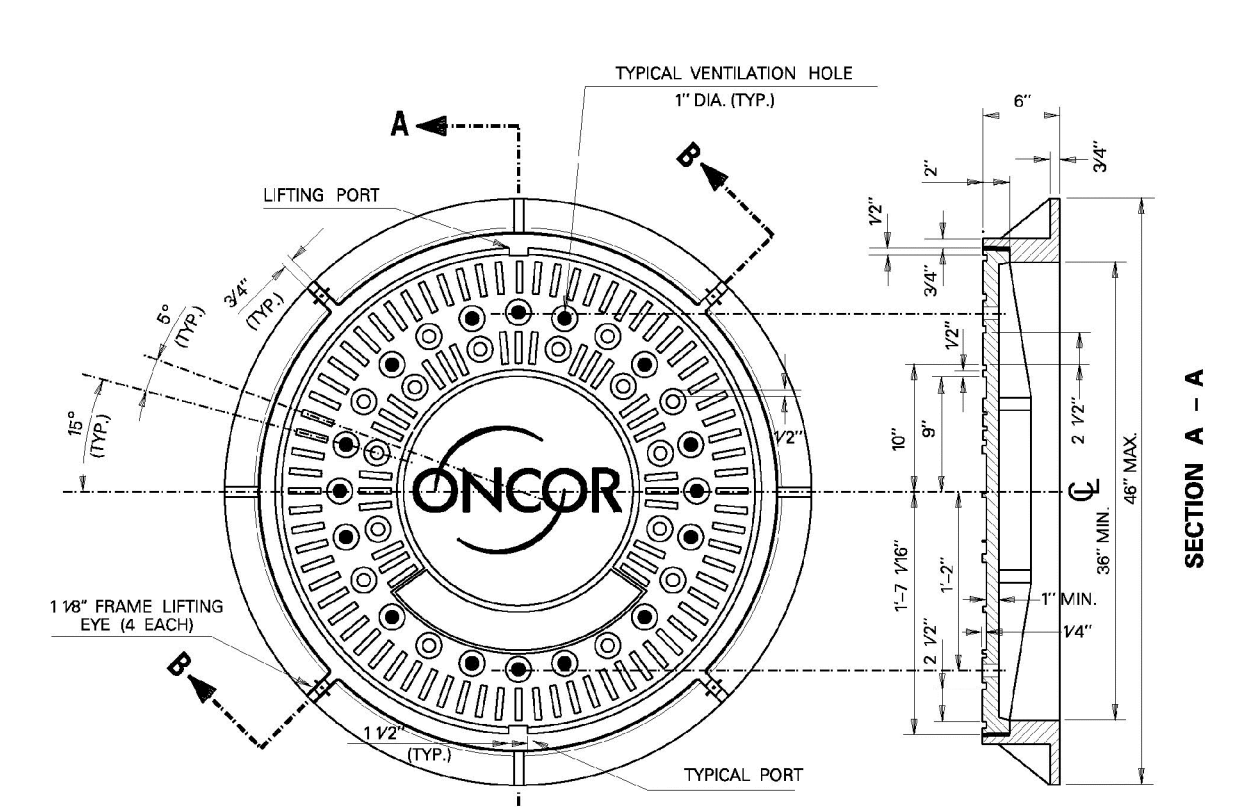

- NOTES:**
- BEARING SURFACE BETWEEN COVER AND FRAME SHALL BE MACHINED.
 - COVER AND FRAME SHALL BE CONSTRUCTED TO AASHTO H-20 FULL TRAFFIC RATING LOAD REQUIREMENTS.
 - COVER AND FRAME SHALL BE CONSTRUCTED OF GRAY CAST IRON CONFORMING TO ASTM-A54-LATCOT REVISION CLASS 3B.
 - MANHOLE COVER AND FRAME SHALL NOT EXCEED 700 LBS.

ITEM	QTY	DESCRIPTION	TSN/REF	CU	MU
1	1	MANHOLE COVER AND FRAME, INTENTIONAL TRAFFIC RATED.	327653		

APPROVED BY

205 - 490 GENERAL GUIDELINES FOR CONCRETE ENCASED DUCTBANK INSTALLATIONS (NON-NETWORK)

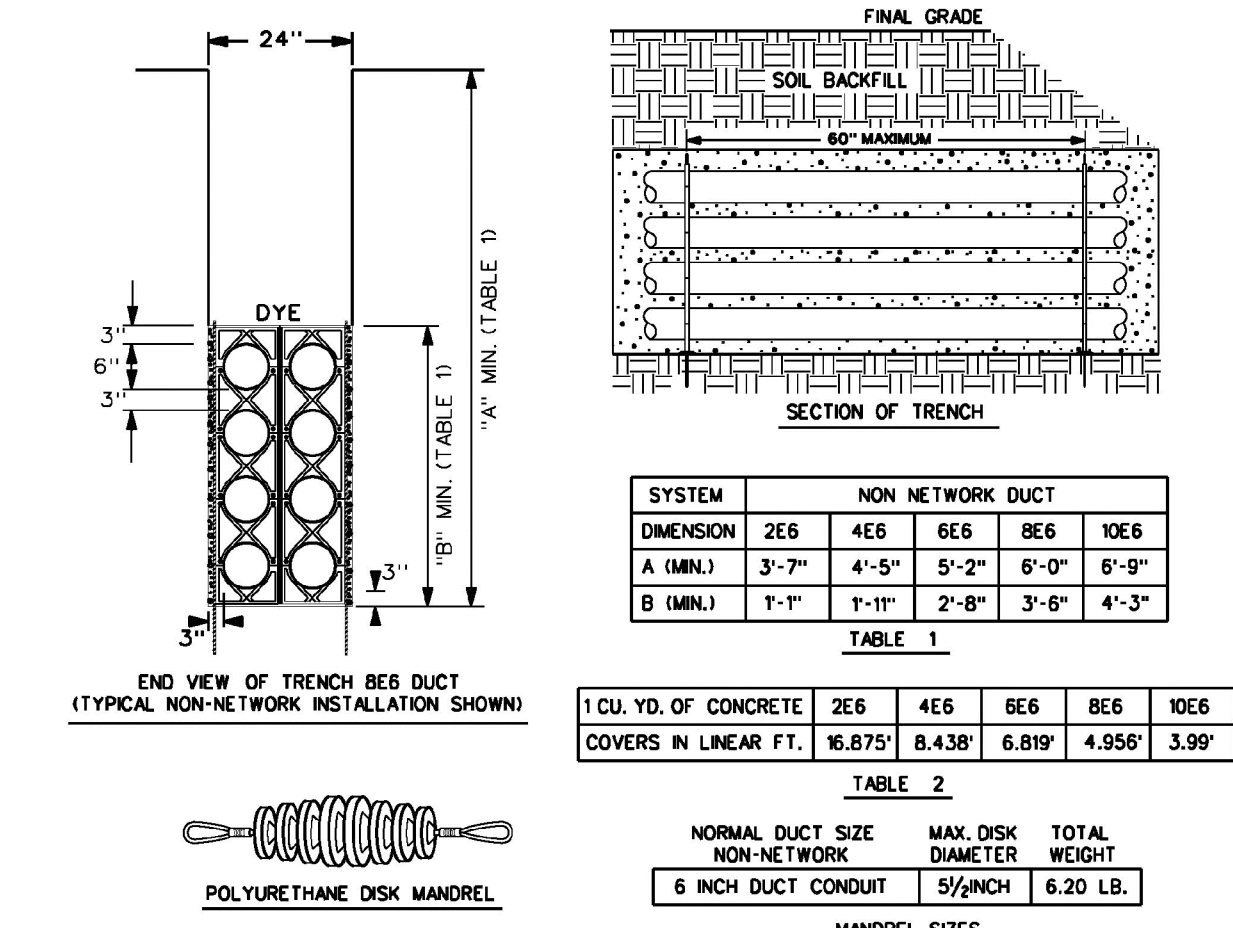

- NOTES:**
- CONDUIT IS TO BE PVC TYPE DB-60 FOR CONCRETE ENCASEMENT.
 - ALL CONCRETE OF THE ENCASEMENT IS TO HAVE A COMPRESSION TEST STRENGTH OF 3000 PSIA AT TWENTY EIGHT DAYS.
 - INSTALL DUCT SPACERS (CARLON (SNAP-LOC) TYPE OR EQUAL) EVERY 5 FEET ALONG THE ENTIRE LENGTH OF THE DUCT.
 - THE DUCT SPACERS ARE TO PROVIDE 3 INCHES OF VERTICAL AND HORIZONTAL SEPARATION BETWEEN CONDUITS FOR NON-NETWORK SYSTEM INSTALLATIONS.
 - THE DUCT SPACERS ARE TO PROVIDE 1 1/2 INCHES OF VERTICAL AND HORIZONTAL SEPARATION BETWEEN CONDUITS FOR NETWORK SYSTEM INSTALLATIONS.
 - THE DUCT LINE SHALL BE SECURED TO EARTH AT EACH SPACER LOCATION PRIOR TO POURING CONCRETE TO PREVENT THE CONDUIT FROM FLOATING.
 - ALL CONDUIT/DUCT SPANS SHOULD BE INSTALLED WITH A SLOPE TOWARD EACH OF THE MANHOLES TO PROVIDE DRAINAGE OF WATER TO A PUMPABLE LOCATION.
 - ALL BACKFILL OF A CONDUIT/DUCT TRENCH SHALL BE REPLACED TO A MINIMUM COMPACTION OF 95%.
 - RED POWDER CONCRETE DYE IS TO BE PLACED ON THE DUCT ENCASEMENT CAP IMMEDIATELY AFTER THE CONCRETE POUR HAS TAKEN PLACE TO AID WITH FUTURE LOCATES OF PRIMARY DUCT.
 - CONDUITS FOR INCOMPLETE DUCT LINES (STUBS), ARE TO REMAIN EXPOSED FROM THE ENCASEMENT FOR FUTURE RETRIEVAL BE CAPEP WATERTIGHT AND HAVE AN ELECTRONIC MARKER INSTALLED.
 - EACH JOINT OF A CONCRETE ENCASED DUCT SHALL BE INSPECTED BY PULLING A DISK MANDREL OF PROPER SIZE THRU ITS ENTIRE LENGTH AS SOON AS POSSIBLE AFTER ITS ENCASEMENT HAS BEEN POURED TO INSURE ITS INTEGRITY.
 - EACH 9 OR 5 INCH CONDUIT OF AN ENCASED DUCT IS TO HAVE A 900 LB. FULL TAPE INSTALLED FOR FUTURE CABLE PULLING.

ITEM	QTY	DESCRIPTION	TSN/REF	CU	MU
1	AS REQ.	DUCT BANK, CONDUIT, 6 IN., LESS SPACERS & CONCRETE, NON-NETWORK.	316990	DBX	
2	AS REQ.	FITTING, CONDUIT, PVC, SPACER, BASE/TOP, 6 INCH, NON-NETWORK(4 EACH).	320772	CSPR68	
3	AS REQ.	FITTING, CONDUIT, PVC, SPACER, INTERMEDIATE, 6 INCH, NON-NETWORK(4 EACH).	320773	CSPR68	
4	AS REQ.	ROPE, FULL TAPE, 900 LB STRENGTH, PRELUBRICATED, (PER FOOT)	30768	FTAFES1	
5	AS REQ.	DUCT MARKER, BURIED, DEVICE, ELEK TUNED, RED, (EACH).	307381	ELECMKRC	
6	AS REQ.	CONDUIT WORKER MANDREL			

APPROVED BY



NO.	REVISION	BY	DATE

ADDISON TOWN OF ADDISON DALLAS COUNTY, TEXAS
PAVING, DRAINAGE & UTILITY IMPROVEMENTS
VITRUVIAN WAY EXTENSION

ELECTRICAL DUCT BANK DETAILS

PROJECT	DESIGN	DRAWN	DATE	FILE	SHEET
5029-01	ICE	ICE	OCT 01 2010	PW# 2010-02	30

PAVING, DRAINAGE, & UTILITY IMPROVEMENTS - VITRUVIAN WAY EXTENSION