

STORM DRAIN GENERAL NOTES

- REFER TO SHEET 3 "GENERAL CONSTRUCTION NOTES, LEGEND AND ABBREVIATIONS" FOR THE GENERAL CONSTRUCTION NOTES FOR THIS PROJECT.
- ALL WORK SHALL BE PERFORMED IN ACCORDANCE WITH STANDARD SPECIFICATIONS FOR STORM DRAINAGE CONSTRUCTION AS PUBLISHED BY NORTH CENTRAL TEXAS COUNCIL OF GOVERNMENTS, AND ANY AND ALL AMENDMENTS BY THE TOWN OF ADDISON, AS WELL AS STANDARD CONSTRUCTION DETAILS OF THE TOWN OF ADDISON.
- PRIOR TO COMMENCING CONSTRUCTION THE TOWN OF ADDISON, THE CONSULTING ENGINEERS, THE SUCCESSFUL CONTRACTOR, UTILITY COMPANIES, AND ANY OTHER AFFECTED PARTIES, SHALL CONVEENE FOR A PRE-CONSTRUCTION CONFERENCE AT LEAST 48 HOURS PRIOR TO THE BEGINNING OF CONSTRUCTION.
- THE CONTRACTOR SHALL OBTAIN A RIGHT-OF-WAY PERMIT FROM THE TOWN OF ADDISON PRIOR TO WORKING WITHIN THE PUBLIC RIGHT-OF-WAY.
- IT IS THE CONTRACTOR'S RESPONSIBILITY TO CONTACT ANY PUBLIC UTILITY COMPANIES FOR LOCATION OF EXISTING FACILITIES IN OR NEAR THE WORK AREAS. THESE INCLUDE, BUT ARE NOT LIMITED TO THE FOLLOWING:
 TOWN OF ADDISON (WATER, SEWER, SIGNALS) ATMOS ENERGY (GAS)
 ONCOR ELECTRIC DELIVERY VERIZON / MCI
 AT&T (SOUTHWESTERN BELL) TIME-WARNER CABLE
- THE CONTRACTOR SHALL PROVIDE SUBMITTALS TO THE ENGINEER (SIX SETS EACH), FOR APPROVAL OF ALL MATERIALS TO BE ADDED TO THE PUBLIC INFRASTRUCTURE, PRIOR TO INCORPORATING MATERIALS INTO THE JOB.
- THE CONTRACTOR SHALL PROVIDE AND SUBMIT TO THE TOWN OF ADDISON (SIX SETS EACH), AN APPROVED TRENCH SAFETY PLAN, SEALED BY A PROFESSIONAL ENGINEER REGISTERED IN THE STATE OF TEXAS, FOR THE INSTALLATION OF STORM DRAINAGE FACILITIES GREATER THAN FIVE (5) FEET IN DEPTH.
- THE CONTRACTOR SHALL FULLY COMPLY WITH, AND SUPPLEMENT AS NECESSARY, THE CONDITIONS OF THE STORM WATER POLLUTION PREVENTION PLAN WHILE CONDUCTING HIS ACTIVITIES ON THIS PROJECT.
- IT SHALL BE THE RESPONSIBILITY OF THE CONTRACTOR TO IMPLEMENT, AND SUPPLEMENT AS NECESSARY, THE TRAFFIC CONTROL MEASURES ON THIS PROJECT, INCLUDING PROVIDING ADEQUATE FLAGMEN, SIGNAGE, STRIPING AND WARNING DEVICES, ETC., DURING CONSTRUCTION IN ACCORDANCE WITH THE "TEXAS MANUAL OF UNIFORM CONTROL DEVICES". THE CONTRACTOR SHALL MAINTAIN AT LEAST ONE LANE OF TRAFFIC IN EACH DIRECTION DURING WORKING HOURS OR PROVIDE AN ALL-WEATHER DETOUR AROUND THE CONSTRUCTION SITE, INCLUDING PUBLIC NOTIFICATION AND SIGNAGE.
- THE TOWN OF ADDISON PUBLIC WORKS DEPARTMENT WILL APPROVE AND/OR DETERMINE THE TRAFFIC CONTROL PLAN AND WORKING HOURS. CONTACT THE ASSISTANT CITY ENGINEER OR THE PUBLIC WORKS INSPECTOR AT (972) 450-2871.
- TEMPORARY OR PERMANENT BARRICADES SHALL REMAIN AT ALL POINTS OF INGRESS OR EGRESS TO PREVENT PUBLIC USE UNTIL THE WORK RECEIVES FINAL ACCEPTANCE.
- THE CONTRACTOR SHALL BE RESPONSIBLE FOR MAINTAINING ADEQUATE DRAINAGE AT ALL TIMES DURING CONSTRUCTION, INCLUDING PROVIDING ALL TEMPORARY STRUCTURES OR IMPROVEMENTS AS NECESSARY FOR THE SAFETY OF THE PUBLIC.
- THE CONTRACTOR SHALL COVER ALL OPEN EXCAVATIONS WITH ANCHORED STEEL PLATING, DURING NON-WORKING HOURS, ALONG EXISTING ROADWAYS AND TRAFFIC AREAS.
- THE TOWN OF ADDISON WILL PROVIDE A GEOTECHNICAL LABORATORY TO PERFORM APPROPRIATE TESTING DURING CONSTRUCTION ACTIVITIES. ANY TEST THAT FAILS TO MEET CITY REQUIREMENTS SHALL BE RETESTED AT THE CONTRACTORS EXPENSE.
- THE CONTRACTOR SHALL PROVIDE A MAINTENANCE BOND FOR PUBLIC INFRASTRUCTURE WORK IN THE FOLLOWING AMOUNTS:
 • 100% FOR VALUATIONS LESS THAN OR EQUAL TO \$5,000.
 • \$5,000 FOR VALUATIONS GREATER THAN \$5,000 AND LESS THAN \$50,000.
 • 10% FOR VALUATIONS GREATER THAN \$50,000.
 BONDS SHALL BE FOR A PERIOD OF TWO YEARS BEGINNING WITH THE DATE OF FINAL ACCEPTANCE BY THE TOWN.
- THE CONTRACTOR SHALL VERIFY THE SIZE, TYPE, ELEVATION, CONFIGURATION, AND ANGLULATION OF EXISTING STORM DRAIN LINES PRIOR TO CONSTRUCTION OF TIE-IN MATERIALS. THE CONTRACTOR SHALL ASSUME RESPONSIBILITY FOR REPAIRS TO EXISTING FACILITIES DAMAGED BY HIS ACTIVITIES.
- THE CONTRACTOR SHALL MAKE NECESSARY PROVISIONS FOR THE SUPPORT AND PROTECTION OF ALL UTILITY POLES, FENCES, TREES, SHRUBS, GAS MAINS, TELEPHONE CABLES, ELECTRIC CABLES, DRAINAGE PIPES, UTILITY SERVICES, AND ALL OTHER UTILITIES AND STRUCTURES BOTH ABOVE AND BELOW THE GROUND, THE COST OF WHICH SHALL BE INCLUDED IN THE CONTRACT AMOUNT.
- ROUGH GRADING SHALL BE COMPLETED PRIOR TO CONSTRUCTION OF STORM DRAIN FACILITIES.
- ALL STORM DRAIN STRUCTURES INCLUDING MANHOLES, INLETS AND CLEANOUTS MUST BE ADJUSTED TO FINAL FINISHED GRADE BY THE CONTRACTOR.
- ALL PIPE FOR PUBLIC STORM DRAIN IMPROVEMENTS SHALL BE REINFORCED CONCRETE PIPE (RCP), CLASS III, UNLESS OTHERWISE NOTED. REINFORCED CONCRETE PIPE JOINTS SHALL BE SEALED WITH RAMNECK OR APPROVED EQUAL.
- ALL STORM SEWER SYSTEMS WITH RADII LESS THAN 100' SHALL UTILIZE 4' LONG PIPE JOINTS WITH BEVELED ENDS (R=2 RADIUS PIPE). ALL JOINTS MUST BE TIGHT AND SHALL NOT GAP MORE THAN 1/8" THE JOINT LENGTH.
- ALL PIPE ENTERING PUBLIC STORM DRAIN STRUCTURES SHALL BE GROUTED TO ASSURE WATERTIGHT CONNECTIONS.
- EMBEDMENT FOR STORM DRAIN PIPING SHALL CONSIST OF GRADE 4 CRUSHED STONE (3" BELOW PIPE FOR 27" AND SMALLER PIPES, AND 4" BELOW PIPE FOR 30" PIPES AND LARGER) TO THE CRADLE OF THE PIPE, WITH SELECT NATIVE SOIL LESS THAN 3" IN DIAMETER OR GRANULAR MATERIAL TO 6" OVER THE TOP OF PIPE.
- FINISH BACKFILL SHALL BE NATIVE SOIL FREE OF ALL ROCKS AND CLODS GREATER THAN THREE INCHES IN DIAMETER, COMPACTED TO 95% STANDARD PROCTOR DENSITY, IN SIX (6) INCH MAXIMUM LOOSE LIFTS, WITH ZERO TO PLUS THREE, OPTIMUM MOISTURE.
- CONCRETE COLLARS SHALL BE INSTALLED AT ALL CHANGES IN CONDUIT SIZE AND AT ALL JOINTS THAT ARE PULLED IN EXCESS OF THAT RECOMMENDED BY THE CONDUIT MANUFACTURER.
- THE CONTRACTOR SHALL COMPLETELY REMOVE AND DISPOSE OF EXISTING STORM DRAIN FACILITIES, DESIGNATED TO BE REMOVED, UPON COMPLETION AND ACCEPTANCE OF NEW STORM DRAINAGE FACILITIES.
- ALL STORM DRAIN PIPE SHALL BE CAMERA INSPECTED BY THE CONTRACTOR AFTER THE INSTALLATION OF ALL UTILITIES AND PRIOR TO FINAL ACCEPTANCE OF THE PROJECT.
- THE CONTRACTOR SHALL CALL (972) 450-2847 TO REQUEST A FINAL WALK-THROUGH INSPECTION OF THE PUBLIC INFRASTRUCTURE WORK.
- ANY ADJACENT PROPERTIES AFFECTED BY THE CONSTRUCTION SHALL BE RESTORED TO PRE-CONSTRUCTION CONDITIONS, OR BETTER.

REINFORCING STEEL SCHEDULE
DIMENSIONS ARE FOR MAXIMUM SIZE INLETS

INLET LENGTH	BAR TYPE	BAR (1/8")	NO. REQ'D.	BAR DIMENSIONS			INLET LENGTH	BAR TYPE	BAR (1/8")	NO. REQ'D.	BAR DIMENSIONS		
				A	B	C					A	B	C
6'	A	3	15	3'-2"	0'-6"	-	8'	A	3	19	3'-2"	0'-6"	-
	B	3	2	11'-6"	-	-		B	3	2	19'-6"	-	-
	C	4	16	13'-4"	0'-6"	-		C	4	16	17'-4"	0'-6"	-
	D	4	9	4'-8"	-	-		D	4	9	4'-8"	-	-
	E	5	6	13'-4"	-	-		E	5	6	17'-4"	-	-
	F	4	5	1'-2"	-	-		F	4	5	1'-2"	-	-
7'	G	3	12	2'-0"	1'-3"	-	G	3	12	2'-0"	1'-3"	-	
	H	3	26	-	-	-	H	3	26	-	-	-	
	I	4	12	4'-8"	3'-2"	3'-2"	I	4	16	4'-8"	3'-2"	3'-2"	
	J	5	1	-	-	-	J	5	1	-	-	-	
	K	5	6	3'-2"	0'-6"	-	K	5	6	3'-2"	0'-6"	-	
	L	4	11	3'-2"	0'-6"	-	L	4	11	3'-2"	0'-6"	-	
10'	M	4	2	3'-0"	-	-	M	4	2	3'-0"	-	-	
	N	4	2	4'-8"	3'-2"	4'-8"	N	4	2	4'-8"	3'-2"	4'-8"	
	A	3	17	3'-2"	0'-6"	-	A	3	23	3'-2"	0'-6"	-	
	B	3	2	19'-6"	-	-	B	3	2	19'-6"	-	-	
	C	4	16	15'-4"	0'-6"	-	C	4	16	21'-4"	0'-6"	-	
	D	4	9	4'-8"	-	-	D	4	9	4'-8"	-	-	
10'	E	5	6	15'-4"	-	-	E	5	6	21'-4"	-	-	
	F	4	5	1'-2"	-	-	F	4	5	1'-2"	-	-	
	G	3	15	2'-0"	1'-3"	-	G	3	15	2'-0"	1'-3"	-	
	H	3	32	-	-	-	H	3	32	-	-	-	
	I	4	14	4'-8"	3'-2"	3'-2"	I	4	20	4'-8"	3'-2"	3'-2"	
	J	5	1	-	-	-	J	5	1	-	-	-	
10'	K	5	6	3'-2"	0'-6"	-	K	5	6	3'-2"	0'-6"	-	
	L	4	11	3'-2"	0'-6"	-	L	4	11	3'-2"	0'-6"	-	
	M	4	2	3'-0"	-	-	M	4	2	3'-0"	-	-	
	N	4	2	4'-8"	3'-2"	4'-8"	N	4	2	4'-8"	3'-2"	4'-8"	

* SEE DIAGRAM FOR DIMENSION
** FIELD CUT AS REQUIRED TO ACCOMMODATE DRAIN PIPE

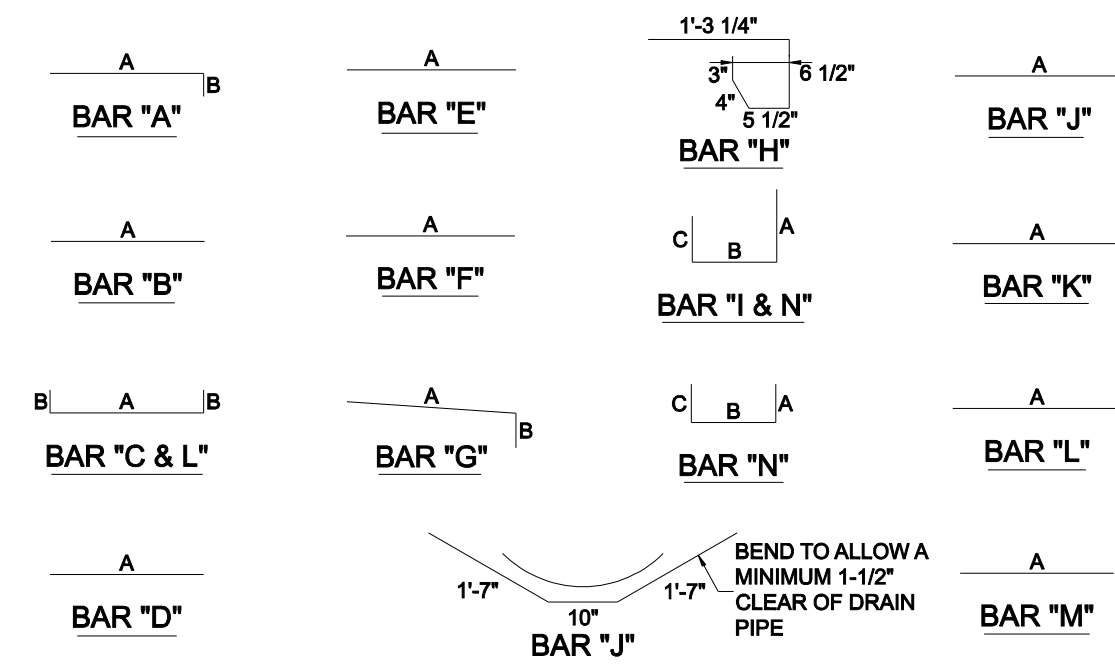

BAR DIAGRAMS

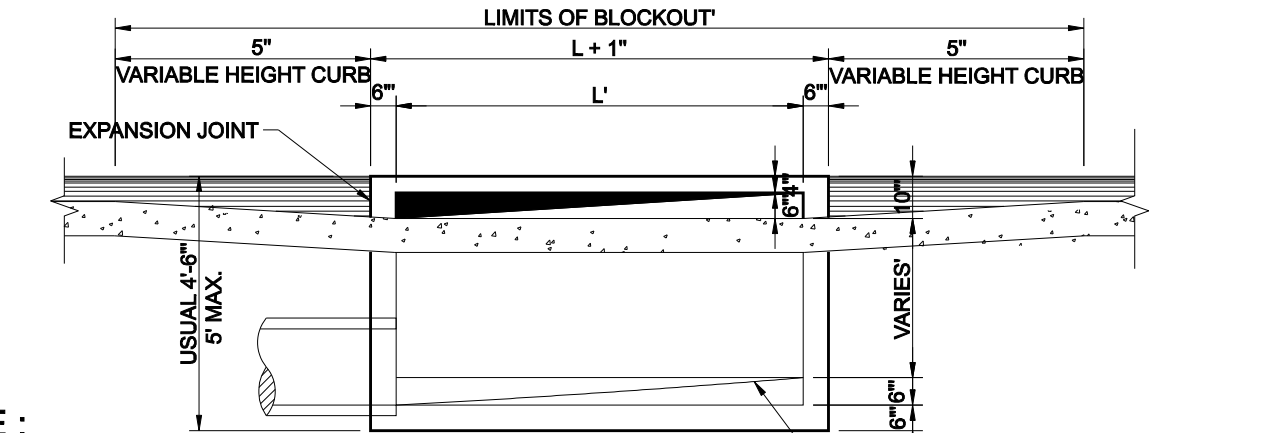
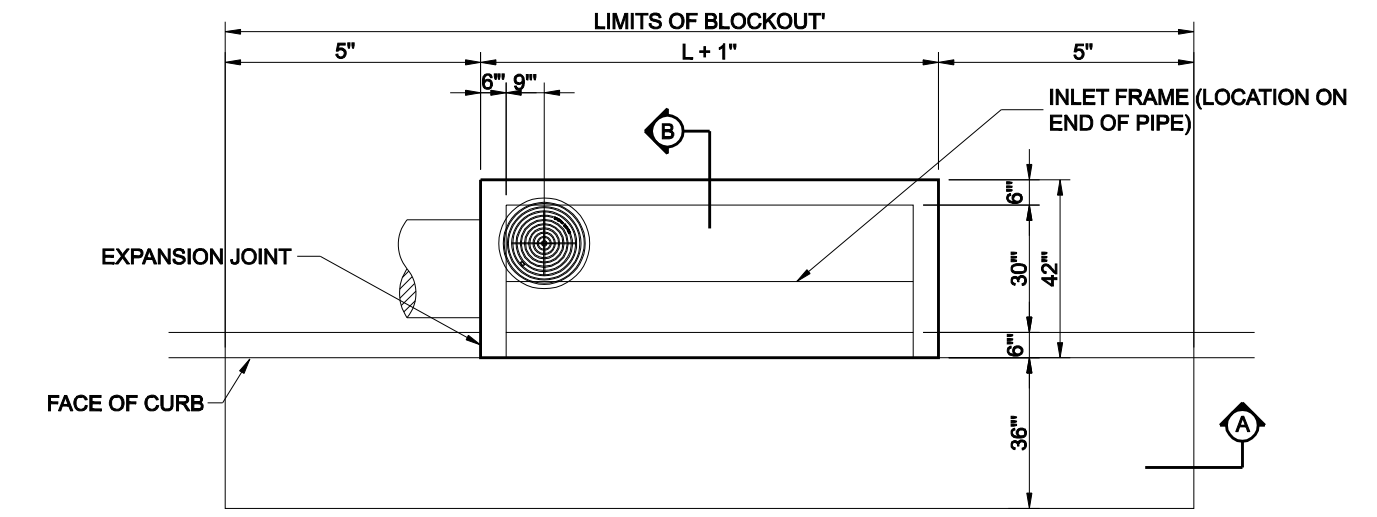

NOTE:
PIPE MAY BE PLACED IN ANY WALL, BUT SHALL NOT ENTER ANY CORNER OR BOTTOM.

#3 BAR 18" O.C.E.W. IN BLOCK OUT DRILLED INTO EXISTING CONCRETE.

STANDARD CURB INLET
6, 8 AND 10 FOOT
N.T.S.

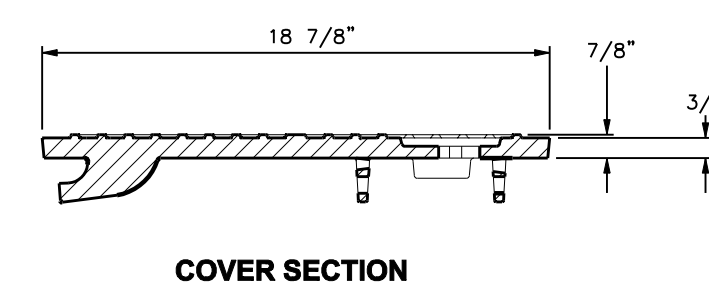
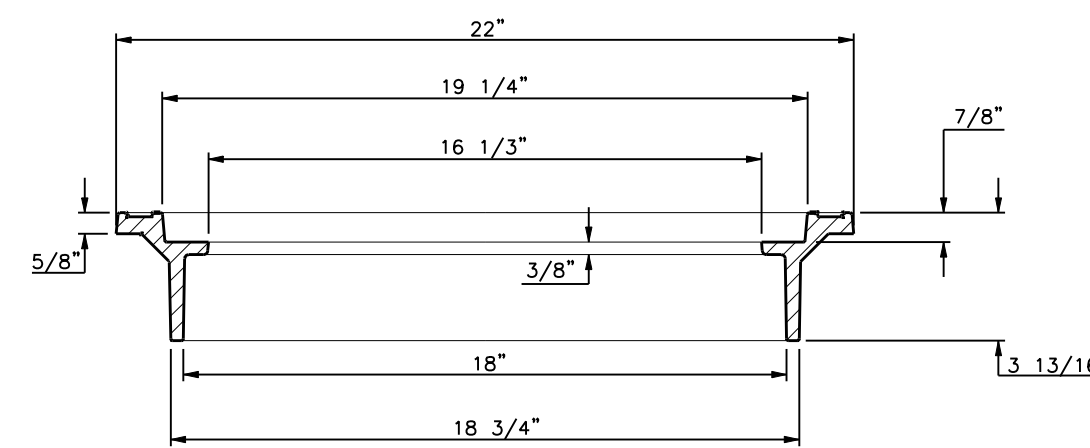
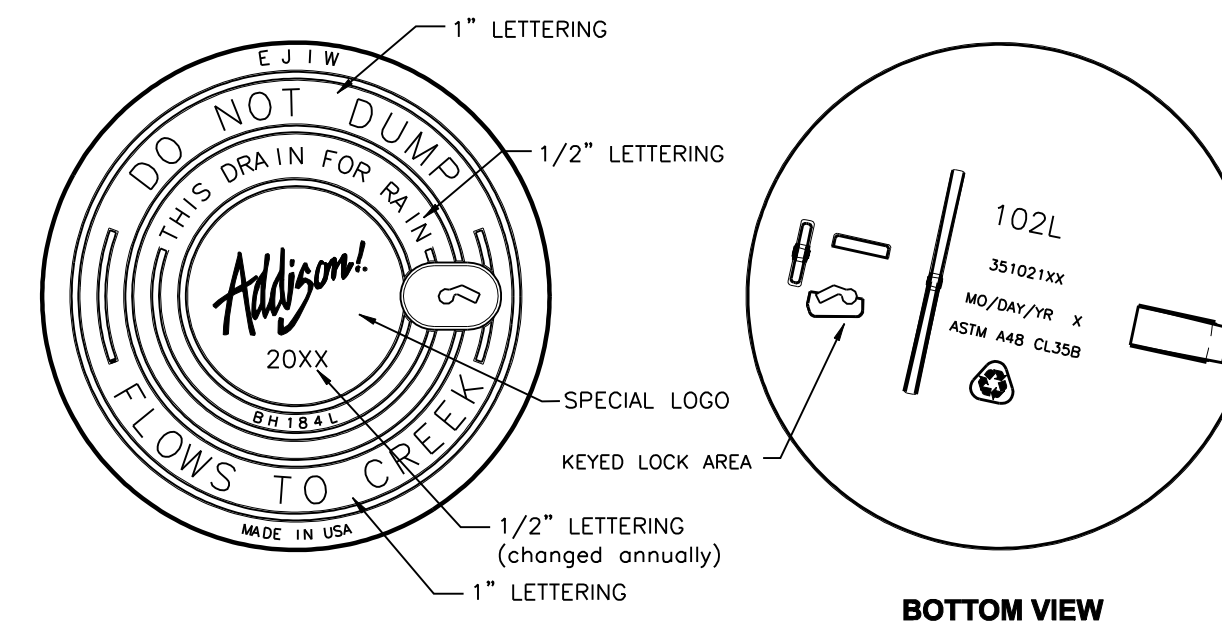
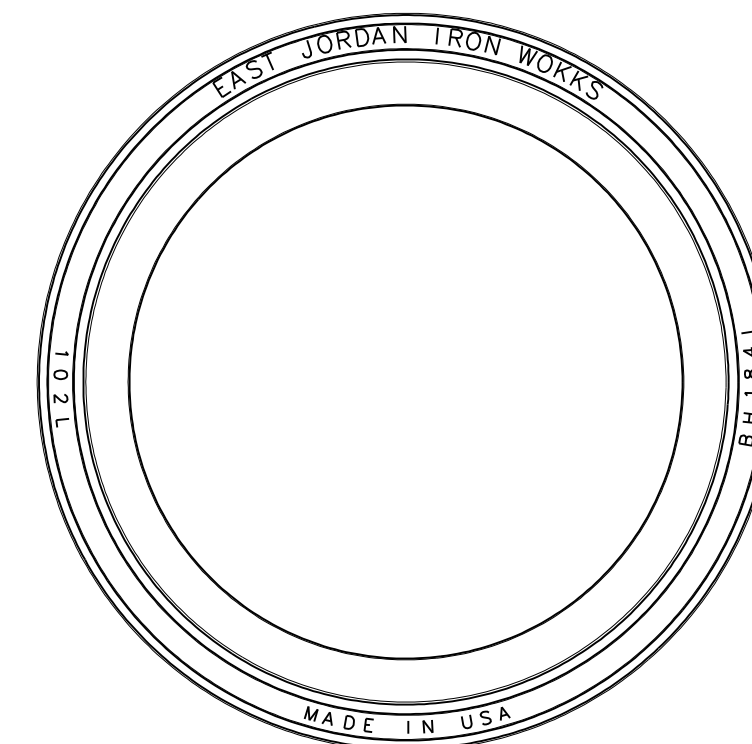

RING SECTION

COVER SECTION

LOAD RATING LIGHT DUTY INLET COVER NON-Traffic INLET RING	COATING DIPPED	ESTIMATED WEIGHT COVER: 60 LBS FRAME: 151 LBS	MATERIAL SPECIFICATION COVER - GRAY IRON ASTM A48 CL35B FRAME - GRAY IRON ASTM A48 CL35B
-----------------------------------------------------------------------	-------------------	-----------------------------------------------------	------------------------------------------------------------------------------------------------------

↓ DESIGNATES MACHINE SURFACE

INLET FRAME AND COVER

GENERAL NOTES

- ALL CONCRETE DRAINAGE STRUCTURES SHALL HAVE A MINIMUM COMPRESSED STRENGTH OF 3600 P.S.I.
- ALL CRUSHED STONE SHALL BE 3/4", PASSING #4 SIEVE.
- ALL FIELD JOINTS WILL BE APPROVED BY THE CITY ENGINEER IF NECESSARY. FIELD JOINTS SHALL BE WIPED ON THE INSIDE AND OUTSIDE TO PROVIDE FOR SMOOTH FLOW OF WATER.
- RAMNECK COMPOUND OR APPROVED EQUAL SHALL BE USED FOR JOINT SEALS.
- ALL STORM SEWER PIPE SHALL BE CAMERA INSPECTED AFTER THE INSTALLATION OF ALL PAVING, UTILITIES, AND PRIOR TO FINAL ACCEPTANCE OF THE PROJECT.



NO.	REVISION	BY	DATE

Addison! TOWN OF ADDISON
DALLAS COUNTY, TEXAS

PAVING, DRAINAGE & UTILITY IMPROVEMENTS
PONTE AVENUE CIRCLE

STORM DRAIN DETAILS & GENERAL NOTES

icon Consulting Engineers, Inc.		250 W. Southlake Blvd., Suite 117	
Civil Engineers - Designers - Planners		Southlake, Tx 76092 (817) 552-6210	
PROJECT	DESIGN	DRAWN	DATE
5019-09	ICE	ICE	SEPT 22, 2011
FILE	SHEET		
PW# 2011-03	14		

PAVING, DRAINAGE, & UTILITY IMPROVEMENTS - PONTE AVENUE CIRCLE