

DISCLAIMER: The use of this standard is governed by the "Texas Engineering Practice Act". No warranty of any kind is made by TxDOT for any purpose whatsoever. TxDOT assumes no responsibility for the conversion of this standard to other formats or for incorrect results or damages resulting from its use.

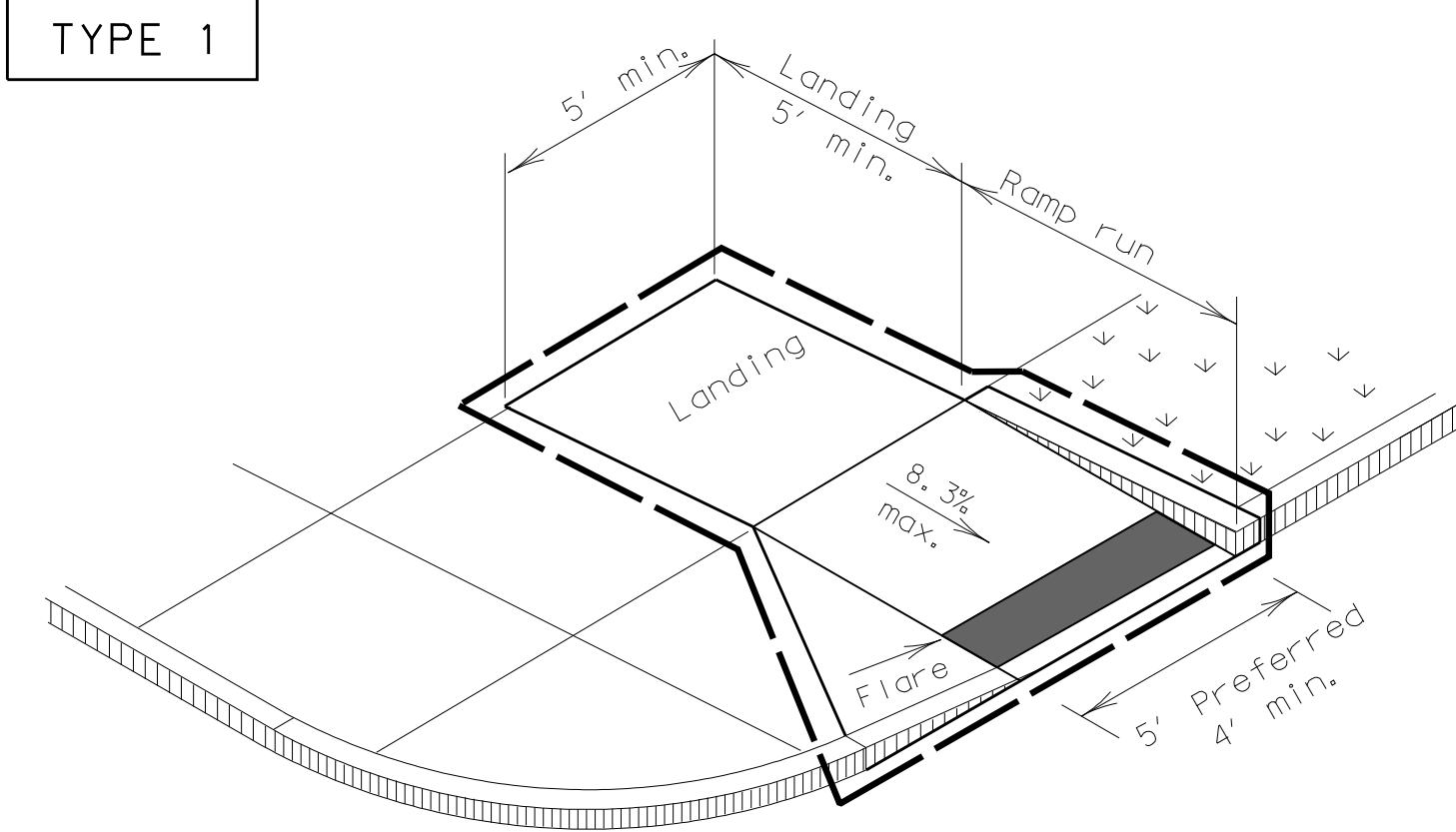

PERPENDICULAR CURB RAMP

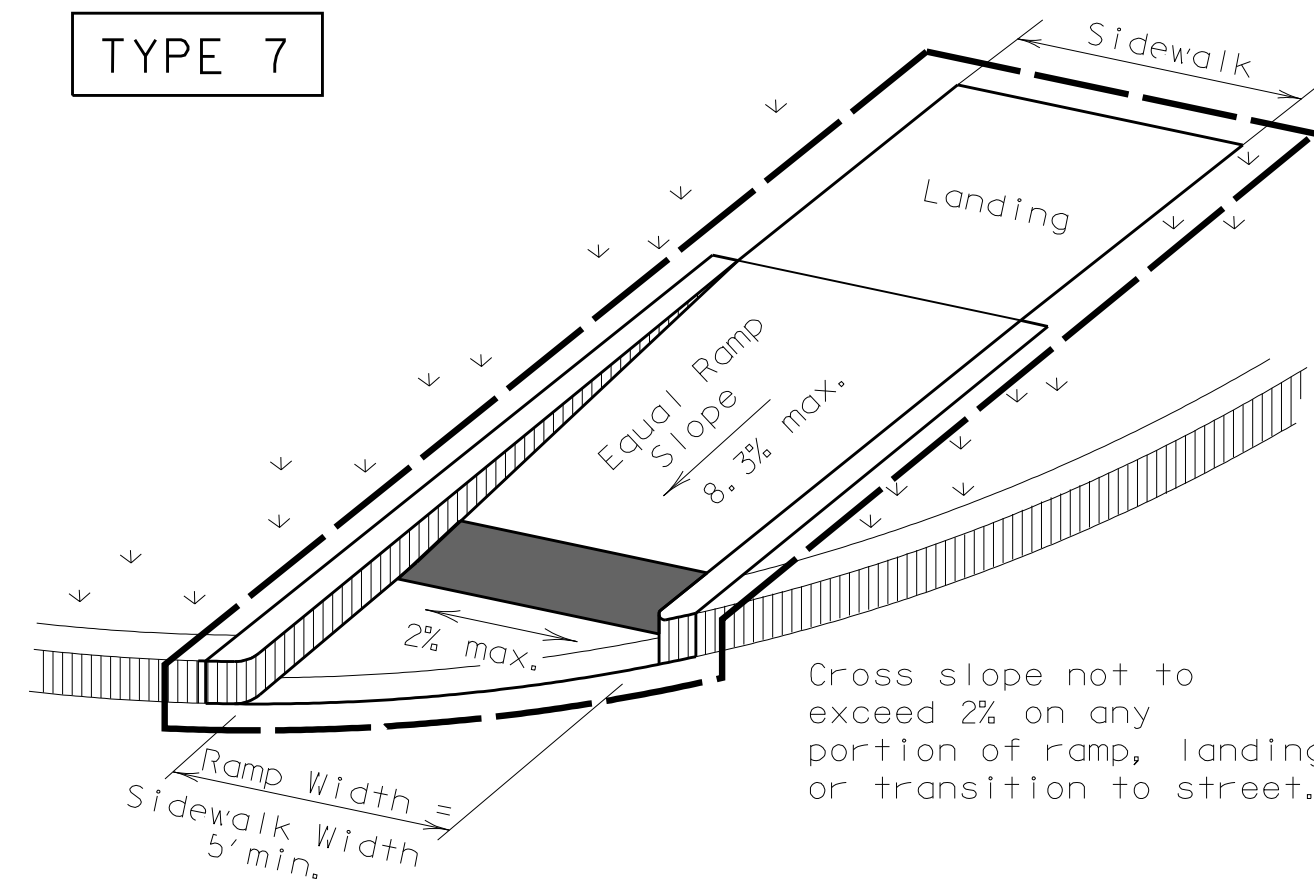

(Sidewalk set back from curb)

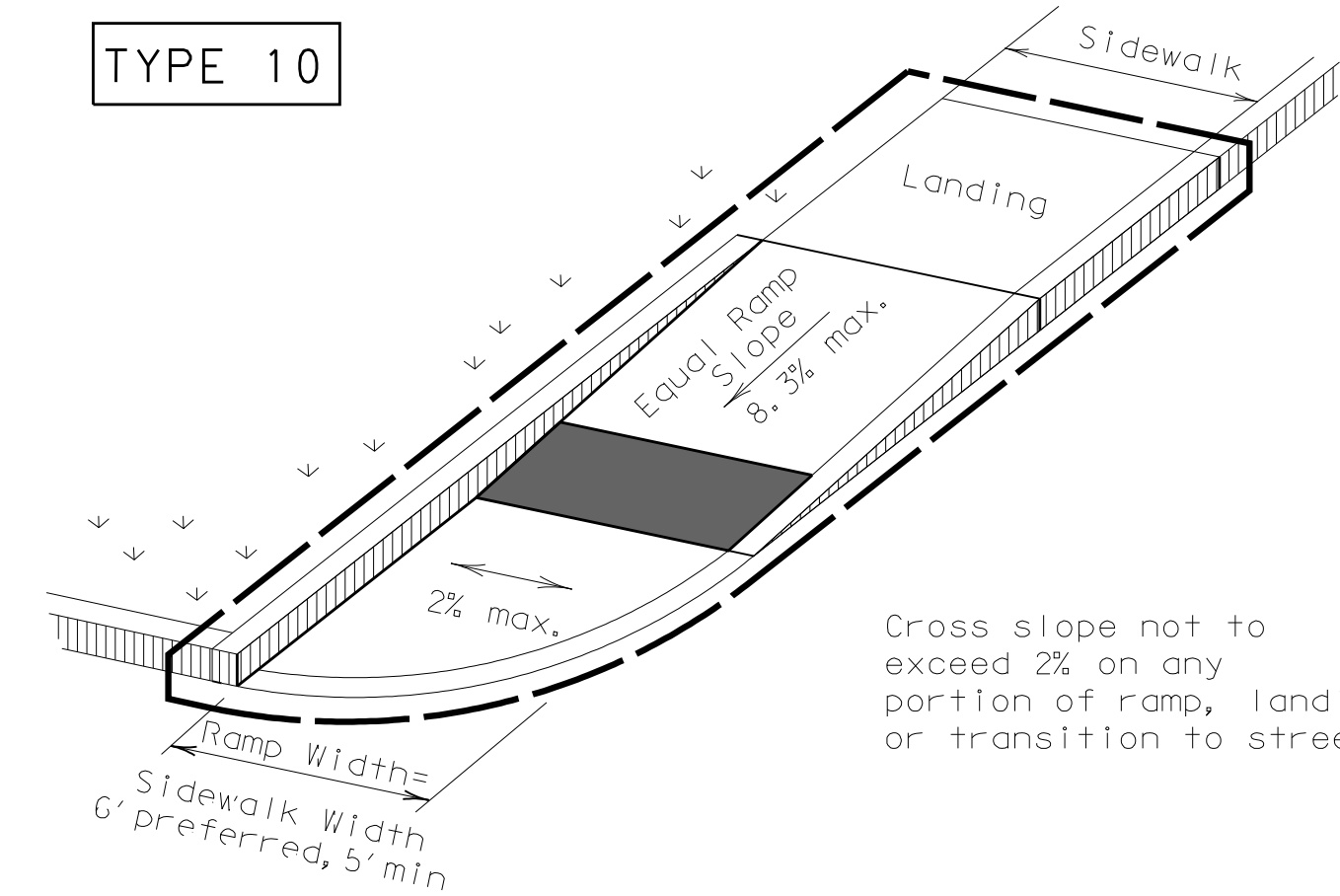

(Sidewalk adjacent to curb)

DIRECTIONAL RAMPS WITHIN RADIUS

Install detectable warning surface at each end of cut-through ramp with minimum 2' smooth surface between. If median is less than 6' wide, eliminate detectable warning surfaces.

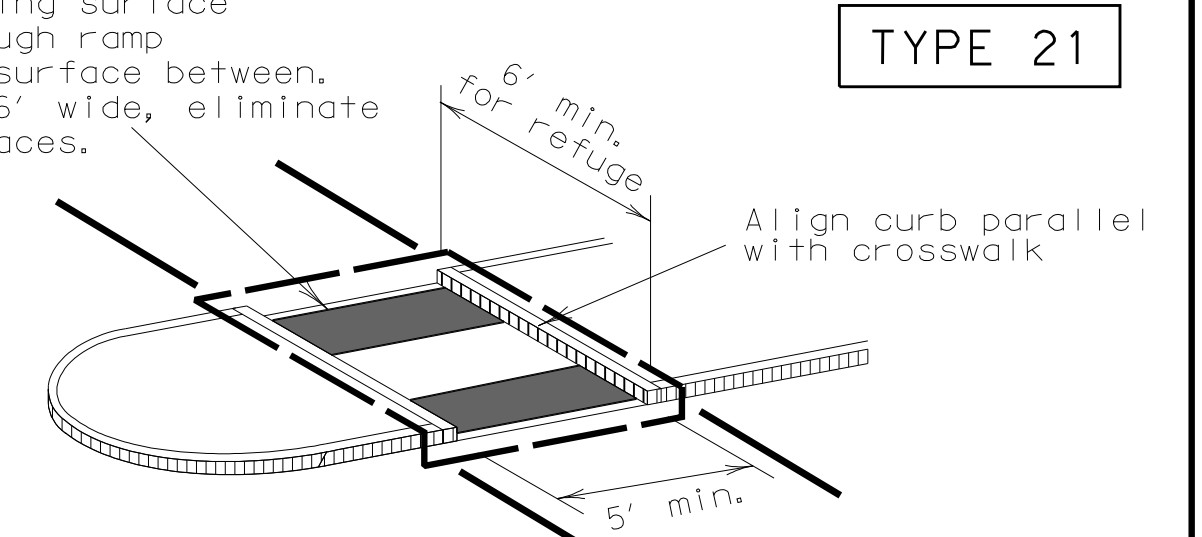

Curb details are shown elsewhere in the plans.

CURB RAMPS AT MEDIAN ISLANDS

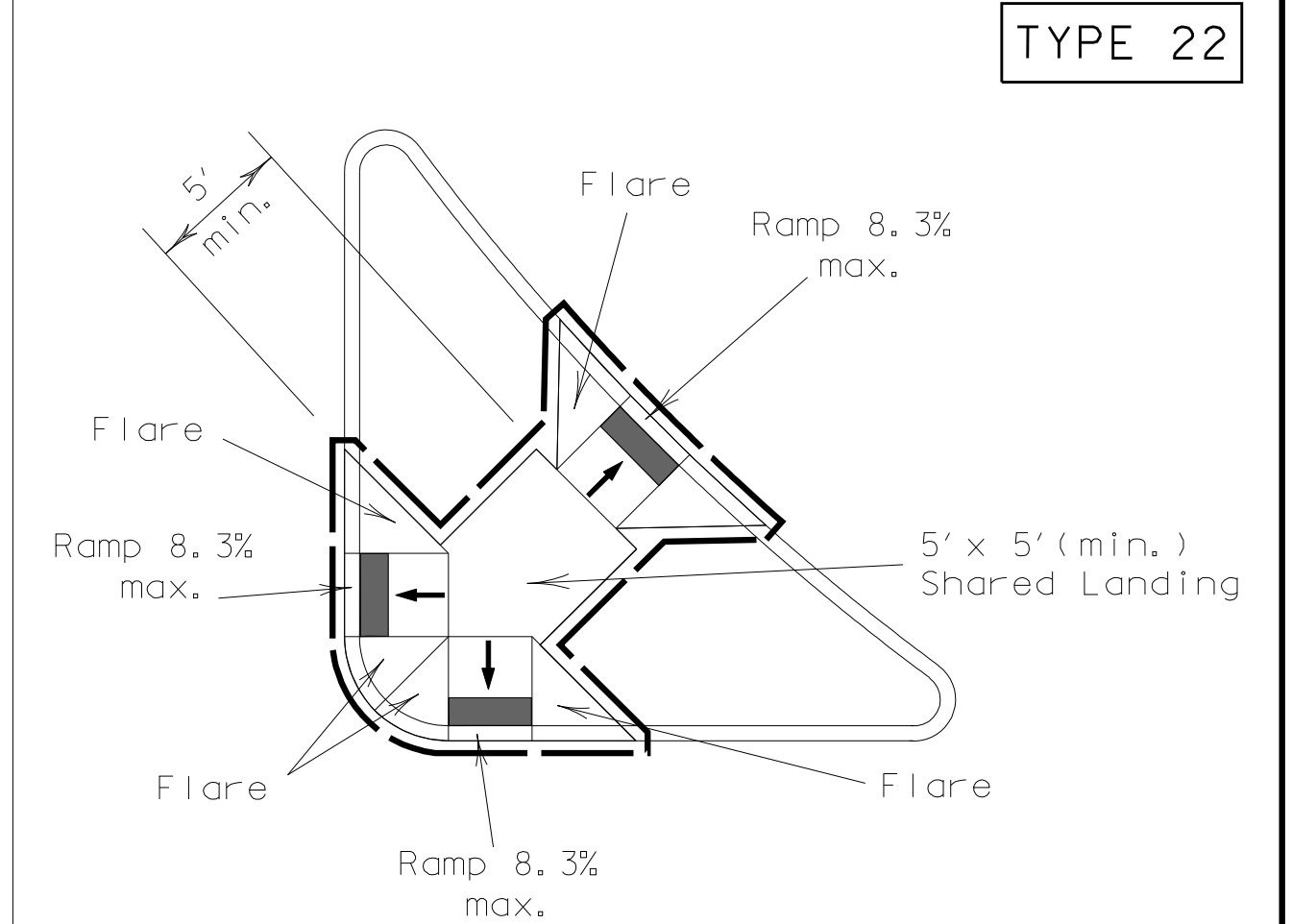

COMBINATION ISLAND RAMPS

NOTES / LEGEND:

See General Notes on sheet 2 of 4 for more information.

- ∨ ∨ ∨ Denotes planting or non-walking surface not part of pedestrian circulation path.

- Ramp Limits of Payment
- Detectable Warning Surface

SHEET 1 OF 4



PEDESTRIAN FACILITIES  
CURB RAMPS

PED-12A

FILE: ped12a.dgn	DN: TxDOT	CK: RM	DW: TxDOT	CK: VP
© TxDOT March 2002	CONT	SECT	JOB	HIGHWAY
REVISIONS				
VP June 13, 2012	DIST	COUNTY	SHEET NO.	
			16	