

I. ELECTRICAL CONDUCTORS

A. MATERIALS

- Insulated conductors shall be NEC Type XHHW. Insulated conductors shall be color coded in accordance with the NEC, articles 200, 250, and 310; i.e. insulation of grounded conductors (neutrals) shall be white. Grounding conductors (ground wires) shall be bare or insulation shall be green. Insulation of ungrounded conductors (hots) shall be any color except green, white, or gray. Identification of conductors #6 American Wire Gauge (AWG) and smaller shall be by continuous jacket color. Color coding of electrical conductors #4 AWG and larger shall be either by continuous color jacket or by colored tape. Colored tape marker shall consist of a half-lap of tape covering a 6-inch length of conductor.
- Where two or more circuits are present in one conduit or enclosure, the conductors of each circuit shall be identified by a permanent non-metallic tag at each accessible location. The tag shall be fastened to the conductors by two plastic straps. Each tag shall indicate circuit number, letter, or other identification shown in the plans.
- Grounding electrode conductor #6 AWG for bonding to ground rod at electrical service, shall be solid. Connection of conductor to ground rod shall be made using UL Listed connectors designed for such purposes.
- Heat Shrink Tape filler shall be used to seal the ends of heat shrink tubing around two or more conductors that are insulated with heat shrink tubing. Tape material shall have a minimum dielectric strength of 225 volts per mil and shall be cross-linked butyl rubber. Tape shall be supplied in rolls and shall have a backing (release paper) to prevent the tape from sticking to itself.
- Heat shrink tubing shall be heavy wall, UL listed for 600 volts or greater and shall have factory applied internal sealant.
- GelCaps shall be UL listed for 600-volt applications. GelCap shall have see-through elastomer molded cover. Cover shall be filled with high dielectric insulating gel silicone sealant to provide water-seal. Cover shall be held in place by snap-lock, molded clamp made of UV stable polypropylene.
- Splicing materials, insulating materials, breakaway disconnects, GelCaps and fuse holders will not be paid for directly but shall be subsidiary to various bid items.

B. CONSTRUCTION METHODS

- After conductors have been installed in conduit, a pull test shall be made on conductors. When any length of conductor cannot be freely pulled, the Contractor shall make any needed alterations or repairs at no expense to the State.
- The Contractor shall perform insulation resistance tests in accordance with Item 620, "Electrical Conductors." The Contractor shall coordinate with the Engineer to witness the tests.
- A sufficient length of conductor for making up connections shall be left in ground boxes (2 feet minimum, 3 feet maximum, to point of splice, 3 feet minimum, 4 feet maximum, when conductor is pulled through with no splice), enclosures, weatherheads and pole bases (1 foot minimum, 1.5 feet maximum).
- Splices shall be made only in junction boxes, ground boxes, pole bases, or electrical enclosures and shall be made with listed compression or screw type pressure connectors, terminal blocks, bolted lugs, or split bolt connectors. Splices shall be insulated with heavy wall heat shrink tubing or GelCaps and shall be made so as to provide a watertight splice. Heat shrink sleeve shall overlap conductor insulation a minimum of 2 inches on both sides of the splice. Where heat shrink tubing may not shrink sufficiently to provide a watertight seal around the individual conductors, prior to heating the tubing, the Contractor shall increase the diameter of the conductors insulation using heat shrink filler tape to provide a watertight seal between the individual conductors and the heat shrink tubing. Tape shall be visible after completion of all splices. Where filler tape is used but not visible, the Engineer shall approve each individual splice by conducting a physical inspection of each splice. When it appears the tubing has been burned, or overheated the tubing shall be considered to be defective and shall be replaced.
- GelCaps when used in place of heat shrink method of splicing, shall be sized and installed according to manufacturer's specifications. (Raychem GelCap and GelCap SL or equal.)
- Wire nuts may be used for #8 AWG or smaller conductors in above-ground junction boxes, but not in pole bases or ground boxes. Wire nuts shall be positioned upright to prevent the accumulation of water. Wire nuts used at these locations shall have factory applied waterproof sealant.
- Conductors in illumination poles shall be supported by a J-hook in the top of the pole.
- All conductors bid under Item 620 "Electrical Conductors" shall have breakaway electrical disconnects installed anytime conductors pass through a break-away support device.
- For terminating the conductors, insulation-jacketing material shall be removed in such a manner as to not nick any of the individual strands of the conductor. When individual conductor strands are removed, the conductor shall be considered to be damaged.
- When a conductor or cable has been damaged, or fails to pass an insulation resistance test, the conductor shall be replaced.
- Duct tape, black electrical tape, or wire nuts shall not be used in the repair of a damaged conductor.
- For terminations, no more than one wire may be installed under a single pressure connector, unless the device is listed for more than one wire.
- Conductors connected to break-away in line fuse holders must be installed in accordance with the specific manufacturer's installation instructions. Where threaded connections are made, they shall be properly torqued. Where crimp type connections are made, crimps shall be made using properly sized crimping pliers. Proper conductor terminations are critical to the safe operation of break-away devices.
- Waterproofing boots shall be properly trimmed to fit snugly around the conductor so as to provide a water proof connection. No more than one wire may enter a single opening in any one boot. Water proofing boots must provide the correct number of openings. Where only one wire is to be connected to a boot, the boot may not be a two wire type.

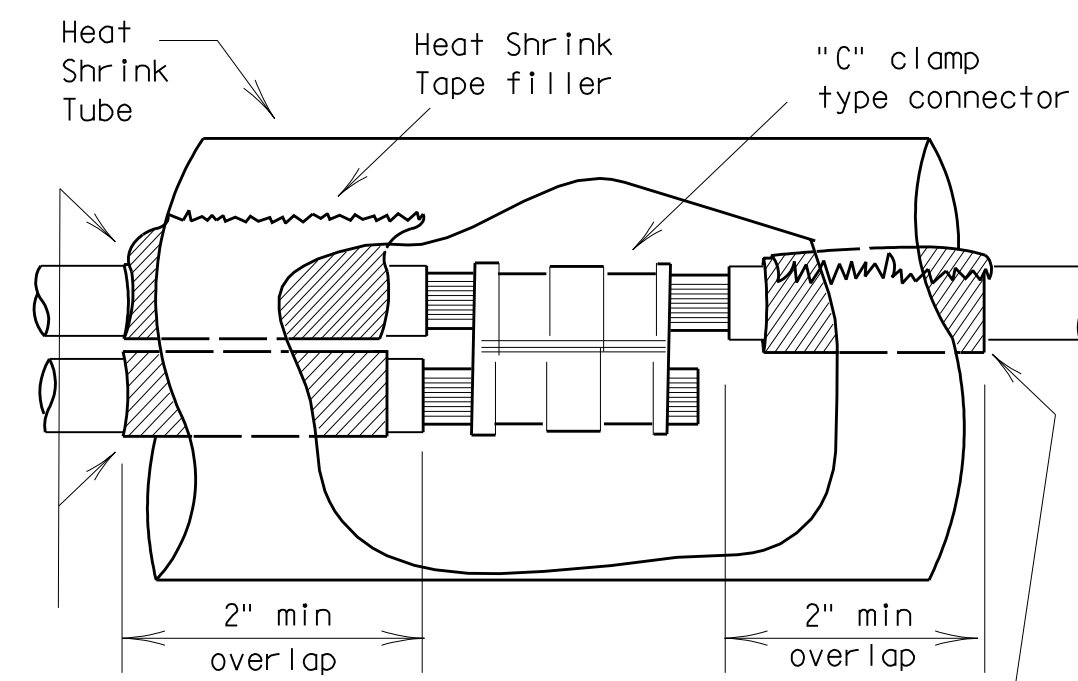

Seal between conductors with heat shrink tape. Tape to extend past end of tubing by 1/8" to 1/4".

Increase insulation diameter with heat shrink tape if necessary. Tape to extend past end of tubing by 1/8" to 1/4".

**SPLICE OPTION 1**  
C-CLAMP

Stainless steel or brass machine screw, nut, 2 flat washers, lock washer or self locking nut. Machine screw to be a min. of 10-24, 3/16 or the same size as the mounting hole provided by the manufacturer. Secure wrench tight. Movement of lugs after final assembly shall be considered to be a defective connection.

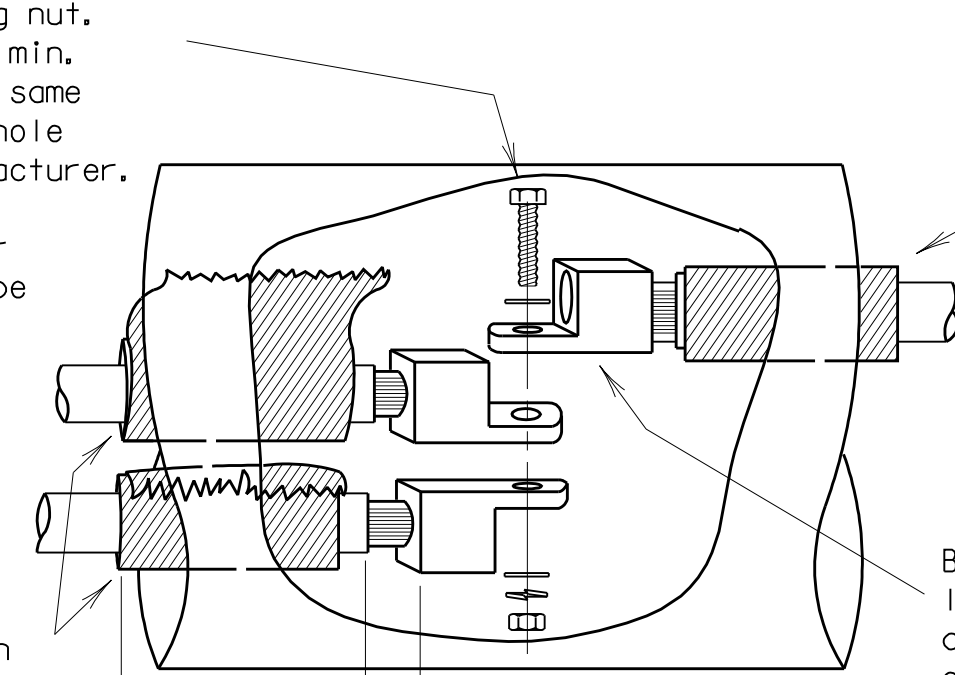

Seal between conductors with heat shrink tape. Tape to extend past end of tubing by 1/8" to 1/4".

Increase insulation diameter with heat shrink tape if necessary. Tape to extend past end of tubing by 1/8" to 1/4".

2" min overlap of heat shrink over wire insulation

Heat Shrink Tube

**SPLICE OPTION 2**  
BOLTED WIRE LUGS

**SPLICE OPTION 3**  
SPLIT BOLT

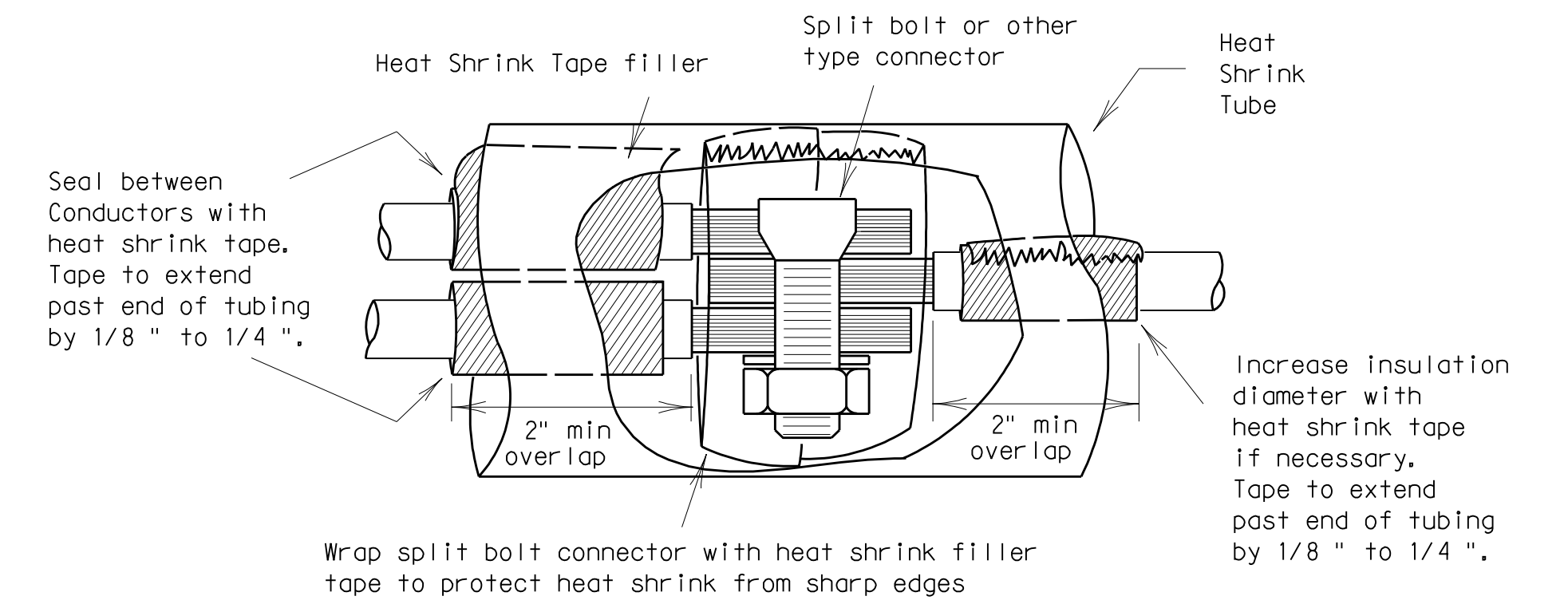

Seal between conductors with heat shrink tape. Tape to extend past end of tubing by 1/8" to 1/4".

Increase insulation diameter with heat shrink tape if necessary. Tape to extend past end of tubing by 1/8" to 1/4".

Wrap split bolt connector with heat shrink filler tape to protect heat shrink from sharp edges

**SPLICE OPTION 4**  
GELCAP

GelCap shall be sized and installed according to manufacturers specifications

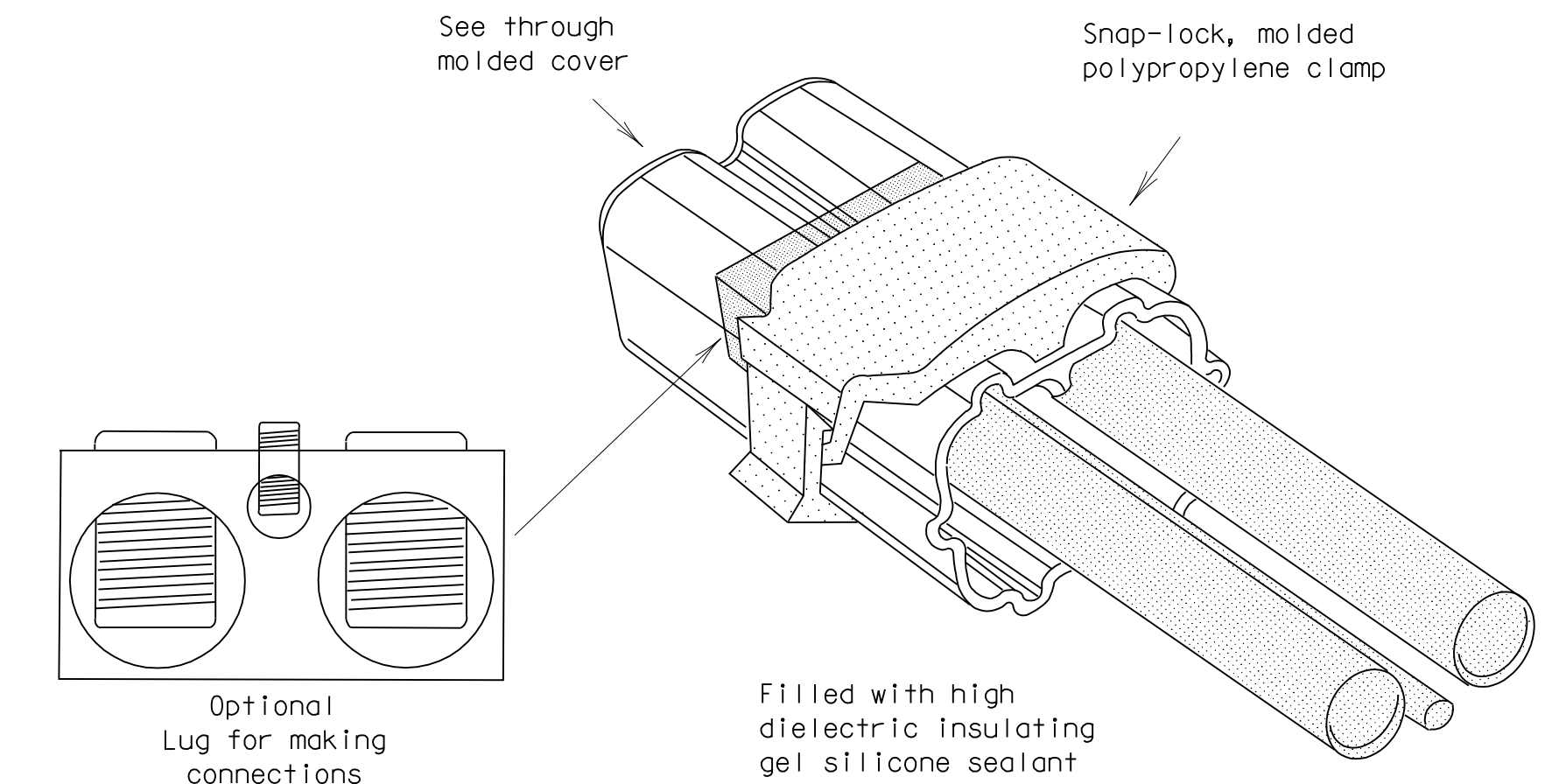

Optional Lug for making connections

Filled with high dielectric insulating gel silicone sealant

- All conduits that contain circuit wiring of 50 volts or more shall contain an equipment grounding conductor (EGC). Conduit for traffic signals shall have an EGC, with a minimum size of #8 AWG stranded. Unless otherwise shown on the plans, the EGC for all other conduits shall be the same AWG size as the largest current carrying conductor contained in that conduit. The EGC shall be paid for Item 620-Electrical Conductors.

C. TEMPORARY WIRING

- Temporary conductors and electrical equipment to provide power for utilization equipment, shall be installed in accordance with the NEC article 305. All temporary wiring materials and methods shall comply with the standard sheets. All power outlets for portable electrical equipment, power tools, ice machines, ice storage bins and refrigerators located outdoors at grade, supplied from a utility power source, shall be provided with a ground fault circuit interrupter.
- Residual current protective devices (GFCI) may be any one of the following: molded cord and plug set, receptacle, or circuit breaker type.
- Where wire nuts are approved for temporary wiring, they shall be of the self-sealing type.
- All conductor splices must be contained within a listed enclosure, ground box or the splices will be more than ten feet above grade vertically and more than five feet horizontally from any metal structure. Where temporary conductors are installed in any area that is likely to be subjected to vehicle traffic, or mobile construction equipment, the vertical clearance to ground shall be at least 18 feet when measured at the lowest point. Where power conductors are to be supported by a span wire, the span wire shall be properly grounded.
- Existing conduit containing service conductors uncovered during the construction process shall be repaired in a timely manner in accordance with the NEC. Existing non-metallic conduit exposed during construction shall not be left exposed above grade, or with less than eighteen inches of cover, without protective methods approved by the Engineer.

STANDARD PLANS  
TEXAS DEPARTMENT OF TRANSPORTATION  
Traffic Operations Division

**ELECTRICAL DETAILS-  
CONDUCTORS**

ED(2)-03

© TxDOT January 1992	DN-KB	CK-JW	DN-DN	CK-GC	NEG NO. 1
REVISIONS	STATE DISTRICT	FEDERAL REGION	FEDERAL AID PROJECT		
10-93		6			
4-98			COUNTY	CONTROL	SECTION
12-00					JOB
3-03					HIGHWAY