

**EXPANSION / ISOLATION JOINT**  
NOT TO SCALE

**EXPANSION / ISOLATION JOINT SEALANT**  
NOT TO SCALE

**STREET PAVERS ON CONCRETE DROP SLAB**  
NOT TO SCALE

**TYPICAL STREETSCAPE PLAN - VITRUVIAN WAY**  
SCALE: 1\"/>

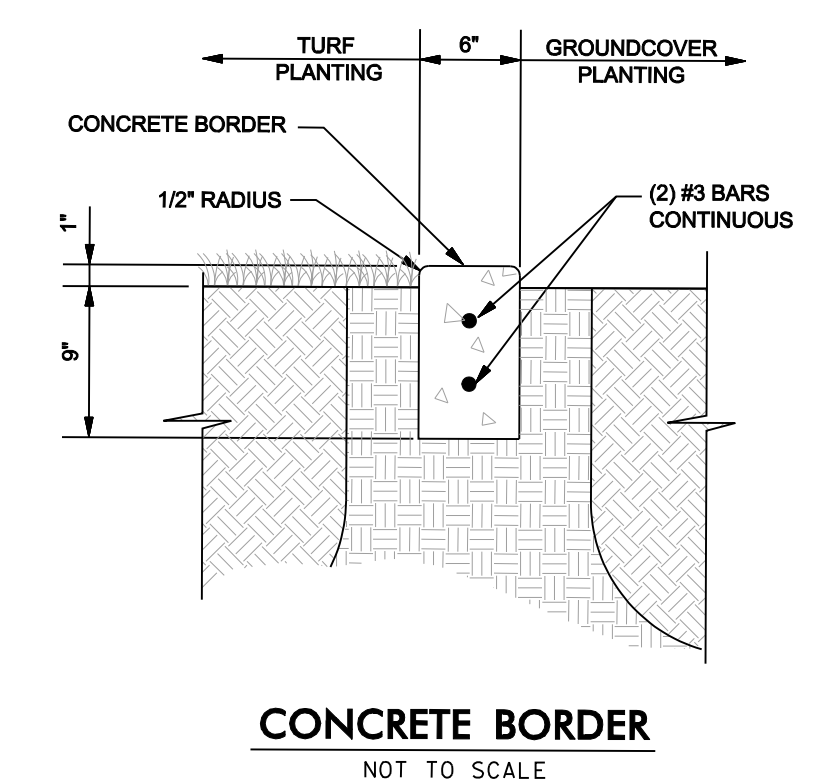
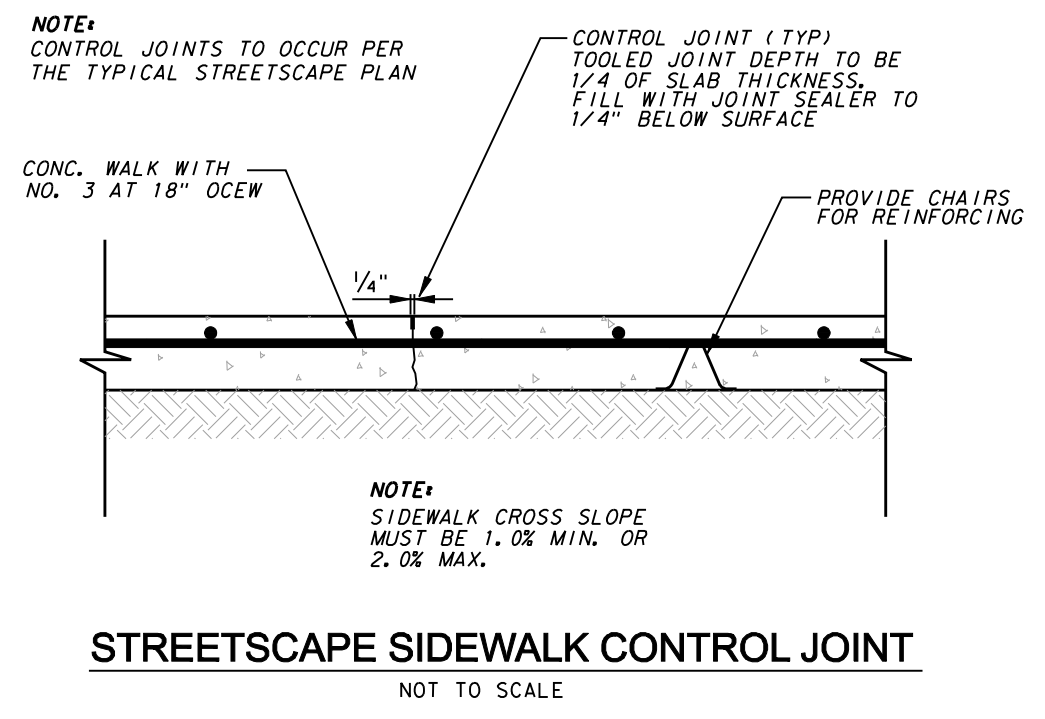
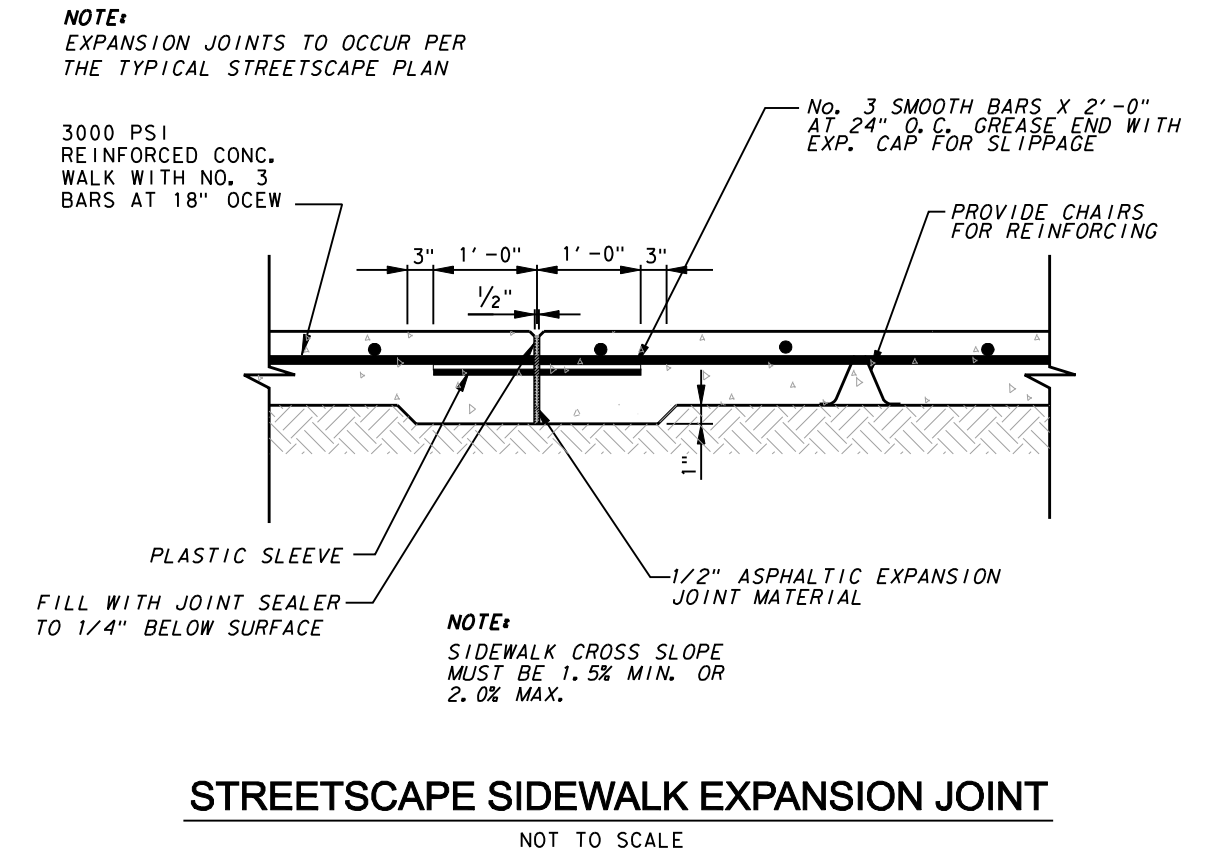
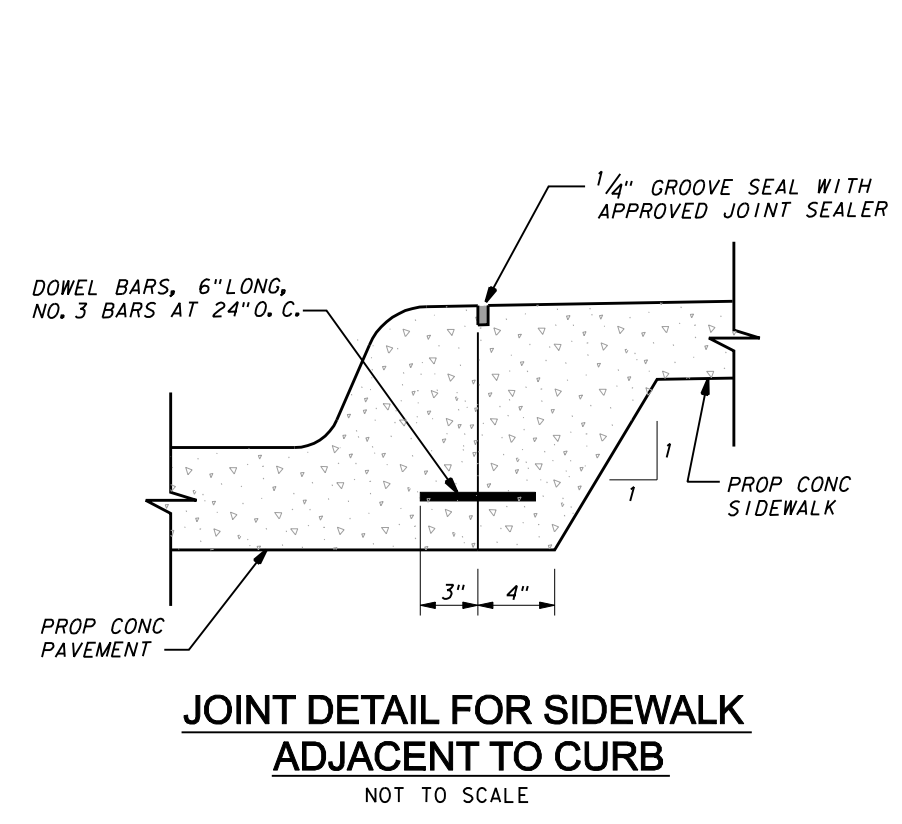

**JOINT DETAIL FOR SIDEWALK ADJACENT TO CURB**  
NOT TO SCALE

**STREETSCAPE SIDEWALK EXPANSION JOINT**  
NOT TO SCALE

**STREETSCAPE SIDEWALK CONTROL JOINT**  
NOT TO SCALE

**CONCRETE BORDER**  
NOT TO SCALE



NO.	REVISION	BY	DATE
<b>icon Consulting Engineers, Inc.</b> 2840 W. Southlake Blvd., Suite 110 Civil Engineers - Designers - Planners Southlake, TX 76092 (817) 552-6210 Engineering Firm Registration Number F-9007			
<b>PAVING, DRAINAGE &amp; UTILITY IMPROVEMENTS</b> VITRUVIAN PARK PUBLIC INFRASTRUCTURE BLOCK 200 TOWN OF ADDISON, TEXAS <b>STREETSCAPE DETAILS</b>			
DESIGN	DRAWN	DATE	SCALE
ICE	ICE	APR 17, 2019	AS NOTED
NOTES			Sheet No.
			<b>78</b>

VITRUVIAN PARK BLOCK 200 PUBLIC INFRASTRUCTURE - PROJECT NO. 5029-04