

GENERAL NOTES:

- BOUNDARY INFORMATION TAKEN FROM ARCHITECTURAL PLANS PREPARED BY BY HALFF ASSOCIATES 8616 NORTHWEST PLAZA DRIVE, DALLAS, TEXAS 75225 CONTRACTOR SHALL FIELD VERIFY ALL CONTROL DIMENSIONS, ELEVATIONS AND FLOW LINE ELEVATIONS PRIOR TO CONSTRUCTION AND REPORT DISCREPANCIES TO THE ARCHITECT. TOPOGRAPHIC INFORMATION PROVIDED BY GLOBAL LAND SURVEYING, INC. 704 CENTRAL PARKWAY EAST PLANO, TEXAS.
- ELEVATIONS/SPOT GRADES SHOWN ARE FINISH GRADES/CONTOURS. COORDINATE GRADING AND/OR ELEVATIONS WITH ARCHITECTURAL AND LANDSCAPE DRAWINGS. REFER TO SITE PLAN FOR ALL DIMENSIONS NOT SHOWN.
- LOCATION, SIZE AND TYPE OF EXISTING UTILITIES WERE BASED UPON NOTED PLANS. CONTRACTOR SHALL BE RESPONSIBLE FOR LOCATING ALL UTILITIES TO CONNECT WITH, OR THAT MAY CONFLICT WITH, HIS/HER CONSTRUCTION CONTRACTOR IS RESPONSIBLE FOR PROTECTION OF ALL UTILITIES DURING CONSTRUCTION.
- ALL UTILITY CONSTRUCTION SHALL BE IN ACCORDANCE WITH THE STANDARD SPECIFICATIONS AND DETAILS OF THE NORTH CENTRAL TEXAS COUNCIL OF GOVERNMENTS WITH THE CITY OF ADDISON, TEXAS AMENDMENTS UNLESS NOTED OTHERWISE.
- TYPICAL PAVING AT FIRE LANE SHALL BE 8" THICK, NORMAL WEIGHT CONCRETE WITH A MINIMUM 28 DAY ULTIMATE COMPRESSIVE STRENGTH OF 3500 PSI REINFORCED WITH #3 @ 18" ON CENTER EACH WAY, 2" CLEAR FROM TOP OF SLAB. SEE NOTE 6 FOR SUBGRADE AND JOINTING REQUIREMENTS.
- OTHER PAVING SHALL BE 6" THICK, NORMAL WEIGHT CONCRETE WITH A MINIMUM 28 DAY ULTIMATE COMPRESSIVE STRENGTH OF 3500 PSI REINFORCED WITH #3 @ 18" ON CENTER EACH WAY, 2" CLEAR FROM TOP OF SLAB. SUBGRADE SHALL BE COMPACTED TO A MINIMUM OF 95% STANDARD PROCTOR MINIMUM, AT A MOISTURE CONTENT OF MINUS 1% TO PLUS 4% OF OPTIMUM PER ASTM D-698. CONTRACTOR SHALL PROVIDE CONSTRUCTION OR CONTRACTION JOINTS AT 15' ON CENTER EACH WAY MAXIMUM, WITH EXPANSION JOINTS AT EVERY FOURTH JOINT (60' ON CENTER MAX.) EACH DIRECTION. CONTRACTOR SHALL SUBMIT JOINTING PLAN FOR REVIEW AND APPROVAL.
- ALL OTHER SITE CONCRETE SHALL BE NORMAL WEIGHT, 28 DAY MIN. ULTIMATE COMPRESSIVE STRENGTH OF 3000 PSI. ALL REINFORCING SHALL CONFORM TO ASTM A-615, GRADE 60. WELDED WIRE FABRIC SHALL CONFORM TO ASTM A-185. ALL SIDEWALKS SHALL BE 4" THICK, REINFORCED WITH 6X6-W1.4XW1.4 WMF OVER 2" SAND CUSHION. SEE ARCHITECTURAL FOR SPECIFICATIONS AND FINISHES.
- ALL SITE FILL MATERIAL MAY BE ON-SITE, OR SIMILAR, MATERIAL (REFER TO SOILS REPORT FOR TYPE) UNDER PAVING. AT CUT SECTIONS, OR EXISTING GROUND PRIOR TO FILLS, SCARIFY 6" AND RECOMPACT TO A MINIMUM OF 95% OF MAX DRY DENSITY FROM ASTM D-698 AT MOISTURE CONTENT BETWEEN -1% AND +4% ABOVE OPTIMUM. FILLS SHALL BE PLACED IN LESS THAN EIGHT LOOSE INCH LIFTS AND COMPACTED AS NOTED ABOVE. REFER TO SPECIFICATIONS FOR FILL AND COMPACTION UNDER BUILDING.
- CONTRACTOR IS RESPONSIBLE FOR SAFETY ON THE PROJECT AND SHALL PROVIDE CONSTRUCTION PER OSHA REQUIREMENTS, TITLE 29, (LATEST), AS WELL AS OTHER APPLICABLE BUILDING CODE REQUIREMENTS.
- CONTRACTOR SHALL PROVIDE EROSION PROTECTION PER BMP MANUAL "STORM WATER QUALITY BEST MANAGEMENT PRACTICES FOR CONSTRUCTION ACTIVITIES" AS PUBLISHED BY THE NORTH CENTRAL TEXAS COUNCIL OF GOVERNMENTS. PROVIDE HAY BALES OR SILT FENCE AT DOWNHILL SIDE OF ALL EXCAVATIONS GREATER THAN TEN FEET WIDE AND AT NO GREATER THAN 100' APART AT LARGER, OR LONGER, EXCAVATIONS.

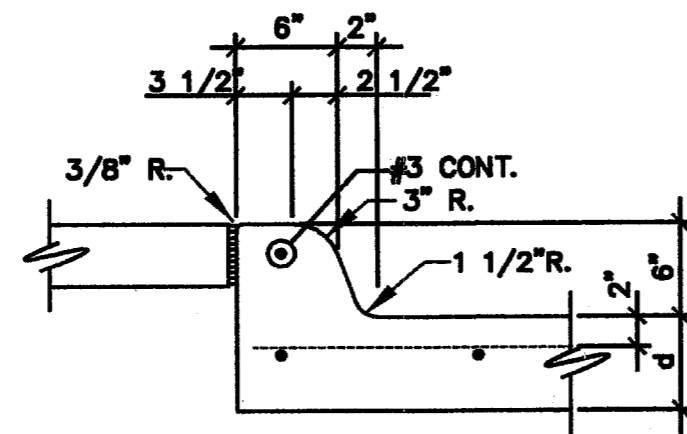

01 TYPICAL INTEGRAL CURB DET.

1"-1'-0"

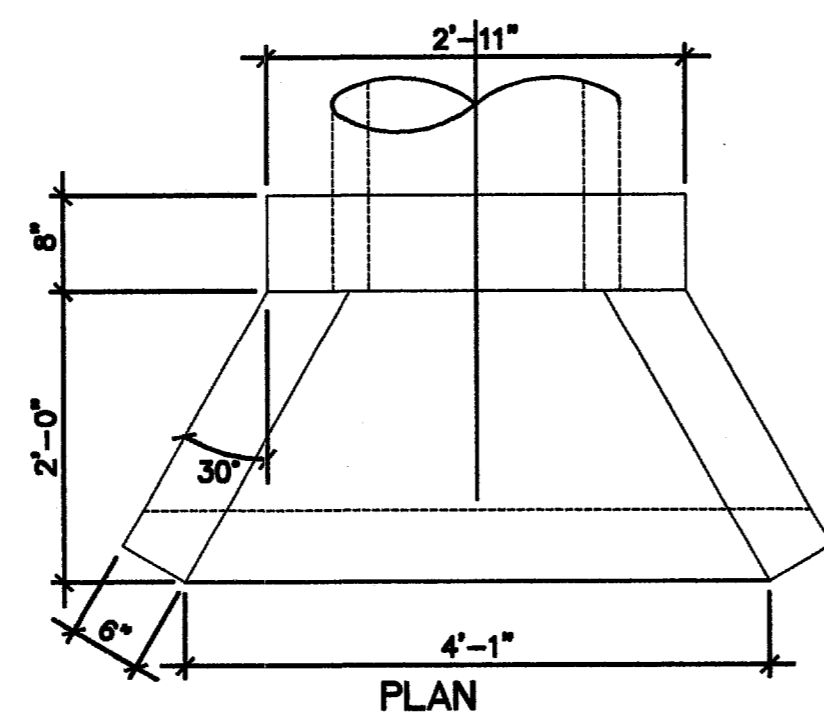
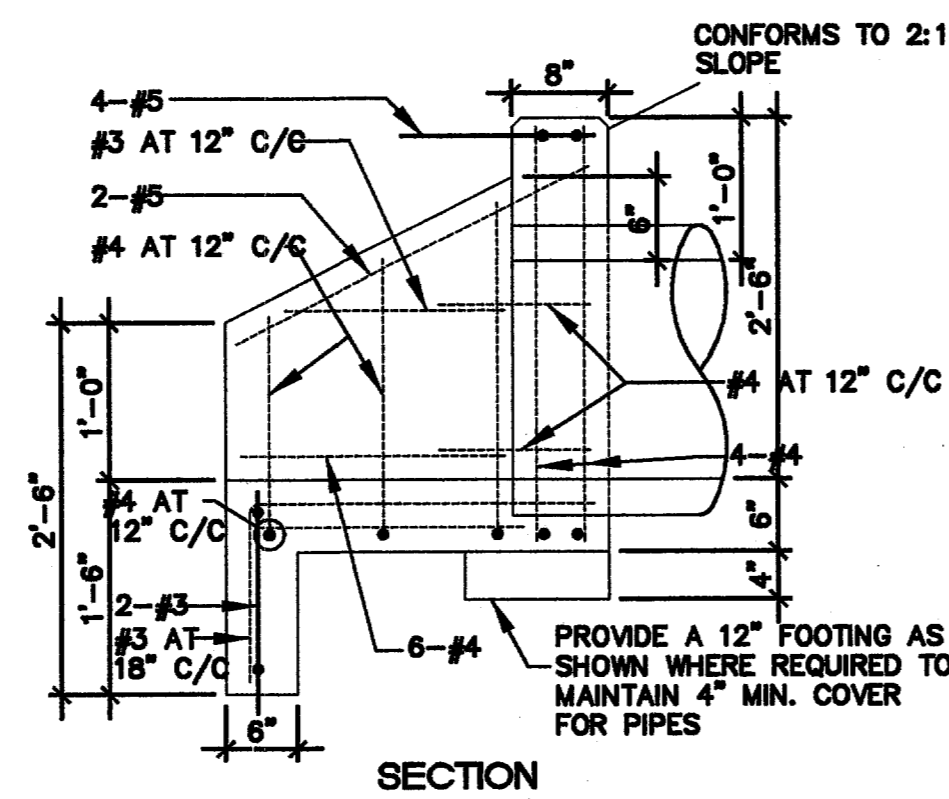
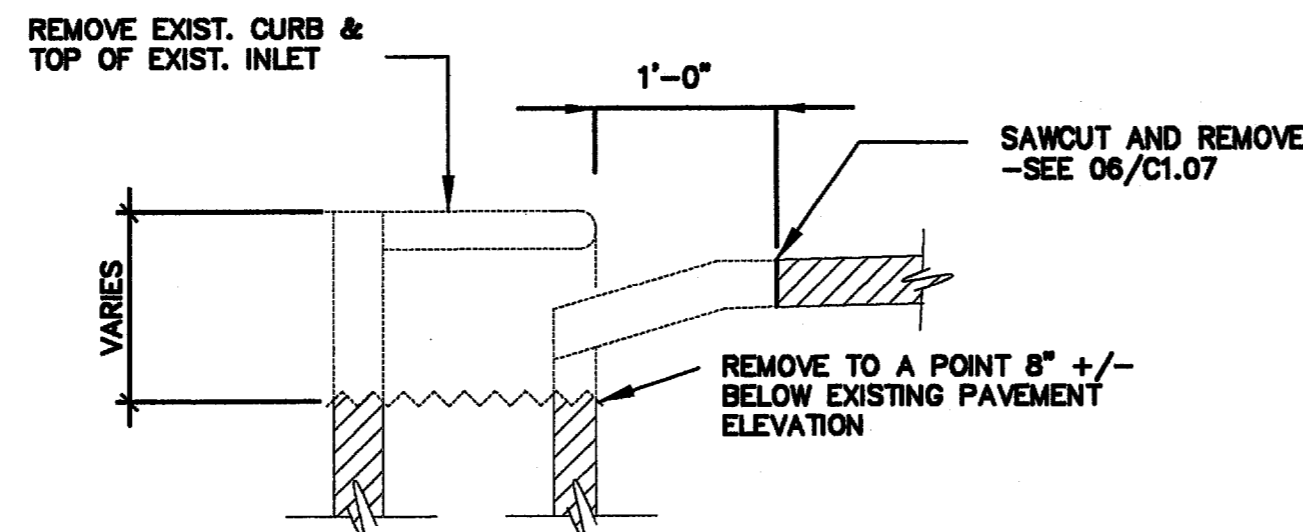
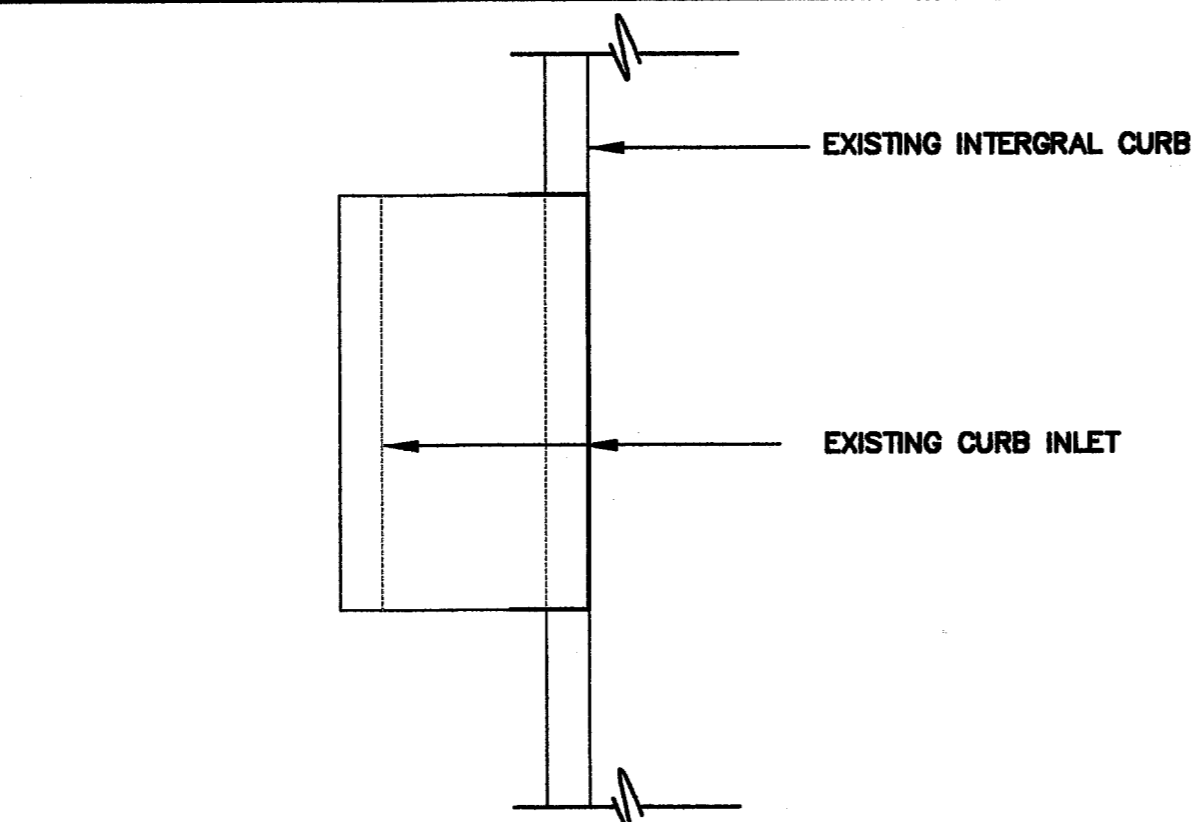

07 STANDARD HEADWALL

3/4"-1'-0"

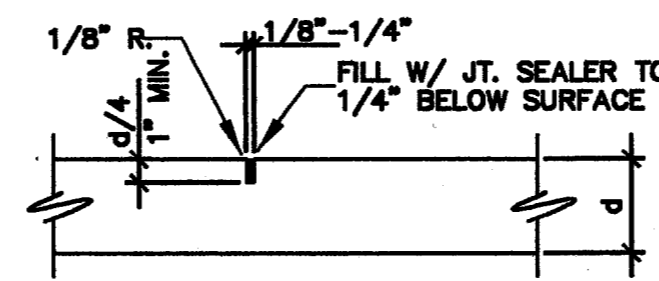

02 TYP. CONTRACTION JT.

1"-1'-0" SAWED OR DUMMY GROOVE

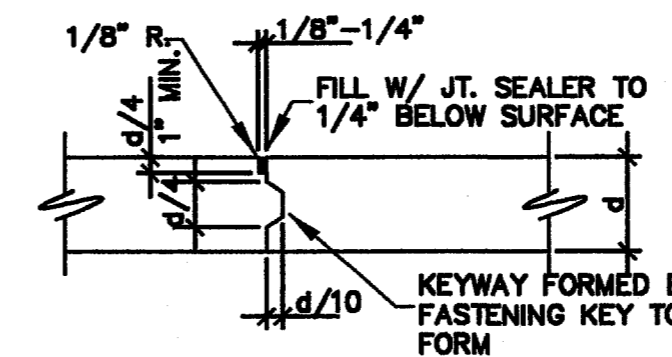

03 TYP. KEYED CONST. JT.

1"-1'-0" LOCATE CONSTRUCTION OR CONTRACTION JOINT AT

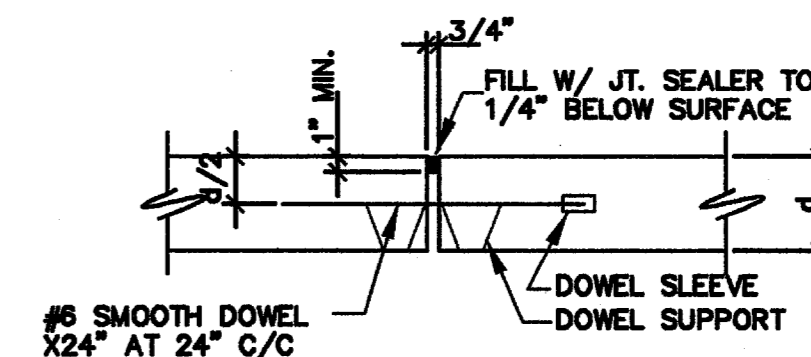

04 TYP. EXPANSION JT.

1"-1'-0" LOCATE 60'-0" C/C MAX. AND PARALLEL W/ TYPICAL PAVING AND INNER CURB RETURN

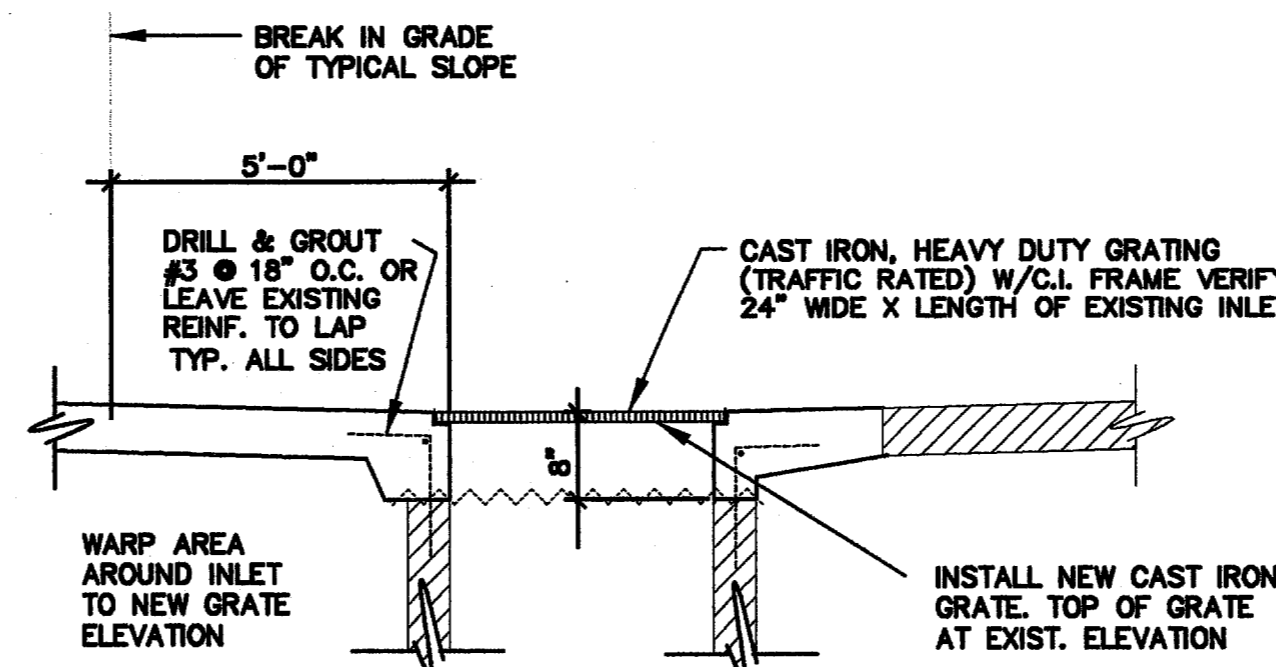

05 SECTION AT EXISTING INLETS

NOT TO SCALE

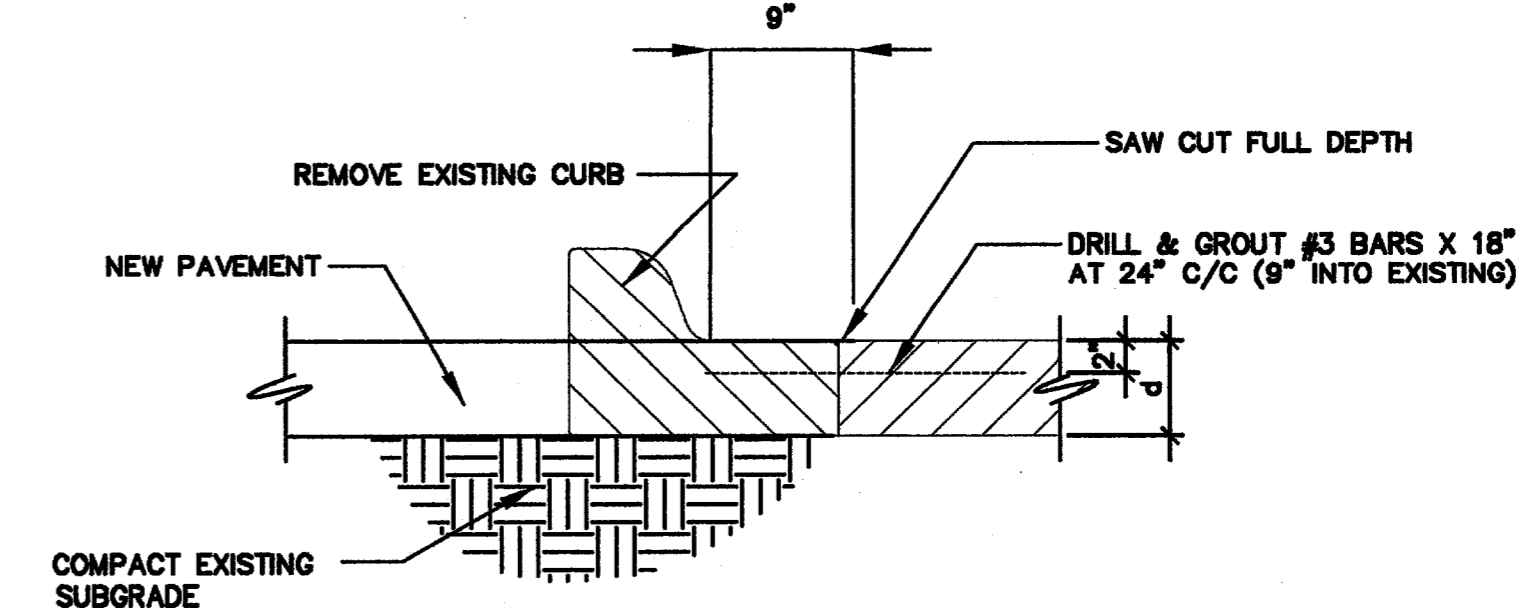

06 CONNECTION AT EXISTING PAVEMENT

1"-1'-0"

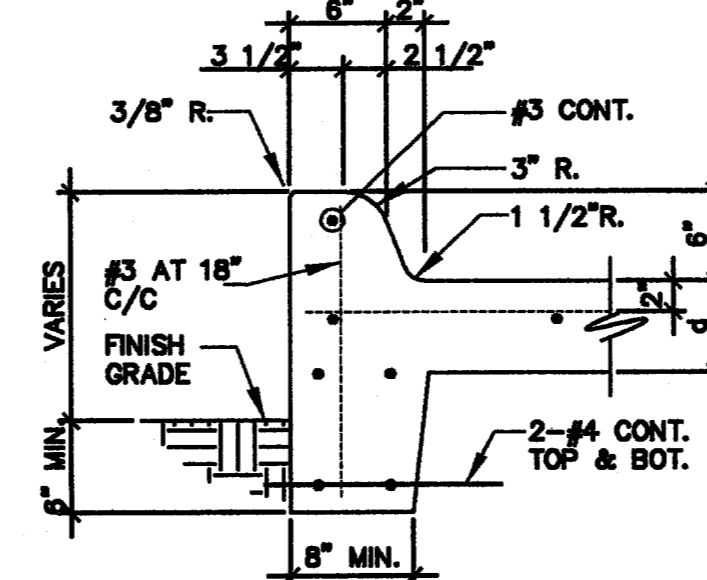

08 TYPICAL TURNED-DOWN CURB

1"-1'-0"

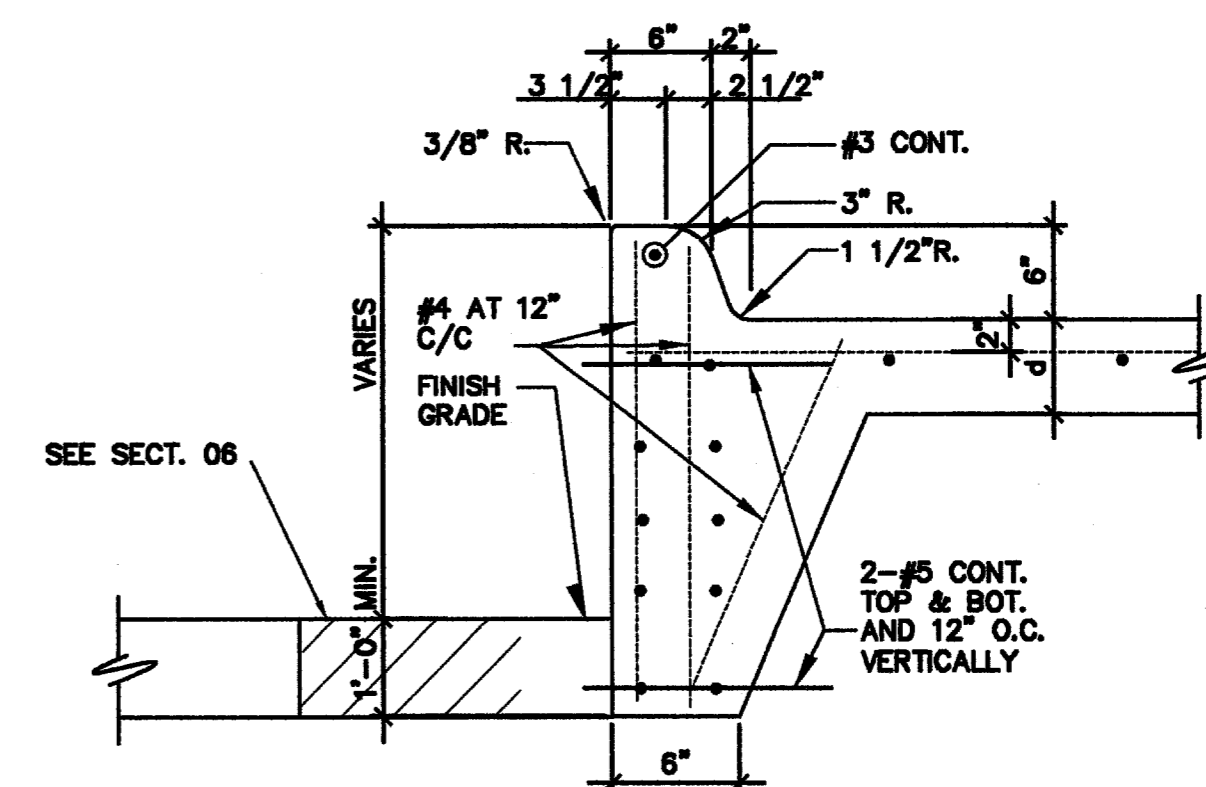

09 CURB AT RELOCATED FIRE LANE

1"-1'-0"

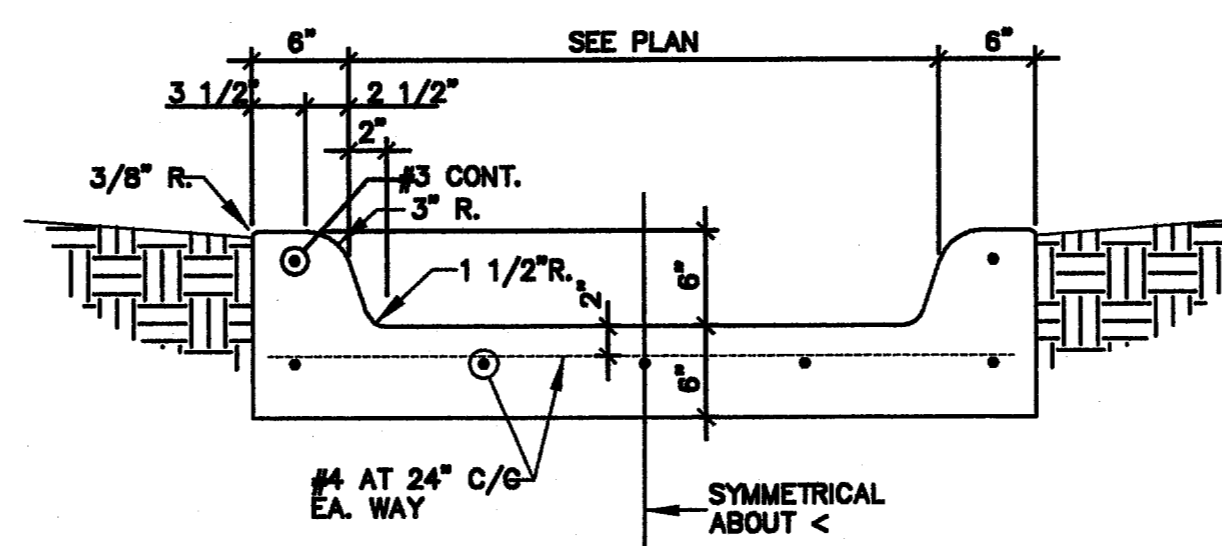

10 TYPICAL CURB FLUME

1"-1'-0"

PROJECT:
UNITED STATES ENVIRONMENTAL PROTECTION AGENCY

16850 WESTGROVE DRIVE SUITES 200 & 300 ADDISON, TEXAS 75001

CITY PROJECT NUMBER PWW# 2008-20

ARCHITECT



3311 Elm Street, Suite 105
 Dallas, Texas 75226
 214-742-6044
 214-742-6041 Fax

ARCHITECT'S SEAL:

CONSULTANT:



TMBP

CONSULTING ENGINEERS INC.
 2301 N. AKARD ST. SUITE 405
 DALLAS, TEXAS 75201
 (214) 671-3332 (214) 671-0719 FAX
 THE SEAL APPEARING ON THIS DOCUMENT WAS AUTHORIZED BY JOSEPH T. PITT, P.E. 33844 ON JANUARY 6, 2009

ISSUE HISTORY:

| CITY REVIEW | DATE |
|-------------|----------|
| | 01/07/09 |
| | |
| | |
| | |
| | |
| | |
| | |
| | |

DRAWING INFO:

FILE:
 CURRENT ISSUE:
 DRAWN BY:
 CHECKED BY: JTP

SHEET NUMBER:

GENERAL NOTES AND DETAILS

C1.07