

TYPICAL THICKNESS TRANSITION SECTION
N.T.S.

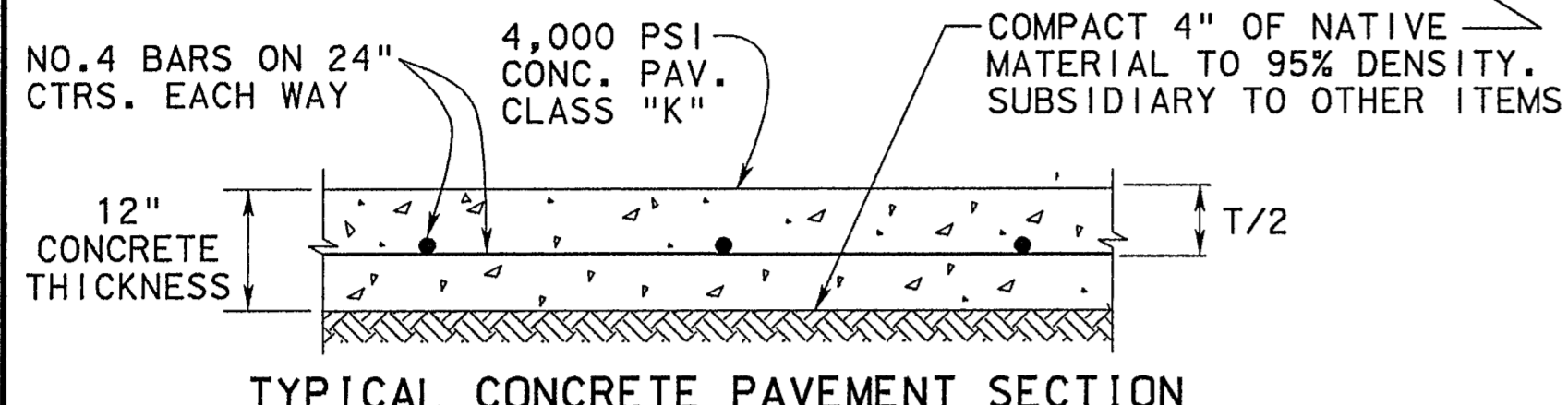

TYPICAL CONCRETE PAVEMENT SECTION
N.T.S.

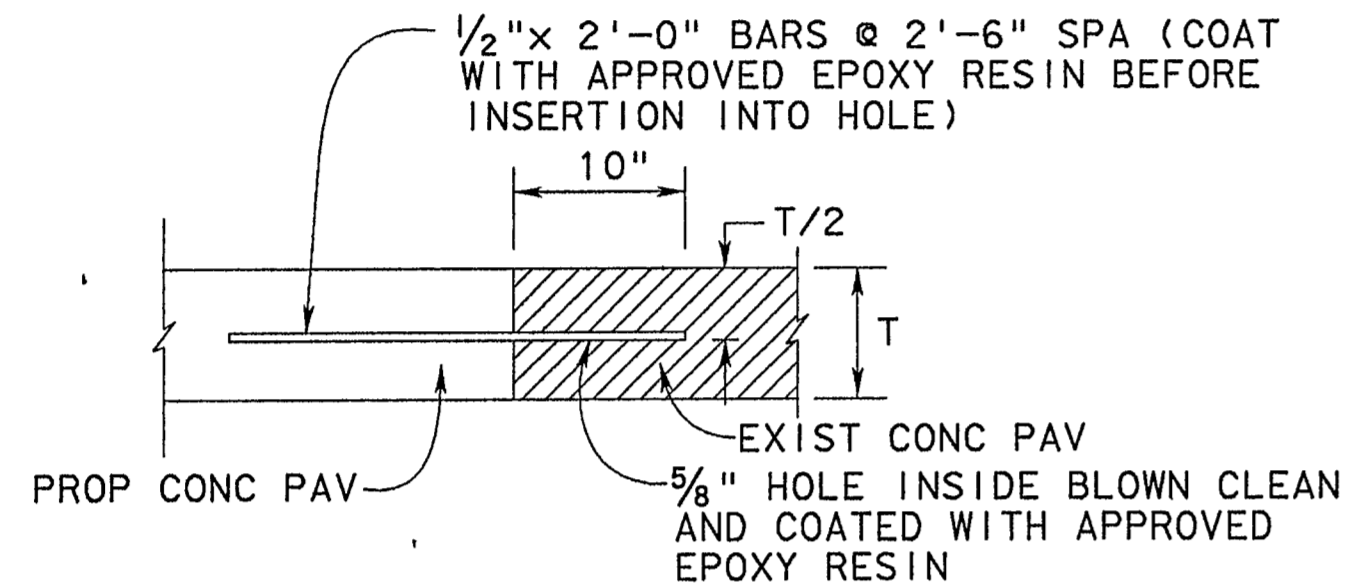

ANCHOR JOINT DETAIL
N.T.S.

TO BE USED WHERE PROPOSED CONCRETE PAVEMENT MEETS EXISTING CONCRETE PAVEMENT, SUBSIDIARY TO OTHER ITEMS

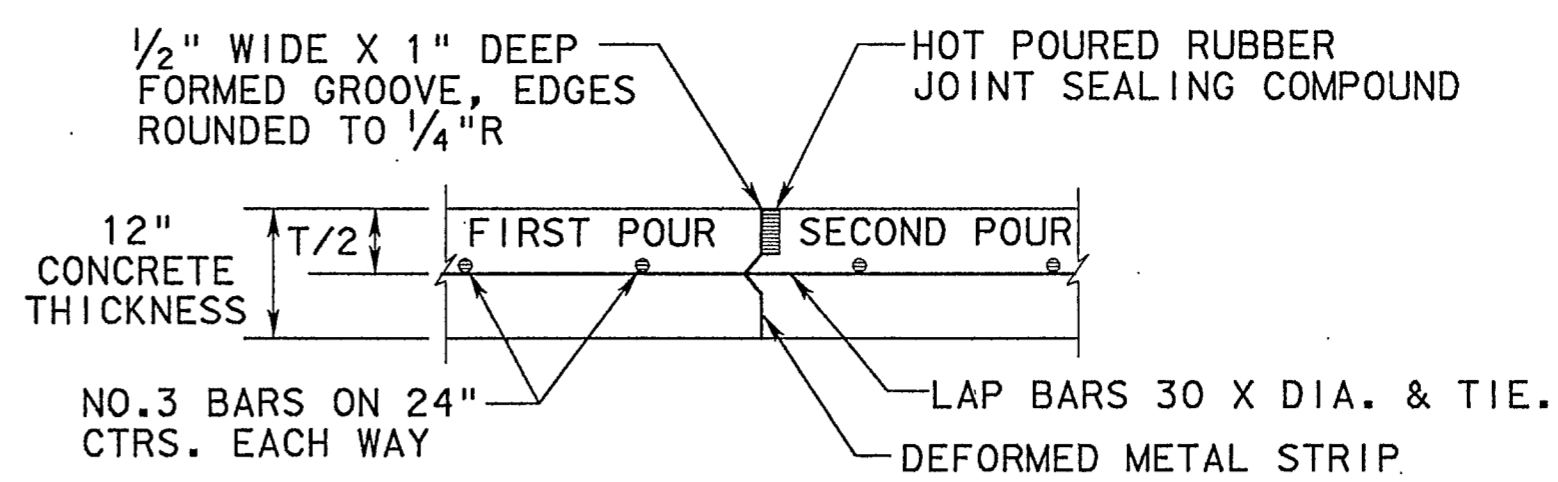

CONSTRUCTION JOINT DETAIL
N.T.S.

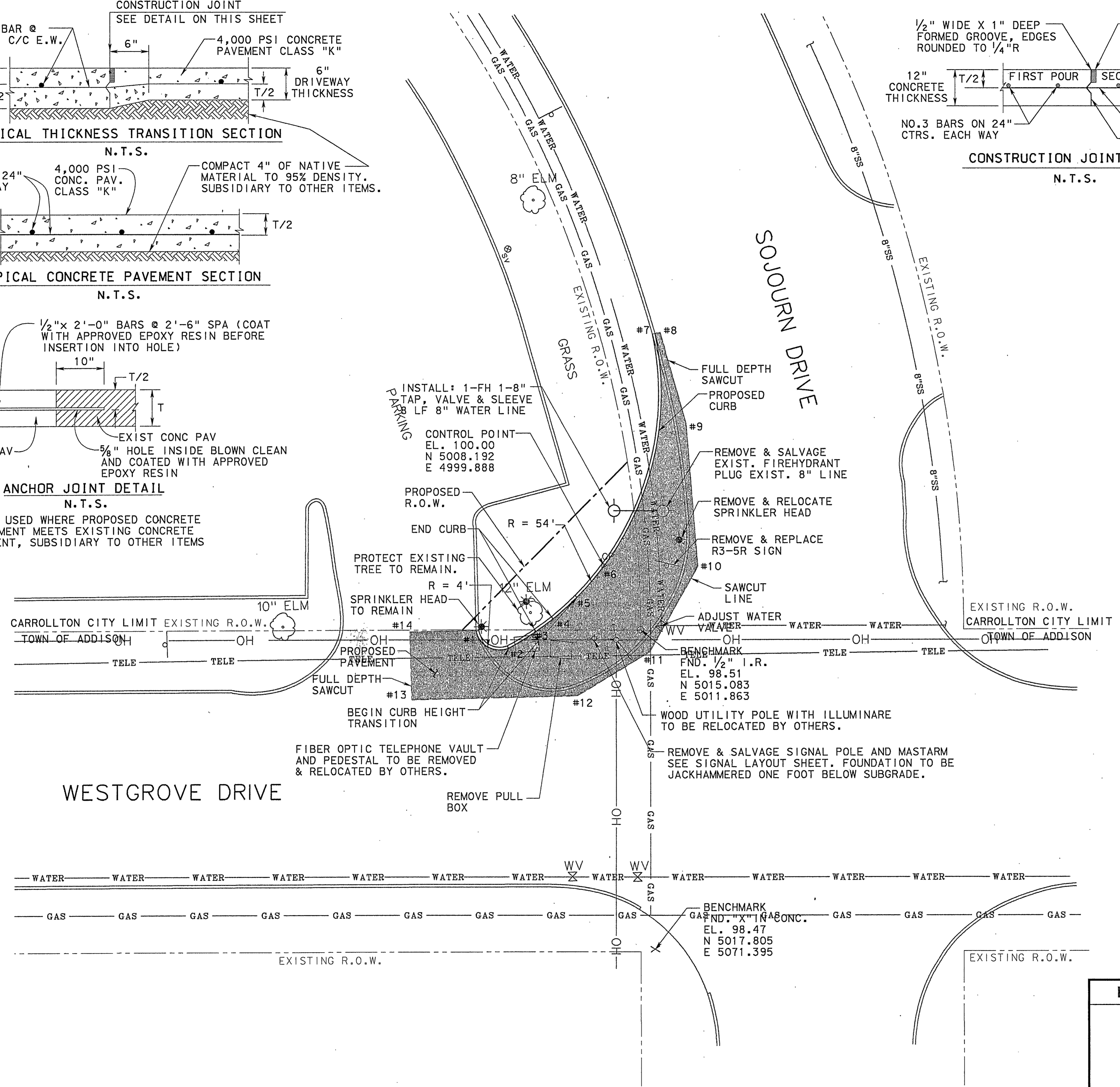
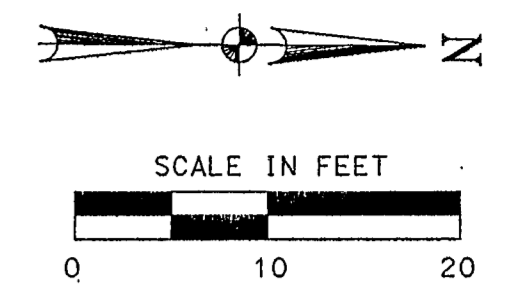



POINT CHART			
No.	NORTHING	EASTING	ELEVATION
*1	4984.390	5011.910	98.92
2	4990.464	5015.326	98.83
3	4995.580	5012.199	98.73
4	4998.780	5009.811	98.63
5	5003.231	5005.801	98.53
*7	5017.772	4956.331	98.06
*8	5018.737	4956.058	98.16
*9	5023.583	4973.215	98.32
*10	5025.725	5000.108	98.58
*11	5016.747	5016.066	98.39
*12	5003.258	5024.193	98.45
*13	4972.387	5024.942	98.54
*14	4972.040	5012.247	98.92

* CONTRACTOR TO FIELD VERIFY EXIST. GRADE ELEVATION.

NOTE:

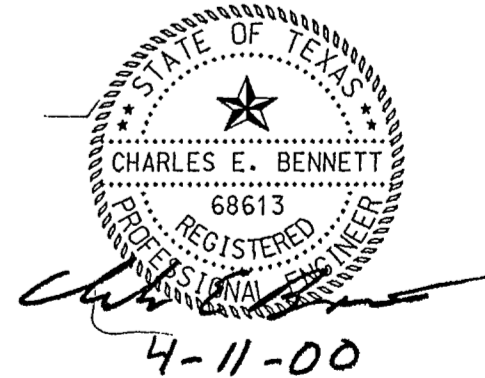
- 1. DIMENSIONS AND COORDINATES SHOWN ARE FROM FACE OF CURB UNLESS OTHERWISE NOTED.
- 2. ALL ELEVATIONS ARE FROM THE TOP OF PAVEMENT.
- 3. CONTROL POINT NUMBERS ARE INDICATED BY SYMBOL #6 REFER TO COORDINATE POINT CHART TABLE ON THIS SHEET.
- 4. CONTRACTOR TO FIELD VERIFY ALL DIMENSIONS AND CONTROL POINTS PRIOR TO PLACING CONCRETE.
- 5. CONTRACTOR TO ADJUST WATER VALVES, WATER METERS, SPRINKLER HEADS AND PULL BOXES TO GRADE SUBSIDIARY TO OTHER ITEMS.
- 6. CONTRACTOR TO REMOVE, SALVAGE AND DELIVER FIRE HYDRANT TO CITY OF CARROLLTON DISTRIBUTION CENTER.
- 7. CONTRACTOR TO PROVIDE BELTING OR BURLAP DRAG FINISH TO PAVEMENT SURFACE.
- 8. CONTRACTOR TO MATCH EXISTING SAW CONTRACTION JOINTS AND INTERSECT PROPOSED CURB AT RIGHT ANGLE, SEE TRAFFIC CONTROL SHEET.
- 9. CONTRACTOR TO REFER TO CITY OF CARROLLTON UTILITY RELOCATION STANDARD DETAILS.



	DART PROJECT		INTERSECTION IMPROVEMENTS SOJOURN DR. AT WESTGROVE DR.			
	TOWN OF ADDISON					
	PAVING LAYOUT SHEET					
DESIGNED	DRAWN	CHECKED	DATE	SCALE	SHEET NO.	
CAJ	CAJ	CEB	4/11/00	1" = 20'	4 OF 6	

Filename: t:\TRANS\Dar-HDV\Tof6\Microstia\Sheets\soj\plan.dgn