

Note: One expansion joint shall be placed near the center of the wall's length aligning with the nearest control joint in the street. Toolled control joints shall be placed aligning with all saw-cut control joints in the street.

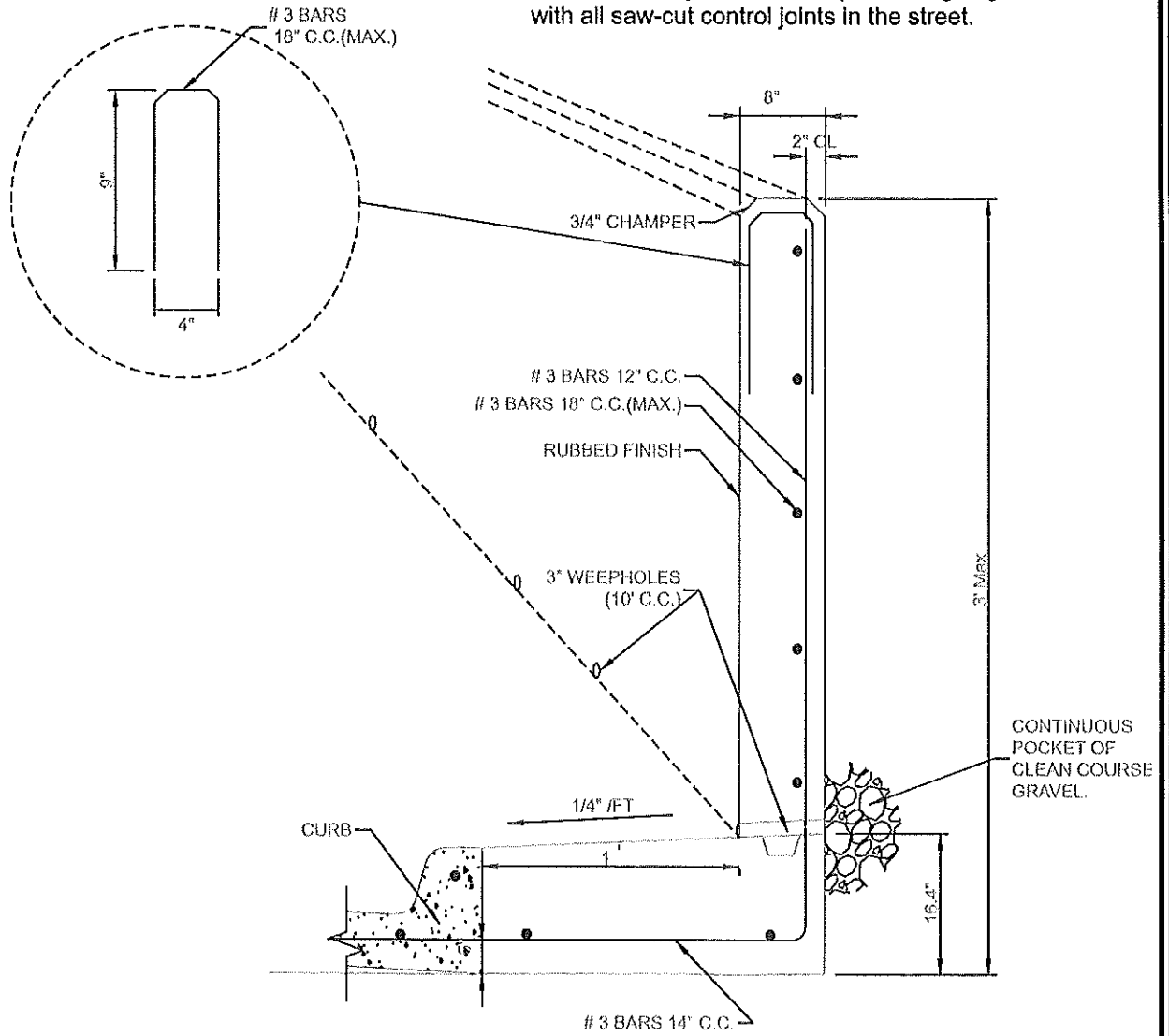

Addison!

DEPARTMENT OF ENGINEERING

RETAINING WALL

ADDISON ROAD CONSTRUCTION DETAIL
REVISED RETAINING WALL

DATE:
OCT 2007

REV DATE:
OCT 2007

SHEET:
1 OF 1

Note: One expansion joint shall be placed near the center of the wall's length aligning with the nearest control joint in the street.
 Tooled control joints shall be placed aligning with all saw-cut control joints in the street.

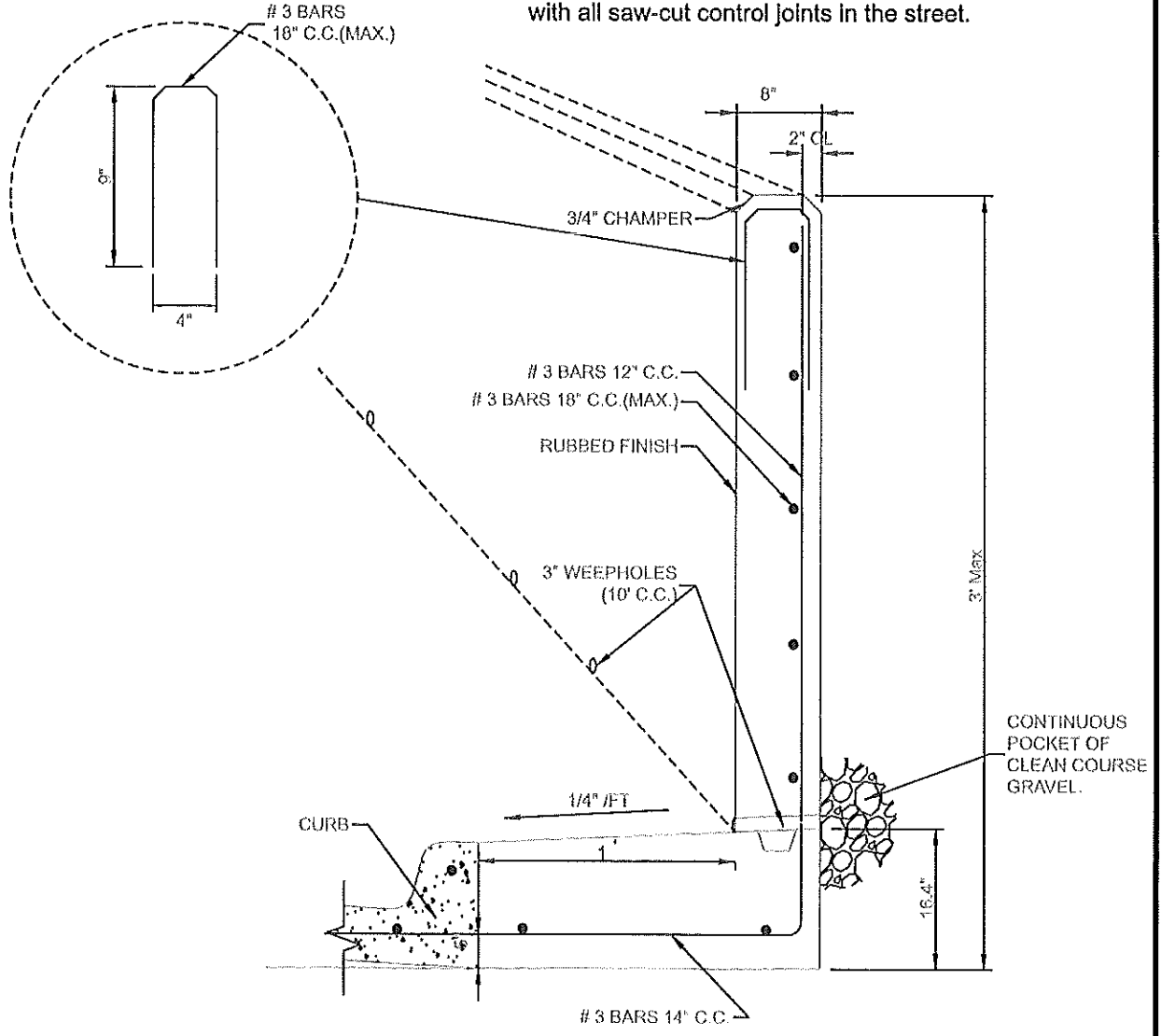

Addison!

DEPARTMENT OF ENGINEERING

RETAINING WALL

ADDISON ROAD CONSTRUCTION DETAIL
 REVISED RETAINING WALL

DATE:
 OCT 2007

REV DATE:
 OCT 2007

SHEET :
 1 OF 1