

01 SIDEWALK DETAIL
NOT TO SCALE

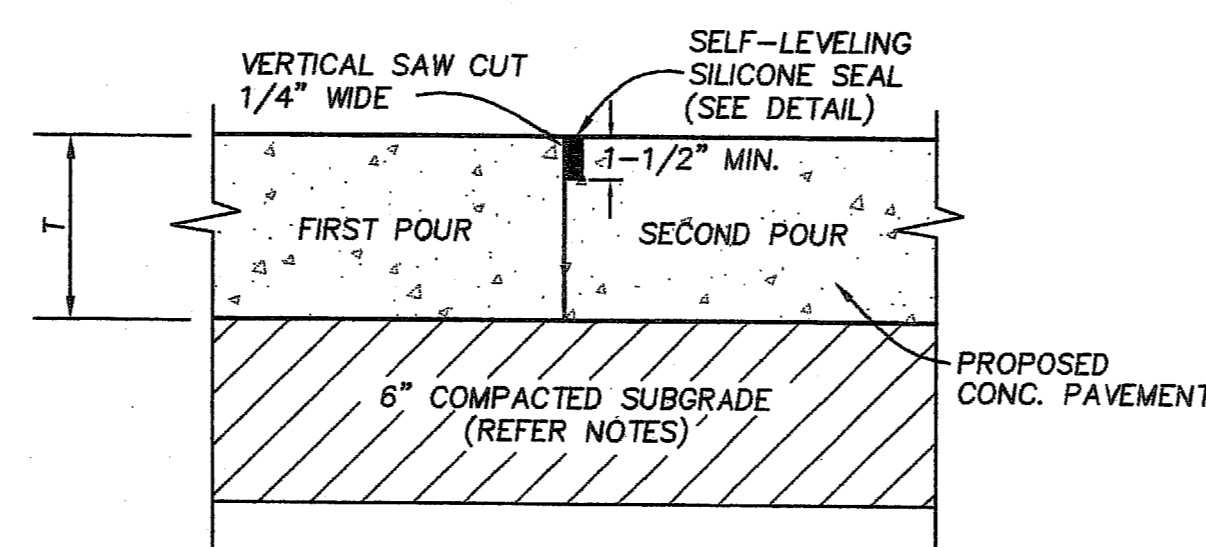

02 LONGITUDINAL OR TRANSVERSE CONSTRUCTION JOINT
NOT TO SCALE

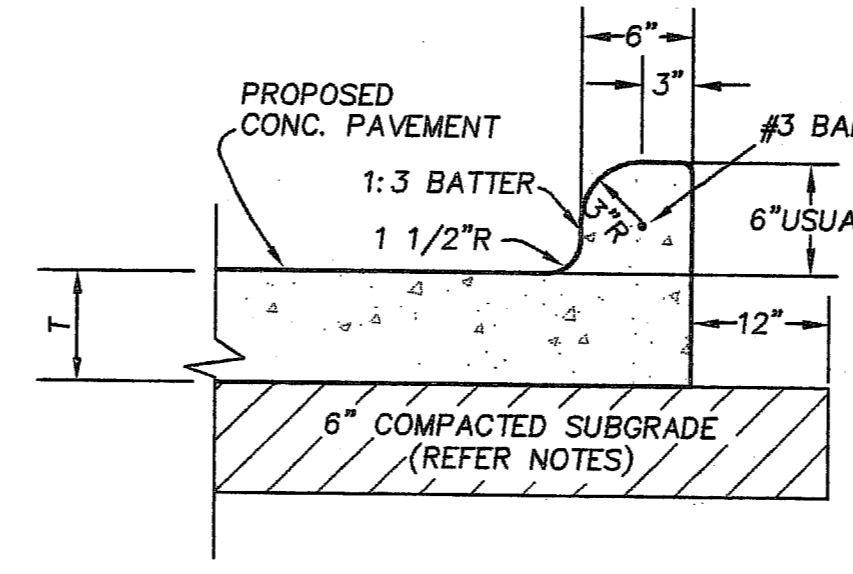

03 INTEGRAL 6" CURB SECTION
NOT TO SCALE

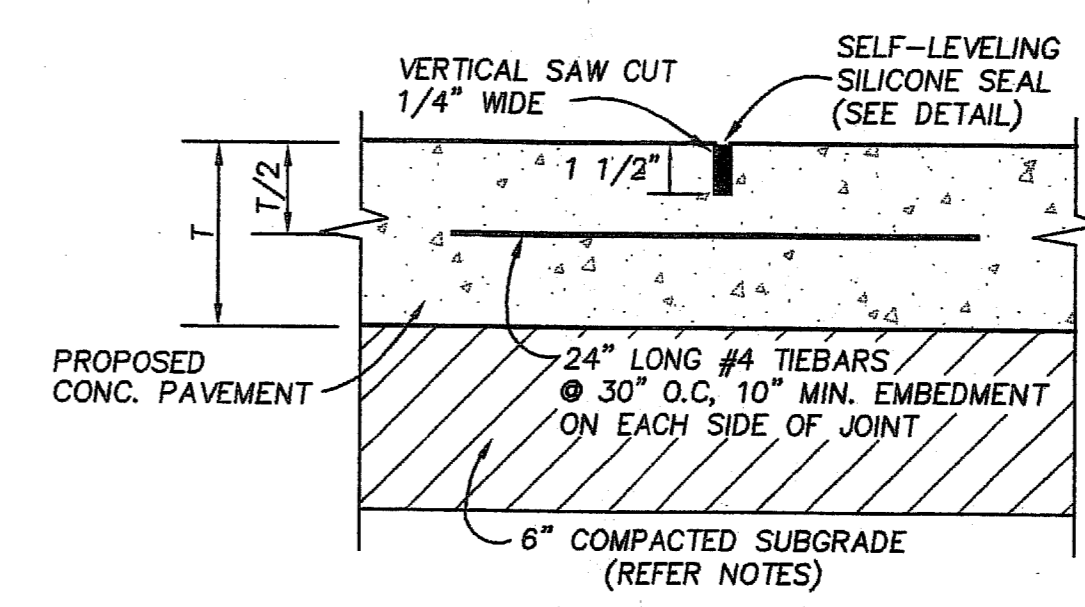

04 LONGITUDINAL OR TRANSVERSE TIED CONTRACTION JOINT
NOT TO SCALE

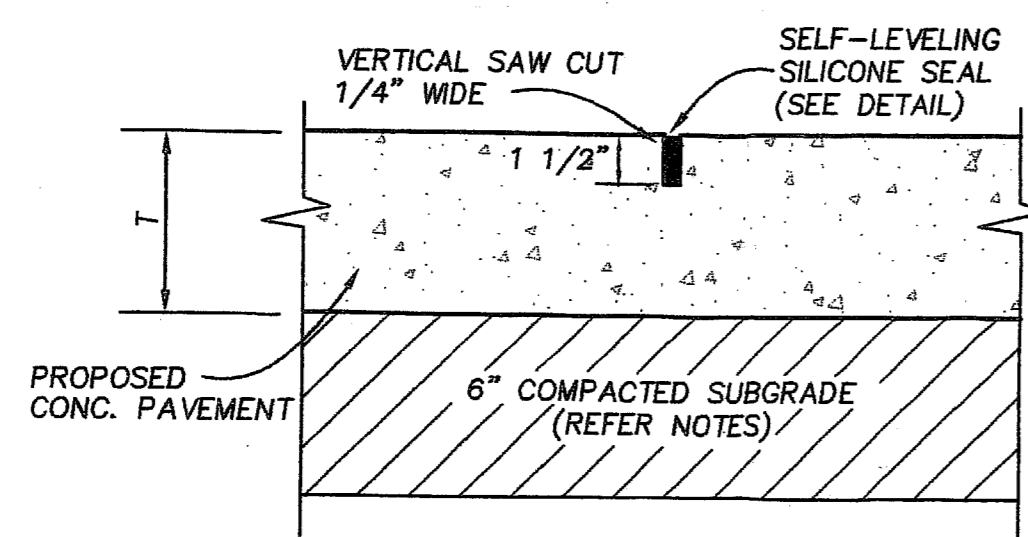

05 LONGITUDINAL OR TRANSVERSE CONTRACTION JOINT
NOT TO SCALE

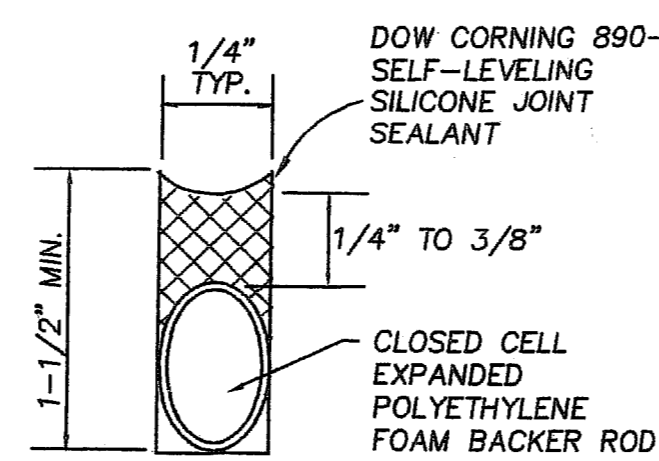

06 JOINT SEAL DETAIL
NOT TO SCALE

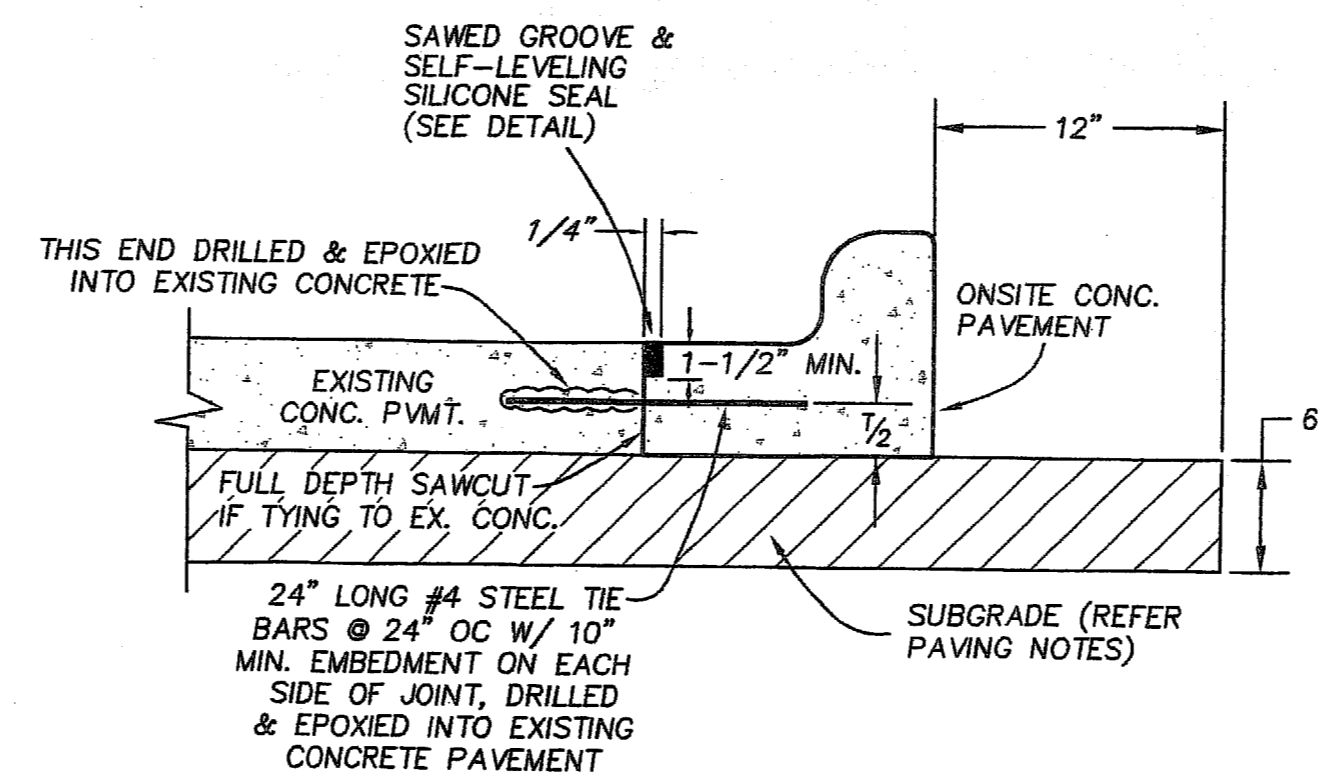

07 CONC. PVMT. CONNECTION @ CURB
NOT TO SCALE

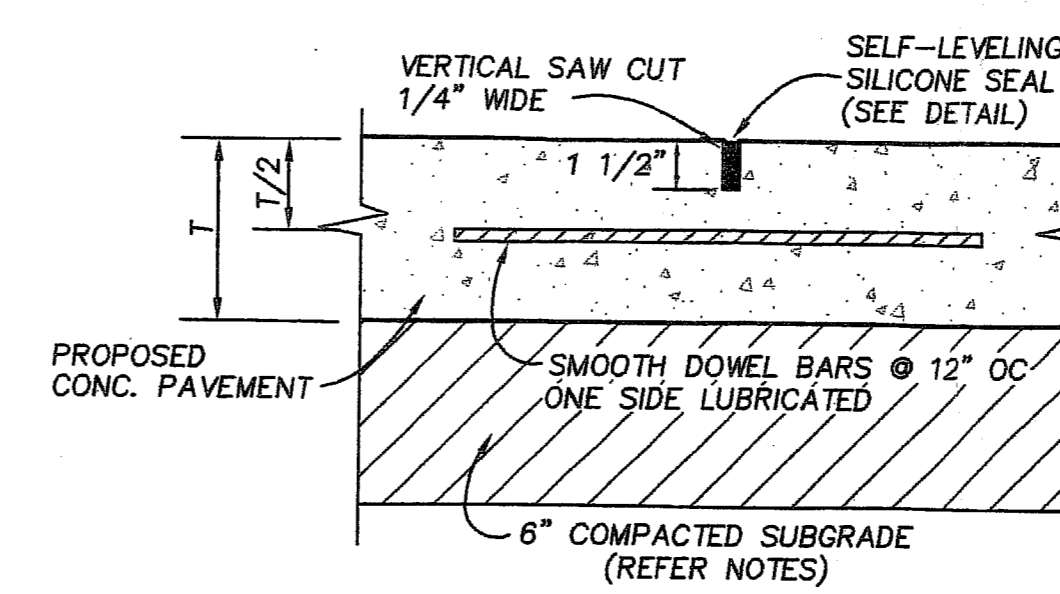

08 LONGITUDINAL OR TRANSVERSE DOWELED CONTRACTION JOINT
NOT TO SCALE

DOWEL BAR SCHEDULE

THICKNESS	BAR DIA.	BAR LENGTH	MIN. EMBEDMENT (EACH SIDE)
5"	5/8"	12"	5"
6"	3/4"	14"	6"
7"	7/8"	14"	6"
8"	1"	14"	6"

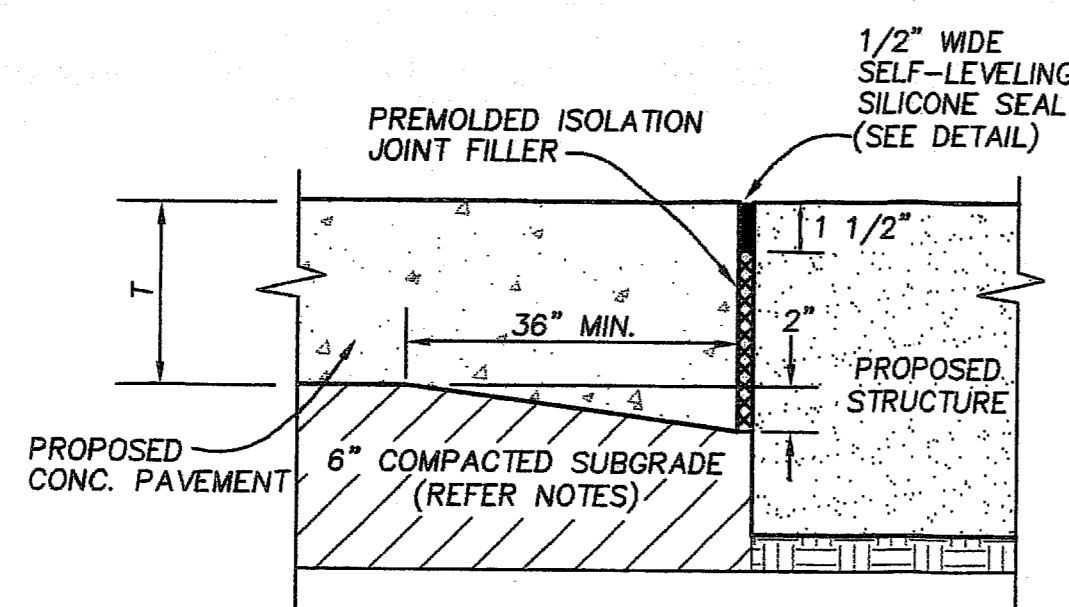

09 ISOLATION JOINT
NOT TO SCALE

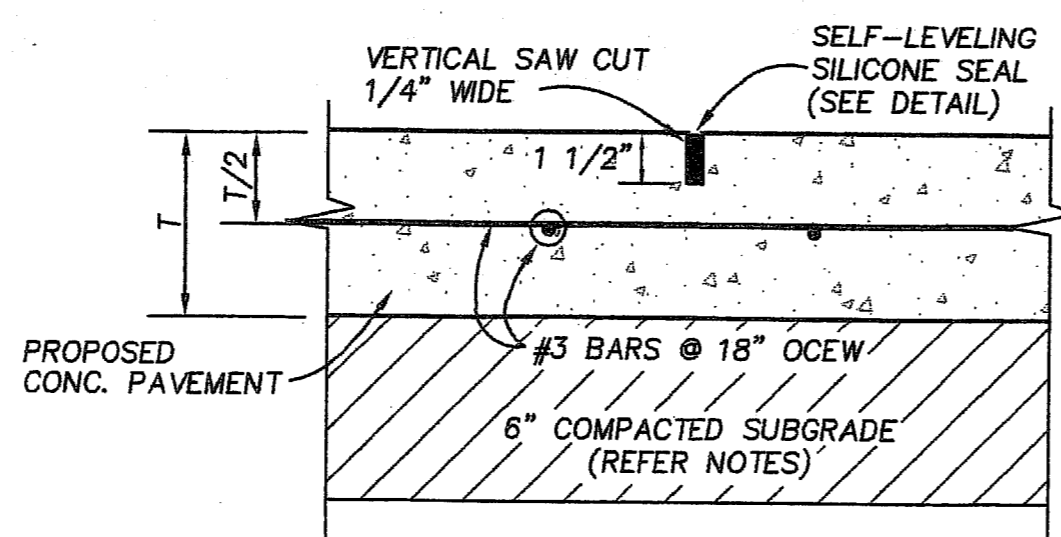

10 REINFORCEMENT DETAIL
* FOR USE ONLY WHERE INDICATED ON PLAN
NOT TO SCALE

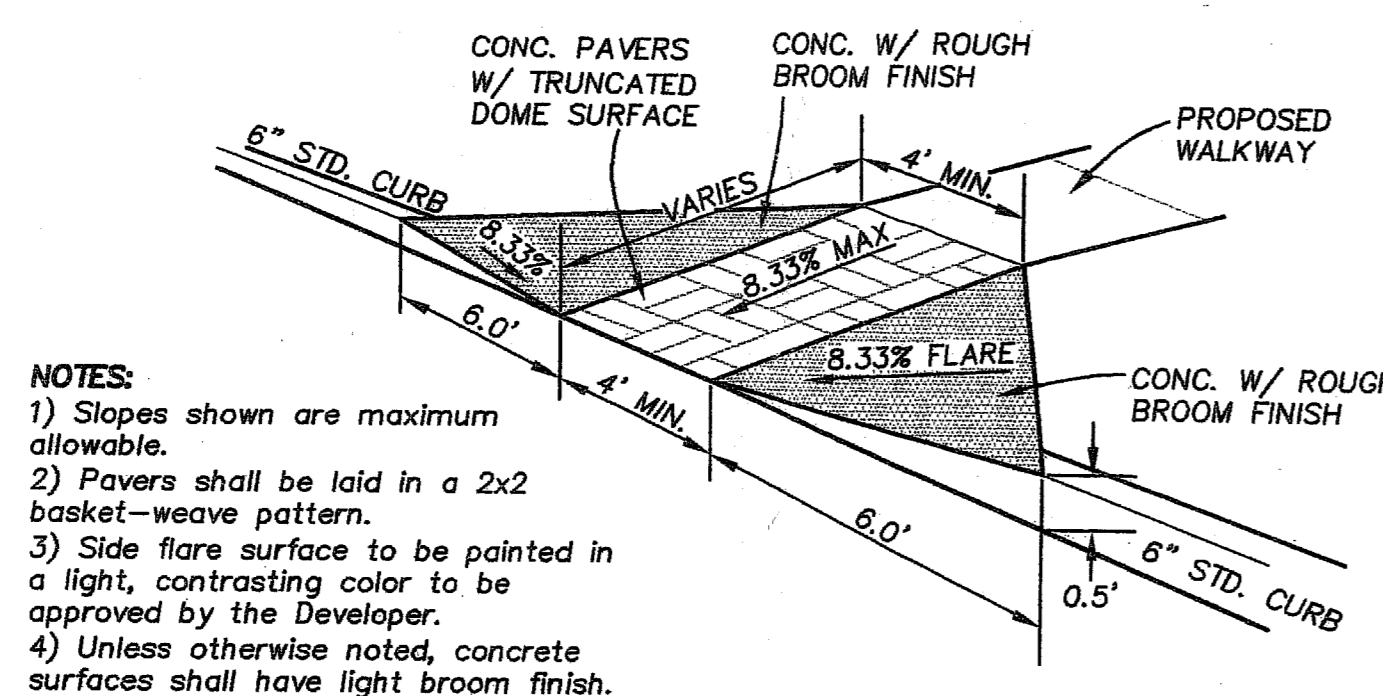

11 TYPE 1 CURB RAMP DETAIL
NOT TO SCALE

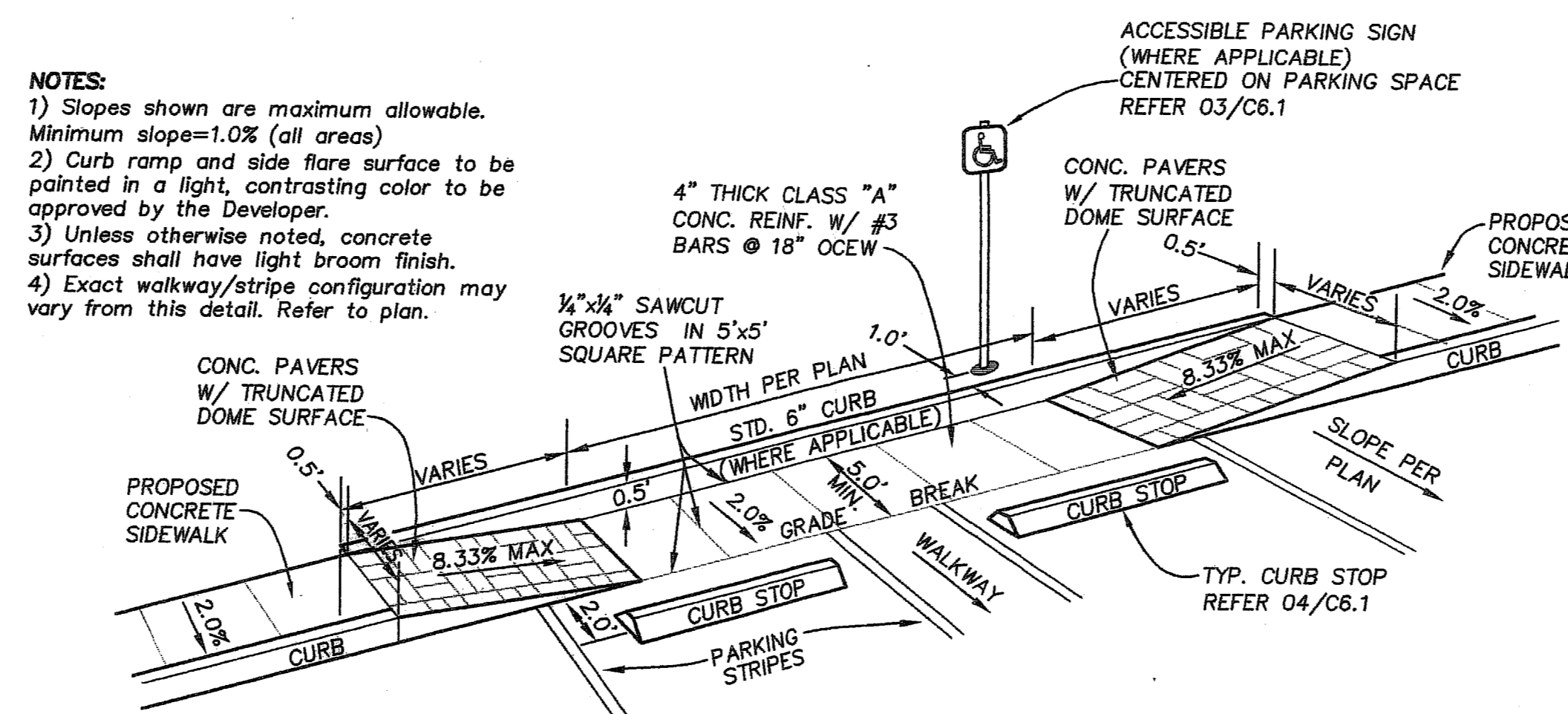

12 TYPE 2 CURB RAMP & PARKING DETAIL
NOT TO SCALE

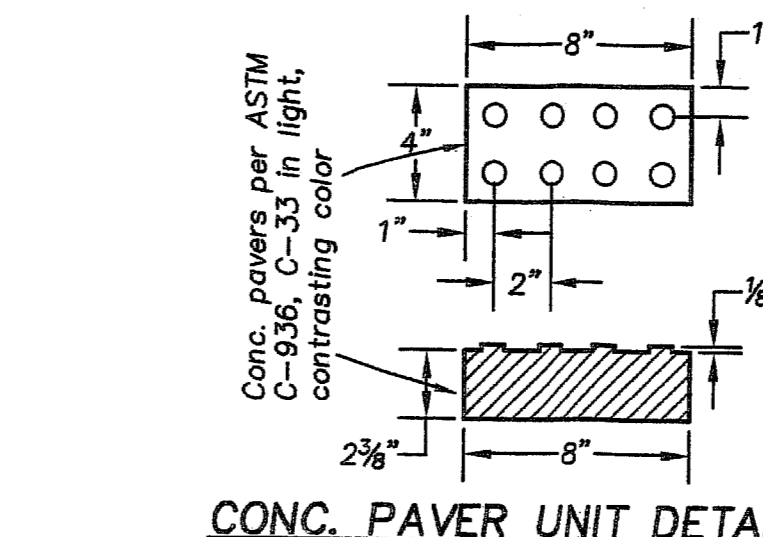

13 RAMP PAVER DETAIL
NOT TO SCALE

- NOTES:**
- 1) Slopes shown are maximum allowable. Minimum slope=1.0% (all areas)
 - 2) Curb ramp and side flare surface to be painted in a light, contrasting color to be approved by the Developer.
 - 3) Unless otherwise noted, concrete surfaces shall have light broom finish.
 - 4) Exact walkway/stripe configuration may vary from this detail. Refer to plan.

PROGRESS PLOTS
FOR INTERIM DESIGN
REVIEW ONLY
NOT FOR CONSTRUCTION
DATE: 04/28/06

DRAWING PREPARED BY:
VILBIG & ASSOCIATES, INC.
CONSULTING ENGINEERS & SURVEYORS
10132 MONROE DRIVE DALLAS, TEXAS 75229
(214) 352-7333 fax (214) 352-0999

COMPANY: BGV Building God's Way
2909 WASHINGTON BLVD. CODEN, UTAH 84001 PHONE: 801-821-4781

PROJECT: TRINITY CHRISTIAN ACADEMY NEW PERFORMING ARTS BLDG. EARLY SITE & FOUNDATION PACKAGE 17001 ADDISON RD., ADDISON, TX 75001

PROJECT MANAGER: CHRIS WILSON, P.E.

DATE: APRIL 28, 2006

PROJECT: AS-081

SCALE: C6.0

DO NOT SCALE DRAWING