

**1 SILT FENCE**  
NOT TO SCALE

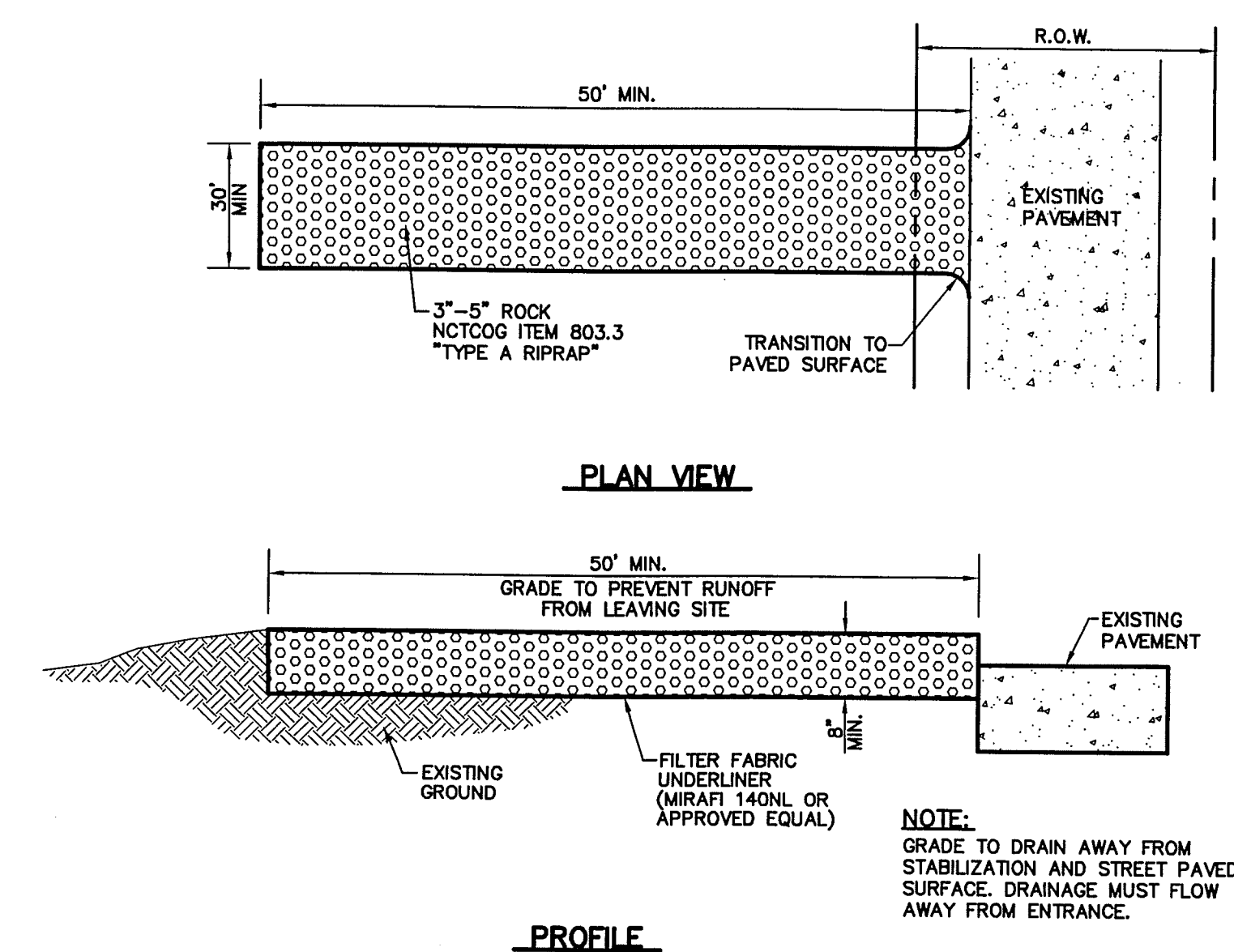

**2 STABILIZED CONSTRUCTION ENTRANCE**  
NOT TO SCALE

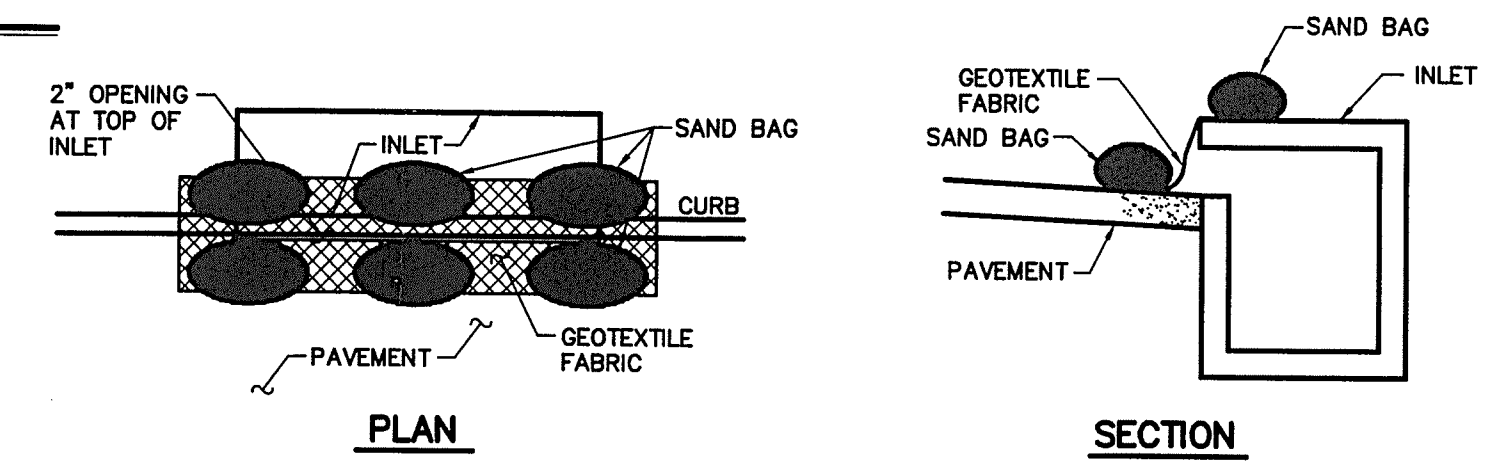

**4 CURB INLET PROTECTION "C"**  
NOT TO SCALE

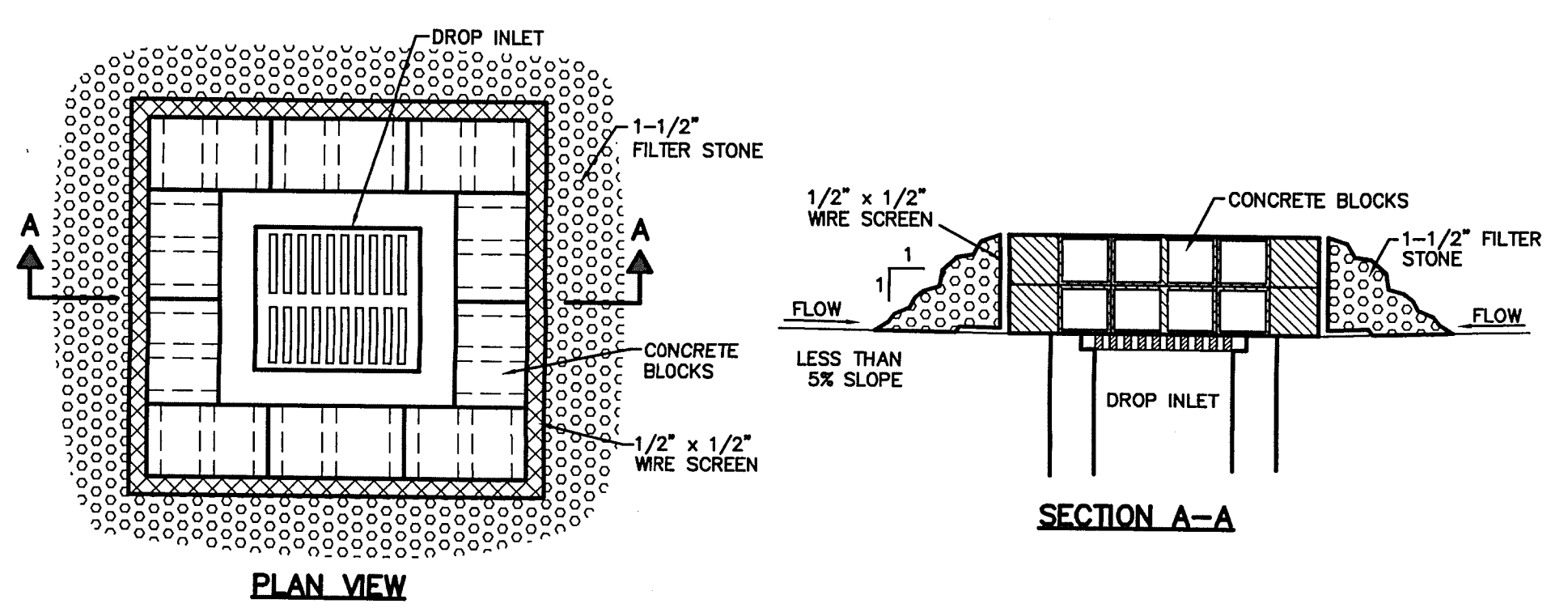

**3 DROP INLET PROTECTION**  
NOT TO SCALE

**POLLUTION CONTROL GENERAL NOTES**

1. THIS PLAN HAS BEEN PREPARED TO PROVIDE MEANS TO PREVENT OR MINIMIZE POLLUTION OF STORM WATER.
2. THE CONSTRUCTION ACTIVITY INCLUDED IN THIS PLAN WILL INCLUDE:
  - A. CLEARING AND GRUBBING
  - B. ROUGH GRADING
  - C. FINAL GRADING
  - D. UTILITY INSTALLATION
  - E. PAVEMENT INSTALLATION
  - F. BUILDING CONSTRUCTION
3. THE TOTAL ESTIMATED LAND AREA TO BE DISTURBED IS 3.2 ACRES.
4. THE ESTIMATED RUNOFF COEFFICIENT UPON COMPLETION OF THE PROJECT IS 0.9X.
5. THE STORM WATER EXITING THE SITE IS COLLECTED IN AN EXISTING DRAINAGE SYSTEM MAINTAINED BY THE TOWN OF ADDISON, TEXAS.
6. THE SOILS ON THE SITE ARE GENERALLY EXPANSIVE CLAYS.
7. THE CONTRACTOR SHALL PROVIDE AND MAINTAIN EROSION PROTECTION AROUND THE WORK AREA PERIMETER AND AT ALL INLET MOUTHS PRIOR TO COMMENCING WORK AND UNTIL THE WORK AREA HAS BEEN STABILIZED.
8. THE CONTRACTOR WILL REMOVE ALL EXCESS SOIL FROM CONSTRUCTION VEHICLES PRIOR TO EXITING THE SITE.
9. ALL DISTURBED AREAS WHICH WILL NOT BE RE-DISTURBED FOR A MINIMUM OF 21 DAYS MUST BE STABILIZED BY THE CONTRACTOR TO CONTROL EROSION.
10. THE CONTRACTOR SHALL UNDERTAKE PROPER METHODS TO REDUCE DUST GENERATION FROM THE SITE.
11. THE CONTRACTOR MUST COMPLY WITH FEDERAL, STATE AND LOCAL REGULATIONS REGARDING SEDIMENT AND EROSION CONTROL.
12. A COPY OF THIS PLAN MUST BE KEPT AT THE CONSTRUCTION FACILITY DURING THE ENTIRE CONSTRUCTION PERIOD.
13. CONSTRUCTION SEQUENCING MUST PROVIDE FOR THE EXCAVATION OF AN ON-SITE BASIN AS A SEDIMENT COLLECTION BASIN PRIOR TO THE DISTURBANCE OF GREATER THAN 10 ACRES OF LAND.
14. ALL FINISHED GRADES ARE TO BE HYDROMULCHED, SPOT SODDED OR SEEDED AND WATERED UNTIL GROWTH IS ESTABLISHED ON AND OFF-SITE.
15. A PIT OR WASH OUT BASIN SHALL BE CONSTRUCTED ON-SITE BY THE CONTRACTOR FOR THE "WASH OUT" OF CONCRETE TRUCKS.
16. A BERM OR OTHER SPILL PROTECTION MEASURE SHALL BE USED FOR ANY TEMPORARY FUEL STORAGE TANK ON SITE.
17. IF "SUMP" PUMPS ARE USED TO REMOVE WATER FROM EXCAVATED AREAS, FILTER THE DISCHARGE TO REMOVE SEDIMENT AND OTHER MATERIALS BEFORE THE WATER LEAVES THE SITE.
18. TO PREVENT DAMAGE TO VEGETATION IN DOWNSTREAM WATER COURSES, LIMIT ANY PROPOSED LIME STABILIZATION OPERATIONS TO THAT WHICH CAN BE MIXED AND COMPACTED BY THE END OF EACH WORK DAY. GEOTEXTILE FABRIC IS NOT EFFECTIVE IN FILTERING LIME SINCE THE GRAIN SIZE IS SMALLER THAN THE OPENING IN THE FABRIC.
19. VEHICLE PARKING AREAS, STAGING AREAS, STOCKPILES, SPOILS, ETC. SHALL BE LOCATED SUCH THAT THEY WILL NOT ADVERSELY AFFECT STORM WATER QUALITY. OTHERWISE, COVERING OR ENCIRCLING THE AREAS WITH PROTECTIVE MEASURES SHALL BE NECESSARY.
20. STORE ALL TRASH AND BUILDING MATERIALS WASTE IN AN ENCLOSURE UNTIL PROPER DISPOSAL AT OFF-SITE FACILITIES.
21. TRACKING OF SEDIMENT OFF SITE BY TRUCK TRAFFIC SHALL BE HANDLED THROUGH REGULAR CLEANING.
22. INSPECTIONS SHALL BE CONDUCTED BY THE PERMITTEE ONCE EVERY 2 WEEKS AND WITHIN 24 HOURS AFTER A STORM EVENT OF 0.5 INCHES OR MORE. THE INSPECTIONS WILL INCLUDE:
  - A. DISTURBED AREAS OF THE SITE THAT HAVE NOT BEEN STABILIZED
  - B. AREAS USED FOR STORAGE OF MATERIALS THAT ARE EXPOSED TO PRECIPITATION
  - C. STRUCTURAL CONTROL MEASURES
  - D. LOCATIONS WHERE VEHICLES ENTER OR EXIT THE SITE
  - E. IDENTIFICATION OF MEASURES THAT NEED TO BE MAINTAINED, MODIFIED OR ADDED TO CORRECT PROBLEMS
23. CONTRACTOR SHALL PREVENT THE DISCHARGE OF BUILDING MATERIALS, LIME, CEMENT, CONCRETE, ASPHALT, AND MORTAR TO THE MS4 OR TO THE WATERS OF THE UNITED STATES.
24. PERMANENTLY STABILIZE EXPOSED SOIL, WITHIN AND ADJACENT TO THE SITE, THAT IS DISTURBED BY VEHICLES, GRADING AND OTHER CONSTRUCTION ACTIVITIES.
25. CONTAIN ALL RUNOFF FROM MATERIAL USED IN SUBGRADE STABILIZATION.
26. MATERIAL STOCKPILES SHALL BE COVERED BY PLASTIC OR SURROUNDED BY EROSION CONTROL STRUCTURES TO CONTROL SEDIMENT RELEASES.

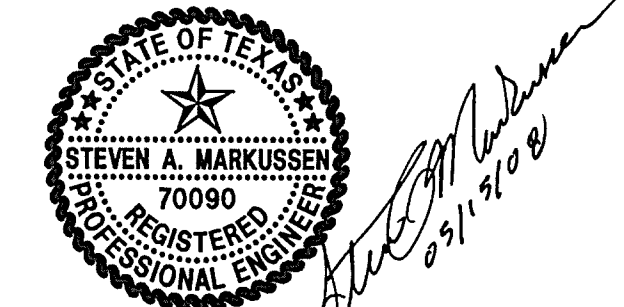

THE SEAL APPEARING ON THIS DOCUMENT WAS AUTHORIZED BY STEVEN A. MARKUSSEN, P.E. 70090 ON 05/15/2008. ALTERATION OF A SEALED DOCUMENT WITHOUT PROPER NOTIFICATION TO THE RESPONSIBLE ENGINEER IS AN OFFENSE UNDER THE TEXAS ENGINEERING PRACTICE ACT.

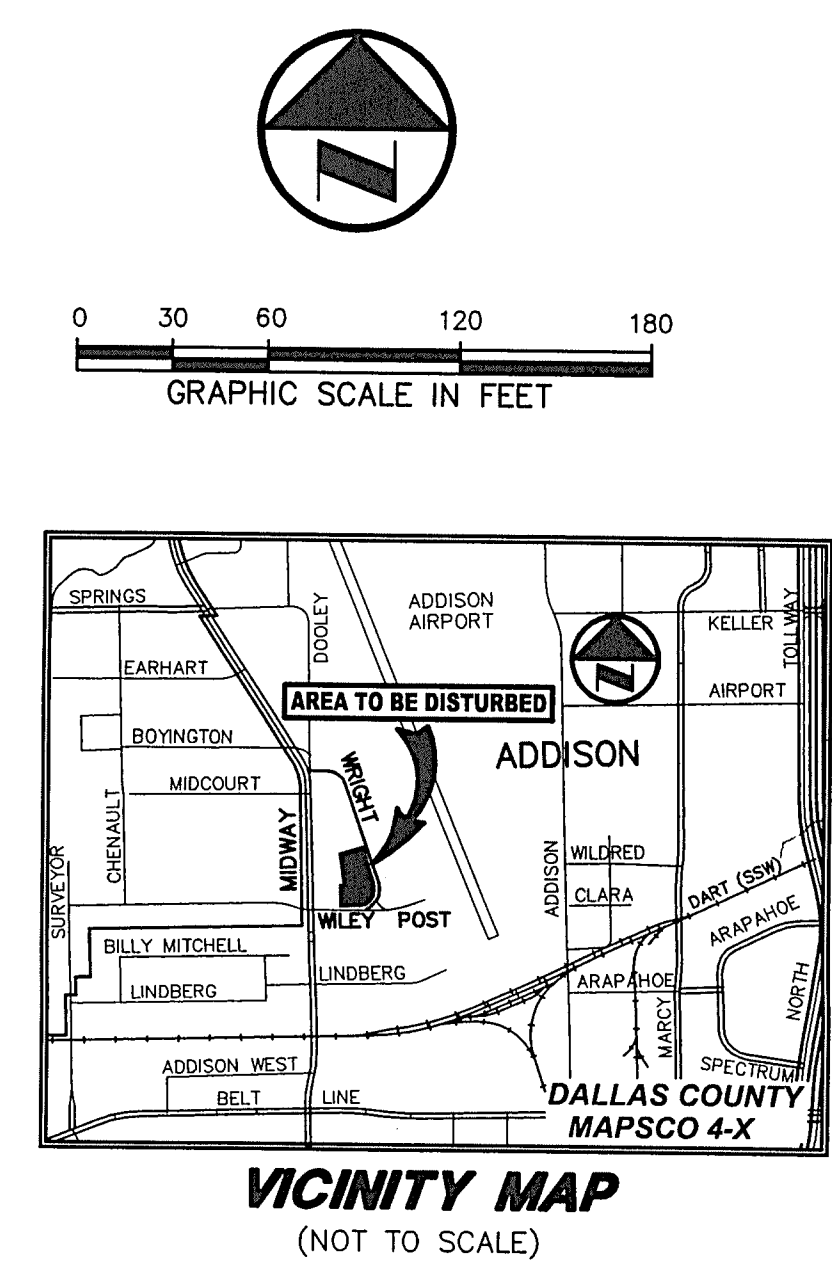

**LEGEND**

B	BOLLARD
EM	ELECTRIC METER
PP	POWER POLE
LS	LIGHT STANDARD
WM	WATER METER
WV	WATER VALVE
ICV	IRRIGATION CONTROL VALVE
FH	FIRE HYDRANT
CO	CLEANOUT
MH	MANHOLE
TSC	TRAFFIC SIGNAL CONTROL
TSP	TRAFFIC SIGNAL POLE
TELE	TELEPHONE BOX
FL	FLOOD LIGHT
FP	FLAG POLE
SIGN	TRAFFIC SIGN
IRS	1/2-INCH IRON ROD W/ "PACHECO KOCH" CAP SET
(C.M.)	CONTROLLING MONUMENT
---	PROPERTY LINE
- - -	FENCE
OH	OVERHEAD UTILITY LINE
E	UNDERGROUND ELECTRIC LINE
T	UNDERGROUND TELEPHONE LINE
C	UNDERGROUND CABLE LINE

**PW# 2007-002**

NO.	DATE	REVISION

**Pacheco Koch Consulting Engineers**  
8350 N. CENTRAL EXP. WY. SUITE 1000 DALLAS, TX. 75206 972.235.3031

**EROSION CONTROL PLAN & DETAILS**

**JW OPERATING - PHASE 1**

**ADDISON AIRPORT INDUSTRIAL DISTRICT**

**LOT 7A, BLOCK B**

**TOWN OF ADDISON, TEXAS**

DESIGN	DRAWN	DATE	SCALE	NOTES	FILE	NO.
CPM	CPM	FEB 2008	1"=60'			<b>C6.1</b>

CONCLUSIVITY  
 05/19/2008 - 8:13PM  
 M:\DWG-27\2792-07.089\DWG\2792-07.089CV-PHASE 1.DWG

JW OPERATING - PHASE 1