

OVERALL DRAINAGE AREA MAP

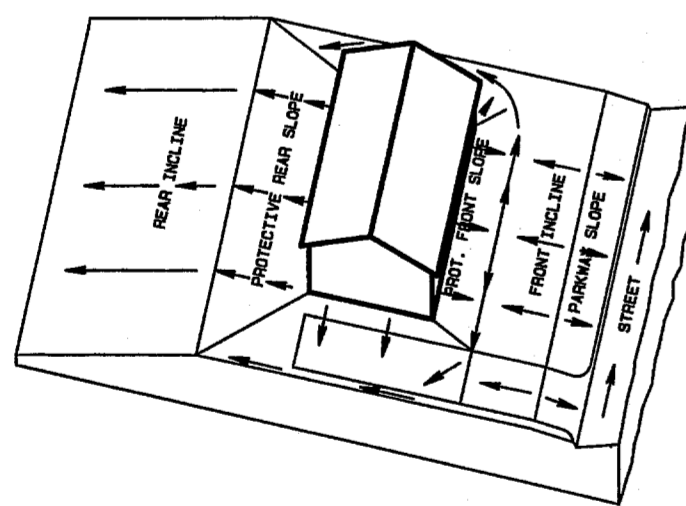

LOT GRADING TYPE C
ALL DRAINAGE TO REAR LOT LINE

- Notes:
1. Contractor must insure that all areas will be graded to drain.
 2. Contractor must field verify all existing utilities prior to construction.
 3. Contractor must notify engineer of any discrepancies between these plans and onsite conditions.

BENCH MARKS
R.R. SPIKE IN 18" PECAN N. SIDE OF BELTLINE RD. STA 52+48 ~ 54" WATER
~ E. OF INWOOD RD. NEAR LAKE FOREST RD. ELEV=568.34

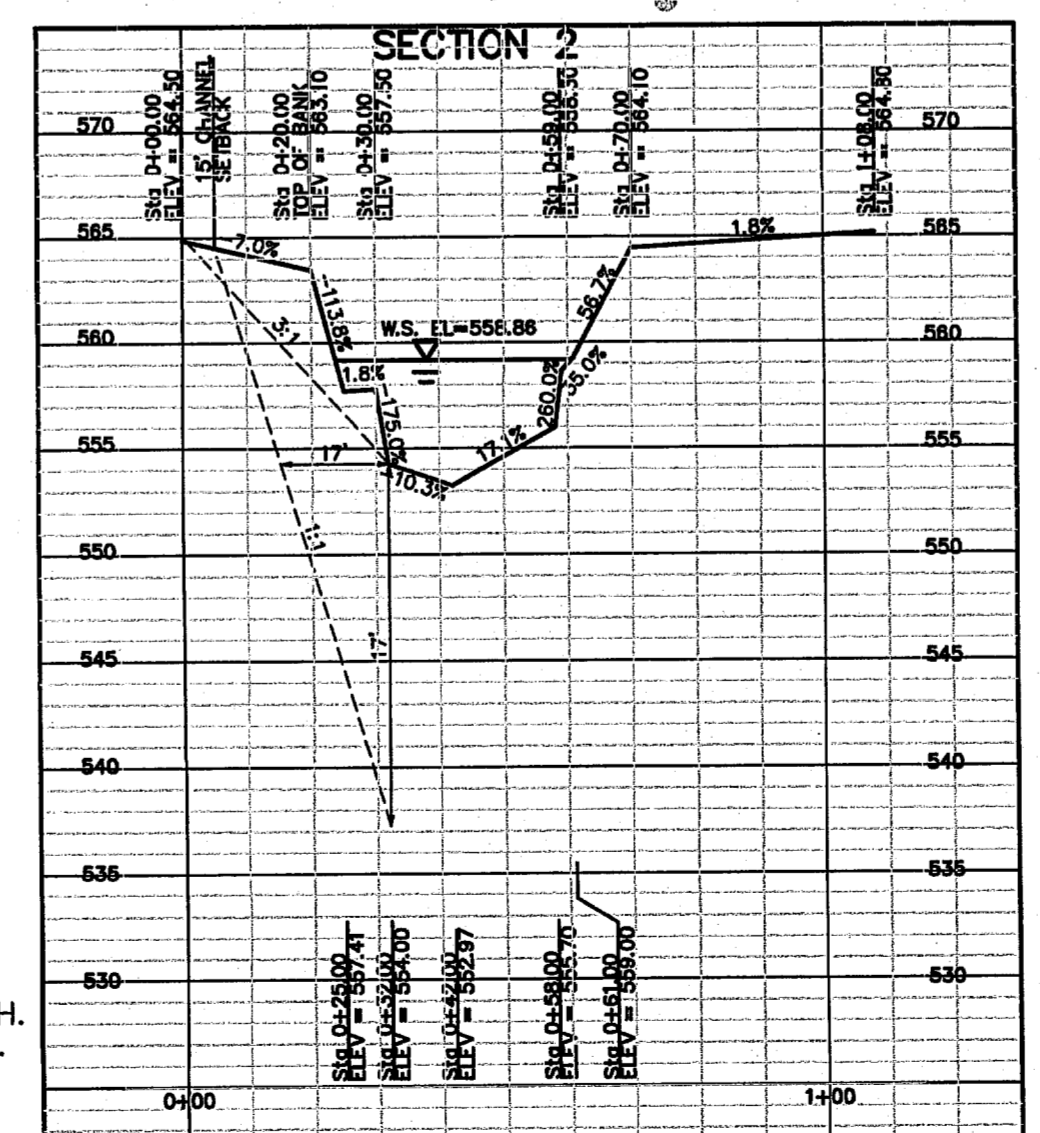
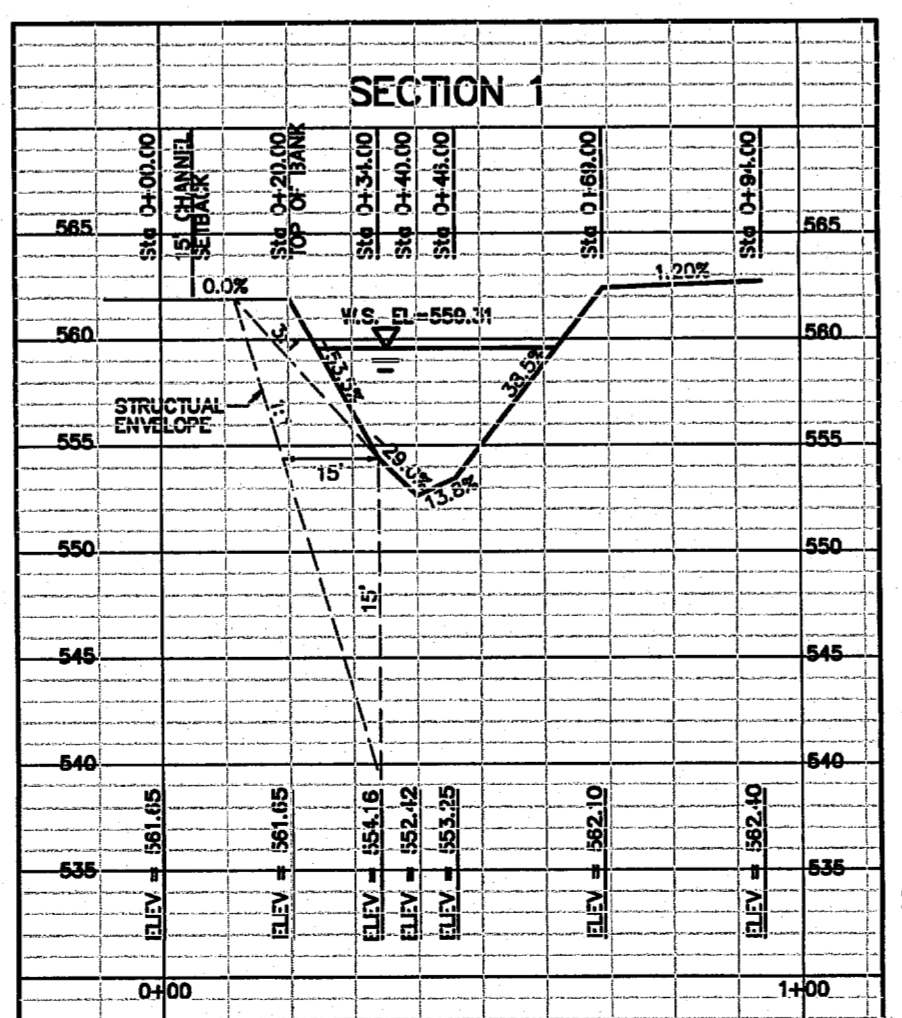
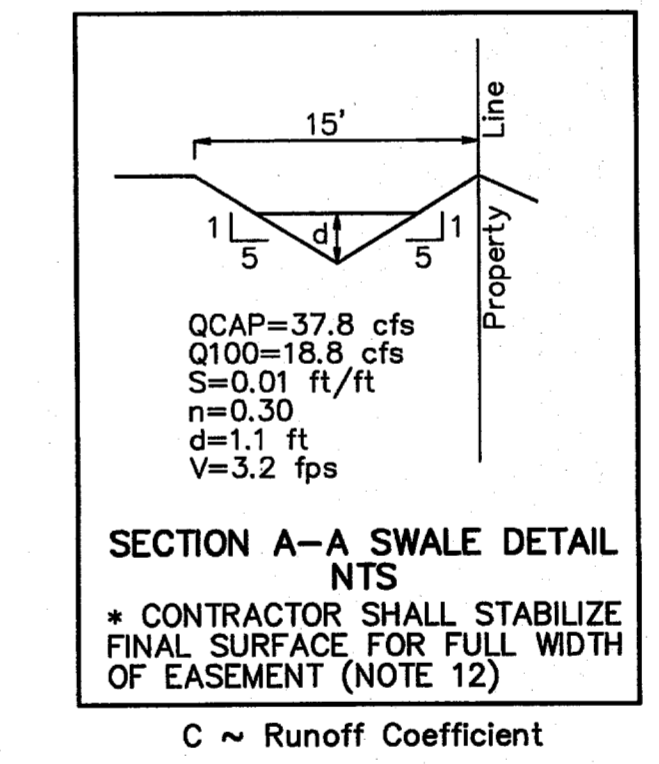
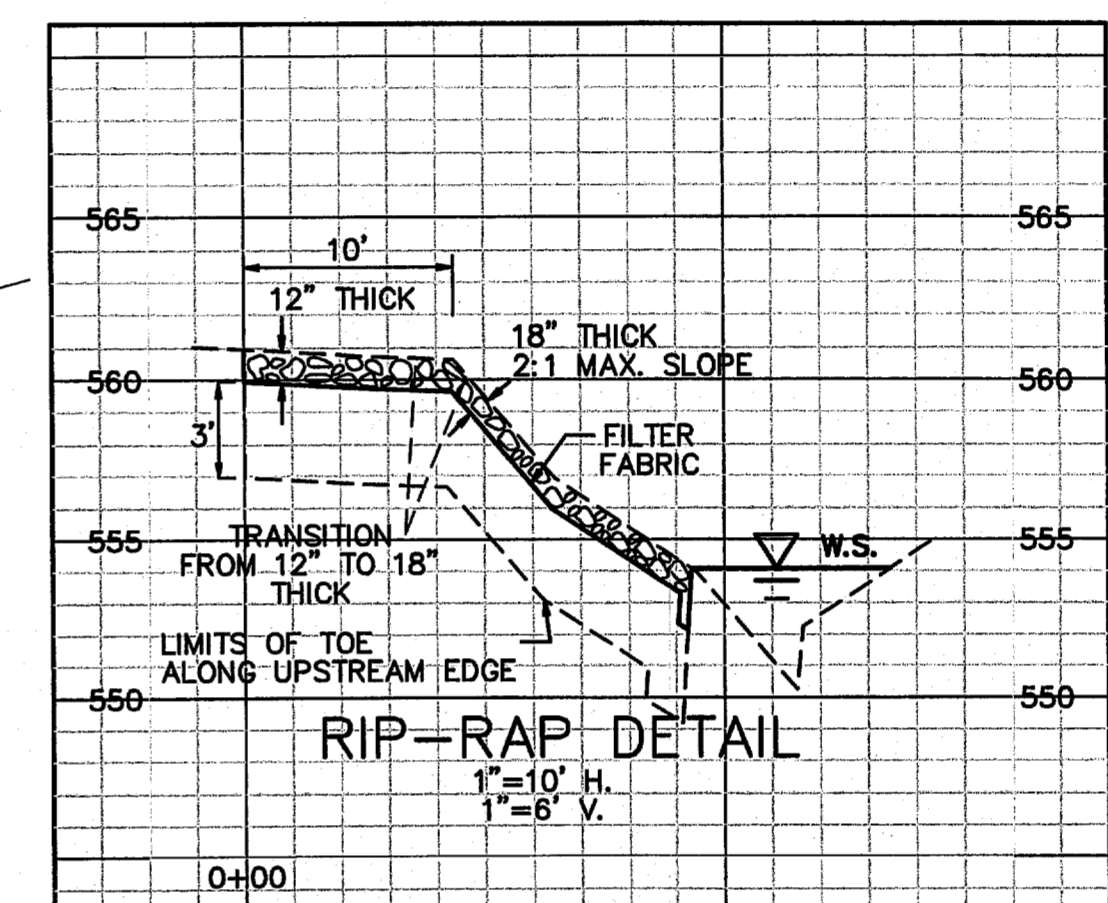
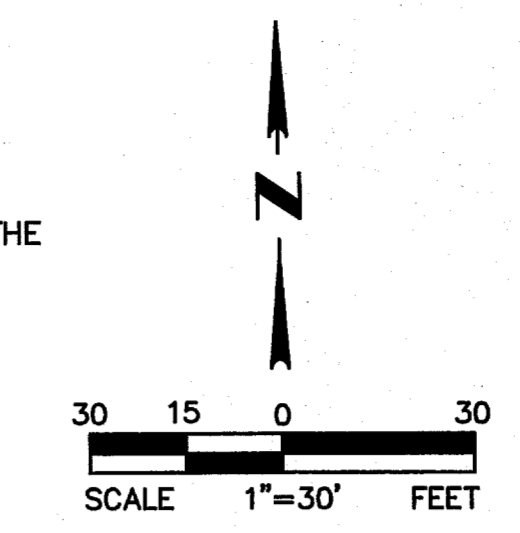
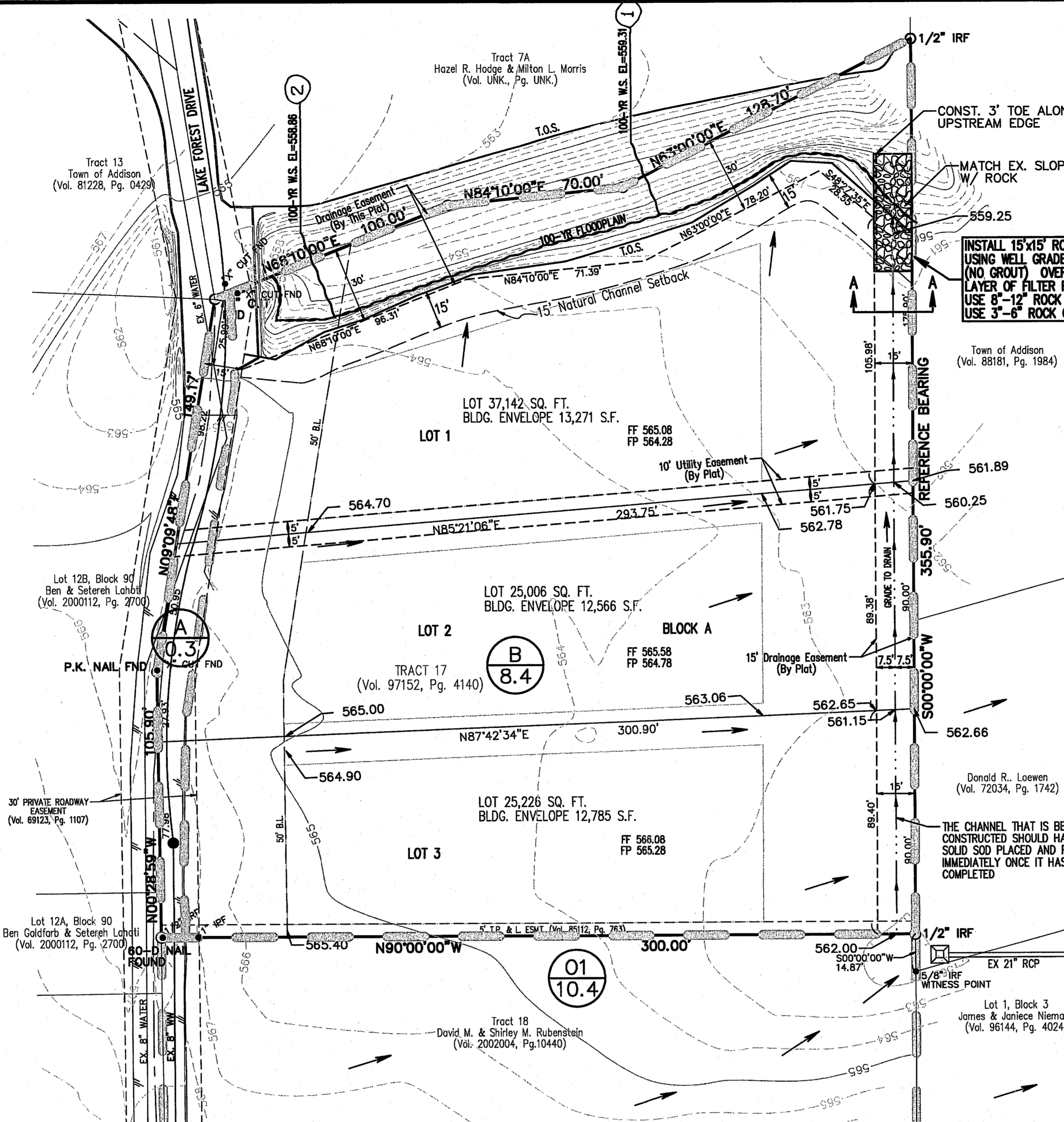
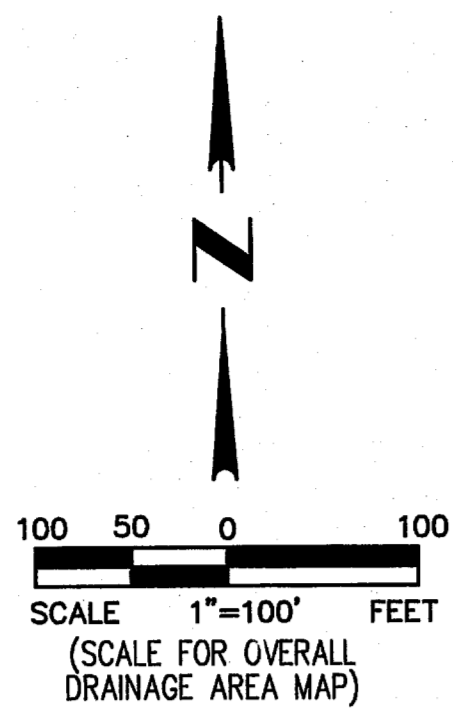

- GRADING NOTES:**
1. Finished floor (FF) elevations shall be at least four feet above the 100-year water surface elevation.
 2. The indicated finished pad (FP) and finished floor (FF) elevations may be adjusted to achieve a dirt balance.
 3. All areas shall be graded to drain as indicated.

LEGEND

- 500 — Existing 5' Contour Interval
- 488 — Existing 1' Contour Interval
- V.G. — Valley Gutter
- — Proposed Drainage Area Divide
- ← — Direction of Flow
- (A1 5.3) — Proposed Area Designation Runoff in C.F.S.
- — Asphalt Pavement

- EARTHWORK NOTES**
1. Site Preparation
All trees, stumps, brush, abandoned structures, roots, vegetation, rubbish and any other undesirable matter should be properly removed and disposed of.
 2. Compacting Area to be Filled
All areas to be filled should be disc'd or bladed until uniform and free from large clods, brought to a moisture content between optimum and five (5) percentage points above the optimum moisture value for clayey soils and between optimum to +3 percentage points for silty clay soils and soil containing limestone fragments and compacted to between 95 and 100 percent of optimum density in accordance with ASTM D 698.
 3. Fill Materials
Off-site materials to be used for fill should be approved by the Soils Engineer. There should be no rocks, vegetation or any other undesirable matter in the soil, and no rocks larger than six (6) inches in diameter.
 4. Depth of Mixing of Fill Layers
The fill material should be placed in level, uniform layers, which, when compacted, should have a moisture content and density conforming to the stipulations called for herein. Each layer should be thoroughly mixed during the spreading to insure the uniformity of the layer. The fill thickness should not exceed 10-inch loose lifts.
 5. Rock
There should be no rock incorporated within the fill which exceeds six (6) inches in its greatest dimension, and no large rocks will be permitted within twelve (12) inches of the finished subgrade.
 6. Moisture Content
Prior to and in conjunction with the compacting operation, each layer should be brought to the proper moisture content as determined by ASTM D 698, within plus or minus three (3) percentage points of optimum for fill containing limestone rock pieces and between optimum and five percentage points above the optimum for clayey soils.
 7. Amount of compaction
After each layer has been properly placed, mixed and spread, it should be thoroughly compacted to between 95 and 100 percent of Standard Proctor Density as determined by ASTM D 698.
 8. Compaction of Fill Layers
Compaction equipment should be of such design that it will be able to compact the fill to the specified density. Compaction of each layer shall be continuous over its entire area.
 9. Density Tests
Field Density tests should be made by the Soils Engineer or his representative. Density tests should be taken in the compacted material below the disturbed surface. After each layer of fill, compaction tests, as necessary, should be made by the Soils Engineer. If the materials fail to meet the density specified, the course should be reworked as necessary to obtain the specified compaction.
 10. Supervision
Supervision by the Soils Engineer should be of such continuity during the grading operation that he can certify that all cut and filled areas were graded in accordance with the accepted specifications.
 11. Slope Control
Embankment slopes should not be steeper than a ratio of three (3) horizontal to one (1) vertical for either fill or cut slopes. Any slope, existing or proposed, steeper than three (3) feet in height should incorporate stabilization methods to include erosion control, embankment stabilization and other slope control measures as required by the slope control specialist.
 12. Contract surface stabilization shall stabilize finished surface with sod or curlex (seed-impregnated) as shown.

RATIONAL METHOD

Q=CIA
Q ~ Flow (c.f.s.)
C ~ Runoff Coefficient
I ~ Intensity (in./hr.)
A ~ Drainage Area (Acres)

RUNOFF CALCULATIONS

AREA	ACRES	C	Ic	I100	Q100	REMARKS
A	0.07	*0.58	15	7.52	0.3	Street to Creek
B	1.94	*0.58	15	7.52	8.4	To Swale
O1	2.76	0.50	15	7.52	10.4	Offsite ~ Into Swale

* Indicates Weighted Coefficient

WEIGHTED RUNOFF COEFFICIENT CALCULATIONS

PADS	AREA	C	CA
	0.82	0.90	0.74
REMAINING ACREAGE	1.18	0.35	0.41
TOTAL	2.00		1.15

WEIGHTED 'C' = $\frac{CA}{AREA} = \frac{1.15}{2.00} = 0.58$



MACATEE ENGINEERING
6440 N. CENTRAL EXPRESSWAY, SUITE 414
DALLAS, TEXAS 75206
TEL 214-378-1180 * FAX 214-378-6580
E-MAIL: contact@macatee-engineering.com

GRADING & DRAINAGE PLAN		PROJECT NO.
LAKE FOREST ADDITION		LD401
TOWN OF ADDISON DALLAS COUNTY, TEXAS		PLATE
		1 of 1

NO.	REVISIONS DURING CONSTRUCTION	BY	DATE	NO.	REVISIONS DURING PLAN REVIEW	BY	DATE

SCALE 1"=30'
DESIGNED PRR
DRAWN PRR
DATE 02/17/06
DWG FILE LD401BAS.PRD