

**APPRAISAL REPORT
BELT LINE ROAD PROJECT
PARCEL 38R
AZURE RESTAURANT AND BAR
4080 BELT LINE ROAD
ADDISON, DALLAS COUNTY, TEXAS**

FOR

**TOWN OF ADDISON
16801 WESTGROVE DRIVE
ADDISON, TEXAS 75001**

**PYLES WHATLEY CORPORATION
11551 FOREST CENTRAL DRIVE, SUITE 220
DALLAS, TEXAS 75243**

PYLES ★ WHATLEY CORPORATION
Real Estate Consultants

Wendell Pyles, MAI, SR/WA

Jan Whatley (1953-2013)

March 31, 2014

Ms. Lisa Pyles
Town of Addison
16801 Westgrove Drive
Addison, Texas 75001

RE: A real estate appraisal of Parcel 38R, a proposed fee simple acquisition in the Belt Line Road Project, located at the southeast corner of Belt Line Road and Runyon Road, Addison, Dallas County, Texas.

Dear Ms. Pyles:

At your request, we submit this appraisal report to estimate the market value of the above referenced property. We have made an on-site inspection of the property and considered factors pertinent to and indicative of value including: Dallas/Fort Worth and Addison area characteristics, market area data and trends, locational amenities, highest and best use, and other elements of value.

Methodology and terminology used throughout the report may be found in *The Appraisal of Real Estate*, 14th Edition, as published by the Appraisal Institute.

The subject property is a tract of land totaling 66,184 square feet, improved with a restaurant, located along Belt Line Road. This appraisal report is in compliance with the Uniform Standards of Professional Appraisal Practice (USPAP) as provided by the Appraisal Foundation. Our opinion of value for the subject is effective as of January 15, 2014.

The appraisal problem, as applied to the subject, is to determine the property's market value and the total compensation due to the property owner for the proposed acquisition. "Market Value is the price which the property would bring when it is offered for sale by one who desires, but is not obliged to sell, and is bought by one who is under no necessity of buying it, taking into consideration all of the uses to which it is reasonably adaptable and for which it either is or in all reasonable probability will become available within the reasonable future." City of Austin v. Cannizzo, 267 S.W. 2d 808 (Tex. 1954).

11551 Forest Central Drive
Suite 220
Dallas, Texas 75243
Phone (214) 340-5880
Fax (214) 340-5422

www.PylesWhatley.com
Toll Free (800) 340-2166

777 Main Street
Suite 600
Fort Worth, Texas 76102
Phone (817) 887-8176
Fax (817) 887-8177

Page 2
 Ms. Lisa Pyles
 March 31, 2014

With reference to the preceding definition, our opinions of value are as follows:

Whole Property (Market Value)	\$	1,400,000	
Part To Be Acquired in Fee Simple			\$ 9,415
Remainder - Before Taking	\$	1,390,585	
Remainder - After Taking	\$	1,390,585	
Costs-to-Cure			\$ 0
Total Compensation	\$		<u>9,415</u>

Any personal property, fixtures, or intangible items that are not real property - that are included in the valuation - are identified as personal property and discussed herein.

The following report sets forth a description of the property along with a summary of the market data considered and the conclusions derived from such data. Your attention is directed to the general assumptions and limiting conditions on the following pages, as well as the extraordinary assumptions and hypothetical conditions.

If you should have questions concerning any portion of this appraisal report, please contact our office.

Respectfully submitted,

PYLES★WHATLEY CORPORATION



Charles Stearman, SR/WA
 State of Texas Certification # TX-1335388-G

SUMMARY OF IMPORTANT FACTS AND CONCLUSIONS

BELT LINE ROAD PROJECT

Parcel Owner	4080 BLR, Ltd.		
Parcel Number	38R		
Location	4080 Belt Line Road Addison, Texas 75001		
Mapsc	DA-14-B		
Whole Property Land Area	1.5194 acres	<i>(or 66,184 SF)</i>	
Part To Be Acquired - Fee Simple	0.0180 acres	<i>(or 783 SF)</i>	
Zoning	PD, Planned Development		
Highest & Best Use	Commercial Use		
Reasonable Exposure Time	12 to 18 months		
Effective Date of the Appraisal	January 15, 2014		
Date of Appraisal Report	March 31, 2014		
Whole Property (Market Value)	\$	1,400,000	
Part To Be Acquired in Fee Simple			\$ 9,415
Remainder - Before Taking	\$	1,390,585	
Remainder - After Taking	\$	1,390,585	
Costs-to-Cure			\$ 0
Total Compensation	\$		9,415

TABLE OF CONTENTS

**LETTER OF TRANSMITTAL
SUMMARY OF IMPORTANT FACTS**

	<u>PAGE</u>
SCOPE OF THE ASSIGNMENT	1
DEFINITION OF MARKET VALUE.....	6
GENERAL ASSUMPTIONS AND LIMITING CONDITIONS.....	7
EXTRAORDINARY ASSUMPTIONS & HYPOTHETICAL CONDITIONS.....	10
MARKET AREA	11
DALLAS/FORT WORTH METROPOLITAN AREA ANALYSIS	12
REGIONAL MAP.....	30
TOWN OF ADDISON ANALYSIS.....	31
SUBJECT VICINITY.....	36
LOCATION MAP.....	40
REAL ESTATE TAX ANALYSIS.....	45
AERIAL PHOTOGRAPH.....	46
SUBJECT PHOTOGRAPHS	47
WHOLE PROPERTY SKETCH	52
HIGHEST AND BEST USE	60
LAND VALUATION.....	62
COST APPROACH.....	71
SALES COMPARISON APPROACH	77
INCOME CAPITALIZATION APPROACH.....	88
RECONCILIATION – WHOLE PROPERTY VALUE.....	104
PART TO BE ACQUIRED.....	106
REMAINDER AFTER TAKING.....	111
SUMMARY OF COMPENSATION.....	113
APPRAISER’S CERTIFICATE	114
APPRAISER QUALIFICATIONS	115

ADDENDA

**TAX INFORMATION
CERTIFIED LETTER
RETURN RECEIPTS**

SCOPE OF THE ASSIGNMENT

Purpose of the Appraisal

The purpose of this appraisal is to estimate the market value of the subject property: the whole property, part to be acquired, remainder property, and any damages to the remainder property. This is an Appraisal Report that is intended to comply with the reporting requirements set forth under Standards Rule 2-2 (a) of the Uniform Standards of Professional Appraisal Practice for an Appraisal Report. As such, it presents summary discussions of the data, reasoning, and analyses that were used in the appraisal process to develop the appraiser's opinion of value. Supporting documentation concerning the data, reasoning, and analyses is retained in the appraiser's file. The depth of discussion contained in this report is specific to the needs of the client and intended user(s) for the intended use stated below. The appraisers are not responsible for unauthorized use of this report.

Client, Intended Use, and Intended User

The Town of Addison is the client of Pyles Whatley Corporation. The intended use of this appraisal is to assist the client in their determination of total compensation due to the property owner - the market value of the property to be acquired and any remainder damages. The intended users are the Town of Addison and Half Associates, Inc. and their officers, employees, and agents. Any other user or uses are not intended or authorized. Use of this appraisal for any other use or by another user or appraisal date may invalidate the findings and conclusions.

The client has been notified that the appraiser has not appraised the subject property in the three years preceding the date of this report.

Effective Date of the Appraisal

The subject property is appraised as of January 15, 2014, the effective date, and is subject to the market influences and economic conditions, which existed on that date. The subject property was inspected on January 15, 2014.

Date of Report: March 31, 2014

Interest(s) Valued Fee Simple Estate

A Fee Simple Estate is definable as absolute ownership, unencumbered by another interest or estate, and subject only to the limitations of eminent domain, escheat, police power, or taxation.

Easement Estate is defined as an interest in real property that conveys use, but not ownership, of a portion of an owner's property.

SCOPE OF THE ASSIGNMENT

Identification of Property

The subject is located in the town of Addison in Dallas County, Texas. The subject tract comprises 66,184 square feet (1.5194 acres) situated at the southeast corner of Belt Line Road and Runyon Road. Physically addressed as 4080 Belt Line Road, Addison, Texas 75001, the subject site is improved with a restaurant, doing business as Azure. Abutting uses are Belt Line Road followed by commercial use along the north side, a restaurant along the east side, Runyon Road followed by a restaurant along the west side, and a hotel along the south side.

The subject is currently used as a restaurant. The property appraised is identified as the subject property as improved.

Legal Description

The subject is legally described as land situated in the Belt Line Center Replat, Block 1, Lot 1, Dallas County, Texas.

Subject History

According to the title commitment provided, the ownership is vested in 4080 BLR, Ltd.. The property transferred to 4080 BLR, Ltd. from Winghouse of Addison, LLC on September 24, 2010, as recorded in Instrument 201000247792, Deed Records of Dallas County, Texas. The price and terms of the transaction are unknown. No other transaction has occurred in the last five years. To our knowledge, the property is not for sale or under a purchase contract. Azure currently occupies the property as a tenant for \$9,701 per month on a triple net basis.

This information is included only to satisfy the requirements of USPAP. It is not intended as a guarantee of title or chain of title.

Part To Be Acquired

The Town of Addison proposes to acquire a part of the subject property for the Belt Line Road Project. The proposed acquisition is in fee simple. The part to be acquired comprises 0.0180 acres, or 783 square feet located at the northwest property corner. The proposed fee simple acquisition amounts to approximately 1.18 percent of the land area ($783 \text{ SF} \div 66,184 \text{ SF} = 0.0118$). The remainder property is 1.501 acres, or 65,401 square feet. Reference the following table.

Whole Property	1.5194 AC	<i>Or</i>	66,184 SF	
Part To Be Acquired in Fee	<u>0.0180 AC</u>	<i>Or</i>	<u>783 SF</u>	<i>Or 1.18% of the Whole Property</i>
Remainder Property	1.5014 AC	<i>Or</i>	65,401 SF	

Inspection Information

We contacted the subject property owner by certified mail. A copy of the letter and return receipt are included in the addenda of this report. The tenant was present at the time of the inspection.

SCOPE OF THE ASSIGNMENT

Project Description

The Belt Line Road Project by the Town of Addison is for the undergrounding of electrical utilities along Belt Line Road, between Marsh Lane and Midway Road, in Addison, Texas. The purpose is to enhance the streetscape. Permanent and temporary easements and fee simple acquisitions are required. The type and use of the acquisitions vary by parcel. The acquisition areas are for electrical utilities and switchgear, drainage facilities, manholes, street right-of-way, landscaping, and sidewalks and crosswalk ramps. The construction date has not been determined.

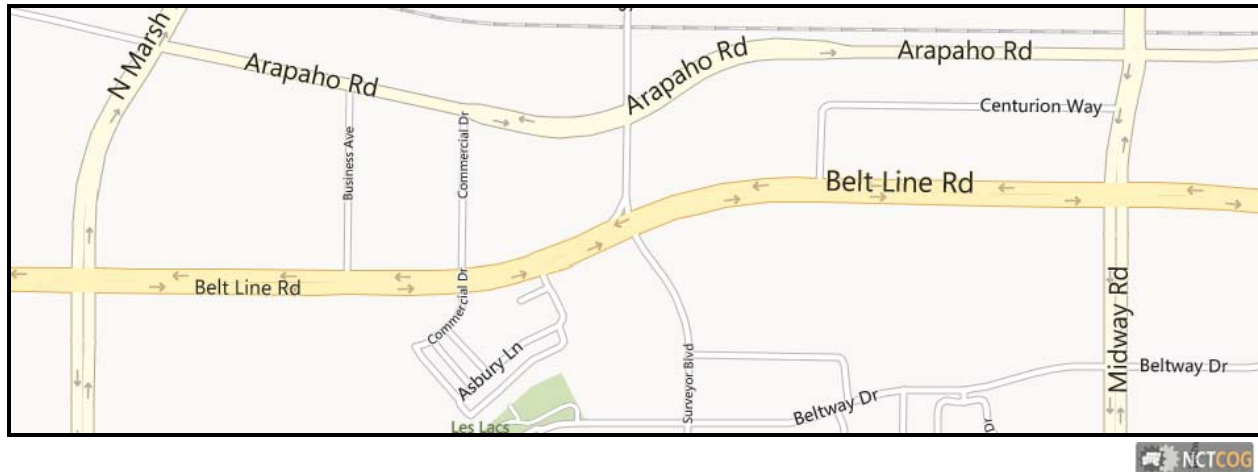

Project Influence

The subject property is appraised excluding consideration of the effect, if any, on value of the whole property and the part to be acquired caused by the proposed public improvements, and excluding any non-compensable damages to the remainder property that result because of the part acquired or the public project. We conclude that the impending project has no effect on the whole property or on the comparable market data used herein.

Appraisal Problem

The appraisal problem, as applied to the subject, is to determine the market value of the fee simple interest in the subject property and determine the total compensation due to the property owner for the proposed acquisition. In addressing this problem, the principles of utility, substitution, and anticipation are considered in the following valuation.

SCOPE OF THE ASSIGNMENT

Data Researched

For this report, the subject market was researched for all pertinent data relating to the appraisal problem including: collecting and confirming data through brokers, appraisers, property owners, lessees/lessors, and others familiar with the real estate market. The information provided by these sources is deemed reliable, but is not guaranteed.

In addition, verifiable third party sources were utilized including the Multiple Listing Service (MLS) and others. Where applicable, additional market data was extracted from market reports and data circulated and purchased from, Real Estate Research Corporation, Price Waterhouse Coopers Korpacz Investor Survey, Yieldstar and others. The information provided by these sources is deemed reliable, but is not guaranteed.

Competency

Collectively, the appraisers involved in this assignment have considerable experience in appraising this property type, and have adequate knowledge of the property type and location to meet the competency requirements of the Uniform Standards of Professional Appraisal Practice. In addition, other appraisers in the market would perform similar actions in the appraisal process to fulfill the scope of work in this assignment and the appraisal meets or exceeds the expectations of parties who are regularly intended users for similar assignments.

Procedure

For this report, the area was inspected and the highest and best use analyzed considering the factors of physically possible, legally permissible, financially feasible, and maximally productive. The cost, sales comparison, and income capitalization approaches are applicable for appraisal purposes and are included in the valuation of the subject. The market was researched for all pertinent land sale data and improved sales and rentals relating to the valuation. These data are analyzed and adjusted using commonly accepted appraisal techniques. The subject land is valued by market comparison of similar tracts of land using the sales comparison approach. Using the cost approach, replacement costs are abstracted from industry sources and applied to the subject improvements, less accrued depreciation. The resulting value indications are reconciled to one final opinion of value of the whole property.

Exposure Time

Exposure time is defined as the estimated length of time the property interest being appraised would have been offered on the market prior to the hypothetical consummation of a sale at market value on the effective date of the appraisal; a retrospective opinion based on an analysis of past events assuming a competitive and open market.

Considering the state of the economy, properties of the subject type, and market participants' actions, an exposure time of 12 to 18 months is concluded for the subject property – at a value consistent with the conclusions of this report.

SCOPE OF THE ASSIGNMENT

Scope of Work

Pyles Whatley Corporation, through its licensed appraisers, Charles Stearman and Jace Whatley, have performed all aspects of the real estate appraisal report, to include the following:

- Identified the property and interests to be appraised;
- Communicated with the Town of Addison personnel, and Halff Associates, Inc. (the design and engineering consultant), and as appropriate, other service providers, and landowners, regarding the appraisal assignment;
- When possible, communicated with the property owner regarding the history and the condition of the subject property;
- Researched the public records for data on the subject property, including zoning, assessments, taxes, acreage, buildings and site improvements, and maps;
- Performed a preliminary search of all available resources to determine market trends, influences and other significant factors pertinent to the subject properties. Inspected the subject property and subject area, and photographed the subject and relevant comparable sales and income properties; although due diligence has been exercised in inspection of the properties, the appraiser is not an expert in such matters as soils, structural engineering, hazardous waste, environmental conditions, the ADA, and other similar matters, and no warranty is given as to these elements;
- Performed an analysis of the highest and best use of the subject property;
- Researched and collected relevant data (improved sales, escrow sales, listings, and income and other market data) as present in the market area (from public and private sources) and of sufficient quality to express an opinion of value as defined in the appraisal reports;
- Gathered and analyzed the market data to reach an estimate of market value for the appropriate interest in the subject, using the methodology and valuation approaches that are relevant to the assignment;
- Assembled and wrote the narrative report, complete with maps, photos, and supporting addenda;
- Prepared and submitted a written appraisal report of the property, as requested by the client;
- A narrative appraisal report meets the client's requirements.

DEFINITION OF MARKET VALUE

The definition of market value is:

“Market Value is the price which the property would bring when it is offered for sale by one who desires, but is not obliged to sell, and is bought by one who is under no necessity of buying it, taking into consideration all of the uses to which it is reasonably adaptable and for which it either is or in all reasonable probability will become available within the reasonable future.” *City of Austin v. Cannizzo*, 267 S.W. 2d 808 (Tex. 1954).

In this report, a market value opinion of the fee simple interest in the real property is developed.

GENERAL ASSUMPTIONS AND LIMITING CONDITIONS

The Uniform Standards of Professional Appraisal Practice and the Code of Professional Ethics and Standards of Professional Practice of the Appraisal Institute require the appraiser to "set forth all assumptions and limiting conditions that affect the analyses, opinions, and conclusions in the report". In compliance therewith, and to assist the reader in interpreting this report, such general assumptions and limiting conditions are set forth below. Specific assumptions, if any, are referred to in the transmittal letter and their location in the report detailed.

Title is assumed to be marketable and free and clear of all liens and encumbrances, easements, and restrictions except those specifically discussed in the report. The property is appraised assuming it to be under responsible ownership and competent management and available for its highest and best use.

No opinion is intended to be expressed for legal matters or that would require specialized investigation or knowledge beyond that ordinarily employed by real estate appraisers, notwithstanding the fact that such matters may be discussed in the report.

No opinion is expressed on the value of subsurface oil, gas, water, or mineral rights or whether the property is subject to surface entry for the exploration or removal of such except as expressly stated.

The date of value to which the opinions expressed in this report apply is set forth in the letter of transmittal. The appraiser assumes no responsibility for economic or physical factors occurring at some later date, which may affect the opinions herein stated. The opinion of value is considered reliable only as of the date of the appraisal.

The valuation is reported in dollars of U.S. currency prevailing on the date of the appraisal.

Maps, plats, and exhibits included herein are for illustration only as an aid in visualizing matters discussed within the report. They should not be considered as surveys or relied upon for any other purpose unless specifically identified as such.

All information and comments pertaining to this and other properties included in the report represent the personal opinion of the appraiser, formed after examination and study of the subject and other properties. While it is believed the information, estimates and analyses are correct, the appraiser does not guarantee them and assumes no liability for errors in fact, analysis or judgment.

Neither all nor any part of the contents of this report (especially any conclusions as to value, the identity of the appraiser or the firm with which he is connected, or any reference to the Appraisal Institute or to the MAI or SRA designation) shall be disseminated to the public through advertising media, public relations media, sales media, or any other public means of communication without written consent and approval of the undersigned.

GENERAL ASSUMPTIONS AND LIMITING CONDITIONS

The appraiser is not required to give testimony or to appear in court by reason of this appraisal, unless prior arrangements have been made.

The distribution of the total valuation in this report between land and improvements applies only under the existing, or proposed/completed program of utilization. The separate valuations for land and buildings must not be used in conjunction with any other appraisal and are invalid if so used.

Certain information concerning market and operating data were obtained from others. This information is verified and checked, where possible, and is used in this appraisal only if it is believed to be accurate and correct. However, such information is not guaranteed.

Opinions of value contained herein are opinions only. There is no guarantee, written or implied, that the subject property will sell for such amounts. Prospective values are based on market conditions as of the effective date of the appraisal. The appraiser is not responsible if unforeseeable events alter market conditions subsequent to the effective date of the appraisal. As a personal opinion, valuation may vary between appraisers based on the same facts.

If the subject of the appraisal is an improved property, the appraiser has personally inspected the property (unless otherwise stated) and finds no obvious evidence of structural deficiencies except as stated in this report; however, no responsibility for hidden defects or conformity to specific governmental requirements, such as fire, building and safety, earthquake, or occupancy codes can be assumed without provision of specific professional or governmental inspections. While the general conditions of the property were observed, no guarantee can be made concerning the individual components of the structures including but not limited to the heating system, plumbing, electrical services, roof, possible termite damage or building foundation, wells or septic systems. This appraiser is not qualified to make a complete physical inspection of the property. Such an inspection is beyond the scope of this report and no statements can be made concerning the adequacy or condition of these or other systems.

No investigation - unless presented in other sections of this report - was made by the appraiser to determine if asbestos, fiberglass, or synthetic mineral fiber products are present in improved properties. The existence of such products, if any, would have to be determined by a qualified inspector. It is assumed that there is no asbestos, fiberglass, synthetic mineral fiber products, nor other contaminants present that would materially affect value.

The Americans with Disabilities Act (ADA) became effective January 26, 1992. I have not made a specific compliance survey and analysis of this property to determine whether or not it is in conformity with the various detailed requirements of the ADA. It is possible that a compliance survey of the property together with a detailed analysis of the requirements of the ADA could reveal that the property is not in compliance with one or more of the requirements of the act. If so, this fact could have a negative effect upon the value of the property. Since I have no direct evidence relating to this issue, I did not consider possible noncompliance with the requirements of ADA in estimating the value of the property.

GENERAL ASSUMPTIONS AND LIMITING CONDITIONS

No investigation - unless presented in other sections of this report - was made by the appraiser to determine if any toxic materials are present on the subject tract. The existence of such materials, if any, would have to be determined by a qualified inspector. It is assumed that no toxic materials are present that would materially affect value or development costs.

A reasonable investigation was made to determine the existence of any underground storage tanks (UST) on the subject site. If USTs are present on the subject site details are provided in other sections of this report. It is assumed there are no USTs present that would materially affect value.

In the event the appraisal is based upon proposed improvements, it is assumed that the improvements will be completed in substantial conformity with plans and specifications, which have been furnished to the appraiser, and with good materials and workmanship. It is also assumed that the proposed foundation and construction techniques are adequate for the existing sub-soil conditions.

Any personal property, fixtures, or intangible items that are not real property, that are included in the valuation- are identified as personal property and discussed herein.

Any personal property, fixtures, or intangible items that are not real property, that are included in the valuation, are identified as personal property and discussed herein.

Due to the multiplicity of mathematical calculations used in standard appraisal practice, rounded values, e.g., rounded to whole dollars or whole units of measure such as linear feet or square feet, may result in inexact sums of components. The typical difference in such cases does not materially affect the value conclusions of this appraisal report or the total compensation due to the property owner.

EXTRAORDINARY ASSUMPTIONS/HYPOTHETICAL CONDITIONS

Extraordinary Assumptions/Hypothetical Conditions: The Uniform Standards of Professional Appraisal Practice require the disclosure of hypothetical conditions and extraordinary assumptions when employed in the development of an appraisal. The use of these may have affected the assignment results.

As defined in the Uniform Standards of Professional Appraisal Practice, an extraordinary assumption is “an assumption, directly related to a specific assignment, as of the effective date of the assignment results, which, if found to be false, could alter the appraiser’s opinions or conclusions.”

As defined in the Uniform Standards of Professional Appraisal Practice, a hypothetical condition is “a condition, directly related to a specific assignment, which is contrary to what is known by the appraiser to exist on the effective date of the assignment results, but is used for the purpose of analysis.”

The subject is appraised conditioned upon the following:

In the remainder condition the subject is appraised as though the Town of Addison project is complete and in place and the part acquired has been put to the use for which it was acquired.

The subject site is located along Belt Line Road and Runyon Road. Adequate, legal access to the subject is assumed available as of the appraisal date.

Within the acquisition area is a sign easement benefitting the southern abutting Hilton Garden Inn. The easement area is improved with a monument sign that is fully within the part to be acquired. The Town of Addison has indicated that the sign will be allowed to stay within the acquisition area. We assume that the Town will grant easement rights to Equinox Hotel Addison, LLC. The monument sign is excluded from the appraisal.

A legal opinion of the deed covering the subject property is not available. It is assumed that the deed does not contain any right, restriction, or reservation that would affect the value conclusions of this report.

The above are set forth for appraisal purposes and no legal reasoning is intended. The reader should be aware that in the event any of the above proves false or improperly applied, the conclusions of this appraisal could be changed or invalidated.

MARKET AREA

A market area, as defined in The Dictionary of Real Estate Appraisal, 5th Edition, copyrighted 2010, is:

"The area associated with a subject property that contains its direct competition."

When analyzing value influences, the focus is on market area. A market area is defined in terms of the market for a specific category of real estate and thus, is the area in which alternative, similar properties effectively compete with the subject property in the minds of probable, potential purchasers and users. A market area can encompass one or multiple neighborhoods or districts.

Market Area Influences

The subject property is located in the town of Addison, Texas, situated in the Dallas-Fort Worth metropolitan area. The market area is considered to be the town of Addison, and the surrounding cities of Carrollton, Farmers Branch, and Dallas, and ultimately the Dallas Fort Worth Metropolitan area as the subject property competes with similar properties in this trade area. An area analysis and a subject vicinity description are presented in the following pages.

DALLAS/FORT WORTH METROPOLITAN ANALYSIS

The subject property in this report is located in the Dallas/Fort Worth Metropolitan Area, one of the major financial and population centers in the nation. Therefore, an overview of the Metroplex is appropriate.

Downtown Dallas

Fort Worth



Photograph Courtesy of the Dallas Convention & Visitors Bureau

CLASSIFICATION

The classifications represented in the Dallas/Fort Worth area are:

Metropolitan Statistical Area (MSA) and Metropolitan Division (MD)

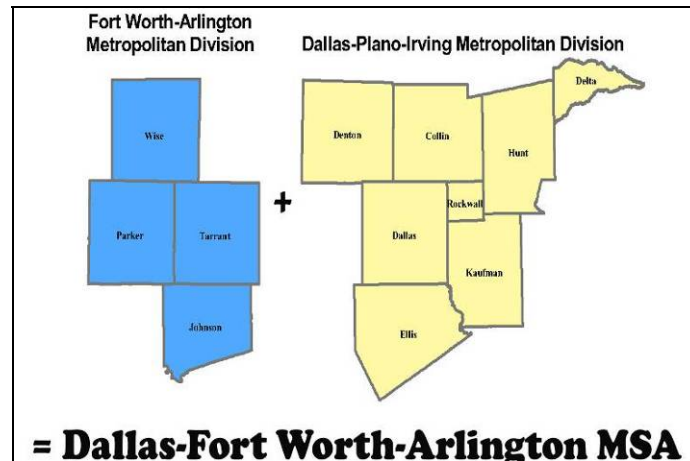

With a population of over 6.4 million, Dallas/Fort Worth and the surrounding area is the fourth largest MSA under this classification. The DFW MSA is comprised of two Metropolitan Divisions; Dallas-Plano-Irving or Dallas MD on the east and Fort Worth-Arlington or Fort Worth MD on the west. The Dallas MD includes Collin, Dallas, Delta, Denton, Ellis, Hunt, Kaufman, and Rockwall Counties with a 2013 estimated population of over 4.3 million. The Fort Worth MD is comprised of Johnson, Parker, Tarrant, and Wise Counties with a 2013 estimated population of over 2.3 million.

DALLAS/FORT WORTH METROPOLITAN ANALYSIS

CITY AND COUNTY CHARACTERISTICS

History/Introduction

The city of Dallas, located in Dallas County, began as a small Trinity River settlement founded in 1841 by John Neely Bryan. Shortly after its founding, Dallas became part of the wagon train route, the Central National Highway of the Republic of Texas. Dallas was incorporated in 1857 despite its small population, and by 1870 had a population of only 2,960.

In the 1870's, Dallas citizens, bent on making their mark in the Southwest, coaxed the Houston & Texas Central Railroad, which ran north/south, and the westbound Texas Pacific Railroad to the city, thereby becoming a crossing point for the Northeast and Southwest.

With the advent of the railroad, Dallas quickly grew to 38,500 by 1890, and by 1920 the nation was referring to Dallas as "Big D". The city's growth has been mostly attributable to the efforts and influences of the business and private sector. Dallas became the center of finance and business in the Southwest when it petitioned for and received one of the twelve District Federal Reserve Banks in 1913. Since that time, Dallas has become the fifth largest financial center in the United States.

Situated in North Texas, Dallas and Fort Worth serve as the principal cities of the DFW metropolitan area (commonly called the Metroplex). Dallas is the main economic center while Fort Worth is the second largest cultural and economic center of the Metroplex.

Demographics/Population

The DFW MSA is the fourth largest metro area in the nation and larger than 33 US states. Dallas is the third largest city in Texas and ninth in the nation. Dallas County is the ninth most populous county in the nation at 2,385,990 persons. Within the Dallas MD is an estimated 2012 population of 4,298,130. Fort Worth ranks as the fifth largest city in the state of Texas and eighteenth in the United States. The city serves as the county seat for Tarrant County which consists of a 2012 population of 1,831,230. Within the Fort Worth MD is a population count of 2,163,280.

From 2000 to 2008, the Dallas-Fort Worth-Arlington MSA was second only to the Atlanta region in growth nationwide. With a growth rate of 2.7%, the MSA population increased by an estimated 947,907 persons.

The Dallas MD experienced a growth rate of 24.5% between 2000 and 2012, indicating slightly lower growth than in the Fort Worth MD which experienced a 26.5% growth rate. Over the past twelve years the MSA as a whole has grown in population by 25.2%.

DALLAS/FORT WORTH METROPOLITAN ANALYSIS

The breakdown of growth by the four major counties of the MSA are as follows:

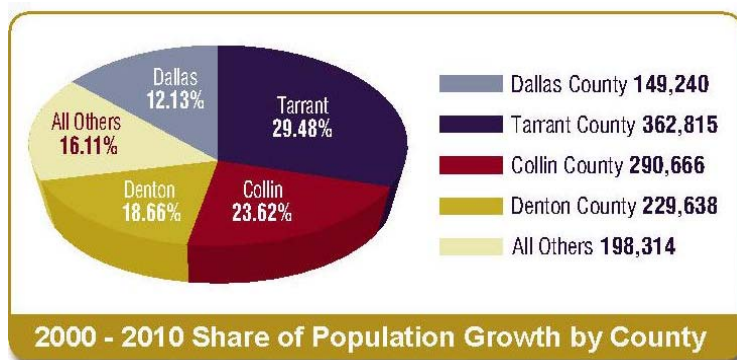

Dallas/Fort Worth also ranks sixth in the nation in terms of urbanized land area. The urbanized area that includes the two cities and their contiguous suburbs consumed 1,407 miles of open land between 1990 and 2000 and grew by more than one-third.

Urban Area (1990-2000)	Total Area (square miles)	Urban Area (1990-2000)	Total Area (square miles)
New York	3,353	Dallas/Fort Worth	1,407
Los Angeles	1,859	Boston	1,736
Chicago	2,123	Washington DC	1,157
Philadelphia	1,799	Detroit	1,261
Miami	1,116	San Francisco	758

The subsequent table illustrates growth trends, in total numbers and annualized percentages, of all the major cities, suburbs, and statistical regions from 1990 to 2012.

DALLAS/FORT WORTH METROPOLITAN ANALYSIS

POPULATION						
ANNUALIZED GROWTH RATES						
AREA	1990	2000	2010	2011	2012	2011-2012 Percent Change
DFW MSA	3,885,415	5,161,544	6,366,542	6,409,700	6,461,410	0.8
Dallas MD	2,553,362	3,451,226	4,230,520	4,262,910	4,298,130	0.8
Collin County	264,036	491,675	782,341	792,150	804,390	1.5
Dallas County	1,852,810	2,218,899	2,368,139	2,380,510	2,385,990	0.2
Denton County	273,525	432,976	662,614	669,930	683,010	2.0
Ellis County	85,167	111,360	149,610	151,030	152,580	1.0
Hunt County	64,343	76,596	86,129	86,860	87,290	0.5
Kaufman County	52,220	71,313	103,350	103,440	104,600	1.1
Rockwall County	25,604	43,080	78,337	78,990	80,270	1.6
Fort Worth MD	1,361,034	1,710,318	2,136,022	2,146,790	2,163,280	0.8
Johnson County	97,165	126,811	150,934	151,440	153,060	1.1
Parker County	64,785	88,495	116,927	117,570	118,860	1.1
Tarrant County	1,170,103	1,446,219	1,809,034	1,818,240	1,831,230	0.7
Wise County	34,679	48,793	59,127	59,540	60,130	1.0
Addison	8,783	13,250	13,056	13,060	13,680	4.7
Allen	18,309	43,554	84,246	84,820	86,600	2.1
Arlington	261,721	322,969	365,438	365,530	365,860	0.1
Carrollton	82,169	109,576	119,097	119,360	121,150	1.5
Coppell	16,881	35,958	38,659	38,870	38,950	0.2
Dallas	1,006,877	1,188,580	49,047	49,210	49,540	0.7
Denton	66,270	80,537	113,383	114,520	115,810	1.1
Duncanville	35,008	36,081	38,524	38,600	38,610	0.0
Farmers Branch	24,250	27,508	28,616	28,600	28,620	0.1
Fort Worth	447,619	534,694	741,206	748,450	757,810	1.3
Frisco	6,138	33,714	116,989	121,670	125,500	3.1
Garland	180,650	215,768	226,876	227,670	228,060	0.2
Grand Prairie	99,616	127,427	175,396	176,320	176,980	0.4
Irving	155,037	191,615	216,290	218,080	218,850	0.4
Lewisville	46,521	77,737	95,290	95,430	96,000	0.6
McKinney	21,283	54,269	131,117	133,010	136,180	2.4
Mesquite	101,484	124,523	139,824	139,890	139,950	0.0
Murphy	1,547	3,109	17,708	17,860	18,020	0.9
Plano	128,713	222,030	259,841	260,500	261,900	0.5
Richardson	74,840	91,802	99,223	99,870	100,450	0.6
Wylie	8,716	14,965	41,427	42,040	42,690	1.5

Source: North Central Texas Council of Governments

DALLAS/FORT WORTH METROPOLITAN ANALYSIS

EMPLOYMENT AND ECONOMIC BASE

DFW MSA Employment

From 1995 to 2000, the DFW MSA was consistently one of the leaders in new job creation, with annual gains in the range of 70,000 to 125,000 jobs. However, the region posted job losses totaling 36,500, or -1.3% decline for the year ending 2001, primarily due to layoffs in the high tech and telecom sectors. This was a record loss and twice the previous record of 19,500 job losses in 1991. In total, only three years of negative job growth are recorded in the last fifteen years. Employment bases of the MSAs are growing and the unemployment figures are typically slightly superior to the U.S. as a whole. Total nonfarm employment in the Dallas-Fort Worth-Arlington Metropolitan Statistical Area stood at 3,114,800 in July 2013, up 111,800 over the year, the U.S. Bureau of Labor Statistics reported. From July 2012 to July 2013, local nonfarm employment rose 3.7 percent, more than twice the national increase of 1.7 percent. Regional Commissioner Stanley W. Suchman noted that among the 12 largest metropolitan areas in the country, Dallas ranked first in the rate of job growth.

Chart 1. Total nonfarm employment, over-the-year net change in the Dallas metropolitan area and its divisions, October 2008–October 2013

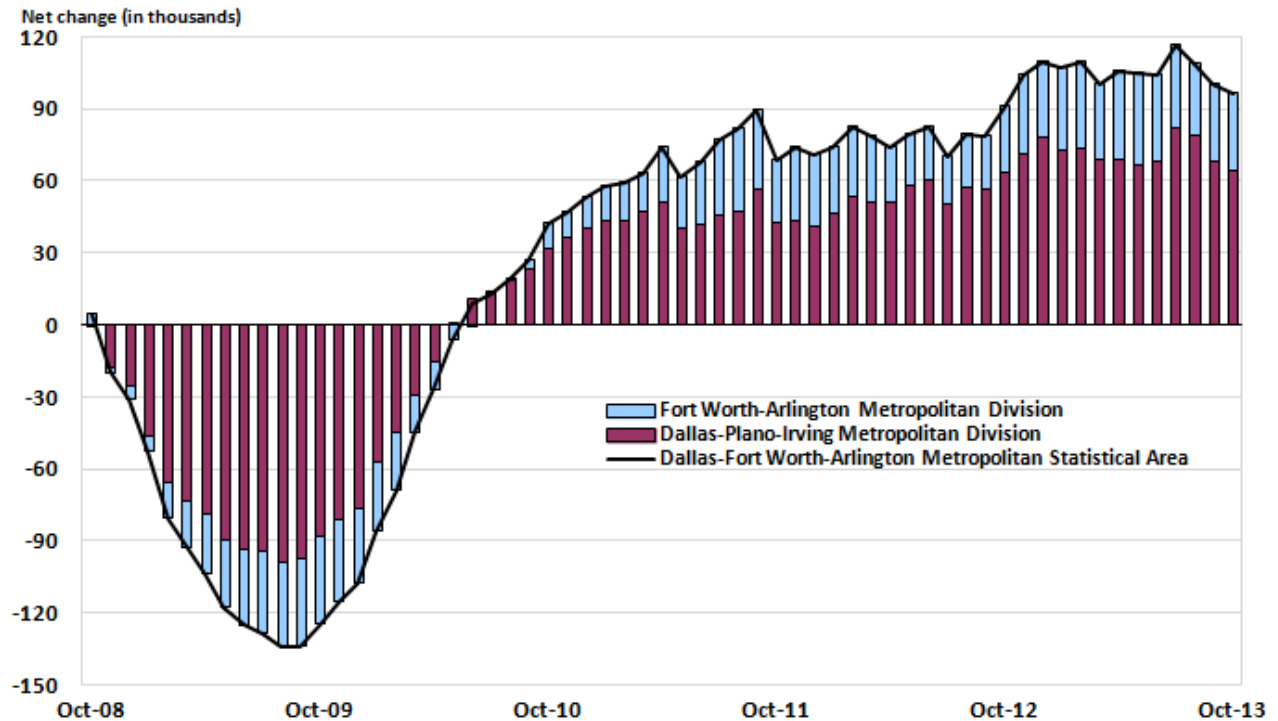

DALLAS/FORT WORTH METROPOLITAN ANALYSIS

Dallas-Fort Worth-Arlington was 1 of the nation's 12 largest metropolitan statistical areas in July 2013. All of these areas experienced over-the-year job growth during the period, with five exceeding the national average of 1.7 percent. The fastest rate of job growth was registered in Dallas, up 3.7 percent, closely followed by Houston-Sugar-Land-Baytown, up 3.6 percent.

Civilian Employment (In Thousands)

August 2013

United States	144,509,000	State of Texas	11,981.9
Abilene	80.1	Longview	111.1
Amarillo	127.4	Lubbock	139.8
Austin-Round Rock-San Marcos	931.1	McAllen-Edinburg-Mission	277.6
Beaumont-Port Arthur	169.4	Midland	92.6
Brownsville-Harlingen	146.1	Odessa	84.1
Bryan-College Station	107.3	San Angelo	53.8
Corpus Christi	208.9	San Antonio-New Braunfels	968.9
Dallas-Plano-Irving MD	2,150.5	Sherman-Denison	54.3
El Paso	293.7	Texarkana	59.0
Fort Worth-Arlington MD	1,077.6	Tyler	95.5
Houston-Baytown-Sugarland	2,916.2	Victoria	58.7
Killeen-Temple-Fort Hood	159.1	Waco	110.2
Laredo	94.8	Wichita Falls	66.7

Source: Texas Workforce Commission -Texas Labor Market Review, September 2013

Chart 3. Over-the-year percent change in employment, United States and 12 largest metropolitan areas, October 2013

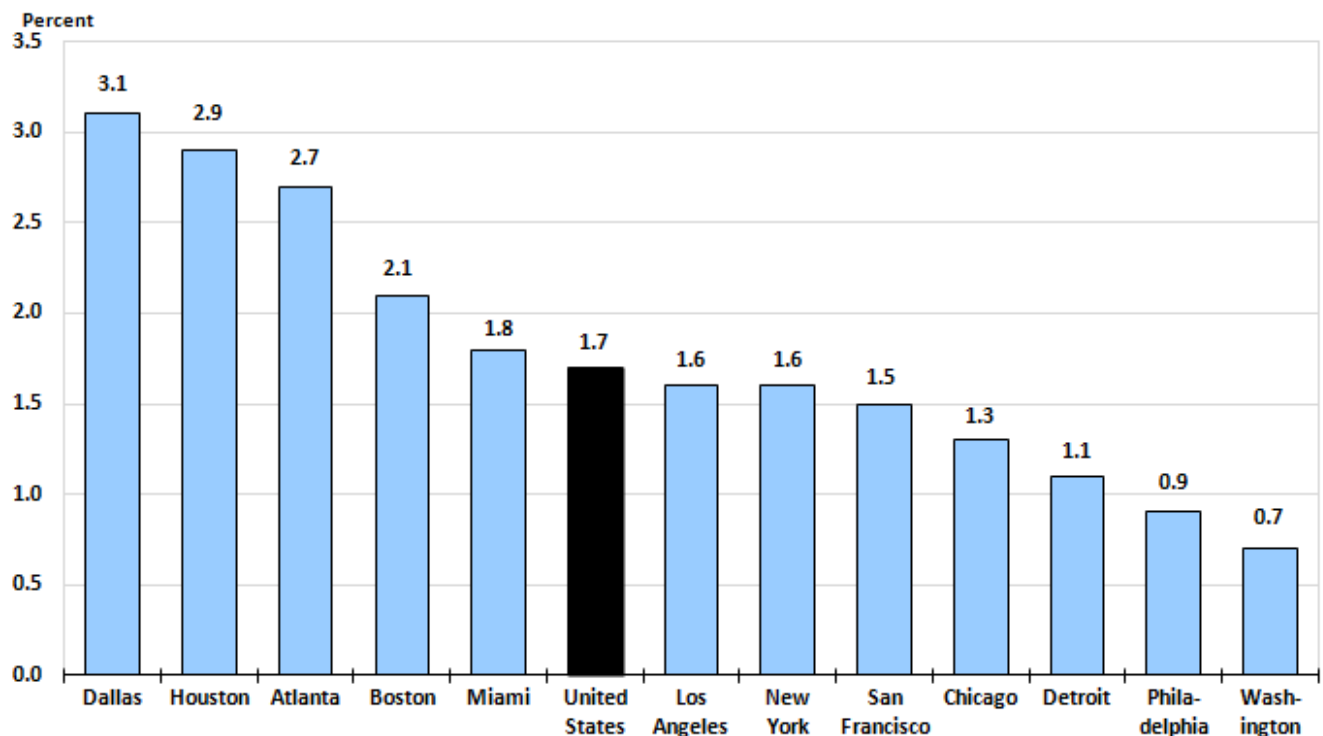

Source: U.S. Bureau of Labor Statistics.

DALLAS/FORT WORTH METROPOLITAN ANALYSIS

In previous years, the DFW diversified economic base has generated employment opportunities, which caused substantial amounts of growth and expansion. The Dallas/Fort Worth job market has changed from a traditional manufacturing and low-skill employment to the service, high tech, and high skill employment. The subsequent chart illustrates employment growth in industry sectors in Dallas/Fort Worth and nationwide.

Chart 2. Over-the-year percent change in employment by industry supersector, United States and the Dallas-Fort Worth-Arlington metropolitan area, October 2013

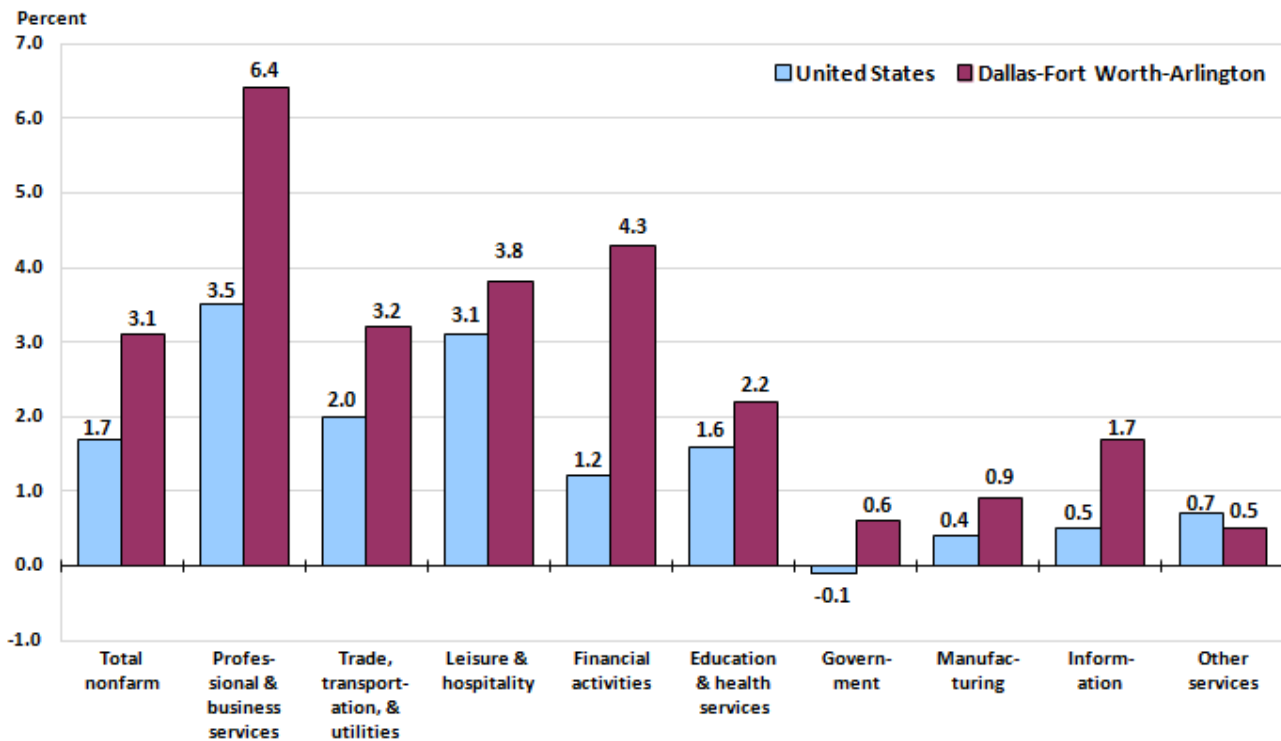

Trade, professional, business, and other services, manufacturing, and government make up the bulk of the jobs within the Dallas/Fort Worth area.

Local Companies

The metropolitan area boasts a long list of national and international corporate headquarters, with many major companies relocating to DFW in the past twenty years. The availability of reasonably priced land, lower living cost for employees, favorable climate, and reasonable housing are great incentives.

DFW MSA is home to 19 Fortune 500 Companies. These companies include Exxon Mobil, AT&T, AMR Corporation, Texas Instruments, Fluor, Kimberly-Clark, J.C Penney, Energy Transfer Holdings, Energy Transfer Equity, Atmos Energy, and several others.

DALLAS/FORT WORTH METROPOLITAN ANALYSIS

The largest North Texas private companies based on revenue include 7-Eleven, Inc., Energy Future Holdings, Michaels Stores Inc., Baylor Health Care System, The Neiman Marcus Group, Texas Health Resources, Glazers Distributors, Sammons Enterprises, Sabre Holdings, and Mary Kay Inc.

Below are the top ten private-sector employers located in North Texas:

Dallas/Fort Worth	
Top Ten Employers	of Local Employees
American Airlines	24,700
Bank of America	20,000
Texas Health Resources	19,230
Dallas ISD	18,314
Baylor Health Care System	17,097
AT&T Inc.	15,800
Lockheed Martin	14,126
JPMorgan Chase	13,500
UT Southwestern Medical Center at Dallas	13,122
City of Dallas	12,836
<i>Source: Dallas Business Journal 2013 Book of Lists</i>	

The largest North Texas public companies based on revenue include Exxon Mobil Corp., AT&T Inc., AMR Corp., Fluor Corp., Kimberly-Clark Corp., J.C. Penney Co. Inc., Southwest Airlines Co., Holly Frontier Corp., Texas Instruments Inc., and Dean Foods.

Below are the top ten public-sector employers located in North Texas:

Dallas/Fort Worth	
Top Ten Employers	of Local Employees
Dallas ISD	18,314
UT-Southwestern Medical Center at Dallas	13,122
City of Dallas	12,836
United States Postal Service	10,439
Fort Worth ISD	10,129
Parkland Health & Hospital System	8,134
Arlington ISD	7,907
Dallas County	7,411
Garland ISD	7,300
Dallas County Community College District	7,076
<i>Source: Dallas Business Journal 2013 Book of Lists</i>	

DALLAS/FORT WORTH METROPOLITAN ANALYSIS

DALLAS/FORT WORTH INVESTMENT CRITERIA

According to the Real Estate Research Center's 3rd Quarter 2013 Real Estate Report, investment criteria are as follows:

DALLAS/FT. WORTH

3RD QUARTER 2013

Dallas/Ft. Worth Investment Criteria First-Tier ¹ Investment Properties													
	Pre-Tax Yield (%)			Going-In Cap Rate (%)			Terminal Cap Rate (%)			Anticipated 1-Year Growth Rates			
	RERC Estimate	South Region	U.S.	RERC Estimate	South Region	U.S.	RERC Estimate	South Region	U.S.	National Value	South Value	National Rent	South Rent
Offc - CBD	8.7	9.3	9.0	7.1	7.6	7.3	7.9	8.4	8.0	2.1	1.6	1.9	1.4
Offc - Suburban	9.2	9.5	9.4	7.6	7.8	7.7	8.2	8.5	8.4	1.9	2.0	1.5	1.6
Ind - Warehouse	8.8	9.4	9.1	7.2	7.8	7.6	7.8	8.4	8.2	2.6	2.6	2.1	2.0
Ind - R&D	9.4	9.8	9.6	7.7	8.1	7.9	8.4	8.8	8.5	1.9	2.1	1.7	1.8
Ind - Flex	9.5	9.8	9.6	7.9	8.2	7.9	8.5	8.9	8.6	2.0	1.8	1.7	1.5
Ret - Reg Mall	8.5	9.1	9.1	7.0	7.5	7.5	7.7	8.2	8.1	1.3	1.3	1.3	1.2
Ret - Pwr Center	8.9	9.1	9.2	7.5	7.6	7.5	8.1	8.2	8.2	1.7	1.9	1.5	1.5
Ret - Neigh/ Comm.	9.0	9.3	9.3	7.5	7.8	7.7	8.1	8.3	8.4	2.1	2.5	1.9	2.1
Apartment	7.9	8.3	8.1	5.9	6.5	6.3	6.6	7.2	7.0	3.5	3.6	3.0	3.4
Hotel	10.1	10.3	10.2	8.2	8.4	8.5	9.0	9.2	9.2	2.6	3.1	2.2	2.7
Average	9.0	9.4	9.3	7.4	7.7	7.6	8.0	8.4	8.3	2.2	2.2	1.9	1.9

¹ First-tier investment properties are defined as new or newer quality construction in prime to good locations.
Source: RERC Investment Survey.

DALLAS/FORT WORTH METROPOLITAN ANALYSIS

Office Market

According to the *CB Richard Ellis 3rd Quarter 2013 D/FW Marketview*, the Dallas/Fort Worth office market is experiencing a steady decline in vacancy rates. Overall, vacancy rates have been declining, with lease rates slightly decreasing in the most recent quarters. With the uncertainty in the global economy, investors have become lease aggressive in the office market, with the quantity of proposed office projects declining. Medical offices continue as the strongest sector within the office inventory.

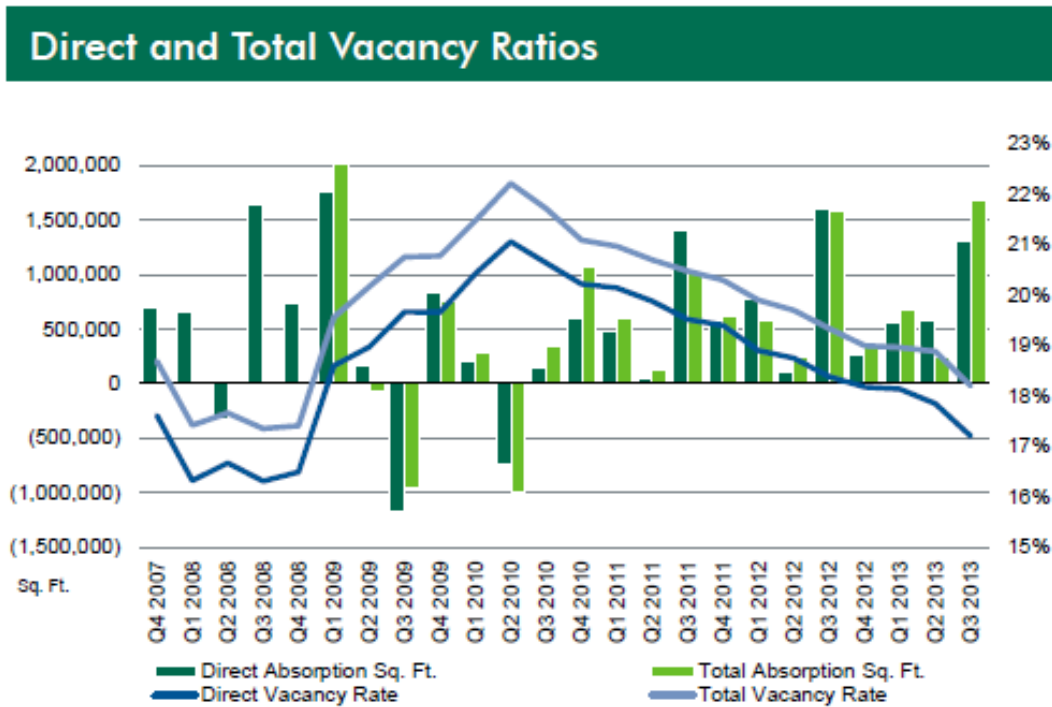

Source: CBRE Research, Q3 2013.

DALLAS/FORT WORTH METROPOLITAN ANALYSIS

Industrial Market

According to *CB Richard Ellis*, the industrial market showed signs of continued recovery into 2013. During the past three years, absorption has decreased and then bottomed out; however, for the sixth consecutive quarter, net absorption in the Dallas/Fort Worth industrial market has increased and vacancy rates have dropped. This indicates a growth in demand for space that will be necessary to move the market back to its pre-recession health. As tenants continue to read about the sluggish economy, they expect lower rent as a result. Supply will be increasing slightly, as construction has picked up and two speculative industrial developments have been announced.

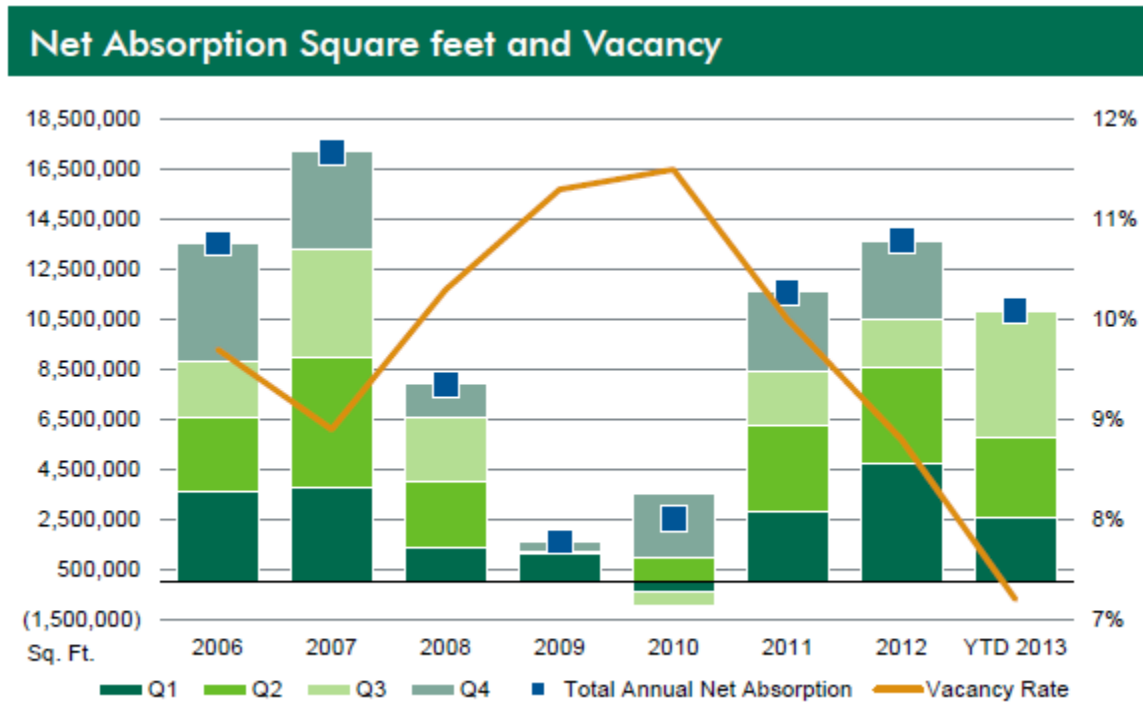

Source: CBRE Research, Q3 2013.

DALLAS/FORT WORTH METROPOLITAN ANALYSIS

Hospitality

The Dallas/Fort Worth Metropolitan Area remains strong in terms of the hospitality industry. The overall state of Texas market showed a 7% increase in revenue growth in the third quarter of 2013, largely driven by a 9.5% increase in the oil and gas exploration and production regions. However, Dallas/Fort Worth benefitted from a solid 5% gain in room revenue. With current broader market occupancy currently at 62.6%, the third quarter saw a 3.4% increase in occupancy from the previous period, and a 1.3% increase from the same period one year ago.

Sales Volume

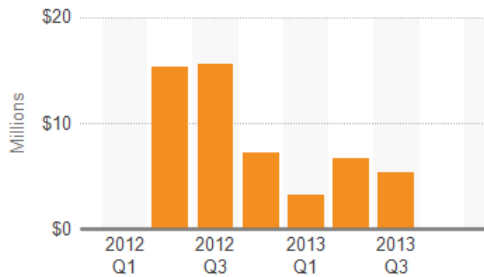

Average Sales Price Per SF

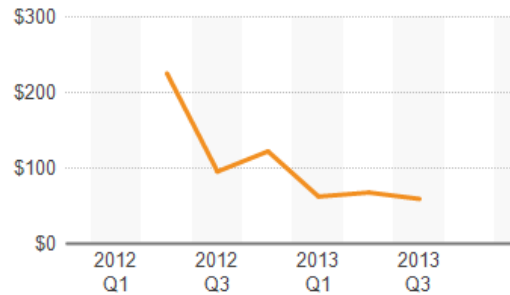

Sales volume as well as average sales price per square foot has declined in 2013 in comparison to 2012. This marks not only a decrease in properties offered for sale, but a recent shift away from upscale and full service properties. As displayed in the chart below, the midscale, limited service market remains consistent.

Sales Vol by Star Rating



Source: CoStar

DALLAS/FORT WORTH METROPOLITAN ANALYSIS

Retail

The Dallas/Fort Worth retail market continues to improve as occupancy and demand increases and rental rates remain level. Retail net absorption has been positive since 3rd quarter 2009 and is anticipated to continue. Of the total retail market inventory, neighborhood centers dominated the distribution with 32% of the market and strip centers at 24% of the inventory.

The Dallas/Fort Worth retail market is comprised of 84.7 million square feet. Relative to the other markets in the US, Dallas/Fort Worth is the 2nd largest by inventory size. Currently, Dallas/Ft. Worth has 13 square feet of neighborhood & community retail space per capita compared to the U.S. inventory level of 12.9 square feet per capita. The current Dallas/Fort Worth retail vacancy rate of 8.4% ranks 76th overall in the US. The vacancy rate has decreased by 500 basis points over the last year. Over the next five years, the vacancy rate is expected to decrease slightly.

Equilibrium 2019

Dallas/Fort Worth retail sales per capita are \$15,143. This is the 52nd largest sales per capita among US markets. Retail sales per capita are expected to grow by an annual rate of 3.1% over the next five years. This is projected to drive the Dallas/Fort Worth annual absorption of 1.2% as a percent of total inventory over the next five-years.

Currently, 1,163,127 square feet of neighborhood and community retail space is under construction, representing 1.4% of total inventory. Annual new supply is projected to represent 0.9% of total inventory. Over the last four years retail rents have fallen by 0.6% in Dallas/Fort Worth. The outlook in retail market fundamentals is expected to drive annual rental growth of 2.2% over the next five years. The 2012 estimated retail health ratio for Dallas/Fort Worth is 91.3 as compared to the average for all markets ratio of 99.7.

Retail Trends

In 2011, 64 retail transactions closed totaling \$1,095.9 million. Year-to-date 2012, 40 retail transactions have closed totaling \$1,015.2 million. This level of transaction activity compares to 2007 when 126 retail transactions closed for a total of \$2,260.0 million.

New developments of higher density, mixed-use centers offer unique opportunities to both businesses and residents of the Dallas–Fort Worth region. These developments are situated along the new light rail lines and include: Mockingbird Station, West Village, Victory Park, and Park Lane Place in Dallas, and Montgomery Plaza, Museum Place, and Sundance Square in Fort Worth. In addition, historic downtowns are being redeveloped into attractive regional destinations, including downtowns in Plano, McKinney, Denton, Carrollton, and Grapevine.

DFW ECONOMY

Market Center/Conventions

Located north of the Dallas Central Business District is the Dallas Market Center. This 150 acre, five building complex is the largest wholesale mart complex in the United States. Since its opening in the early 1950's, this center has grown to include a total of 5.1 million square feet consisting of the International Floral and Gift Center, Market Hall, Trade Mart, and the World Trade Center.

DALLAS/FORT WORTH METROPOLITAN ANALYSIS

The Dallas Market Center annually conducts more than fifty major markets for more than 200,000 professional buyers. The World Trade Center offers many services vital for international commerce, including consular offices, and trade commissions, foreign buying offices, translation and customs brokers.

The Dallas Convention Center (DCC) underwent a \$100 million expansion, completed in 2002. The Convention Center now features the world's largest singular column-free exhibit hall in the world, at 203,000 square feet and comprises one million square feet of exhibit space, ballrooms, meeting rooms, and is the only convention centre in the nation to have an art museum on the premises. The latest addition to the Dallas Convention Center is large enough to hold The Ballpark at Arlington (home to the Texas Rangers), and still have enough room so that the longest home run hit out of the ballpark would still be in the Convention Center. The DCC hosts 3,600 conventions annually and is one of the leading conventions sites in the US bringing more than \$4.2 billion to the Dallas economy.

Dallas/Fort Worth International Airport

The Dallas/Fort Worth International Airport, which opened January 1974, has had an enormous impact on the economy of the DFW metroplex. Located roughly sixteen miles northwest of the Dallas CBD and employing approximately 305,000 people, the 18,000-acre space is the second largest airport facility in the nation.

The airport has 5 terminals, 7 runways, 155 gates, and 191 destinations. D/FW Airport includes 12 instrument landing approaches and 3 control towers giving it the capacity of the three New York airports combined. D/FW is the only airport where four planes can land simultaneously. Twenty passenger airlines operate out of D/FW, of which eleven are commuter airlines, and nine are foreign flag airlines.

D/FW International Airport ranks eighth in the world, serving 57,806,918 passengers in 2011, 5,509,372 of which were international travelers. DFW also ranks fourth in the world in terms of operations with 646,803 takeoff/departures in 2011. Approximately 158,375 passengers travel daily through D/FW Airport. In 2011, 58% of the passenger makeup consisted of connecting flights while 42% was local.

American Airlines makes D/FW its home base with a high amount of total passengers on a monthly basis. D/FW Airport is also home to an impressive global distribution center with several cargo carriers, 2.6 million square feet of cargo facilities and a foreign trade zone with direct highway access. Covering more than 250 acres, this area is developing into a full service free trade zone. D/FW generates an estimated \$16.6 billion annually to the metroplex economy.

DALLAS/FORT WORTH METROPOLITAN ANALYSIS

Alliance Airport

The Alliance Airport is the world's first industrial/ air cargo and corporate airport in the nation and is designed to serve the needs of business as opposed to passenger service. Alliance Airport is located 15 miles north of downtown Fort Worth, 12 miles northwest of the Dallas/Fort Worth International Airport, and 29 miles to the northwest of downtown Dallas. This project, created by Ross Perot Jr., the city of Fort Worth and the FAA, is a master-planned industrial and commercial facility, which houses more than 140 companies – including over 62 from the Fortune 500, Global 500 and Forbes' List of Top Private Companies. Alliance is the only Foreign Trade Zone in North Texas with combined air, rail and highway access. In conjunction with the airport, Circle T Ranch, a 2,500-acre master-planned community, and Heritage, a 2,300-acre residential community, are transforming northern Tarrant County into a modern urban environment. Alliance Town Center is becoming the center of activity for the growing North Fort Worth area. The center includes a 500 acre retail center, Heritage Marketplace, luxury apartments, hospitals and more.

Las Colinas

Located on major traffic routes between the Dallas/Fort Worth International Airport, downtown Dallas, and the dense residential area of North Dallas, Las Colinas has become one of the major mixed-use developments in the nation. This master planned community covers approximately 12,000 acres within the city of Irving. With 22.3 million square feet of office space, Las Colinas is currently home to more than 2,000 companies. Las Colinas features three private country clubs and four championship golf courses surrounded by residential communities. The Four Seasons Las Colinas Resort has hosted the PGAs Byron Nelson Championship since it opened in 1986. It also contains high-rise office towers, retail centers, apartment complexes, and leisure facilities.

DALLAS/FORT WORTH QUALITY OF LIFE

Education

Educational facilities offered by the city of Dallas and the surrounding areas have grown to keep pace with the increasing population. As of 2010, the DFW MSA consisted of almost 100 school districts and over 1,800 schools with a total enrollment of over 1.1 million. Teacher-pupil ratios ranged from 15 to 3:15. The Dallas and Fort Worth Independent School districts ranked 5th among the largest school districts in the nation.

Twenty, four-year colleges and universities, and five community college districts with a combined total 20 campuses are within one hundred miles of the DFW MSA. Several notable institutions of higher education are located within the MSA.

- | | |
|-----------------------------------|---|
| • Dallas Baptist University | • University of Dallas |
| • Texas Christian University | • University of North Texas |
| • Texas Wesleyan University | • Texas Woman's University |
| • Baylor College of Dentistry | • University of Texas at Dallas |
| • Southern Methodist University | • University of Texas at Arlington |
| • Texas A&M University - Commerce | • University of Texas Southwestern Medical Center |

DALLAS/FORT WORTH METROPOLITAN ANALYSIS

Along with these colleges and universities are 75 technical and vocational programs in the Dallas/Fort Worth area. More than 280,000 full- and part-time students attend public and private four year colleges, universities, professional schools, community colleges or senior and graduate level institutions located in this region.

Recreation

Dallas and Fort Worth both offer a wide range of recreational and cultural amenities. Located within 100 miles of DFW are 406 area parks encompassing almost 23,000 acres and more than 60 lakes and reservoirs covering approximately 550,000 acres. DFW has more than 175 museums and galleries, 50 pro and community theatres and dozens of local symphony and chamber orchestras, ballet groups and opera associations. The Dallas Arts District, a sixty-acre section of the Dallas Central Business District, is taking shape into what is expected to become a major focal point in the Dallas arts community. Anchored by the Dallas Museum of Art, the Meyerson Symphony Center, and Nasher Sculptor Garden, the Dallas Arts District is the largest urban arts district in the country.

The Fort Worth Cultural District is home to several museums that are applauded for their architecture and the quality of their collections. Such museums include the Amon Carter Museum of American Art, Kimbell Art Museum, Modern Art Museum of Fort Worth, National Cowgirl Museum and Hall of Fame, Cattle Raisers Museum, and the Fort Worth Museum of Science and History.

Downtown Fort Worth encompasses Sundance Square in thirty five historic blocks where people live, work, stay, and play. Sundance Square is filled with great places to eat, shops and galleries, night clubs, live music and theater, Bass Performance Hall, and more.

The Fort Worth Stockyards is a nationally recognized historic district and is a major tourist attraction in the area. Stockyards Station is the only location that holds a daily longhorn cattle drive, the Fort Worth Herd. Cowboys drive the herd down East Exchange Avenue twice daily. The Stockyards is also home to the world's first indoor rodeo and opens the doors Friday and Saturday nights. Billy Bob's Texas, once a barn for prize cattle during the stock shows, is now 100,000 square feet where you can enjoy real bull riding, games, and performances by some of the biggest country music artists.

Dallas/Fort Worth is host to a wide range of sporting events throughout the year: home to the Dallas Cowboys, Texas Rangers, Dallas Mavericks, Dallas Stars, and FC Dallas Soccer. The area is also host to the Cotton Bowl (Arlington), Byron Nelson Golf Tournament (Irving), Colonial Golf Tournament (Fort Worth), and the Mesquite Rodeo (Mesquite).

Texas Motor Speedway, a development of Bruton Smith, city of Fort Worth and Denton County, opened in 1997. This facility, located at State Highway 114 and Interstate 35W, has a capacity of 200,000 persons. TMS draws huge crowds and lends to accelerated development to the area north of Alliance Airport. Major events to TMS are the NASCAR Nextel Cup, Samsung/Radio Shack 500, Dickies 500, NASCAR Busch Grand National Series, O'Reilly 300, O'Reilly Challenge, IRL, and the Bombardier Learjet 500.

DALLAS/FORT WORTH METROPOLITAN ANALYSIS

Lone Star Park, a class I horse racing facility, opened in Grand Prairie in 1997. The facility is located on Belt Line Road just to the north of Interstate 30. Lone Star Park covers 315 acres, includes a 36,000 square foot pavilion for simulcasting, and a seven story, 280,000 square foot grandstand with a capacity of roughly 8,000 people. The track has a one mile dirt oval and a 7 furlong turf track, and has accommodations for 1,600 horses across 32 barns. In 2004, it was the site of the Breeder's Cup, becoming the ninth race track to ever host a Breeders' Cup. At only seven years old, Lone Star Park is the youngest track to host the event.

Health Care

The city of Dallas excels in offering health care and medical related research facilities to the Southwest. Baylor Health Care Systems has been named 18th among the nation's Top 100 integrated health care networks by SDI, a leading health care market insight and analytics firm and the nation's premier rating system for IHN's. The Southwest Medical School of the University of Texas was ranked 17th among research medical schools and 23rd among primary care medical schools in the nation. Also, located in the Dallas area is the Wadley Institute of Molecular Medicine blood disease and cancer research facilities, and the headquarters for the American Heart Association, National Association for Retarded Children, and the American Association for Respiratory Therapy. Baylor college of Medicine is ranked 12th in medical research and 13th in primary care. Parkland Memorial Hospital ranks in the top 50 in five different medical fields.

Medical facilities in Fort Worth include: Baylor Health System, Cook's Children Health Care System, University of North Texas Health Science Center at Fort Worth, JPS Hospital, Plaza Medical Center of Fort Worth, The Center for Cancer and Blood Disorders, and Texas Health Harris Methodist Hospital Fort Worth.

Infrastructure

Water and wastewater needs are supplied by Dallas Water Utilities, North Texas Municipal Water District, Trinity River Authority, and Tarrant Regional Water District.

DALLAS/FORT WORTH METROPOLITAN ANALYSIS

CONCLUSIONS

The foregoing city data and local area economic base activity are presented to establish growth and income patterns, which materially affect real estate development, real estate sales volume and value. The Dallas/Fort Worth area, based upon past performances and reasonable forecasts, should continue an upward growth trend, both in population and employment, particularly in the suburban cities.

As population in the suburban communities continues to increase, and as traffic in and around the Central Core becomes more congested, both residents and local firms are beginning to look toward new, outlying employment centers. This is especially seen in North Dallas along the LBJ Freeway/Dallas Parkway Corridors as well as master planned areas such as Las Colinas and Legacy Business Park.

For most sectors of the North Texas metropolitan market, appreciation continued in recent years until 2007. Development trends from 2007 through 2009 were downward and sales volumes slowed dramatically. A slow recovery is underway, and while economic forecasts are varied, modest improvement seems to be a consensus. Overall, the Texas economy is proving more resilient and less over-built as compared to Florida, Arizona, Nevada, and California.

REGIONAL MAP

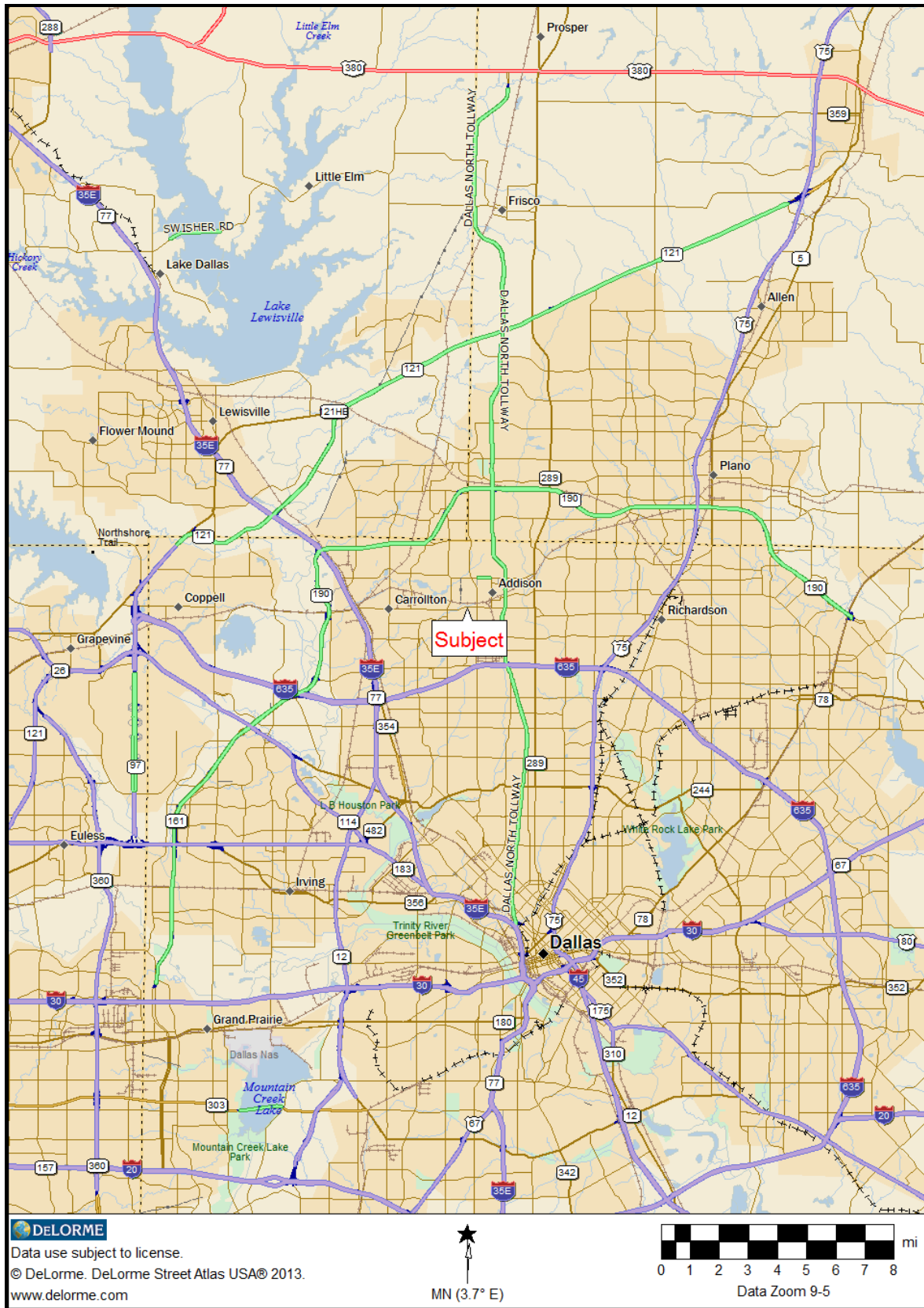

TOWN OF ADDISON ANALYSIS

The town of Addison, Texas is located 13 miles north of downtown Dallas, 16 miles northeast of DFW airport, and 11 miles north of Love Field airport. The town is bordered by the city of Carrollton to the west, Farmers Branch to the southwest, and Dallas to the south, east, and north.

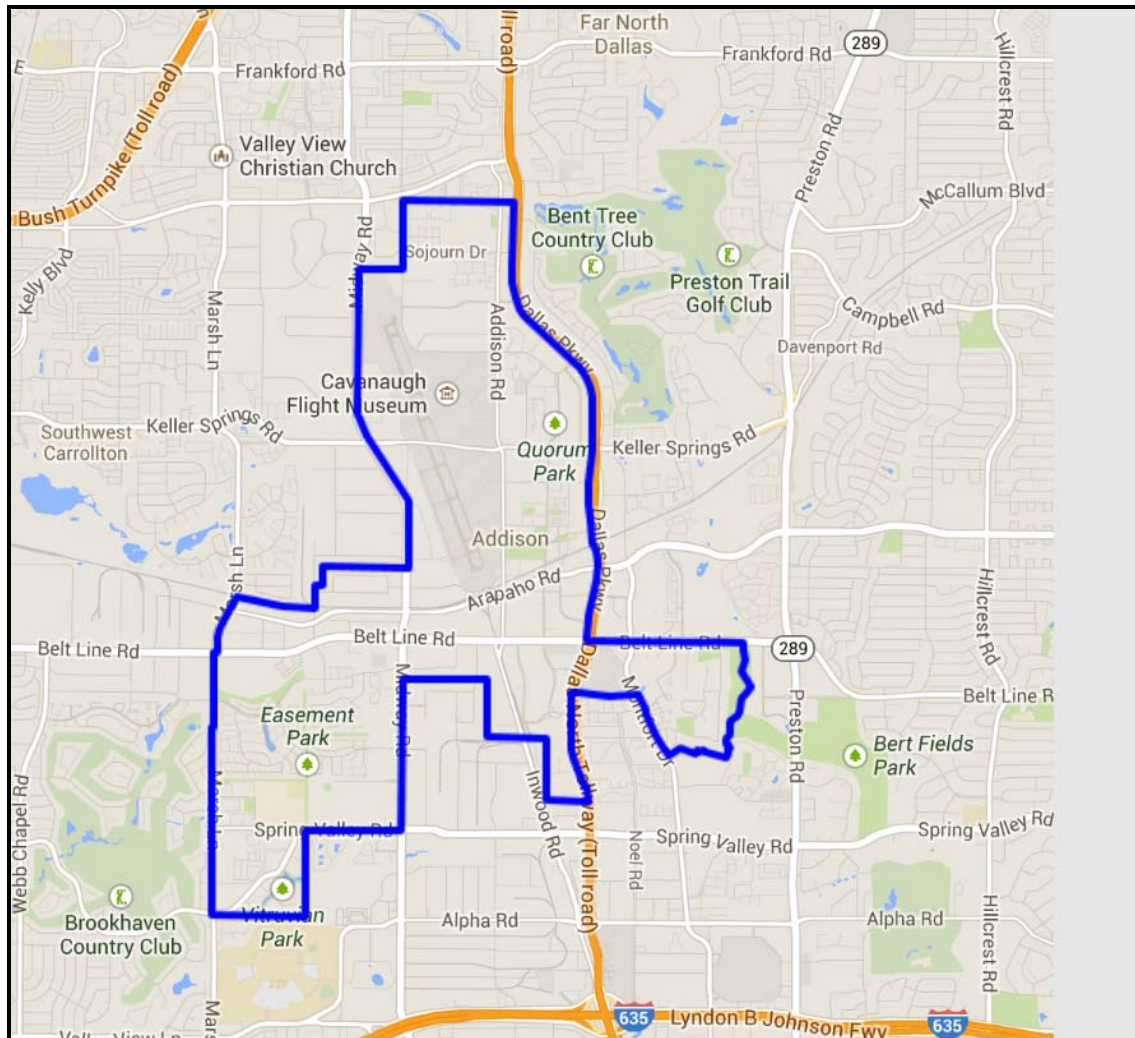

History

Incorporated on June 15, 1953, the Town of Addison is located in the area known at one time as Peters Colony, and settled circa 1846. The area was not known as Addison until 1902, named after Addison Robertson, who served as the community's second postmaster. With the adoption of a new charter, the community became the Town of Addison on April 3, 1982.

In 1975, an election to allow liquor by the drink served in town was a major attribute to the expansion of businesses and restaurants. All combined, Addison's restaurants and eating establishments can seat over 20,000 patrons at one time.

TOWN OF ADDISON ANALYSIS

During the late 1970's and early 1980's, Addison experienced explosive growth. The Town of Addison is included in the Dallas-Fort Worth-Arlington Metropolitan Statistical Area, and hence benefits from the economic and population growth trends of the Dallas-Plano- Irving Metropolitan Division.

Government

Governed by a council-manager form of government, the Town Council consists of a Mayor and six members who are elected by at-large elections. The Council enacts ordinances and determines policies, adopts the budget, and appoints the City Manager, who is the chief administrator.

Population, Transportation, and Commerce

Addison contains an estimated 15,179¹ people in a total of 8,419 households. During the day, the population of the town of Addison is estimated to increase to over 100,000 persons, attributable to the large number of employers in the area, as well as the more than 170 restaurants, 27 hotels with over 4,000 rooms, and a large number of retail stores and office buildings along the primary thoroughfares. Furthermore, Addison is corporate headquarters to Dresser, Mary Kay Cosmetics, Jani-King, Palm Harbor Homes, and MillionAire. Average per capita income is estimated to be \$47,727 and average household income is \$63,279, with an average unemployment rate of 6.1%.

The town of Addison covers 4.4 square miles of land, roughly one-half of which is improved with Addison Airport. The airport runway is 7,203 x 100 feet, and is equipped for ILS/DME and VOR/DME instrument approaches. The airport has an average of 366 aircraft operations each day, with 88% being considered general aviation, and 12% being air taxi, charter, or commercial flights. Aircraft based at the airport total 774, 49% of which are single engine, 24% of which are multiple engine, 24% of which are jet aircraft, and 3% of which are helicopters.

Primary thoroughfares providing north/south linkage include the Dallas Parkway/Dallas North Tollway, Addison Road, Inwood Road, Midway Road, and Marsh Lane. East/west linkage is provided by Keller Springs Road, Arapaho Road, Belt Line Road, and Spring Valley Road.

The area is one of the heaviest-developed business centers in northern Dallas, with dense concentrations of low-, mid-, and high-rise office buildings, industrial districts, and retail and restaurant uses. Though Addison is better than 90 percent built out, the town continues to prosper into the new millennium, and prime real estate and redevelopment opportunities remain at and near the Addison Airport and are anticipated for the future.

¹ United States Census, Addison, Texas Estimated 2012 Population

Employment and Unemployment

The Texas Workforce Commission does not specifically track the unemployment rate for Addison. Addison historical unemployment rates are estimated to be at or lower than Dallas County as a whole.

**Unemployment Rate
Dallas County**

(Source: Texas Workforce Commission)

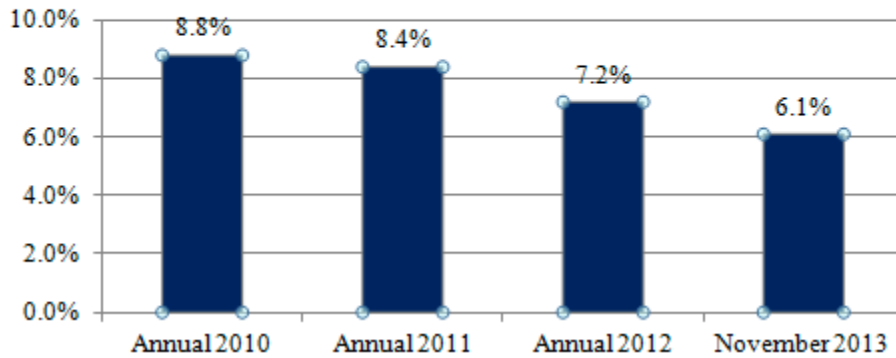

Retail Sales

In 2013, retail sales in the town of Addison totaled over \$575 million. Sales in 2005 totaled \$493 million, indicating 2% annual compounded growth. The number of retail businesses has increased from 427 in 2005 to 655 in 2013, indicating 5.5% annual compounded growth.

**Gross Retail Sales
(\$1,000s)**

Source: 2013 Texas Retail Survey (Eureka Group)

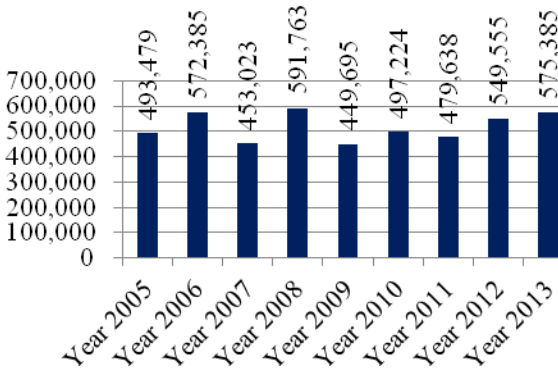

Retail Businesses

Source: 2013 Texas Retail Survey (Eureka Group)

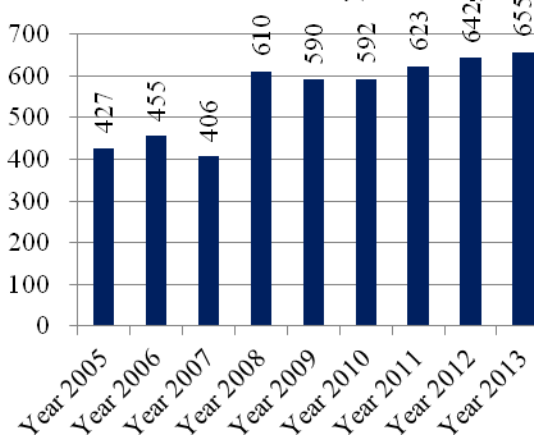

TOWN OF ADDISON ANALYSIS

Community Services

The town of Addison is served by the Dallas Independent School District and the Carrollton-Farmers Branch Independent School District. Fire and police protection are provided by the town of Addison. Electrical and telephone services are available through various providers, and natural gas is provided by Atmos Energy. Water and sewer services are also provided by the town of Addison.

Located between Addison Road, Addison Circle Drive, Quorum Drive, and Festival Way, Addison Circle Park is a 10-acre open space that serves as the special event site for the Town of Addison's community events such as: Taste of Addison, Kaboom Town, Oktoberfest, and others throughout the year.

Town of Addison Real Estate Market

The town of Addison is extensively developed with industrial, office, retail, and multifamily housing, with each property type considered in general terms below.

Industrial

A surveyed region, which includes Addison and neighboring areas, indicates a total of 101,377,615 square feet of industrial space, with a vacancy rate of 8.0% and average lease rates ranging from \$4.63 to \$7.51 per square foot on NNN terms.²

Office

In a manner similar to the industrial analysis, a surveyed region, which includes Addison and neighboring areas, indicates a total of 37,126,805 square feet of office space, with a vacancy rate of 14.5% and average lease rates of \$20.95 per square foot on full service terms.³

Retail

A surveyed region, including Addison and neighboring areas, indicates a total of 28,332,820 square feet of office space, with a vacancy rate of 8.7% and average lease rates of \$14.76 per square foot on NNN terms.⁴

Multi-Family Residential Apartments

In a survey of an area designated as "North Dallas/Addison", 106 properties are considered, with 28,727 units. The average rent per month is \$1.02 per square foot, with 92% occupancy.⁵

² CBRE, *MarketView*.

³ CBRE, *MarketView*.

⁴ CBRE, *MarketView*.

⁵ CBRE, *MarketView*.

TOWN OF ADDISON ANALYSIS

Single-Family and Multi-Family Owned Units

According to the 2010 United States Census for Addison, 73.4% of the 8,419 households are located in multifamily complexes (either condominium ownership or apartments). The remaining 2,239 units are detached single-family.⁶ Given the significant level of build-out in the town, new development is nominal. However, City Homes recently completed construction of 183 condominiums in the Addison Circle Urban Center. The homes range between 1,500 to more than 2,000 square feet.

Condominium list prices range from \$73,500 to \$280,000, or \$94.80 to \$141.03 per square foot. Detached single-family list prices range from \$182,500 to \$849,900, or \$93.63 to \$193.00 per square foot. Townhome list prices range from \$157,000 to \$382,000, or \$110.81 to \$189.14 per square foot.⁷

CONCLUSIONS

The Town of Addison is located along the prestigious Dallas Parkway corridor, and is a major employment center of northern Dallas. The locale is enhanced by residential areas in neighboring communities, and the area is expected to continue to be a major focal point in the commercial real estate market in the Dallas metropolitan area. Residential construction is evident in isolated areas throughout the town, but land availability will tend to retard this growth in the future.

The transportation network in the area is good and surrounding land uses are considered to be compatible and homogenous. The area is in proximity to employment centers and quality schools and services, and is considered a stable residential and commercial environment, with no noticeable nuisances or hazards. The majority of improvements are in the early to middle stages of economic life, and sufficient neighborhood services are accessible to service the community. The long-term prospects for the area and the subject property are positive.

⁶ United States Census, Addison, Texas Estimated 2012 Population.

⁷ North Texas Real Estate Information Systems (Local MLS), January 22, 2013.

Subject Vicinity

The subject is located in the Belt Line Road corridor in the town of Addison. The vicinity is west of Midway Road and east of Marsh Lane, and approximately one mile west of the Dallas North Tollway and 2.5 miles north of Interstate Highway 635 (LBJ Freeway).

The area consists of a variety of mostly commercial improvements, ranging from retail buildings and shopping centers, restaurants, office buildings, and others. The majority of improvements are adequately maintained and in average condition. The area is in a stable phase of its life cycle, with an estimated 95% of the land in use.

The traffic system is adequate to service the locale, with Belt Line Road as the primary east-west thoroughfare, and Midway Road and Marsh Lane the primary north-south routes. A number of connecting streets are interspersed throughout the area.

The following pages provide demographic data for the vicinity.

Neighborhood Demographics

The following Executive Summary provided by Site To Do Business provides demographic and income data for 1-mile, 3-mile, and 5-mile radii centered on the subject's location.



Site Map

4101 Belt Line Rd, Addison, Texas, 75001
Ring: 1, 3, 5 Miles

Prepared by Wendell Pyles
Latitude: 32.954498
Longitude: -96.84323

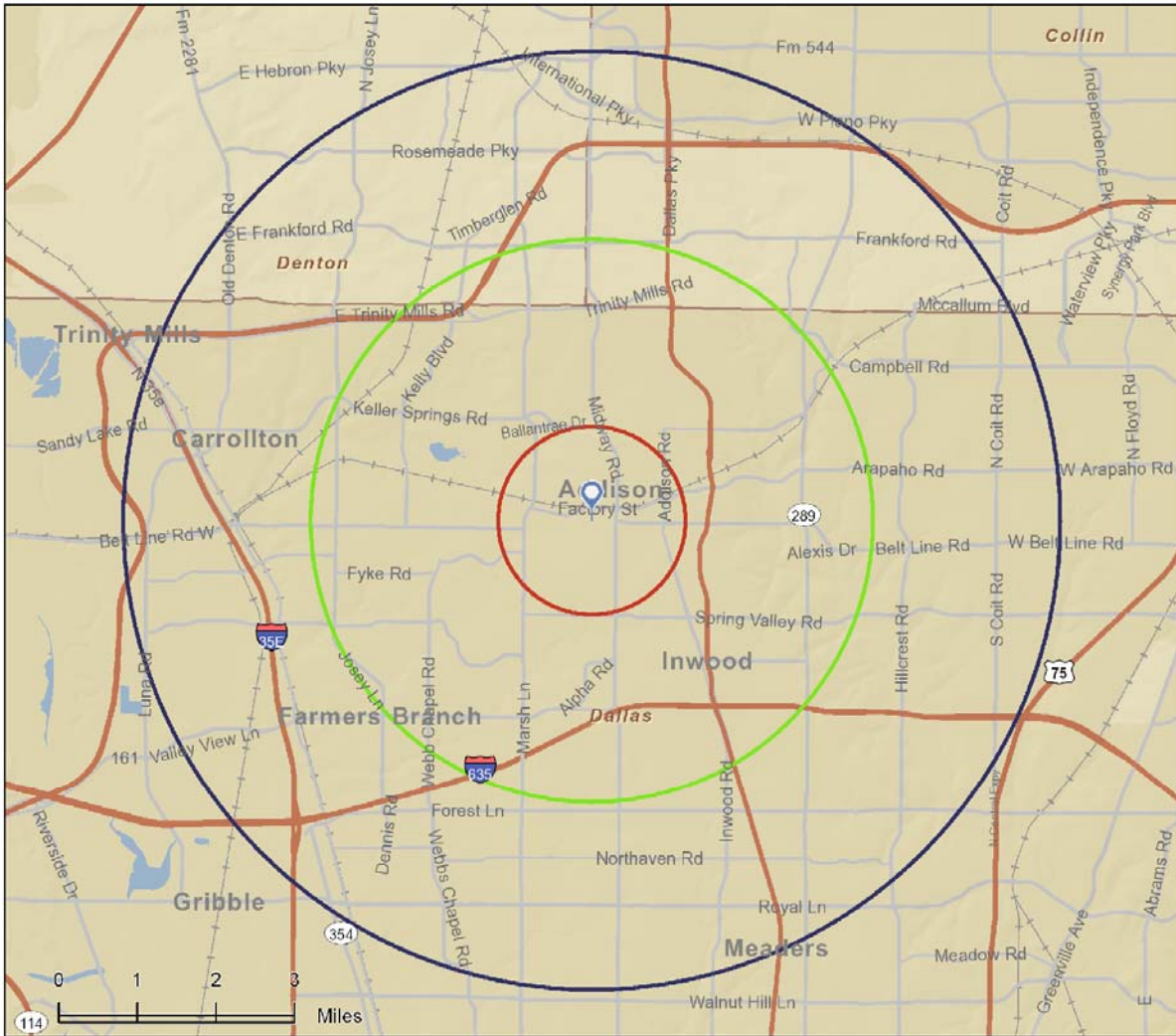



Executive Summary

3885 Belt Line Rd, Addison, Texas, 75001
Rings: 1, 3, 5 mile radii

Prepared by Wendell Pyles
Latitude: 32.95325823C
Longitude: -96.84967233

	1 mile	3 miles	5 miles
Population			
2000 Population	9,029	130,569	314,568
2010 Population	9,567	136,215	320,466
2013 Population	9,704	138,324	327,871
2018 Population	10,153	145,273	349,655
2000-2010 Annual Rate	0.58%	0.42%	0.19%
2010-2013 Annual Rate	0.44%	0.47%	0.71%
2013-2018 Annual Rate	0.91%	0.99%	1.29%
2013 Male Population	48.0%	49.4%	49.4%
2013 Female Population	52.0%	50.6%	50.6%
2013 Median Age	39.5	33.8	35.5

In the identified area, the current year population is 327,871. In 2010, the Census count in the area was 320,466. The rate of change since 2010 was 0.71% annually. The five-year projection for the population in the area is 349,655 representing a change of 1.29% annually from 2013 to 2018. Currently, the population is 49.4% male and 50.6% female.

Median Age

The median age in this area is 35.5, compared to U.S. median age of 37.3.

Race and Ethnicity

2013 White Alone	69.7%	63.0%	66.4%
2013 Black Alone	9.0%	11.2%	10.9%
2013 American Indian/Alaska Native Alone	1.2%	0.7%	0.6%
2013 Asian Alone	5.2%	5.8%	6.3%
2013 Pacific Islander Alone	0.0%	0.0%	0.0%
2013 Other Race	11.4%	16.0%	12.6%
2013 Two or More Races	3.4%	3.3%	3.1%
2013 Hispanic Origin (Any Race)	29.9%	41.0%	33.4%

Persons of Hispanic origin represent 33.4% of the population in the identified area compared to 17.4% of the U.S. population. Persons of Hispanic Origin may be of any race. The Diversity Index, which measures the probability that two people from the same area will be from different race/ethnic groups, is 74.6 in the identified area, compared to 62.1 for the U.S. as a whole.

Households

2000 Households	4,760	58,551	135,418
2010 Households	4,803	60,282	136,738
2013 Total Households	4,849	61,039	139,759
2018 Total Households	5,065	64,054	149,080
2000-2010 Annual Rate	0.09%	0.29%	0.10%
2010-2013 Annual Rate	0.30%	0.38%	0.67%
2013-2018 Annual Rate	0.88%	0.97%	1.30%
2013 Average Household Size	2.00	2.26	2.34

The household count in this area has changed from 136,738 in 2010 to 139,759 in the current year, a change of 0.67% annually. The five-year projection of households is 149,080, a change of 1.30% annually from the current year total. Average household size is currently 2.34, compared to 2.34 in the year 2010. The number of families in the current year is 79,297 in the specified area.

Conclusions

The immediate neighborhood is a diverse employment center in northern Dallas, and is enhanced by the surrounding residential areas. The transportation network in the area is good. Major roadways, regional freeways and toll roads provide good access for the area.

The area has enjoyed favorable economic opportunities. Characterized as a stable commercial and residential environment, the vicinity is a mixture of retail and restaurant buildings, office buildings, hotels, and office-warehouses and light industrial uses. The subject is congruent with neighborhood land uses.

The subject area is in a stable phase of development and in proximity to employment centers and quality schools and services with few improvements needing repairs and/or renovations. Consequently, some new construction, as well as renovation of older properties, is more likely to occur within the subject area in the near future. Additionally, there appears to be no detrimental influences upon the area that would inhibit the income-producing capabilities of the improved properties.

No noticeable nuisances or hazards are in the area and the majority of improvements are in the early to middle stages of economic life, and sufficient area services are accessible to service the community. The long-term prospects for the area and the subject property are positive.

LOCATION MAP

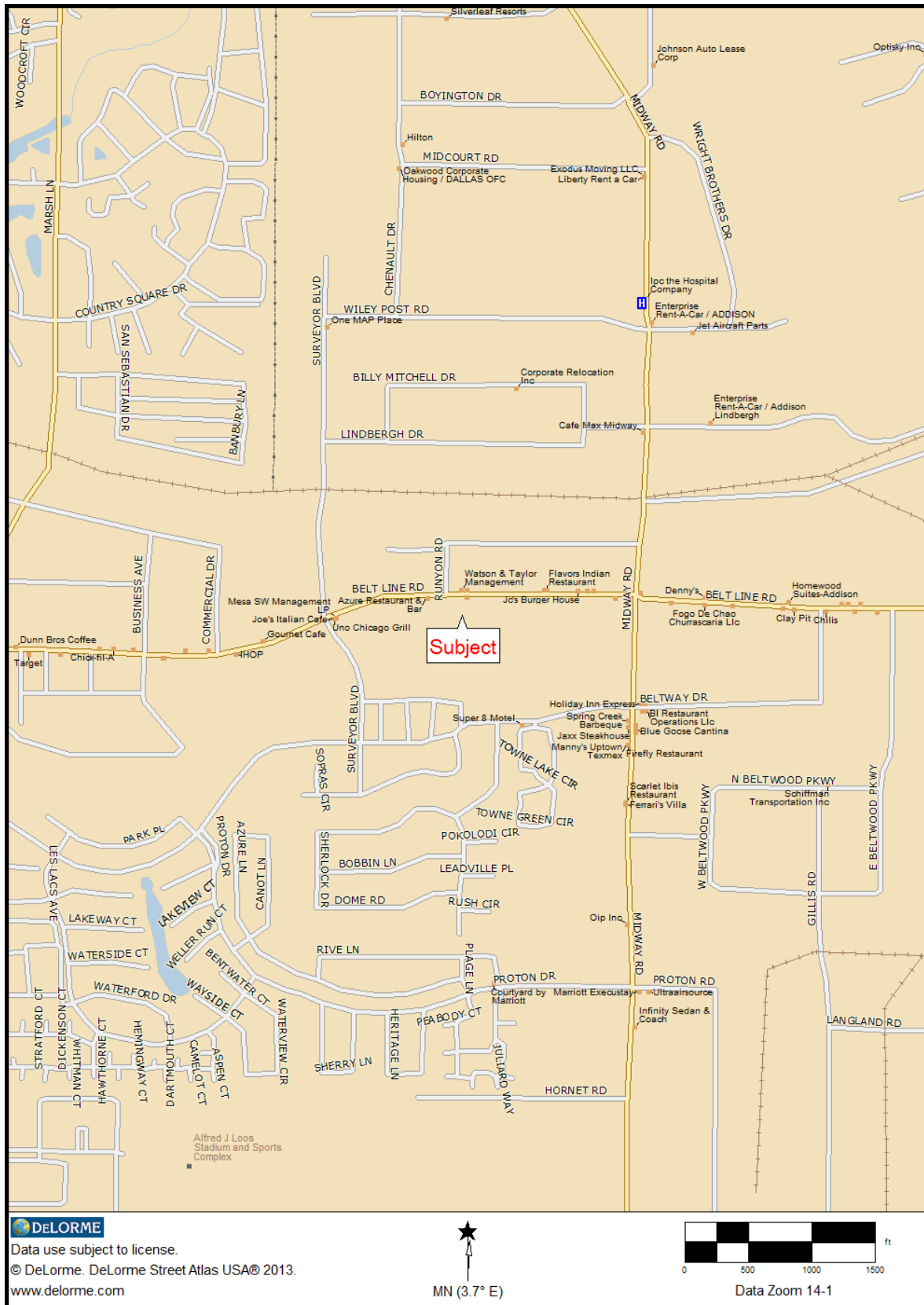

SUBJECT PROPERTY

The whole subject property is improved with a restaurant, located at 4080 Belt Line Road, Addison, Dallas County, Texas.

SITE DATA

Site/Dimensions/Frontage

Based on the information available, the whole property tract is mostly rectangularly shaped, and contains 66,184 square feet, or 1.5194 acres. The subject fronts the southern line of Belt Line Road for 157.57 linear feet, and the western line of Runyon Road for 459 feet. The subject is approximately 370 feet deep, from Belt Line Road.

Abutting Uses

The subject abuts Belt Line Road followed by commercial use along the north side, a restaurant along the east side, a hotel along the south side, and Runyon Road followed by a restaurant along the west side.

Linkages

The subject is accessible to arterial linkages and the distance to employment centers, retailers, restaurants, and schools is within reason in the town of Addison. In terms of travel time and actual distances by road, the subject property is within community standards.

Access

Overall, access for the neighborhood is rated as average. Access to and from the subject is average and via one curb cut along the eastern line of Runyon Road. Belt Line Road is a six-lane, divided roadway. Runyon Road is a two-lane, undivided roadway. Visibility and exposure of the subject are rated average.

Topography/Flood Zone

The topography of the tract is mostly level and at street grade, and is not problematic to development. According to FEMA flood hazard map 48113C0180J dated August 23, 2001, the subject is determined to be outside the 100-year floodplain, being within Zone X. Drainage of the site appears graded. No representation is made that the site will or will not flood. A hydrological study or survey is required for confirmation of flood-designated boundaries.

Environmental Conditions

To our knowledge, a Phase I Environmental Site Assessment has not been completed for the subject property as of the date of inspection. A current Phase I ESA is recommended. The subject is appraised predicated on the absence of detrimental environmental conditions. The conclusions of this appraisal report would be materially changed if detrimental environmental conditions affect the subject.

SUBJECT PROPERTY

Utilities/Community Services

Electricity, water, sewer, and phone services are available to the subject. Electric service and telecommunication services are available by various providers. Natural gas service is available from Atmos Energy. Water and wastewater is provided by the town of Addison. Police and fire protection are provided by the town of Addison. The property is located within the Dallas Independent School District.

Zoning

The site is zoned PD, Planned Development by the town of Addison. The PD, Planned Development district is intended to encourage better development in the town by allowing more flexibility in the planning and development of projects. The district is further designed to allow the city council greater control over development. The district allows a wide range of commercial uses. Restaurants are allowed in this zoning district. Ordinance 092-058 was passed in 1992 further specifying use of the property. The parking requirement for restaurants is one space per seventy square feet of building area. Reference an excerpt of the ordinance, following.

Soils

Soils in this area vary and can require specific engineering considerations. This condition is considered typical for the area, and no unusually unstable soil-bearing capacities are known.

Easements

A complete survey of the site is not available for analysis. A twenty-foot drainage easement is along the northern property line and a ten-foot by forty-foot sign easement benefiting the southern abutting Hilton Hotel is at the northwest property corner. Runyon Road appears to be an access easement, with responsibility of its maintenance belonging to the private property owners. This valuation assumes that utility and access easements typical of this property type are present and that no detrimental easement conditions exist. This should not be considered as a guaranty or warranty, however, that adverse easements do not exist. Were the property to have any easements detrimental to the subject, the opinion of value concluded herein may be invalid.

Deed Restrictions

To our knowledge, no deed restrictions affect or limit the use of the property; however, this should not be considered as a guaranty or warranty that no such restrictions exist. Deed restrictions are a legal matter: normally discoverable only by a title search by a title attorney. It is recommended that a title search be made if any questions regarding deed restrictions arise.

SUBJECT PROPERTY

Wetlands

No visual evidence was observed to indicate whether wetlands exist on the subject site. Wetlands, as defined by Section 404 of the Clean Water Act, are those areas that are inundated or saturated by surface or groundwater at a frequency and duration sufficient to support, and under normal circumstances do support, a prevalence of vegetation typically adapted for life in saturated soil conditions. Swamps, bogs, fens, marshes, and estuaries are subject to federal environmental law.

SUBJECT IMPROVEMENTS

Improvements

The land is improved with a restaurant and site improvements. According to field measurements, the building comprises 6,351 square feet of gross building area.

Orientation

The building is mostly rectangular in shape and oriented to Belt Line Road. The distance is approximately 34 feet from the building to the existing right of way along Belt Line Road and approximately 17 feet to Runyon Road. The proposed fee simple acquisition is approximately 6.7 feet from the northwest restaurant corner.

Age, Construction and Condition

According to tax records, the building was constructed in 1993. The building is Class D, of wood frame and brick veneer construction on a concrete slab foundation. Quality is rated as average, and the improvements appear to be in average condition.

Our opinion of the improvements' effective age is equal to the actual age, which is 21 years. According to Marshall & Swift Valuation Service, the typical economic life span for buildings of the same construction class and design as the subject is typically 35 years. Therefore, the subject is said to have a remaining economic life of 14 years (35 years less the effective age of 21 years).

No functional obsolescence is noted. No items of deferred maintenance are observable.

Site Improvements

Site improvements are comprised of concrete paved parking and drives, curbing and parking bumpers, lights standards, landscaping, a dumpster enclosure, a covered patio, and an irrigation system. Landscaping includes trees, bushes, flower beds, and grass. Overall, the improvements appear to be adequately maintained and in average condition. Quality is rated as average. No items of deferred maintenance are observable.

SUBJECT PROPERTY

Parking

The parking requirement is one space per 70 square feet of building area. The site has adequate parking and circulation to satisfy the zoning requirement.

Occupancy and Rentals

Azure occupies the property under a lease agreement for \$9,701 per month, or \$18.33 per square foot on a triple net expense basis. Property income and expense data are not available.

Functional Utility

Defined as the ability of a property or building to be useful and to perform the function for which it is intended according to current market tastes and standards. The subject is a restaurant. The improvements are functionally adequate given the architectural style, design and layout, traffic patterns, and the size and configuration of the improvements for this property type.

External Obsolescence

External obsolescence is considered to be the loss in value of the property resulting from an influence of negative forces not inherent with the property. It can be caused by the exertion of detrimental external forces upon the area or property itself. Specific examples are significant fluctuations in the local economy, noise from nearby expressways or airports, excessive taxes, supply and demand imbalances, special assessments or certain other governmental actions, the lack of financial liquidity in the marketplace, or the infiltration of unharmonious groups or land uses. This form of obsolescence is rarely, if ever, curable.

The subject area is over supplied with restaurant space. The Belt Line road corridor at the Dallas North Tollway through Addison and into Dallas is arguably one of the most concentrated restaurant areas in the metroplex. The high competition in the direct vicinity has caused a downward pressure on restaurant rents.

CONCLUSIONS

The subject is improved with a restaurant, with adequate frontage and access via one curb cut along the eastern line of Runyon Road. Condition of the improvements is average. The property appears to be a legal conforming use.

REAL ESTATE TAX ANALYSIS

The Texas legislature created a system of centralized appraisal districts for each Texas county so that all real estate within a given county is valued for tax purposes through a standard appraisal process. Property assessments are based on market value. Property valuations under the central appraisal district system became effective in 1982.

In Dallas County, the Dallas Central Appraisal District is responsible for ad valorem tax appraisals of all real estate within the county. Based on the ad valorem tax appraisal, various tax districts levy annual taxes on property located within their respective districts. Typical taxing jurisdictions include assessments from the county, city, and school districts in which the property is located. The total ad valorem tax burden is the sum of the assessments for the various taxing authorities.

The subject property is situated within the Town of Addison, and falls within the taxing jurisdictions of the town of Addison, Dallas County, Dallas County Community College, Parkland Hospital, and Dallas Independent School District. Pertinent 2013 tax rates for the subject are detailed below.

2013 TAX RATES (per \$100)	
Town of Addison	\$ 0.571800
Dallas County	\$ 1.282085
Dallas County Community College	\$ 0.253100
Parkland Hospital	\$ 0.124700
Dallas Independent School District	\$ 0.276000
Total	\$ 2.507685

The Dallas Central Appraisal District account for the subject assessment for 2013 is summarized as follows:

Account Number	Land	Improvements	Total
10002400010010000	\$ 661,840	\$ 13,160	\$ 675,000

Based on the preceding assessed value and pertinent tax rates, the subject's annual tax liability is calculated as follows:

Assessed Value	Tax Rate/\$100	Indicated Tax Liability
\$675,000	x \$2.507685	= \$ 16,927

The assessed value is \$675,000, or \$106.28 per square foot, and is below the concluded market value in this appraisal. This difference is typically due to the valuation methods of the appraisal district.

The land value is \$10.00 per square foot, and is below the concluded market value in this appraisal. This difference is typically due to the valuation methods of the appraisal district.

AERIAL PHOTOGRAPH

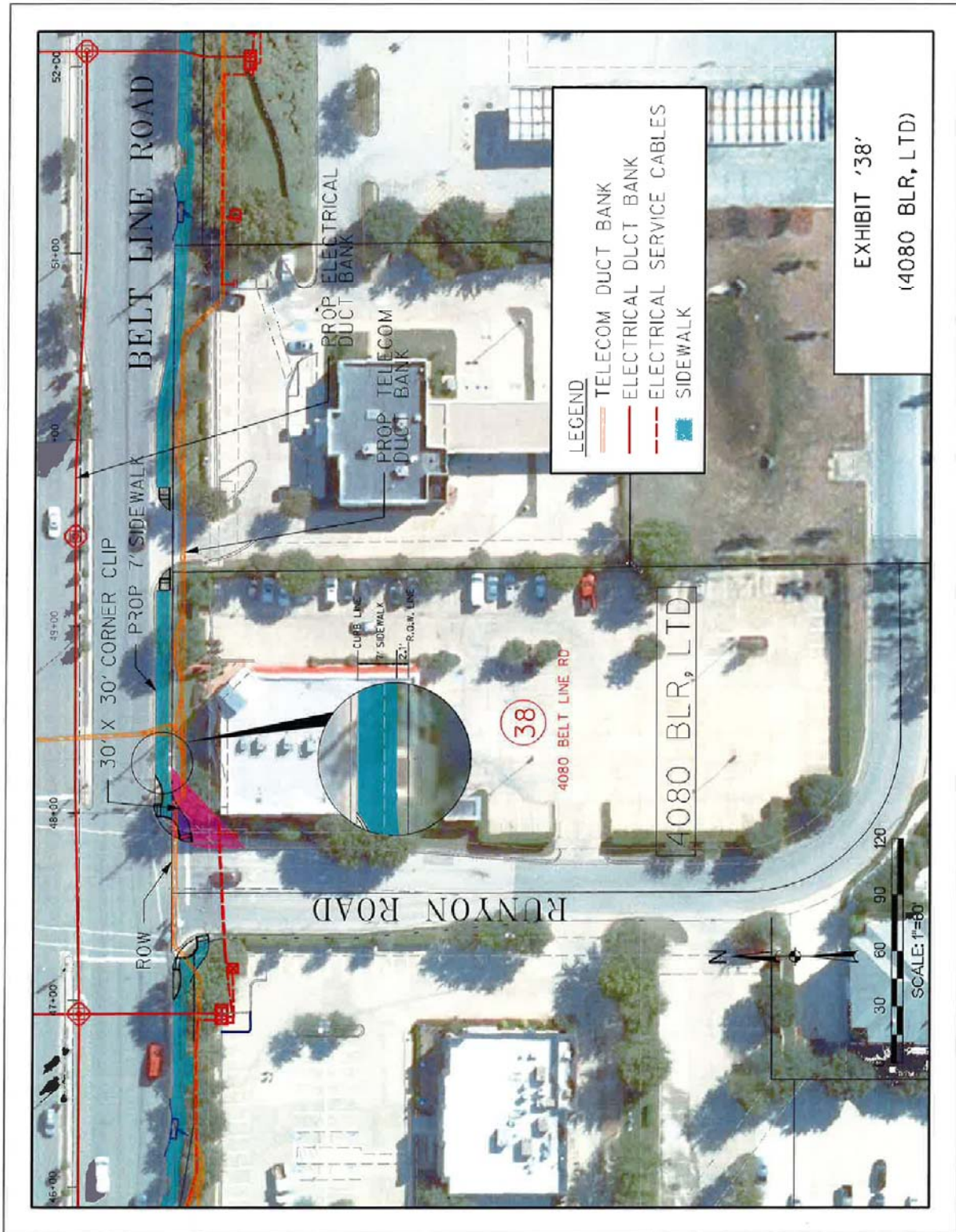

SUBJECT PHOTOGRAPHS

PHOTOGRAPHED JANUARY 15, 2014



Looking west at the restaurant building.



Looking north at the rear of the improvements.

SUBJECT PHOTOGRAPHS



Viewing interior.



Viewing kitchen area.

SUBJECT PHOTOGRAPHS



Looking east along Belt Line Road, subject at right.



Looking west along Belt Line Road, subject at left.

SUBJECT PHOTOGRAPHS



Looking southwest along the proposed fee simple acquisition.



Looking northeast along the proposed fee simple acquisition.

SUBJECT PHOTOGRAPHS



Looking north along Runyon Road and along the proposed fee simple acquisition.



Looking south along Runyon Road, subject at left.

WHOLE PROPERTY SKETCH

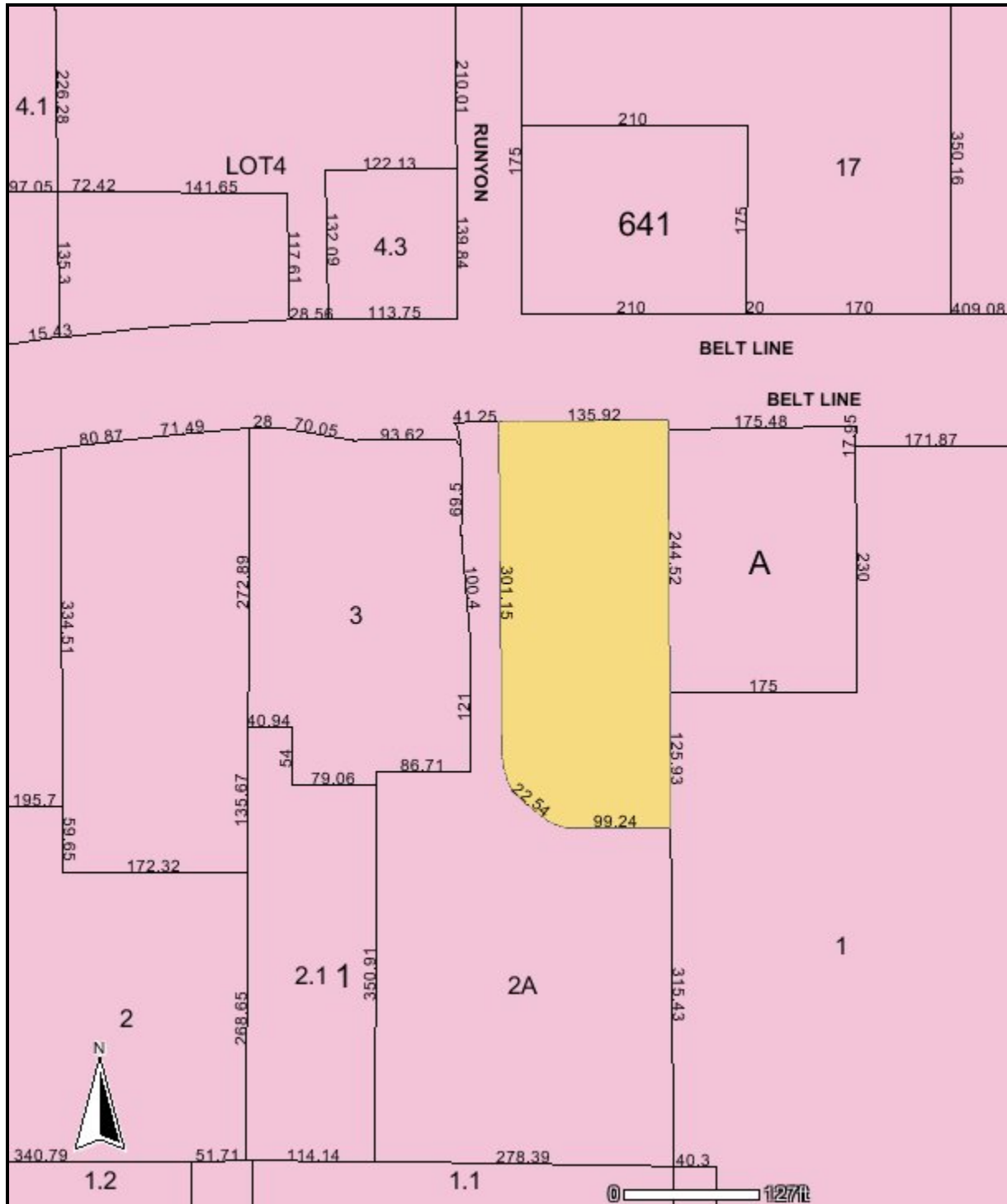

BUILDING SKETCH

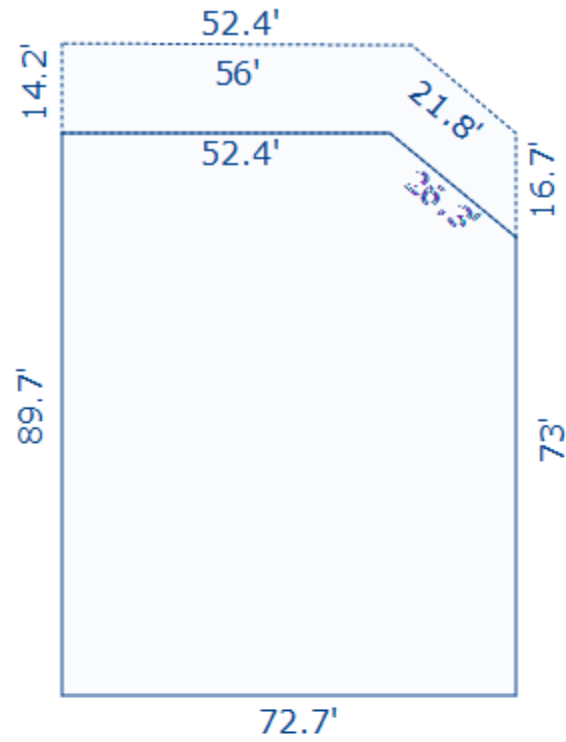

Calculated Areas Summary X

Code	Area Name	Net Size	Net Total
GLA1	First Floor	6351.7	6351.7
P/P	Porch	1076.0	1076.0

NetAreas (Rounded) : Living = 6352

ZONING MAP

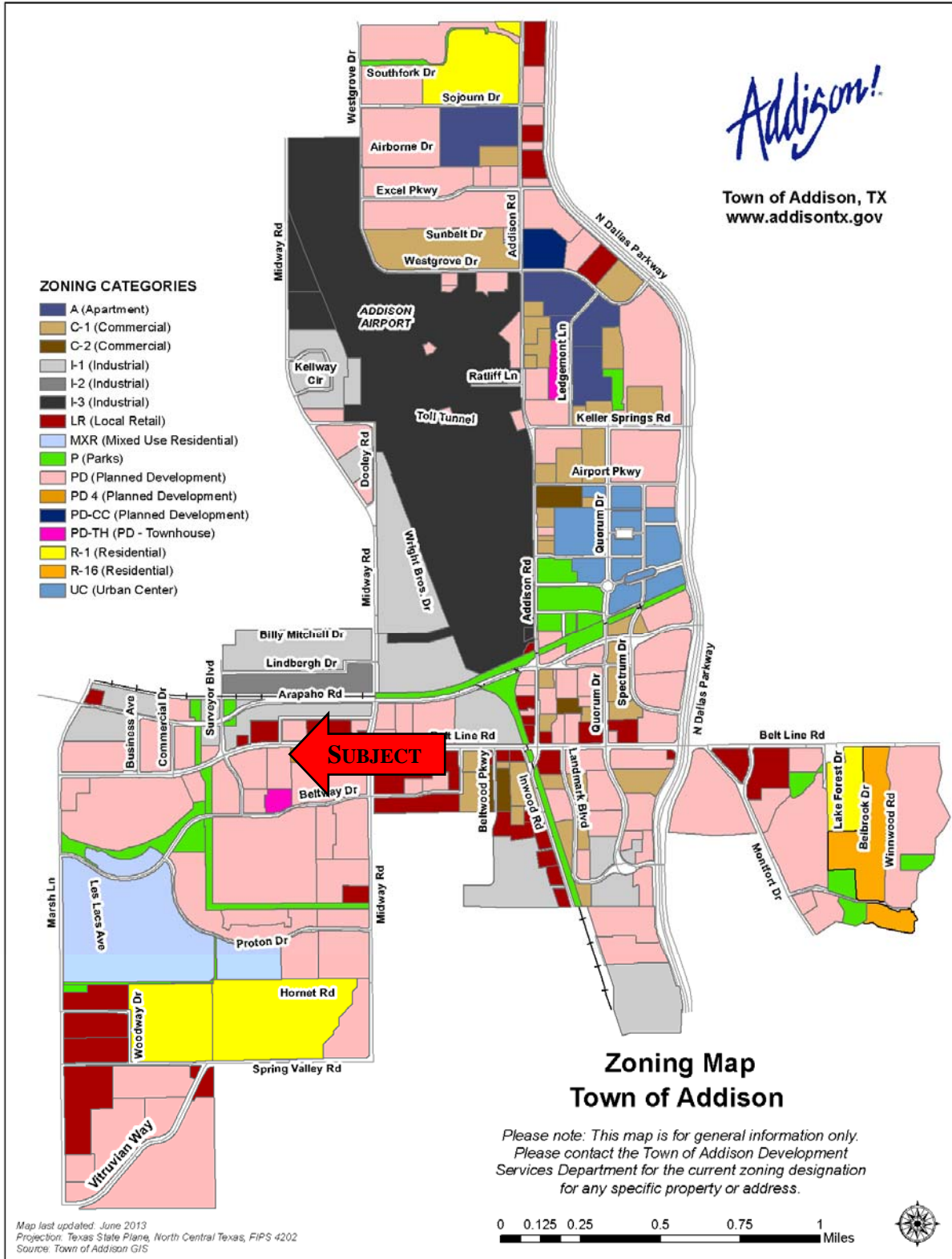

ZONING EXCERPT

ORDINANCE NO. 092-058

AN ORDINANCE OF THE TOWN OF ADDISON, TEXAS, AMENDING THE COMPREHENSIVE ZONING ORDINANCE OF THE TOWN OF ADDISON, TEXAS, BY AMENDING ORDINANCE 460, SECTION 3, PARAGRAPHS (d) AND (f) TO PROVIDE FOR A CHANGE IN THE REQUIRED PARKING RATIOS FOR RESTAURANTS, AND A CHANGE IN THE REQUIRED EXTERIOR FINISH MATERIALS, ON APPLICATION FROM THE TOWN OF ADDISON, PROVIDING FOR A PENALTY CLAUSE; PROVIDING FOR A SEVERABILITY CLAUSE; AND PROVIDING FOR A REPEAL CLAUSE.

WHEREAS, application was made to amend the Comprehensive Zoning Ordinance of the Town of Addison, Texas, by making application for the same with the Planning and Zoning Commission of the Town of Addison, Texas, as required by State Statutes and the zoning ordinance of the Town of Addison, Texas, and all the legal requirements, conditions and prerequisites having been complied with, the case having come before the City Council of Addison, Texas, after all legal notices, requirements, conditions and prerequisites having been complied with; and

WHEREAS, the City Council of the Town of Addison, Texas, does find that there is a public necessity for the zoning change, that the public demands it, that the public interest clearly requires the amendment, and it is in the best interest of the public at large, the citizens of the Town of Addison, Texas, and helps promote the general welfare and safety of this community, now, therefore,

BE IT ORDAINED BY THE CITY COUNCIL OF THE TOWN OF ADDISON, TEXAS:

SECTION 1. That the Comprehensive Zoning Ordinance of the Town of Addison, Texas, is hereby amended by amending Ordinance 460, Section 3, Paragraph (d) to read as follows:

OFFICE OF THE CITY SECRETARY

ORDINANCE NO. 092-058

ZONING EXCERPT

- (d) Off-street parking spaces shall be provided for the appropriate building use classification according to the following ratios:
- A. General retail: (1/200 s.f.) One space per each two hundred square feet of floor area.
 - B. Furniture store: (1/1000 s.f.) One space per each one thousand square feet of floor area.
 - C. Medical or Dental offices: (1-200 s.f.) One space per each two hundred square feet of floor area.
 - D. Banks or Savings and Loans: (1/300 s.f.) One space per each three hundred square feet of floor area.
 - E. Office: (1/300 s.f.) One space per each three hundred square feet of floor area. An office complex of 50,000 square feet or more: (1/300 s.f.) square feet of gross leasable area.
 - F. Motion Picture Theater: (1/4 seats) One space per each four seats based on maximum occupancy load.
 - G.
 - 1. Parking Regulations/Free Standing Restaurants.
 - a. Restaurants: (1.70 s.f.) One space for seventy (70) square feet of floor area for all free standing buildings unless it is part of a shopping center or mixed use development.
 - 2. Parking Regulations/Mixed Use Developments.
 - a. If all buildings which are part of the development total less than 30,000 square feet in area, and the development has more than 40% of its floor area devoted to restaurant uses, the parking for the restaurant uses shall be provided at a ratio of one (1) space for every seventy (70) square feet of gross restaurant floor area.
 - b. Free standing restaurants which occur within the mixed-use developments shall be required to provide parking at the ratio of one (1) parking space for every one hundred (100) square feet of gross floor area if the property is deed restricted or if covenants exist which allow the restaurant the use of the entire on-site parking provided by the development. Such on-site parking must adjoin and/or be contiguous to the restaurant use. When there are no deed restrictions or covenants allowing restaurants

OFFICE OF THE CITY SECRETARY

ORDINANCE NO. 092-058

ZONING EXCERPT

the use of on-site parking, free standing restaurants in mixed-use developments shall be required to provide parking at the ratio of one (1) parking space for every seventy (70) square feet of gross floor area.

- H. Retail and service buildings shall provide and maintain off-street facilities for the loading and unloading of merchandise and goods, within the building or on the lot adjacent to a private alley or private service drive to facilitate the movement of traffic on the public streets. Such space shall consist of a minimum area ten (10) feet by twenty-five (25) feet for each twenty thousand (20,000) square feet of floor space or fraction thereof in excess of three thousand (3,000) square feet in the building or on the lot used for retail, storage or service purposes.

SECTION 2. That the Comprehensive Zoning Ordinance of the Town of Addison, Texas, is hereby further amended by amending Ordinance 460, Section 3, Paragraph (f) to read as follows:

- (f) At least eighty percent (80%) of the exterior walls of all structures shall be of masonry construction. Front and side walls shall be of brick or stone veneer construction.

SECTION 3. That all ordinances of the City in conflict with the provisions of this ordinance be, and the same are hereby repealed, and that Ordinance 086-012 shall be specifically repealed by this ordinance, and that all other ordinances of the City not in conflict with the provisions of this ordinance shall remain in full force and effect.

SECTION 4. That any person, firm, or corporation violating any of the provisions or terms of this ordinance shall be subject to the same penalty as provided for in the Comprehensive Zoning Ordinance of the city, as heretofore amended, and upon conviction shall be punished by a fine set in accordance with Chapter 1, General Provisions, Section 1.10, General penalty for violations of Code; continuing violations, of the Code of Ordinances for the Town of Addison.

OFFICE OF THE CITY SECRETARY

ORDINANCE NO. 092-058

FLOOD MAP

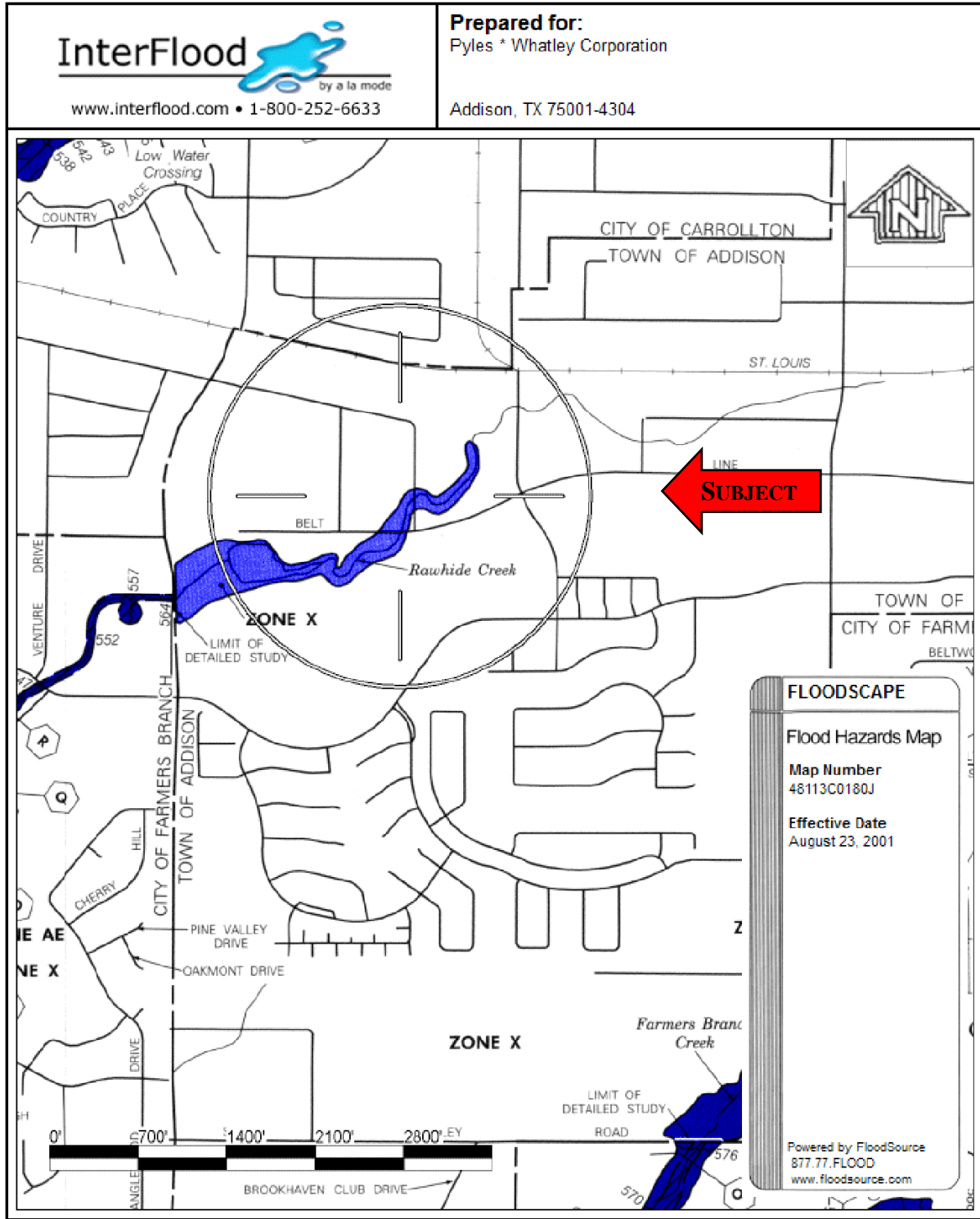

© 1999-2013 SourceProse and/or FloodSource Corporations. All rights reserved. Patents 6,831,326 and 6,878,815. Other patents pending. For Info: info@floodsource.com.

HIGHEST AND BEST USE

The *Highest and Best Use* analysis should consider the reasonably probable and legal use of vacant land or improved property considering legally permissible, physically possible, financially feasible, and maximally productive.

HIGHEST & BEST USE AS IF VACANT

The subject is a 1.5194-acre tract of land and is rectangularly shaped. The size and shape of the tract is supportive of a number of potential developments.

Possible Use: In arriving at an opinion of highest and best use for the subject, it is first necessary to determine if the physical characteristics of the site - such as soil conditions, topography, shape and frontage were favorable for development. Soil conditions vary throughout the area and sometimes require particular engineering. The subject fronts the southern line of Belt Line Road for 157.57 linear feet, and the western line of Runyon Road for 459 feet. According to the enclosed flood map 48113C0180J, the subject is determined to be outside the 100-year floodplain, being within Zone X. The site is of sufficient size, shape, and frontage to be economically adaptable to numerous uses. The size and shape of the site is adequate for commercial development.

Permissible Use: The site is zoned PD, Planned Development by the town of Addison. The PD, Planned Development district is intended to encourage better development in the town by allowing more flexibility in the planning and development of projects. The district is further designed to allow the city council greater control over development. The district allows a wide range of commercial uses.

Feasible Use: The surrounding properties and land uses are considered for compatibility in determination of feasible use. The subject abuts Belt Line Road followed by commercial use along the north side, a restaurant along the east side, a hotel along the south side, and Runyon Road followed by a restaurant along the west side. Based on the land usage pattern of the surrounding area, the layout, location and frontage/visibility of the site, the most feasible use is for commercial use.

Maximally Productive Highest & Best Use: As if vacant, the subject has frontage along Belt Line Road and Runyon Road (one curb-cut). Belt Line Road is a six-lane, divided roadway. Runyon Road is a two-lane, undivided roadway. For a commercial use, the location is average for appeal within the submarket. Access is rated as average and visibility of the subject is rated as average. Electricity, water, sewer, and phone services are available to the subject. Based on the foregoing and land use patterns, the highest and best use of the subject tract is for commercial use.

HIGHEST AND BEST USE

HIGHEST & BEST USE AS IMPROVED

Possible Use: The improvements were built in 1993, according to the Dallas County Appraisal District. The improvements are of average quality and in average condition. Overall, the improvements are adequately maintained and have no deferred maintenance. The intended use of the improvements is for restaurant use. The physical characteristics and accompanying amenities support the continued use as such.

Permissible Use: The site is zoned PD, Planned Development by the town of Addison. The PD, Planned Development district is intended to encourage better development in the town by allowing more flexibility in the planning and development of projects. The district is further designed to allow the city council greater control over development. Restaurants are allowed in this zoning district.

Feasible Use: The existing improvements have an effective age of approximately 21 years, based on the modified economic life concept. With proper maintenance, a property of this type typically has an economic life of 35 years. Remaining economic life of the improvements is estimated at 14 years, based on an economic life of 35 years and an effective age of 21 years, and no other use of the improvements could provide a greater return in the current market.

Maximally Productive Highest & Best Use: As improved, the property is a restaurant and is suitable for restaurant use. Therefore, the continued use as a restaurant represents the highest and best use of the land and improvements.

LAND VALUATION

The *sales comparison* method is the best method of developing an opinion of value of the subject. In this method, known sales of similar use land in the market area are compared to the subject to arrive at an indication of value. In arriving at value conclusions, the tracts are compared as to the rights conveyed, financing terms, sale conditions, market conditions, location, and physical characteristics. This approach is used to value land that is vacant or considered vacant for appraisal purposes.

The market was carefully researched for recent sales, listings, or other transactions, which would provide a valid basis for developing an opinion of the market value of the subject by comparison. After reviewing and analyzing the sales, the sales detailed on the following pages were extracted from this sample and utilized for the land valuation.

LAND SALES MAP

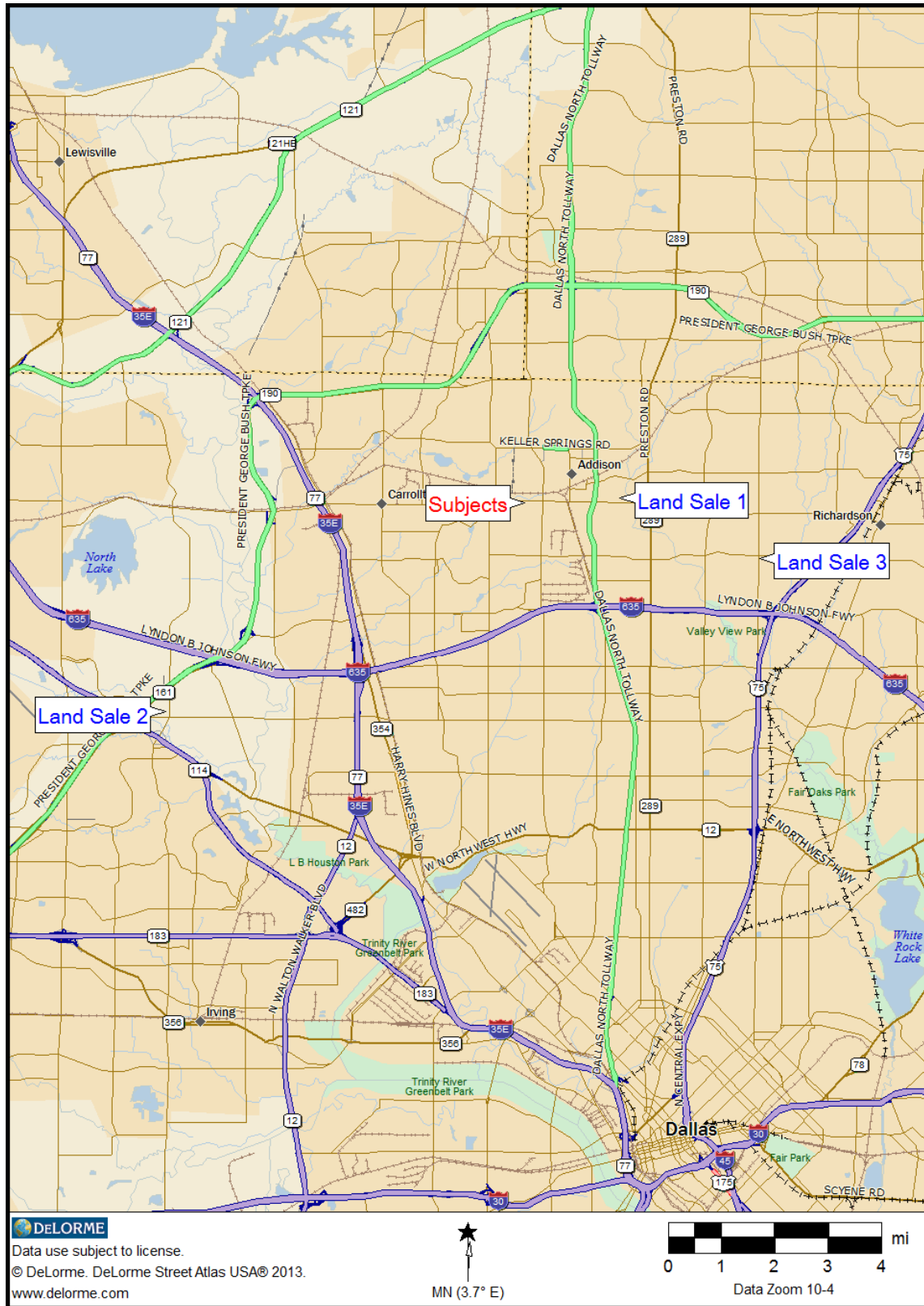

Land Sale 1

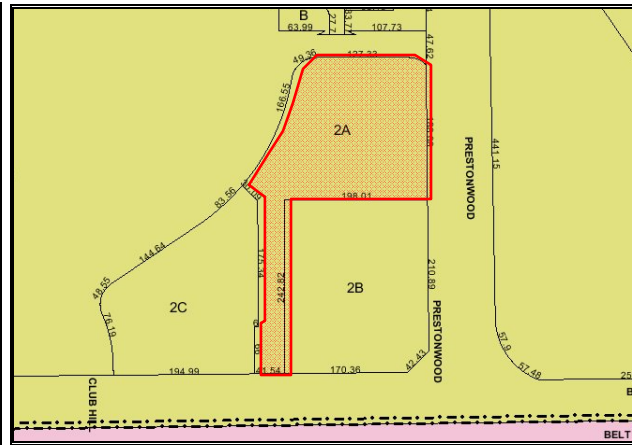

Location	Adj. to NW/c Belt Line Road and Prestonwood Boulevard Dallas, Dallas County, Texas
Mapsco	DA-15-A
Legal Description	Being a 1.1773 acre tract of land out of Lot 2, Block B/8222, Official City Numbers, of Prestonwood Town Center II
Grantor	Beltline Stampede, Ltd.
Grantee	784 Gunclub, LLC
Date of Sale	February 27, 2013
Record Data	
Document No.	201300061040
Consideration	\$800,000
Conditions of Sale	Cash to the seller
Land Area	
Acres	1.177
Square Feet	51,285
Price Per SF	\$15.60
Price Per AC	\$679,497
Zoning	MU-3 (SAH) (Mixed-Use District)
Comments	This tract is located adjacent to the northwest corner of Belt Line Road and Prestonwood Boulevard. The site wraps a bank branch, and has approximately 42 feet of frontage on Belt Line Road and approximately 188 feet of frontage along Prestonwood Boulevard. The transaction was reportedly an investment purchase with no marketing or outside brokerage assistance. One party stated that a slightly higher price was paid for the site as it was the last piece of vacant land in the area. This site previously transacted for \$570,000, or \$11.12 per square foot in August of 2011.
Confirmed	JS

Land Sale 2

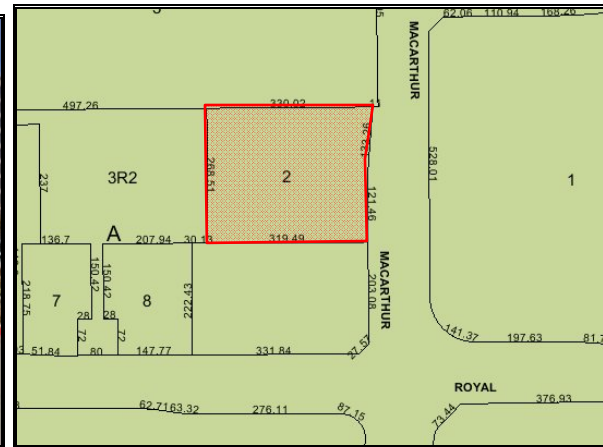

Location	E/s North MacArthur Boulevard, approx. 225 feet north of Royal Lane Irving, Dallas County, Texas
Mapsko	DA-21B-E
Legal Description	Lot 2, Block A of Makko MacArthur I, an addition to the City of Irving
Grantor	Makko MacArthur I, LP
Grantee	In-N-Out Burgers, Corp.
Date of Sale	April 6, 2011
Record Data	
Document No.	201100087823
Consideration	\$1,555,000
Conditions of Sale	Cash to the seller
Land Area	
Acres	2.021
Square Feet	88,024
Price Per SF	\$17.67
Price Per AC	\$769,515
Zoning	PUD-Planned Unit Development
Comments	This tract is located in a highly concentrated commercial district near the confluence of two major regional freeways. Subsequent to the sale, the property was developed with a nationally branded fast food restaurant.
Confirmed	JCW

Land Sale 3



Location	E/s Coit Road, approx. 250 feet south of Spring Valley Road Dallas, Dallas County, Texas
Mapsc0	DA-16-K
Legal Description	Being Lots 4 and 5, in Block A/7758 of Willingham Coit Road Addition
Grantor	WPC Coit/SV, LP
Grantee	Firebrand Properties, LP
Date of Sale	June 21, 2010
Record Data	
Document No.	201000155147
Consideration	\$735,000
Conditions of Sale	Cash to the seller
Land Area	
Acres	0.643
Square Feet	28,000
Price Per SF	\$26.25
Price Per AC	\$1,143,450
Zoning	SUP-315 (Special Use Permit)
Comments	This tract, with 160 feet of frontage on Coit Road, was formerly improved with an active clothing retailer. Following the razing of the original improvements, the site was replatted and sold in fee to the current owner. The property has been subsequently improved with a fast food restaurant.
Confirmed	KH

LAND VALUATION

LAND SALES SUMMARY					
Sale No.	Location	Size		Price/SF	Date of Sale
		SF	AC		
1	Adj. to NW/c Belt Line Road and Prestonwood Boulevard	51,285	1.177	\$15.60	Feb-13
2	E/s North MacAuthur Boulevard, approx. 225 feet north of Royal Lane	88,024	2.021	\$17.67	Apr-11
3	E/s Coit Road, approx. 250 feet south of Spring Valley Road	28,000	0.643	\$26.25	Jun-10
Subject	4080 Belt Line Road	66,184	1.519		

The comparable sales range in size from 0.643 acres to 2.021 acres, in price from \$15.60 to \$26.25 per square foot, and were transacted between June 2010 and February 2013.

Comparable Adjustments

Adjustments to the comparables are considered in the categories of financing terms, conditions of sale, market conditions/time, location, size, zoning, and availability of utilities and other factors. Adjustments for each factor are typically made after a comparison indicates the appropriate direction and size of each adjustment. Adjustments are based on experience and extrapolations of market indicators.

EXPLANATION OF ADJUSTMENTS

Property Interest Transferred

Adjustments are not necessary.

Financing Terms

Adjustments are not necessary.

Sale Conditions

Adjustments for conditions of sale usually reflect the motivations of the buyer and the seller. Any sales that reflect unusual sale conditions are adjusted accordingly and the circumstances of these non-arm's length transactions are detailed on the sale summary pages. No adjustments are warranted as each of the sales transpired with no reported uncommon sale conditions.

Market Conditions

The sales occurred between June 2010 and February 2013. Adjustments for market conditions are applied if property values have increased or decreased since the transaction dates. Based on our observations and analysis, real estate has appreciated approximately three percent annually since mid-2010. Each sale is adjusted accordingly.

Location

An adjustment for location within a market area may be required when the locational characteristics of a comparable property are different from those of the property. Most comparable properties in the same market area have similar locational characteristics, but variations may exist within that area of analysis. Each of the sales is located in respective suburban locations in areas of highly developed commercial corridors, warranting no adjustments.

Access

Access is defined as the points, or number of points available for ingress/egress to the subject site, or ease of access to a site from major routes in the area. Sale properties are adjusted based on their inferiority/superiority as compared with the subject. The subject has access from one curb cut along the eastern line of Runyon Road. Sale 1 is inferior and is adjusted +10%. Sales 2 and 3 are similar with no adjustment.

Frontage

Frontage is the number of feet of frontage along the subject roadway or roadways. Sale properties are adjusted based on their inferiority/superiority as compared with the property. The subject has frontage along two roadways. Sales 2 and 3 have frontage along one roadway and are adjusted +5%. Sale 1 is similar as compared to the subject with no adjustment.

Exposure

Exposure is the visibility of the subject to the roadways or neighboring properties. The subject has average exposure from Belt Line Road. Sales 1 and 3 are adjusted +5%. Sale 2 requires no adjustment.

Land Sales - Traffic Exposure		
Sale No.	Location	Vehicle Count
1	Adj. to NW/c Belt Line Road and Prestonwood Boulevard	39,700
2	E/s North MacAuthur Boulevard, approx. 225 feet north of Royal Lane	49,400
3	E/s Coit Road, approx. 250 feet south of Spring Valley Road	42,900
<i>Subject</i>	<i>4080 Belt Line Road</i>	<i>52,200</i>

Size

The subject is 1.519 acres. The size adjustment is based on the premise that, in general, the larger the tract, the less its selling price on a per unit basis. Typically an approximate 5% - 15% adjustment for each doubling/halving (100%) in size is adequate. A 5% adjustment for each doubling/halving (100%) in size is utilized. Each sale is adjusted accordingly for size.

Zoning

The property is zoned PD, Planned Development, by the town of Addison. All of the sales are similar as compared to the subject in terms of designation and highest and best use, and do not require adjustments.

Utilities

Electricity, water, sewer, and phone services are available to the subject. Each of the sales has water, sewer, electricity and phone service available to the respective sites and are not adjusted.

Topography

The terrain is characterized as mostly level. Drainage is appears to be graded. According to FEMA flood hazard map 48113C0180J, the subject is determined to be outside the 100-year floodplain, being within Zone X. Each of the comparable sales is located outside of designated flood area, warranting no adjustments.

Utility

In terms of utility, Sale 1 has a large portion of the site located in a narrow, elongated area that is unsuitable for development, dictating a +10% adjustment for inferior utility. The remaining sales are of sufficient size and shape to support numerous development types, requiring no adjustments.

LAND VALUATION

LAND SALES DATA

The grid below outlines the pertinent characteristics of each of the comparables and the adjustments applied.

LAND SALES ADJUSTMENTS			
Sale No.	1	2	3
No. of Acres	1.177	2.021	0.643
Size - SF	51,285	88,024	28,000
Sale Date	Feb-13	Apr-11	Jun-10
Sale Price	\$800,000	\$1,555,000	\$735,000
Sale Price Per SF	\$15.60	\$17.67	\$26.25
Rights Conveyed	0%	0%	0%
Financing	0%	0%	0%
Sale Conditions	0%	0%	0%
Market Conditions	3%	8%	11%
Adjusted Price	\$16.07	\$19.08	\$29.14
Location	0%	0%	0%
Access	10%	0%	0%
Frontage	0%	5%	5%
Exposure	5%	0%	5%
Size	-1%	2%	-6%
Zoning	0%	0%	0%
Utilities	0%	0%	0%
Topography	0%	0%	0%
Utility	10%	0%	0%
Net Adjustment	24%	7%	4%
Adjusted Price/SF	\$19.93	\$20.42	\$30.31

Land Value Opinion

After the adjustment process, the comparables range from \$19.93 to \$30.31 per square foot. Based on the foregoing, the market data support an estimated fee simple value of \$20.00 per square foot for subject, with an indicated value opinion of the subject property of \$1,316,150. The existing easement area of 502 square feet is valued at 25% of fee simple, which equates to \$2,510 (502 SF x \$20.00 x 25%).

Total Land Area						
No. of Square Feet			\$/SF			Indicated Value
65,682	x		\$20.00	=		\$1,313,640
502	x	\$20.00	x	25%	=	\$2,510
66,184						\$1,316,150

COST APPROACH

The purpose of the cost approach is to develop an opinion of the cost to construct a reproduction of, or replacement for, the existing structure and then deduct all accrued depreciation in the property being appraised from the cost new of the reproduction or replacement structure. When the value of the land and an entrepreneurial profit, if appropriate, are added to this figure, the result is an indication of the value of the leased fee interest in the property.

When applicable, the cost approach reflects market thinking by recognizing that market participants relate value to cost. Investors tend to judge the value of an existing structure by considering the prices and rents of similar buildings and the cost to create a new building with optimal physical and functional utility. Investors adjust the prices they are willing to pay by estimating the costs to bring an existing structure up to the level of physical and functional utility they desire.

The cost approach is based on the estimated replacement cost of the improvements less depreciation from all causes, to which is added the market value of the land based on comparable sales.

REPLACEMENT COST

The cost estimates in the following tables are abstracted from the *Marshall Valuation Service*. The *Marshall Valuation Service* is a national cost index providing cost data for determining replacement costs of buildings and other improvements, and is published by Marshall & Swift, LP.

SECTION 13 PAGE 14
May 2012

CALCULATOR METHOD

RESTAURANTS (350)								
C	Excellent	Individual design, highly ornamental exterior	High-quality detail, best acoustics, carpeted, deluxe quality	Special lighting effects, tiled restrooms, good fixtures	Complete H.V.A.C.	2,590.14	20.05	240.63
	Very good	Individual design, brick, good metal and glass, ornamentation	Typically best chain restaurants, carpeted lounge and dining room	Good lighting/restrooms with good-quality fixtures and tile	Complete H.V.A.C.	2,006.19	15.53	186.38
	Good	Brick, concrete or metal and glass panels, ornamentation	Typical chain restaurant or coffee shop, vinyl and ceramic floors	Good lighting and service outlets, tiled restrooms	Complete H.V.A.C.	1,561.96	12.09	145.11
	Average	Brick, block, tilt-up, plain building, stock plans	Typical neighborhood restaurant, vinyl composition, small kitchen	Adequate lighting and outlets, small restrooms	Complete H.V.A.C.	1,217.52	9.43	113.11
	Low cost	Cheap brick or block, very plain, low-cost front	Low-cost short order cafe, minimum finish, asphalt tile	Minimum lighting and outlets, minimum plumbing	Forced air and ventilation	882.00	6.83	81.94
D	Excellent	Individual design, highly ornamental exterior, stone veneer	High-quality detail, best acoustics, carpeted, deluxe quality	Special lighting effects, tiled restrooms, good fixtures	Complete H.V.A.C.	2,463.45	19.07	228.86
	Very good	Individual design, brick veneer, good metal and glass, ornamentation	Typically best chain restaurants, carpeted lounge and dining room	Good fixtures, good restrooms w/good-quality fixtures and tile	Complete H.V.A.C.	1,882.95	14.58	174.93
	Good	Stucco or siding, metal and glass, some ornamentation	Typical chain restaurant or coffee shop, vinyl and ceramic floors	Good lighting and service outlets, tiled restrooms	Complete H.V.A.C.	1,448.51	11.21	134.57
	Average	Stucco or siding, plain building and front, stock plans	Typical neighborhood restaurant, vinyl composition, small kitchen	Adequate lighting and outlets, small restrooms	Complete H.V.A.C.	1,115.80	8.64	103.66
	Low cost	Cheap stucco or siding, very plain	Low-cost short order cafe, min. finish	Minimum lighting and plumbing	Forced air/vent.	792.66	6.14	73.64

For building structure and components, the calculator method is utilized. The improvements most closely resemble an average cost quality Class D Restaurant, as described in the Marshall Valuation Service Handbook, Section 13, Page 14. To the base cost, various multipliers are applied to reflect local market conditions and changes in construction costs.

COST APPROACH

DIRECT COSTS

Base Building Costs

<u>Component</u>	<u>Area</u>	<u>Base Cost</u>	
restaurant	6,351 SF	\$ 113.11	\$ 718,000

Improvements cost before adjustments for time, location, and perimeter **\$ 718,000**

<u>Total Base Costs</u>	<u>Multipliers</u>				
	<u>Current</u>	<u>Local</u>	<u>Perimeter</u>		
\$718,000	x 1.04	x 0.91	x 1.00	\$	680,000

Site Improvements

Patio, Parking, Drives & Sidewalks	\$ 285,000
Landscaping, Signage & Lighting	\$ 33,000
Total Site Improvements	\$ 318,000

Total Direct Costs **\$ 998,000**

INDIRECT COSTS

Architectural, Legal, Engineering Fees, Permits, etc.	@ 4%	\$ 40,000
Total Indirect Costs		\$ 40,000

ENTREPRENEURIAL INCENTIVE **\$ 83,000**

**Total Direct and Indirect Costs
or Total Construction Costs** **\$ 1,121,000**

Replacement Cost New (RCN) **\$ 1,121,000**

The total replacement construction costs include contractor profit, architect fees, engineering fees and permits, but exclude land cost, and amount to \$1,121,000, or \$176.51 per square foot. This cost is within the range for average to good quality construction costs, as estimated by the Marshall and Swift Cost Valuation Service Cost Manual, Section 13, Page 14 (after adjustment for time and location).

DEPRECIATION

Appropriate items of depreciation must be deducted from the cost to replace the subject improvements as estimated above. Depreciation in this case is defined as "a loss in value from any cause". The accrued depreciation applicable is typically broken down as follows:

a. Physical Depreciation

Curable - refers to items of deferred maintenance.

Incurable - deterioration that is not practical or economically feasible to correct.

b. Functional Obsolescence - adverse effect on value resulting from defects in design, can also be caused by changes that, over time, have made some aspects of a structure, material, or design obsolete by current standards.

Curable - to be curable the cost must be at least offset by the anticipated increase in value.

Incurable - deficiencies or superadequacies not economically feasible to correct.

c. External (Economic) Obsolescence - result of diminished utility of a structure due to negative influences from outside the site and is always incurable. The total loss in value due to such influences is allocated between the land and the improvements with only that portion attributable to the improvements deducted from the current replacement cost.

Curable Physical

No items of deferred maintenance were noted at the inspection.

Incurable Physical

A property suffers from deterioration as a result of the aging process. The method of estimating accrued depreciation utilized here is the modified economic age-life method. Briefly, this method consists of first estimating the cost to cure all curable items, deducting that figure from the replacement cost, and then applying to the remainder the deduction based on the ratio of effective age to total economic life.

COST APPROACH

It was previously estimated in the subject property section that the subject has an aggregate effective age of 21 years and a remaining economic life of 14 years. Thus, the physical depreciation is calculated as follows:

DEPRECIATION

Replacement Costs		\$ 1,121,000
Value of Improvements		\$ 1,121,000

Total Economic Life	35 years
Remaining Economic Life	14 years
Effective Age	21 years

Depreciation Percentage

Applied Percentage - M&S, Sec. 97, Pg. 24 \approx 42%

Less: Incurable Items

	\$1,121,000	x	42.0%		\$ 471,000
Depreciated Value					\$ 650,000

The total physical depreciation is \$471,000.

External and Functional Obsolescence

Over the past 15 years, the Addison market has been saturated with restaurant buildings. A reduction in rents is apparent due to the oversupply of space and a preponderance of competition. Due to the quantity of listings and foreclosures of restaurant buildings in the market, the subject suffers from some external obsolescence. External or economic obsolescence is regarded as the result of the diminished utility of a structure due to negative influences from outside the site, whereas functional obsolescence can be described as an impairment of functional efficiency or capacity inherent in a property. When possible these forms of obsolescence are considered separately; however, due to their combinatorial nature and difficulty in distinguishing the two in the case of the subject, these two forms are considered jointly.

The current market conditions as demonstrated in the income capitalization approach result in external obsolescence as shown by the difference in the income capitalization approach and the replacement cost. Present market conditions indicate that the subject improvements are not a feasible use. In this regard, a portion of the difference between the income and cost approaches must be labeled as economic obsolescence.

The amount of additional depreciation from external obsolescence is calculated as follows:

COST APPROACH

External Obsolescence		
Land Value	\$	1,316,150
Required Return on Land Investment		0.06
Income Attributable to Land	\$	78,969
Net Operating Income to Land & Improvements	\$	101,159
Less: Income Attributable to Land	\$	78,969
Net Operating Income Attributable to Improvements	\$	22,190
Estimated Reproduction Cost New of Improvements	\$	1,121,000
Less: Physical Deterioration	\$	471,000
Depreciated cost of Improvements Before External Obsolescence	\$	650,000
Required Return on Improvements		0.09
Required net Operating Income of Improvements	\$	58,500
Less: Net Operating Income Attributable to Improvements	\$	22,190
Total Rent Loss Attributable to Improvements	\$	36,310
Capitalized Value of Rent Loss @ 8.0%	\$	453,875

The total depreciation from external obsolescence is \$453,875. The total affect of physical depreciation and external obsolescence on the replacement costs is calculated as follows:

COST APPROACH

COST APPROACH SUMMARY

Estimated Total Construction Costs	\$	1,121,000
Less: Depreciation	\$	471,000
Less: External/Functional Obsolescence	\$	<u>453,875</u>
 Total Depreciated Value of Improvements	 \$	 196,125
 Plus: Indicated Value of Land	 \$	 1,316,000
 Final Opinion of Value via the Cost Approach	 \$	 1,512,125
Rounded	\$	1,512,125

COST SUMMARY

As the subject consists of a restaurant (totaling 6,351 square feet), the costs are applied to this property. The estimated costs of the entire property, including land, and improvements are **\$1,512,125**.

SALES COMPARISON APPROACH

The sales comparison approach is a method of estimating market value whereby a property is compared with similar properties that have sold recently. One premise of the sales comparison approach is that the market will determine a price for the property being appraised in the same manner that it determines the price of comparable, competitive properties. The principle of substitution is basic in this approach as it implies that a prudent person will not pay more for a property than an acceptable alternative available in the market.

In the sales comparison approach, the property appraised is compared with known prices paid for similar properties in the open market. Typically, for most properties, the most common units of comparison used are the overall price paid per unit, and sales price per square foot.

The following summary information on improved sales judged to be comparable to the property appraised is included herein, establishing the probable value of the subject property by the sales comparison approach.

SALES COMPARISON APPROACH

IMPROVED SALES MAP

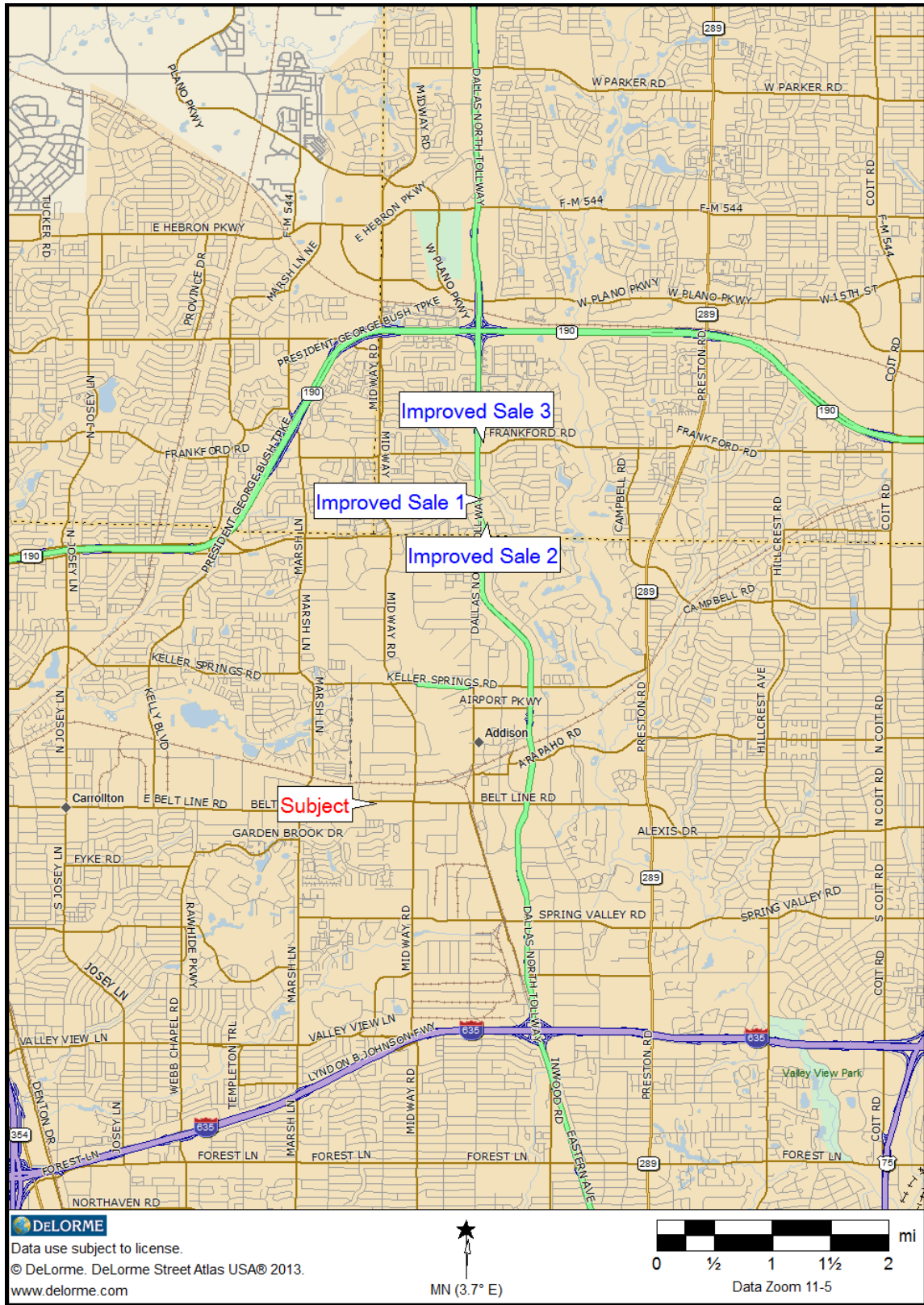

SALES COMPARISON APPROACH

Improved Sale 1



Location	17795 Dallas Parkway Dallas, Collin County, Texas
Mapsc	DA-4-L
Grantor	Sullivan's-Austin, L.P.
Grantee	McGray Group III, LLC
Record Data	
Date	July 2, 2012
Document No.	20120703000800850
Consideration	\$1,800,000
Sale Price/SF	\$159.74
Conditions of Sale	Cash (or cash equivalent) to the seller
Physical Description	
Land Area	
Acres	1.97 AC
Square Feet	85,682 SF
Building Coverage	13.15%
Gross Building Area	11,268 SF
Year Built	1998
Occupancy @ Sale	0%
Description	Restaurant
Condition	Average
Comments	This property is located at the southwest corner of Dallas Parkway and Briargrove Lane. This property is a restaurant (formerly Sullivan's Steakhouse). This property has a two-story, parking garage. According to the broker, the transaction was a 'quick sale' for a distressed grantor; the grantor needed to liquidate this property quickly. The broker stated that this property is currently under contract for \$2,700,000 or \$239.62 per square foot (calculated).

SALES COMPARISON APPROACH

Improved Sale 1 (Continued)

Pro-Forma Operating Statement - Sale No. 1			
Income Data		Total	\$/SF
Gross Rental Income	\$	225,360	\$ 20.00
Less: Expense Reimbursement	\$	91,271	\$ 8.10
Less: Vacancy @ 10%	\$	31,663	\$ 2.81
Effective Gross Income	\$	284,968	\$ 25.29
Total Expenses	\$	119,441	\$ 10.60
Net Operating Income	\$	165,527	\$ 14.69

Source: Appraiser's estimate & broker's data

Units of Comparison	
Overall Rate (Ro)	9.20%
Sales Price/SF	\$159.74
NOI/EGI Ratio	58.09%

SALES COMPARISON APPROACH

Improved Sale 2



Location	17548 Dallas Parkway Dallas, Collin County, Texas
Mapsco	DA-4-L
Grantor	Bloomin Brands Inc.
Grantee	National Retail Properties, LP
Record Data	
Date	March 14, 2012
Document No.	20120319000317640
Consideration	\$2,879,104
Sale Price/SF	\$432.62
Conditions of Sale	Cash (or cash equivalent) to the seller
Physical Description	
Land Area	
Acres	1.41 AC
Square Feet	61,594 SF
Building Coverage	10.80%
Gross Building Area	6,655 SF
Year Built	2000
Occupancy @ Sale	100%
Description	Restaurant
Condition	Good
Comments	This property is located along the eastern line of Dallas Parkway, south of Trinity Mills Road. This property is a restaurant (Carrabba's). This transaction was a sale-leaseback of 67 restaurants for \$192,900,000. Specific values were not allocated to each restaurant; however, the average compensation of each restaurant is \$2,879,104 (arithmetically).

SALES COMPARISON APPROACH

Improved Sale 2 (Continued)

Pro-Forma Operating Statement - Sale No. 2		
Income Data	Total	\$/SF
Gross Rental Income	\$ 232,925	\$ 35.00
Less: Expense Reimbursement	\$ 82,522	\$ 12.40
Less: Vacancy @ 5%	\$ 15,772	\$ 2.37
Effective Gross Income	\$ 299,675	\$ 45.03
Total Expenses	\$ 108,477	\$ 16.30
Net Operating Income	\$ 191,198	\$ 28.73

Source: Appraiser's estimate & broker's data

Units of Comparison	
Overall Rate (Ro)	6.64%
Sales Price/SF	\$432.62
NOI/EGI Ratio	63.80%

SALES COMPARISON APPROACH

Improved Sale 3



Location	18438 Dallas Parkway Dallas, Collin County, Texas
Mapsc0	DA-4-G
Grantor	Relentless Properties, LLC
Grantee	Dan Quinlan Trust
Record Data	
Date	December 9, 2011
Document No.	20111209001332350
Consideration	\$1,600,000
Sale Price/SF	\$123.70
Conditions of Sale	Cash (or cash equivalent) to the seller
Physical Description	
Land Area	
Acres	2.56 AC
Square Feet	111,387 SF
Building Coverage	11.61%
Gross Building Area	12,934 SF
Year Built	1998
Occupancy @ Sale	0%
Description	Restaurant
Condition	Average
Comments	This property is located along the eastern line of Dallas Parkway, north of Frankford Road. This property is a restaurant (formerly Smith & Wollensky Steakhouse). According to the broker, the transaction reflected a motivated seller.

SALES COMPARISON APPROACH

Improved Sale 3 (Continued)

Pro-Forma Operating Statement - Sale No. 3			
Income Data		Total	\$/SF
Gross Rental Income	\$	258,680	\$ 20.00
Less: Expense Reimbursement	\$	89,245	\$ 6.90
Less: Vacancy @ 10%	\$	34,792	\$ 2.69
Effective Gross Income	\$	313,132	\$ 24.21
Total Expenses	\$	126,753	\$ 9.80
Net Operating Income	\$	186,379	\$ 14.41

Source: Appraiser's estimate & broker's data

Units of Comparison	
Overall Rate (Ro)	11.65%
Sales Price/SF	\$123.70
NOI/EGI Ratio	59.52%

SALES COMPARISON APPROACH

Summary of Improved Sales					
Sale No.	Address	YOC	Size SF	Price/SF	Date
1	17795 Dallas Parkway Dallas, Collin County, Texas	1998	11,268	\$159.74	Jul-12
2	17548 Dallas Parkway Dallas, Collin County, Texas	2000	6,655	\$432.62	Mar-12
3	18438 Dallas Parkway Dallas, Collin County, Texas	1998	12,934	\$123.70	Dec-11

The sales in the sample were selected from a larger group as being most similar in overall physical characteristics as compared to the subject. The sale sample ranges in price from \$123.70 to \$432.62 per square foot, range in size from 6,655 square feet to 12,934 square feet, and were constructed between 1998 and 2000.

Comparable Adjustments

Adjustments to the comparables are considered in the categories of financing terms, conditions of sale, market conditions/time, location, size, zoning, and availability of utilities and other factors. Adjustments for each factor are typically made after a comparison indicates the appropriate direction and size of each adjustment. Adjustments are based on experience and extrapolations of market indicators.

EXPLANATION OF ADJUSTMENTS

Rights Conveyed

The rights conveyed of the sales represent fee simple ownership for each of the comparable sales, resulting in no required adjustment.

Financing

The sales were purchased with cash, or third party financing which do not require adjustments.

Sale Conditions

Sales 1 and 3 represent motivated sellers and are adjusted +20%. Sale 2 was part of a large portfolio of properties and is adjusted -20%.

Market Conditions

The sales were transacted from December 2011 to July 2012. Adjustments for market conditions are applied if property values have increased or decreased since the transaction dates. Based on our observations and analysis, real estate has appreciated approximately three percent annually since mid 2010. The sales are adjusted accordingly.

SALES COMPARISON APPROACH

Location

The subject is located at the southeast corner of Belt Line Road and Runyon Road, in the city of Addison, Dallas County. The sales are similarly located as the subject and do not require adjustments for location.

Physical Characteristics

Physical aspects are considered for each sale, and include size, age, condition, and quality.

Access

Access has significant bearing on real estate in the market. Access is defined as the points, or number of points available for ingress/egress to the subject site or ease of access to the site from abutting roadways. Sale properties are adjusted based on their inferiority/superiority as compared with the subject. The sales are similar in access as compared to the subject, with no adjustment.

Exposure

Exposure is a function of traffic volume or drive-by business potential. Sale properties are adjusted based on their inferiority/superiority as compared with the subject. The sales are adjusted -5% for superior exposure compared to the subject.

Size

The subject comprises 6,351 square feet of total building area. The sales range in size from 6,655 square feet to 12,934 square feet. The size adjustment is based on the premise that, in general, the larger the tract, the less its selling price on a per unit basis. Typically, a 5%-15% adjustment for each doubling or halving in size compared to the subject is appropriate. A factor of approximately 5% is used. The sales are adjusted 4%, 0%, and 5%, respectively for size.

Age

The subject was built in 1993. Sale 1 was built in 1998, Sale 2 in 2000, and Sale 3 in 1998. The subject's effective age is estimated at 21 years, with significant remaining economic life. Inadequate market data are available for an analysis to isolate precise factors for perceived differences in effective age. However, effective age, in addition to the actual age of structures, is considered an important consideration from a buyer standpoint. The adjustment is calculated at 1% for every 3 years difference of effective age. Sale 1 is adjusted -2%, Sale 2 is adjusted -2%, and Sale 3 is adjusted -2%.

Condition

The improvements are in average condition. The sales are similar as compared to the subject and are not adjusted.

SALES COMPARISON APPROACH

Quality

Due to the varying construction designs and conditions of the comparables, a degree of subjectivity is likewise required in comparing the construction quality of the sale properties to the subject. Inherent in this adjustment is recognition of the aesthetic appeal and finish of each property. The subject is of average quality construction. The sales are similar as compared to the subject and are not adjusted.

ADJUSTMENTS

The following grid summarizes the adjustment process.

IMPROVED SALES ADJUSTMENTS			
Sale No.	1	2	3
Year Built	1998	2000	1998
Size SF	11,268	6,655	12,934
Sale Date	Jul-12	Mar-12	Dec-11
Sale Price	\$1,800,000	\$2,879,104	\$1,600,000
Sale Price Per SF	\$159.74	\$432.62	\$123.70
Rights Conveyed	-0-	-0-	-0-
Financing	-0-	-0-	-0-
Sale Conditions	20%	-20%	20%
Market Conditions	5%	6%	6%
Adjusted Price	\$201.28	\$366.86	\$157.35
Location	-0-	-0-	-0-
Access	-0-	-0-	-0-
Exposure	-5%	-5%	-5%
Size	4%	-0-	5%
Age	-2%	-2%	-2%
Condition	-0-	-0-	-0-
Quality	-0-	-0-	-0-
Net Adjustment	-3%	-7%	-2%
Adjusted Price/SF	\$195.24	\$341.18	\$154.20

Reconciliation

The adjusted sales range from \$154.20 to \$341.18 per square foot, with an average of \$230.21 per square foot and a median of \$195.24 per square foot. Each of the comparable sales is considered as indicators of value. Given the size, quality, condition, and location of the subject a unit value of \$225.00 per square foot is supported by the sale data. This equates to an indicated value of **\$1,429,000**.

Calculation: 6,351 SF x \$225.00/SF = \$1,429,000

INCOME CAPITALIZATION APPROACH

The premise of the income capitalization approach is that an indication of value can be derived by capitalizing the net income a property will produce - under prudent management - at an appropriate rate which reflects the current market conditions, trends, and investor requirements.

The income capitalization approach consists of the following steps:

- Market Analysis: Research the market to determine relevant income parameters i.e., rental rate, vacancy rates, absorption trends, escalations, allowances, and other factors.
- Estimate of Operations: Estimate potential gross income. Then, deduct a vacancy and collection loss allowance to derive effective gross income. Finally, estimate and deduct expenses of operation to derive net operating income.
- Capitalization: Select an applicable capitalization method and technique. Develop the appropriate rate or rates, and capitalize the net operating income or income stream to derive an indication of value.

As described above, the analysis of the market includes thorough research of the market to determine relevant income parameters i.e., rental rate, vacancy rates, absorption trends, escalations, allowances, and other factors. An industry forecast study from the National Restaurant Association literature was consulted for a market analysis.



2013 Restaurant Industry POCKET FACTBOOK

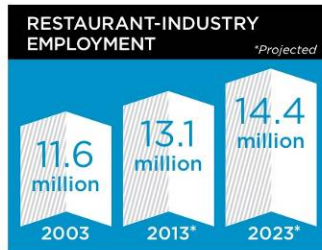

Locations 980,000

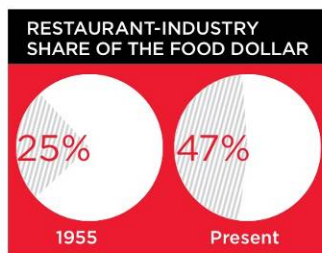

2013 Industry Sales Projection:
\$660.5 Billion **Projected*

Category	2013 Sales (Billion \$)
Commercial	\$602.5
Eating Places	441.9
Bars and Taverns	19.5
Managed Services	45.6
Lodging Place Restaurants	33.1
Retail, Vending, Recreation, Mobile	62.4
Other	58.0

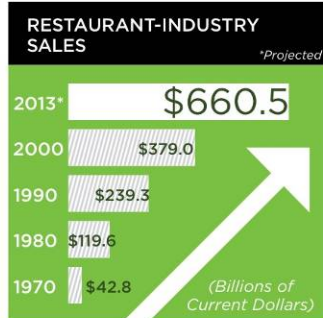

America's Restaurants:

SMALL BUSINESSES WITH A LARGE IMPACT ON OUR NATION'S ECONOMY

- ▶ Restaurant-industry sales are projected to total **\$660.5 billion** in 2013 and equal 4% of the U.S. gross domestic product.
- ▶ Restaurant-industry job growth outpaced the overall economy in 13 consecutive years, from 2000 to 2012.
- ▶ The restaurant industry is projected to employ **13.1 million** people in 2013, or nearly 10% of the U.S. workforce.
- ▶ The restaurant industry is expected to add **1.3 million** jobs over the next decade, with employment reaching **14.4 million** by 2023.
- ▶ **93%** of eating-and-drinking place businesses have fewer than 50 employees.
- ▶ More than **seven out of 10** eating-and-drinking place establishments are single-unit operations.
- ▶ Average unit sales in 2010 were **\$849,000** at fullservice restaurants and **\$753,000** at quickservice restaurants.

CORNERSTONES OF CAREER AND ENTREPRENEURIAL OPPORTUNITIES

- ▶ **One-half** of all adults have worked in the restaurant industry at some point during their lives, and **one out of three** adults got their first job experience in a restaurant.
- ▶ **80%** of restaurant owners said their first job in the restaurant industry was an entry-level position.
- ▶ **59%** of first-line supervisors/managers of food preparation and service workers in 2011 were women, **18%** were black or African-American and **15%** were of Hispanic origin.
- ▶ Restaurants employ more minority managers than any other industry.

- ▶ The number of black or African-American-owned restaurant businesses jumped **188%** between 1997 and 2007, compared to a **36%** increase for all restaurant businesses.
- ▶ The number of Hispanic-owned restaurant businesses increased **80%** between 1997 and 2007, while the number of Asian-owned restaurant businesses grew **60%**.

AN ESSENTIAL PART OF DAILY LIFE

- ▶ **93%** of adults said they enjoy going to restaurants.
- ▶ **45%** of adults said restaurants are an essential part of their lifestyle.
- ▶ **68%** of adults said their favorite restaurant foods provide flavor and taste sensations which cannot easily be duplicated in their home kitchen.
- ▶ **79%** of adults said going out to a restaurant with family or friends gives them an opportunity to socialize and is a better way for them to make use of their leisure time rather than cooking and cleaning up.

RESTAURANTS BY THE NUMBERS

- ▶ **\$1.8 Billion** Restaurant-industry sales on a typical day in 2013.
- ▶ **86** Percent of adults who said there are more healthy options at restaurants than there were two years ago.
- ▶ **34** Percent of adults who said they have used the Internet to search for nutritional information about restaurant food.
- ▶ **44** Percent of adults who said they would be likely to utilize a self-service ordering terminal if it was offered by a quickservice restaurant.
- ▶ **66** Percent of adults who said they are more likely to patronize a restaurant that offers a customer loyalty and reward program.
- ▶ **79** Percent of adults who said they would like to receive a restaurant gift card or gift certificate on gift occasions.
- ▶ **\$2,620** Average household expenditure for food away from home in 2011.
- ▶ **\$83,947** Sales per full-time-equivalent non-supervisory employee at eating-and-drinking places in 2011.
- ▶ **79** Percent of adults who said they would consider dining out more often if menu prices were lower during off-peak times.
- ▶ **40** Percent of adults who said they would be likely to utilize a smartphone application if it was offered by a quickservice restaurant.
- ▶ **71** Percent of adults who said they are more likely to visit a restaurant that offers locally-produced food items.
- ▶ **32** Percent of adults who said they would likely use a mobile or wireless payment option if it was offered by a fullservice restaurant.

▶ Visit Restaurant.org/Forecast to view the 2013 Restaurant Industry Forecast video

Thank you to our National Restaurant Association 2013 Restaurant Industry Forecast sponsor



INCOME CAPITALIZATION APPROACH

Texas

RESTAURANT INDUSTRY AT A GLANCE



Restaurants are a driving force in Texas's economy. Their sales generate tremendous tax revenues. They provide jobs and build careers for thousands of Texans. Restaurants also provide healthful options for their guests, give back to their communities and work to reduce their impact on the environment. Visit Restaurant.org for more information.

39,296
LOCATIONS

In 2011, there were 39,296 eating and drinking places in Texas.

\$40.8 billion
IN SALES

In 2013, Texas's restaurants are projected to register \$40.8 billion in sales.

1,074,200
TEXANS

In 2013, restaurants account for 1,074,200 jobs in Texas — 10% of employment in the state.

EVERY \$1 SPENT ...

in Texas's restaurants generates an additional **\$1.23** in sales for the state economy.

EVERY \$1 MILLION SPENT ...

in Texas's restaurants generates an additional **26.3** jobs in the state.

AND IN 2023 ...

Restaurants in Texas are projected to employ **1,245,000** people. (**15.9%** job growth — or **170,800** jobs over 2013)

HOW BIG IS AMERICA'S RESTAURANT INDUSTRY?

980,000
LOCATIONS
Serving millions of Americans per day



\$660.5 billion
IN SALES
4% of U.S. GDP



13.1 million
PEOPLE
10% of workforce



Restaurant.org | Restaurantville.com

© 2013 National Restaurant Association. All rights reserved.

National Restaurant Association - 2013 Fullservice

The fullservice restaurant segment is projected to post its third consecutive year of real sales growth this year. The National Restaurant Association expects fullservice sales to total \$208.1 billion in 2013, up 2.9 percent from \$202.2 billion last year. In inflation-adjusted terms, total fullservice sales are projected to edge up 0.2 percent in 2013, down slightly from a real gain of 0.4percent in 2012.

Challenges ahead

Fullservice restaurant operators expect to face many of the same challenges as they did in 2012, including cost control, health care and economic uncertainty. One of four operators in each of the three fullservice segments identified food costs as their top challenge for 2013. Twenty-five percent of family-dining operators said complying with health-care reform would be their top challenge, as did about 10 percent of casual- and fine-dining restaurateurs. Fine-dining operators were more concerned about the economy; 28 percent said it would be their No. 1 challenge for the year.

Positive perspective

Despite the uncertainties, more than nine of 10 operators expect sales to either improve or stay the same this year, compared to 2012. Fine-dining operators were the most optimistic. Fifty-seven percent expect stronger sales this year, and only 5 percent expect sales to decline. Casual-dining operators are only slightly less bullish: 48 percent expect business to improve this year, and just 8 percent anticipate lower sales. As for family-dining operators, 43 percent expect business to improve; 10 percent expect a sales decline. Although their top-line outlook is generally positive, fullservice operators aren't as bullish when it comes to the bottom line. About six of 10 operators in each of the three fullservice segments expect their profitability this year to be about the same or down from 2012.

INCOME CAPITALIZATION APPROACH

RENTALS MAP

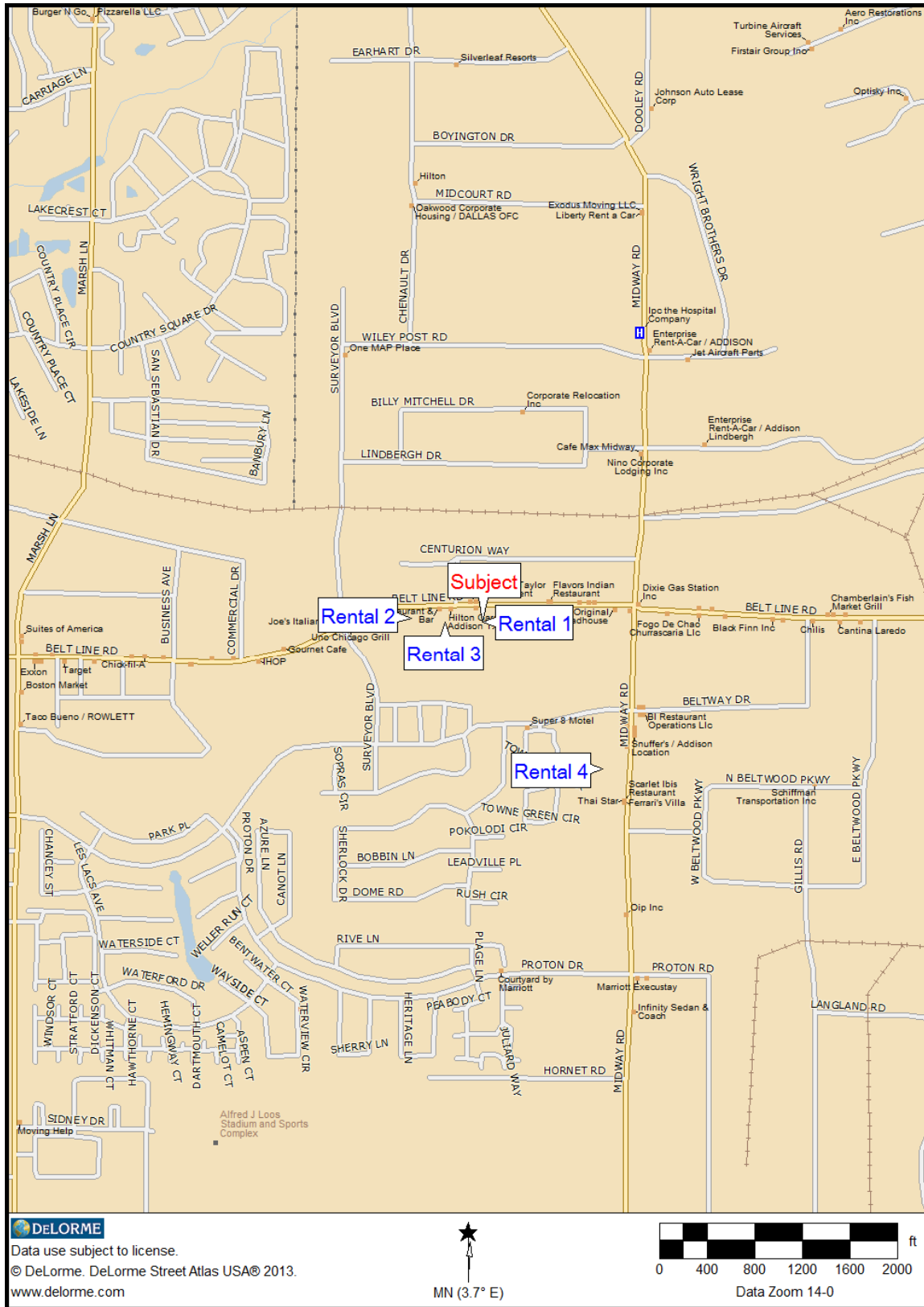

INCOME CAPITALIZATION APPROACH

RENTAL 1

Address	4080 Belt Line Road Addison, Dallas County, Texas
Mapsco	DA-14-B
Year of Construction	1993
Rentable Building Area	7,423 SF
Rental Rate Per SF	\$18.33
Lease Terms	Triple net; 5 year terms
Comments	This is the subject porperty

INCOME CAPITALIZATION APPROACH

RENTAL 2

Address	4050 Belt Line Road Addison, Dallas County, Texas
Mapsco	DA-14-B
Year of Construction	1988
Rentable Building Area	14,627 SF
Rental Rate Per SF	\$12.30
Lease Terms	Triple Net;
Comments	The property is located one restaurant west of the subject.

INCOME CAPITALIZATION APPROACH

RENTAL 3

Address	4060 Belt Line Road Addison, Dallas County, Texas
Mapsco	DA-14-B
Year of Construction	1992
Rentable Building Area	5,802 SF
Rental Rate Per SF	\$17.75
Lease Terms	Triple Net;
Comments	This is located directly west of the subject.

INCOME CAPITALIZATION APPROACH

RENTAL 4



Address	14831 Midway Road Addison, Dallas County, Texas
Mapsco	DA-14-B
Year of Construction	1980
Rentable Building Area	62,294 SF
Rental Rate Per SF	\$15.00
Lease Terms	Triple Net;
Comments	The property is a multi building shopping center. The agent recently leased three restaurant spaces ranging from three to seven thousand square feet for an average of \$15.00 per square foot. Triple net expense are around three dollars per square foot. Six months free rent was given.

INCOME CAPITALIZATION APPROACH

RENTAL SURVEY					
Rental No.	Name/Location	Rent/SF	Lease Basis	YOC	Rentable Area
1	4080 Belt Line Road Addison, Dallas County, Texas	\$18.33	Triple net	1993	7,423 SF
2	4050 Belt Line Road Addison, Dallas County, Texas	\$12.30	Triple Net	1988	14,627 SF
3	4060 Belt Line Road Addison, Dallas County, Texas	\$17.75	Triple Net	1992	5,802 SF
4	14831 Midway Road Addison, Dallas County, Texas	\$15.00	Triple Net	1980	62,294 SF

The properties in the survey are similar to the subject and are comparable in design, construction, and use. The facilities range in size from 5,802 square feet to 62,294 square feet. The lease rates of the survey range from \$12.30 to \$18.33 per square foot on a triple net basis, and are representative of market.

The subject concludes a lease agreement on a triple net lease basis. That is, the operator/tenant is responsible for operating expenses, including pro rata shares of taxes, insurance, and maintenance. Based on this lease arrangement, the only expense to an owner would be a management fee and any structural maintenance charges. Each of the comparable rents varies in quality and differs in size as compared with the subject.

Market Rent and Gross Rental Income Analysis

In estimating the appropriate market rental rate for the subject, all of the comparables were considered. Considering the location of the subject, the quality of finish, careful consideration of data and inspecting each comparable property, the data support a market rental rate of \$18.33 per square foot, on a triple net lease basis. This estimate recognizes the location, construction, size, quality, and condition of the subject as compared with competing properties in the local market.

Potential Gross Income

Based on the estimated market rate, the potential gross income of the subject property is \$116,412 per year, or \$18.33 per square foot.

Reimbursements

Under a triple net lease arrangement, the tenant is responsible for operating expenses. Reimbursements for taxes, insurance, and maintenance are estimated at \$27,127 for the restaurant, or \$4.27 per square foot.

INCOME CAPITALIZATION APPROACH

Vacancy & Collection Loss

According to the Dictionary of Real Estate Appraisal, vacancy and collection (credit) loss is defined as an allowance for reductions in potential income attributable to vacancies, tenant turnover, and non-payment of rent. The portion referring to vacancy is typically derived from market sources such as the market conditions of competing properties and the competitive market. The collection loss is a reflection of the type of tenants within the market or subject.

In order to estimate anticipated vacancy and credit loss for the subject, relevant market data sources have been researched, and the operating expenses and comparable properties have been analyzed.

Given the subject's size, current/potential tenancy, market occupancy rates, and location, a reasonable market vacancy and credit loss rate for the subject is estimated at 7%, which equates to \$10,048, or \$1.58 per square foot.

OPERATING EXPENSES

The following annual expense summary is estimated based on operations of similar properties in the subject market. Expenses include both fixed and variable expenses. Fixed expenses include ad valorem property taxes and property insurance. Variable expenses include management/administrative and maintenance/repair costs. Typical leases on properties of this type are structured on a triple net lease basis. That is, the operator/tenant is responsible for operating expenses, including pro rata shares of taxes, insurance, and maintenance. Based on this lease arrangement, the only expense to an owner would be a management fee and any structural maintenance charges.

Where actual operating statements were not available for analysis, estimates are applied in the expense estimates for the subject property.

EXPENSES

Real Estate Taxes

Real estate taxes (as detailed previously in the tax analysis portion of the subject property section) are estimated at \$16,927, or \$2.67 per square foot. This expense is reimbursed. The basis of this expense is the county appraisal district.

Fire & Extended Coverage Insurance

Based on information from third party reports, the estimated typical fire, extended coverage, and liability policy is \$3,000, or \$0.47 per square foot. This expense is reimbursed.

INCOME CAPITALIZATION APPROACH

Maintenance/Repairs

This category covers all normal annual maintenance and repair costs. This expense includes such items as interior repairs and grounds maintenance, as well as maintenance of the interior equipment, including HVAC units, elevators, plumbing and electrical. This expense includes such items as parking lot, security, trash, and landscaping. Based on information from third party reports, repairs and maintenance are estimated at \$7,200, or \$1.13 per square foot. This expense is reimbursed.

Management Fees

Includes general management, supervision, professional fees, legal fees, printing, keys and locks, sign expenses, and purchasing, etc. Management fees in this market range between 3% and 8% of effective gross income. Based on the market estimates and data, we utilize a 3% management fee based on market estimates, which equates to \$4,005 (\$0.63 per square foot).

Reserves

Reserves are an appropriation from the income of the real estate that is allocated to deferred or anticipated contingencies, such as structural maintenance. This expense is estimated at \$1,200, or \$0.19 per square foot.

Utilities

The utilities are paid directly to the service provider by the tenant and are not included in this pro forma analysis.

INCOME CAPITALIZATION APPROACH

Expense Summary

Based on the foregoing, the expenses are estimated at \$5.09 per square foot, or \$32,332 per year.

The following table is the stabilized pro forma operating statement for the subject property.

INCOME AND EXPENSE SUMMARY			
Rentable Building Area: 6,351 SF			
		Total	\$/SF
Gross Rental Income		\$ 116,412	\$ 18.33
Expense Reimbursements		\$ 27,127	\$ 4.27
Total Potential Income		\$ 143,539	\$ 22.60
Less: Vacancy @ 7%		\$ 10,048	\$ 1.58
Effective Gross Income		\$ 133,491	\$ 21.02
<u>Less: Expenses</u>	<u>Reimbursed</u>		
Real Estate Taxes	X	\$ 16,927	\$ 2.67
Insurance	X	\$ 3,000	\$ 0.47
Maintenance/Repairs	X	\$ 7,200	\$ 1.13
Management Fees (3% of EGI)		\$ 4,005	\$ 0.63
Structural Maintenance/Reserves		\$ 1,200	\$ 0.19
Total Expenses		\$ 32,332	\$ 5.09
Net Operating Income		\$ 101,159	\$ 15.93

INCOME CAPITALIZATION APPROACH

CAPITALIZATION

In the sales comparison approach, the pro-forma data indicate overall capitalization rates ranging from 6.6% to 11.6%.

Summary of Improved Sales		
Sale No.	Name/Location	OAR
1	17795 Dallas Parkway	9.2%
2	17548 Dallas Parkway	6.6%
3	18438 Dallas Parkway	11.6%

The overall rate developed by the band of investment method is based on (1) the capitalization rate for debt, called the mortgage constant, and (2) the rate of return required on equity, called the equity capitalization rate. For the subject, a 25-year amortization period is used covering 75% of the value at 6.00% interest, and considering the characteristics of the subject, an equity return of 9.00%. Using the band of investment method, the overall rate is developed as follows:

Amortization Period	25 years	Mortgage Constant (Rm)	-0.077316
Loan-to-Value Ratio	75%		
Equity Component	25%		
Interest Rate (i)	6.00%		
Equity Dividend Rate (Re)	9.00%		
	<u>% Total Value</u>	<u>Return Required</u>	
Loan	0.750	x	0.07732 (mortgage constant) = 0.05799
Equity	0.250	x	0.09000 (equity dividend rate) = 0.02250
			Overall Rate <u>0.08049</u>
			Rounded 8.04%

Secondary data sources are noted regarding overall rates. Real Estate Research Corporation (RERC) conducts a quarterly survey of major knowledgeable real estate participants. This survey tracks target rates of return (discount rates) and capitalization rates for predominately investment-grade properties. The specific criteria for industrial warehouse properties are most applicable to the subject. The RERC survey indicates a going-in capitalization rate of 7.9%, for predominately neighborhood commercial properties.

INCOME CAPITALIZATION APPROACH

DALLAS/FT. WORTH

4TH QUARTER 2013

Dallas/Ft. Worth Investment Criteria First-Tier ¹ Investment Properties													
	Pre-Tax Yield (%)			Going-In Cap Rate (%)			Terminal Cap Rate (%)			Anticipated 1-Year Growth Rates			
	RERC Estimate	South Region	U.S.	RERC Estimate	South Region	U.S.	RERC Estimate	South Region	U.S.	National Value	South Value	National Rent	South Rent
Offc - CBD	8.7	9.1	8.7	7.0	7.6	7.2	7.8	8.3	7.9	2.3	2.3	2.1	2.0
Offc - Suburban	9.1	9.4	9.4	7.5	7.8	7.7	8.3	8.5	8.4	1.9	2.2	1.8	1.9
Ind - Warehouse	8.7	9.2	9.0	7.1	7.7	7.5	7.8	8.3	8.1	2.6	2.9	2.4	2.6
Ind - R&D	9.3	9.4	9.3	7.8	8.1	7.9	8.4	8.7	8.5	2.1	2.2	1.9	1.8
Ind - Flex	9.4	9.5	9.4	7.9	8.2	8.0	8.5	8.7	8.5	2.1	2.1	1.9	1.7
Ret - Reg Mall	8.5	9.1	8.9	6.9	7.6	7.4	7.6	8.2	8.1	1.9	1.9	1.7	1.7
Ret - Pwr Center	8.9	9.1	9.0	7.4	7.7	7.5	8.1	8.3	8.2	2.2	2.4	2.0	2.1
Ret - Neigh/Comm.	8.9	9.4	9.1	7.4	7.9	7.7	8.0	8.6	8.3	2.2	2.7	2.0	2.2
Apartment	7.8	8.2	8.0	6.0	6.5	6.2	6.7	7.2	6.9	3.3	3.4	3.1	3.1
Hotel	10.0	10.0	10.0	8.0	8.3	8.3	8.8	9.0	9.0	2.7	3.7	2.6	3.4
Average	8.9	9.2	9.1	7.3	7.7	7.5	8.0	8.4	8.2	2.3	2.6	2.2	2.3

¹ First-tier investment properties are defined as new or newer quality construction in prime to good locations.
Source: RERC Investment Survey.

In addition to the RERC survey, the Realtyrates.com Market Survey shows average operating data and investment data. The Realtyrates.com survey indicates target rates in the range of 5.62% to 10.69%.

RealtyRates.com INVESTOR SURVEY - 4th Quarter 2013*						
RETAIL - UN-ANCHORED CENTERS						
Item	Input					OAR
Minimum						
Spread Over 10-Year Treasury	0.95%	DCR Technique	1.30	0.050925	0.75	4.97
Debt Coverage Ratio	1.30	Band of Investment Technique				
Interest Rate	3.69%	Mortgage	75%	0.050925	0.038194	
Amortization	35	Equity	25%	0.083647	0.020912	
Mortgage Constant	0.050925	OAR				5.91
Loan-to-Value Ratio	75%	Surveyed Rates				5.62
Equity Dividend Rate	8.36%					
Maximum						
Spread Over 10-Year Treasury	5.79%	DCR Technique	2.25	0.118380	0.50	13.32
Debt Coverage Ratio	2.25	Band of Investment Technique				
Interest Rate	8.53%	Mortgage	50%	0.118380	0.059190	
Amortization	15	Equity	50%	0.183347	0.091674	
Mortgage Constant	0.118380	OAR				15.09
Loan-to-Value Ratio	50%	Survey				14.33
Equity Dividend Rate	18.33%					
Average						
Spread Over 10-Year Treasury	3.37%	DCR Technique	1.78	0.078125	0.63	8.67
Debt Coverage Ratio	1.78	Band of Investment Technique				
Interest Rate	6.11%	Mortgage	63%	0.078125	0.048828	
Amortization	25	Equity	38%	0.128512	0.048192	
Mortgage Constant	0.078125	OAR				9.70
Loan-to-Value Ratio	63%	Surveyed Rates				10.69
Equity Dividend Rate	12.85%					

*3rd Quarter 2013 Data

Copyright 2013 RealtyRates.com™

INCOME CAPITALIZATION APPROACH

An overall capitalization rate of 7.50% is supported for the subject. The net operating income is capitalized using an overall rate of 7.50%, and results in a value indication of \$1,348,787 ($\$101,159 \div 0.0750$). Based on the foregoing, the income capitalization approach supports a market value of \$1,348,787.

Net Operating Income	=	\$101,159
Capitalization Rate		0.0750
Value Indicated By Direct Capitalization		\$1,348,787

RECONCILIATION – WHOLE PROPERTY VALUE

In the preceding sections of this report, the area data and trends, location amenities, highest and best use, and other elements of value are discussed. The market was researched for comparable data and market trends.

In the final analysis, considering the approaches to value, each approach is analyzed in terms of the quantity and quality of the data used in each approach and applicability to estimating a reliable value.

Summary of Approaches

Cost Approach	\$1,512,125
Sales Comparison Approach	\$1,429,000
Income Capitalization Approach	\$1,348,787

Sufficient sales of tracts of land with similar utility are available to arrive at an opinion of value of the land by market comparison. The sales used are adjusted to reflect current market conditions and differences in physical characteristics.

Land Value at \$20.00 per square foot	\$1,316,150
--	--------------------

Cost Approach

The estimated costs are compared with the Marshall Valuation Service Cost Manual. Additionally, a review of cost manuals, conversations with local building contractors and developers, and the appraiser's experience in valuing similar properties readily support these costs.

The cost approach is most applicable when a property is new or proposed and when the development represents the highest and best use of the site. The age of the improvements is estimated at 21 years. Overall, the cost approach is a supporting valuation method for this analysis.

Sales Comparison Approach

The price per square foot is used in the sales comparison approach to provide an indication of value for the subject. These transactions are considered to reflect the behavior of typical market participants. Although the sales were somewhat different in age, size, and use, they provide reasonable value indications of the subject, after adjustment for these various differences. The value range produced by this approach is a reasonable indicator based on the best available market data.

Income Capitalization Approach

The direct capitalization method is used in the income capitalization approach to develop an indication of market value. Operating expenses are estimated based primarily on actual data from other projects, subject historical records (if available), and data extracted from the tax rolls.

The income capitalization approach is the best approach to determine market value when the real estate market recognizes the value of a property based on the income it produces. The comparables used are representative of market and provided a good indicator of the potential of the subject property.

RECONCILIATION – WHOLE PROPERTY VALUE

CONCLUSION

In conclusion, the cost approach is a supporting valuation approach, due to the age of the improvements, which represent the highest and best use of the site. The sales comparison and income capitalization approaches are the most reliable indicators due to both the quality and quantity of the available sale data and current rental market data, and provide a good basis for valuation. Based on the above considerations for the subject property, our final opinion of the market value of the subject in the whole property condition is as follows:

Whole Property (Market Value) \$1,400,000

REMAINDER BEFORE TAKING

Part To Be Acquired

The part to be acquired in **fee simple** is a triangularly shaped parcel comprising 0.018 acres, or 783 square feet, stated. The length of the acquisition area is 57.90 feet along the northwest property corner with lengths of 34.51 feet along the northern boundary along Belt Line Road and 41.27 feet along the western boundary along Runyon Road. The proposed fee simple acquisition amounts to approximately 1.18 percent of the land area (783 SF ÷ 66,184 SF = 0.0118). The fee simple acquisition is partially located within an existing twenty-foot drainage and utility easement and includes a sign easement. The acquisition area will be used for sidewalks and landscaping.

Also situated in and/or proximate to the acquisition area are utility lines and appurtenances, such as utility equipment, signs, and markers. These items are assumed the property of others-unrelated entities of subject ownership. It is assumed that the town of Addison will negotiate the successful movement of these items where necessary, and without burden to the subject owner.

Landowner improvements situated in the proposed acquisition areas include irrigation and landscaping. Landscaping is comprised of ornamental grass. Items that appear to be the property of others (other than the subject owner) are not considered in the valuation of the subject.

A portion of the acquisition area is located within Runyon Road and includes curbing and concrete paving. Runyon Road at the subject is an access easement recorded in Volume 92009, Page 3611. The access road was installed and is maintained by Wal-Mart, as such, these improvements are excluded from the compensation, and we assume the Town will negotiate with Wal-Mart for agreeable resolution for these improvements.

Within the acquisition area is a sign easement benefitting the southern abutting Hilton Garden Inn. The easement area is improved with a monument sign that is fully within the part to be acquired. The Town of Addison has indicated that the sign will be allowed to stay within the acquisition area. We assume that the town will grant easement rights to Equinox Hotel Addison, LLC. The monument sign is excluded from the appraisal.

Improvements Located in Acquisition Area - Fee Simple	
Parcel 38R - Belt Line Road Project	
Addison, Dallas County Texas	
<u>Improvements</u>	<u>Quantity</u>
Irrigation	653 SF
Landscaping	653 SF

Highest and Best Use

The part to be acquired is small parcel and could not be developed as a separate property. The highest and best use is as part of the whole property.

REMAINDER BEFORE TAKING

PARCEL 38R
 0.0180 ACRE (783 SQUARE FEET)
 RIGHT OF WAY
 OUT OF
 LOT 1 OF
 AMENDED FINAL PLAT OF BELT LINE CENTER
 TOWN OF ADDISON, DALLAS COUNTY, TEXAS

BEING a 783 square foot tract of land situated in the T. L. Chenoweth Survey, Abstract Number 273, Town of Addison, Dallas County, Texas, being part of Lot 1, Block 1 of AMENDED FINAL PLAT OF BELT LINE CENTRE, an addition to the Town of Addison, Texas, as recorded in Volume 92193, Page 1795 of the Deed Records, Dallas County, Texas (D.R.D.C.T.), also being part of that tract of land described in deed to 4080 BLR, LTD, as recorded in Instrument Number 201000247792 of the Official Public Records of Dallas County, Texas, and being more particularly described as follows:

BEGINNING at a point for corner at the intersection of the north line of said Lot 1 with the east line of an Access Easement recorded in Volume 92009, Page 3611 ,D.R.D.C.T., said corner also being on the south right-of-way line of Belt Line Road (a variable width right-of-way);

THENCE North 89 degrees 53 minutes 27 seconds East, with said north line of Lot 1 and said south right-of-way line of Belt Line Road, a distance of 34.51 feet to a point for corner (unable to set);

THENCE South 47 degrees 16 minutes 28 seconds West, departing said south right-of-way line of Belt Line Road and said north line of Lot 1, a distance of 57.90 feet to a set PK Nail with shiner for corner on said east line of said Access Easement;

THENCE North 00 degrees 06 minutes 33 seconds West, with said east line of said Access Easement, a distance of 18.70 feet to a point for corner at the beginning of a tangent circular curve to the right having a radius of 30.00 feet, whose chord bears North 21 degrees 26 minutes 35 seconds East, a distance of 22.04 feet;

THENCE Northerly, continuing with said east line of said Access Easement and with said curve, through a central angle of 43 degrees 06 minutes 17 seconds, an arc distance of 22.57 feet to the POINT OF BEGINNING and containing 0.0180 of an acre (783 square feet) of land, more or less.

NOTES:

The basis of bearing is the Town of Addison Survey Control Network (December 2007 update) based on Monument Numbers COA-3, COA-4, COA-5, COA-10, & COA-11. All distance are surface distances using the TXDOT Dallas County Scale Factor 1.000136506.

A survey exhibit of even date accompanies this metes & bounds description.



Page 1 of 3

I:\29000s\29350\Admin\Documents\Survey\LD_PARCEL 38R.docx

REMAINDER BEFORE TAKING

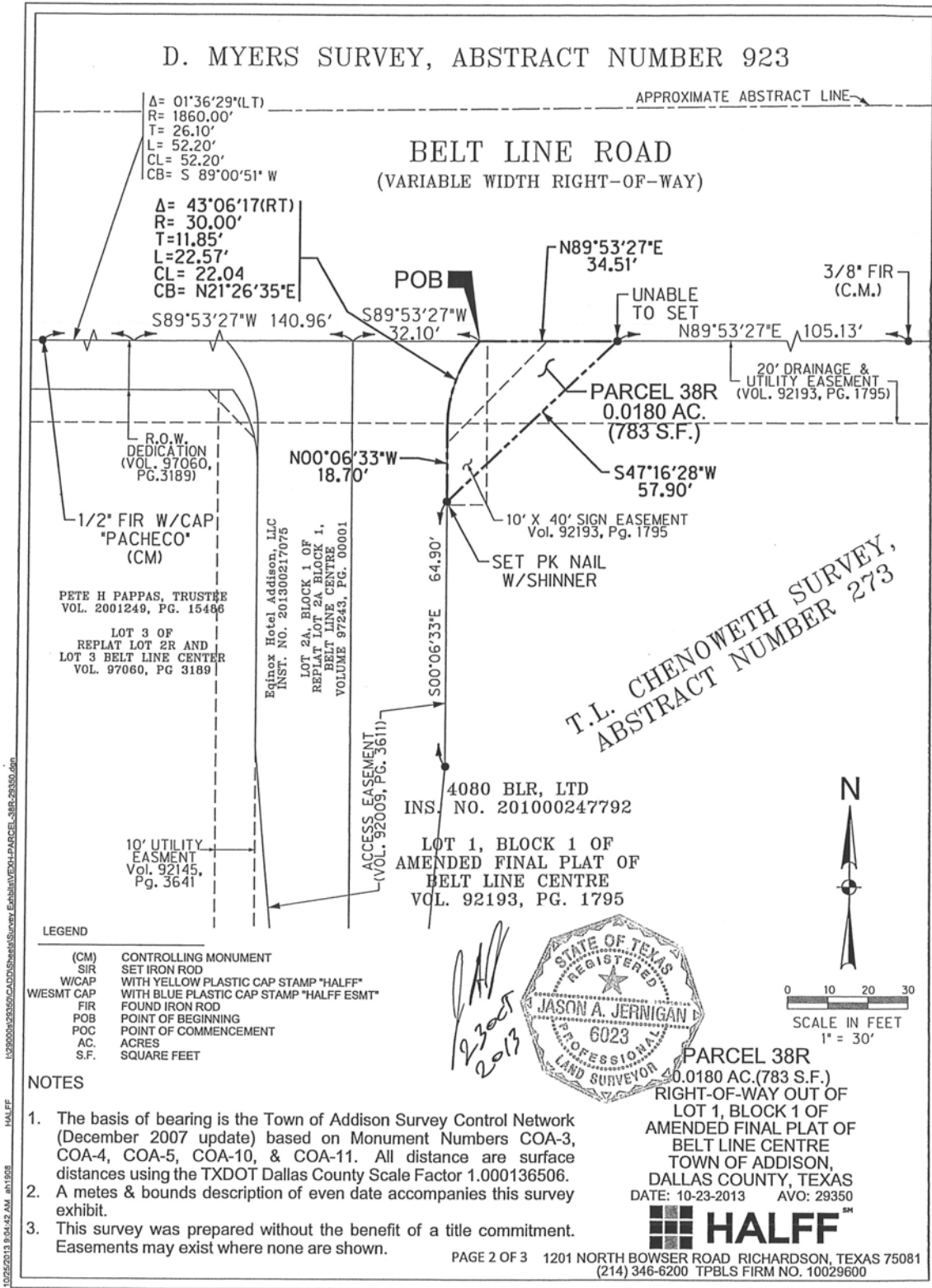

1/2025/2013 8:54:42 AM JALFF HALFF 1/2025/2013 8:54:42 AM JALFF HALFF

LEGEND

(CM)	CONTROLLING MONUMENT
SIR	SET IRON ROD
W/CAP	WITH YELLOW PLASTIC CAP STAMP "HALFF"
W/ESMT CAP	WITH BLUE PLASTIC CAP STAMP "HALFF ESMT"
FIR	FOUND IRON ROD
POB	POINT OF BEGINNING
POC	POINT OF COMMENCEMENT
A.C.	ACRES
S.F.	SQUARE FEET

NOTES

1. The basis of bearing is the Town of Addison Survey Control Network (December 2007 update) based on Monument Numbers COA-3, COA-4, COA-5, COA-10, & COA-11. All distance are surface distances using the TXDOT Dallas County Scale Factor 1.000136506.
2. A metes & bounds description of even date accompanies this survey exhibit.
3. This survey was prepared without the benefit of a title commitment. Easements may exist where none are shown.



PARCEL 38R
 0.0180 AC. (783 S.F.)
 RIGHT-OF-WAY OUT OF
 LOT 1, BLOCK 1 OF
 AMENDED FINAL PLAT OF
 BELT LINE CENTRE
 TOWN OF ADDISON,
 DALLAS COUNTY, TEXAS
 DATE: 10-23-2013 AVO: 29350



REMAINDER BEFORE TAKING

Compensation

The take line extends through land that includes landowner improvements. The compensation due the property owner for the part taken is comprised of land value plus the depreciated value of the improvements acquired.

Valuation of the Fee Simple Acquisition

The land value of the whole property is previously established at \$20.00 per square foot. The part to be acquired in fee simple is valued at \$8,130 for the land.

Calculation:

No. of SF	x	\$/SF	=	Indicated Value
281	x	\$20.00	=	\$5,620
502	x	\$20.00 x 25%	=	\$2,510
783				\$8,130

The improvements situated in the acquisition parcel are valued at \$1,285.

Improvements (within the acquisition area)	Value
653 SF - Irrigation @ \$1.15/SF, less 42% depreciation	\$ 436
653 SF - Landscaping @ \$1.30/SF, no depreciation	\$ 849
Total Contributory Value of Improvements	\$ 1,285

The total value of the part to be acquired in fee simple, including land and improvements is \$9,415.

REMAINDER BEFORE TAKING

Remainder Before Taking

The indicated value of the remainder before the taking is derived by deducting the value of the take from the value of the whole property. The calculation is as follows:

Opinion of value - whole property	\$ 1,400,000
Opinion of value - taking	\$ 9,415
Opinion of value - remainder before the taking	<u>\$ 1,390,585</u>

REMAINDER AFTER TAKING

Remainder After Taking

The remainder after taking is valued by a separate analysis of the property addressing physical characteristics, highest and best use, utility, and marketability.

The remainder comprises 1.501 acres, or 65,401 square feet, calculated.

Remainder After The Acquisition As Affected By The Fee Simple Taking

After the taking, no building improvements are removed. The access remains via one curb cut along the eastern line of Runyon Road, at proportionately the same location as the whole property. In the whole property condition, the distance is approximately 34 feet from the building to the existing right of way along Belt Line Road and approximately 17 feet to Runyon Road. In the remainder after, the new right-of-way line is approximately 6.7 feet from the northwest restaurant corner. The acquisition area will be used for landscaping and sidewalks. Damages to the remainder are not indicated, as the acquisition a parcel and its use in the project will not interfere with the use of the subject property.

The remainder property is appraised as though the elevation and grade of the land at the new right-of-way line is substantially similar to the whole property condition with respect to the existing right-of-way line.

As if complete and in place, the road project improvements are a general enhancement in the neighborhood and are not judged to enhance a specific property.

Highest & Best Use

The improvements were built in 1993, according to the Dallas County Appraisal District. The improvements are of average quality and in average condition. The intended use of the improvements is for restaurant use. The physical characteristics and accompanying amenities support the continued use as such. The site is zoned PD, Planned Development by the town of Addison. Restaurants are allowed in this zoning district. The existing improvements have an effective age of approximately 21 years, with a remaining economic life estimated at 14 years. No other use of the improvements could provide a greater return in the current market. As improved, the property is a restaurant and is suitable for restaurant use. Therefore, the continued use as a restaurant represents the highest and best use of the land and improvements.

REMAINDER AFTER TAKING

Remainder After Value

The remainder property is valued using the methodologies from the whole property condition and the same land sales, improved sales, and comparable rents.

The remainder after the taking is the same as the whole property, but with a small area encumbered by the easement. The remainder land area is 65,401 square feet, or 1.501 acres. The highest and best use of the remainder property continues as restaurant use.

Reference the following summary of the valuation approaches in the remainder after.

Summary of Approaches – Remainder After

Cost Approach	\$1,502,710
Sales Comparison Approach	\$1,429,000
Income Capitalization Approach	\$1,348,787

The data do not support damages to the remainder. The indicated value of the remainder property is **\$1,390,585**.

As if complete and in place, the road project improvements are a general enhancement in the neighborhood and are not judged to enhance a specific property.

SUMMARY OF COMPENSATION

SUMMARY OF COMPENSATION

The proposed taking does not bisect the remainder. In the remainder after scenario, the highest and best use of the property is for continued use as a restaurant property. Access remains at proportionately the same location as before the acquisition.

The total compensation consists of the value of the part taken in fee simple. Damages to the remainder are not supported. Cost to cure are not necessary.

Total Compensation

The market value of the total compensation due to the landowner is \$9,415.

Whole Property (Market Value)	\$	1,400,000	
Part To Be Acquired in Fee Simple			\$ 9,415
Remainder - Before Taking	\$	1,390,585	
Remainder - After Taking	\$	1,390,585	
Costs-to-Cure			\$ 0
Total Compensation			\$ 9,415

APPRAISER'S CERTIFICATE

The undersigned do hereby certify that, except as otherwise noted in this appraisal report:

We have no present or contemplated future interest in the real estate that is the subject of this appraisal report. We have no personal interest or bias with respect to the subject matter of this appraisal report or the parties involved. Our engagement in this assignment was not contingent upon developing or reporting predetermined results. Our compensation for completing this assignment is not contingent upon the development or reporting of a predetermined value or direction in value that favors the cause of the client, the amount of the value opinion, the attainment of a stipulated result, or the occurrence of a subsequent event directly related to the intended use of this appraisal.

To the best of our knowledge and belief, the statements of fact contained in this appraisal report, upon which analyses, opinions and conclusions expressed herein are based, are true and correct.

This appraisal report sets forth all of the assumptions and limiting conditions (imposed by the terms of our assignment or by the undersigned) affecting the analyses, opinions, and conclusions contained in this report. These are our personal, impartial, unbiased professional analyses, opinions, and conclusions.

This appraisal report has been made in conformity with the Uniform Standards of Professional Appraisal Practice. We certify that, to the best of my knowledge and belief, the reported analyses, opinions, and conclusions were developed, and this report has been prepared, in conformity with the requirements of the Code of Professional Ethics and the Standards of Professional Practice of the Appraisal Institute and in conformity with the rules of the Texas Real Estate Commission. The use of this report is subject to the requirements of the Appraisal Institute relating to review by its duly authorized representatives.

The Appraisal Institute conducts a program of continuing education for its designated members. As of the date of this report, Charles Stearman has completed the Standards and Ethics Education Requirements for Candidates of the Appraisal Institute..

We have not appraised or provided a real estate service for this property within the last three years. Jace Whatley and Wendell Pyles provided real property appraisal assistance to the person signing this certification. We certify that we personally inspected the property appraised.

PYLES ★ WHATLEY CORPORATION



Charles Stearman, SR/WA
State of Texas Certification #TX-1335388-G

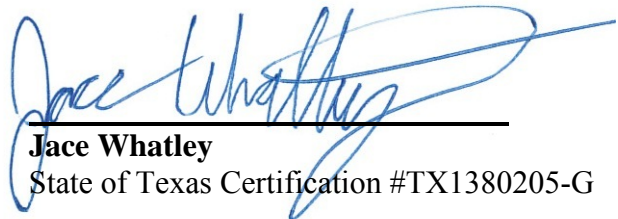

Jace Whatley
State of Texas Certification #TX1380205-G

QUALIFICATIONS

CHARLES STEARMAN

Appraisal assignments include retail properties, office buildings, and industrial properties, automobile dealerships, convenience stores, restaurants, religious facilities, land development, and specialized properties, single- and multi-family dwellings, sales studies, right-of-way acquisitions, access rights, surplus property, easements, and condemnation work.

Experience

- Engaged in appraisal work since 1998
- Real estate broker specializing in single-family sales, leasing, and property management
- President and co-owner of Maverick Management, Inc., Arlington, Texas. Responsible for policy and procedure implementation, contract review, leasing and management of single-family residences (1995 – 1998).
- Director, Property Management & Leasing, Van Zandt, REALTORS, Arlington, Texas. Developed and implemented department policies and procedures, oversight of department staff, agents and operations, advising company clients, sales, leasing and management (1992 – 1995).
- Instructor, approved by the Texas Real Estate Commission, George Leonard School of Real Estate, Arlington, Texas. Instructed students in courses requisite to real estate licensure 1995-1999.
- Accepted as an expert witness in condemnation proceedings

Education

- Texas A&M University
- Abilene Christian University
- Tarrant County College
- International Right-of-Way Association
- Appraisal Institute

Candidacy

- Candidate for Designation, Appraisal Institute

Professional

- State of Texas – State Certified General Real Estate Appraiser, No. TX-1335388-G
 - Approved Appraiser – Texas Department of Transportation
 - State of Texas – Licensed Real Estate Broker, No. 0363379
 - SR/WA Designation, No. 6050, Senior Member, International Right of Way Association
 - IRWA Chapter 36: Education Chair-2008, Secretary-2009, Treasurer-2010, Vice President-2011, President-2012, Director-2013
 - Member, Lewisville Association of REALTORS, Waco Association of REALTORS, Texas, and National Association of REALTORS
-

JACE C. WHATLEY**Experience**

- ❖ Employed with PYLES WHATLEY CORPORATION. Appraisal assignments include retail centers, restaurants, convenience stores, office buildings, and various commercial and industrial properties. Additional consulting assignments include condemnation and right-of-way work.

Education

- ❖ North Texas Chapter of the Appraisal Institute
 - Appraisal Principles
 - Appraisal Procedures
 - National USPAP
 - Site Valuation and Cost Approach
 - Sales Comparison Approach
 - Real Estate Statistics
 - Market Analysis and Highest and Best Use
 - Basic Income Approach Part 1
 - Basic Income Approach Part 2
 - General Report Writing and Case Studies
 - Advanced Income Capitalization
- ❖ University of Texas at Austin, 2004-2008
 - McCombs School of Business: Bachelor of Business Administration
 - Major: Finance, Minor: Accounting

Professional Titles

- ❖ Texas Appraiser Licensing and Certification Board
 - Certified General Real Estate Appraiser, State of Texas Authorization # 1380205-G
 - ❖ Appraisal Institute
 - Candidate for Designation
 - Passing score on the MAI Comprehensive Examination
 - ❖ IRWA Chapter 36: Program Chair, August 2012
-

ADDENDA

TAX CARDS



[Home](#) | [Find Property](#) | [Contact Us](#)

Commercial Account #10002400010010000

[Location](#) [Owner](#) [Legal Desc](#) [Value](#) [Improvements](#) [Land](#) [Exemptions](#) [Estimated Taxes](#) [Building Footprint](#) [History](#)

Location (Current 2014)

Address: 4080 BELT LINE RD
Market Area: 0
Mapsc0: 14-B (DALLAS)

Customer Service Survey

Enter PIN:

DCAD Property Map

[View Photo](#)

2013 Appraisal Notice

Electronic Documents (ENS)

[Print Homestead Exemption Form](#)



Owner (Current 2014)

4080 BLR LTD
 4311 W LOVERS LN STE 200
 DALLAS, TEXAS 752092803

Multi-Owner (Current 2014)

Owner Name	Ownership %
4080 BLR LTD	100%

Legal Desc (Current 2014)

1: BELT LINE CENTRE
 2: BLK 1 LT 1 ACS 1.5194
 3:
 4: INT201000247792 DD09242010 CO-DC
 5: 0024000100100 31000240001
Deed Transfer Date: 9/27/2010

Value

2013 Certified Values	
Improvement:	\$13,160
Land:	+ \$661,840
Market Value:	= \$675,000
Tax Agent: SLJ COMPANY LLC	
Revaluation Year:	2012
Previous Revaluation Year:	2011

Improvements (Current 2014)

#	Desc: THEME RESTAURANT	Total Area: 7,423 sqft	Year Built: 1993
1	Construction Construction: D-WOOD FRAME CONCRETE SLAB Foundation (Area): (7,423 sqft) Net Lease Area : 7,423 sqft # Stories: 1 # Units: 0 Basement (Area): NONE Heat: CENTRAL HEAT A/C: CENTRAL A/C	Depreciation Physical: 37% Functional: + 0% External: + 0% Total: = 57% Quality: GOOD Condition: GOOD	Appraisal Method INCOME

Land (2013 Certified Values)

#	State Code	Zoning	Frontage (ft)	Depth (ft)	Area	Pricing Method	Unit Price	Market Adjustment	Adjusted Price	Ag Land
1	COMMERCIAL IMPROVEMENTS	PLANNED DEVELOPMENT	0	0	66,184.0000 SQUARE FEET	STANDARD	\$10.00	0%	\$661,840	N

* All Exemption information reflects 2013 Certified Values. *

Exemptions (2013 Certified Values)

No Exemptions

Estimated Taxes (2013 Certified Values)

	City	School	County and School Equalization	College	Hospital	Special District
Taxing Jurisdiction	ADDISON	DALLAS ISD	DALLAS COUNTY	DALLAS CO COMMUNITY COLLEGE	PARKLAND HOSPITAL	UNASSIGNED
Tax Rate per \$100	\$0.5718	\$1.282085	\$0.2531	\$0.1247	\$0.276	N/A
Taxable Value	\$675,000	\$675,000	\$675,000	\$675,000	\$675,000	\$0
Estimated Taxes	\$3,859.65	\$8,654.07	\$1,708.43	\$841.73	\$1,863.00	N/A
Tax Ceiling					N/A	N/A
Total Estimated Taxes:						\$16,926.87

DO NOT PAY TAXES BASED ON THESE ESTIMATED TAXES. You will receive an **official tax bill** from the appropriate agency when they are prepared. Taxes are collected by the agency sending you the **official** tax bill. To see a listing of agencies that collect taxes for your property. [Click Here](#)

The estimated taxes are provided as a courtesy and should not be relied upon in making financial or other decisions. The Dallas Central Appraisal District (DCAD) does not control the tax rate nor the amount of the taxes, as that is the responsibility of each Taxing Jurisdiction. Questions about your taxes should be directed to the appropriate taxing jurisdiction. We cannot assist you in these matters. These tax estimates are calculated by using the most current certified taxable value multiplied by the most current tax rate. **It does not take into account other special or unique tax scenarios.** If you wish to calculate taxes yourself, you may use the [TaxEstimator](#) to assist you.

Building Footprint (Current 2014)

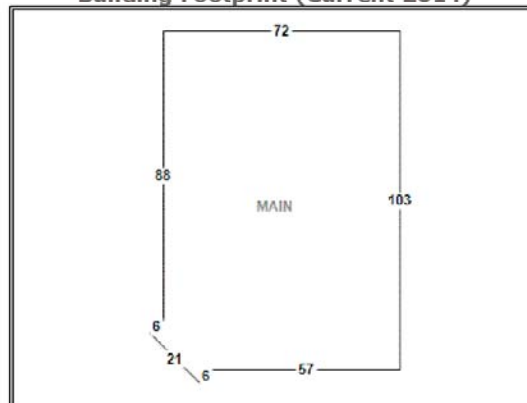

History

PYLES★WHATLEY CORPORATION
Real Estate Consultants

Wendell Pyles, MAI, SR/WA

Jan Whatley (1953-2013)

January 02, 2014

4080 BLR LTD
4311 W Lovers Lane, Ste 200
Dallas, Texas 75209-2803

Via first class, certified mail, return receipt requested, article no. 7012 3050 0001 4153 2255

Re: Parcel 38R - real estate property located at 4080 Belt Line Road, Addison, Texas

To Whom It May Concern:

In connection with the Town of Addison, our firm has been engaged to perform a real estate appraisal of a proposed partial acquisition involving the property referenced above. In preparation for the Belt Line Road Project, real estate appraisals of the affected properties are required.

We would like to meet with you and inspect your property for appraisal purposes. Please contact **Jace Whatley** at **214.340.5880** to arrange an appointment.

Enclosed are copies of the acquisition descriptions and drawings. We look forward to meeting you.

Sincerely,

PYLES WHATLEY CORPORATION

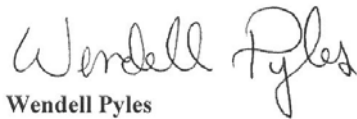

Wendell Pyles

11551 Forest Central Drive
Suite 220
Dallas, Texas 75243

Phone (214) 340-5880
Fax (214) 340-5422

www.PylesWhatley.com

Toll Free (800) 340-2166

777 Main Street
Suite 600
Fort Worth, Texas 76102

Phone (817) 887-8176
Fax (817) 887-8177

7012 3050 0001 4153 2555

U.S. Postal Service™
CERTIFIED MAIL™ RECEIPT
(Domestic Mail Only; No Insurance Coverage Provided)

For delivery information visit our website at www.usps.com

OFFICIAL USE

Postage	\$	0.46	
Certified Fee		3.10	
Return Receipt Fee (Endorsement Required)		2.55	
Restricted Delivery Fee (Endorsement Required)			
Total Postage & Fees	\$	6.11	

Sent To
 Street, Apt. or PO Box
 City, State

4080 BLR Ltd ↓
 4311 W. Lovers Lane, Ste 200
 Dallas, TX 75209-2803
 13-665 / JCW

PS Form 3800, April 2010