



SPECIFICATIONS AND CONTRACT DOCUMENTS

FOR THE CONSTRUCTION OF

WINNWOOD POND DREDGING PROJECT

BID NUMBER 16-92

**TOWN OF ADDISON, TEXAS
INFRASTRUCTURE & DEVELOPMENT SERVICES**

MAY 2016

PREPARED BY



**12225 Greenville Avenue, Suite 200
Dallas, Texas 75243
(214) 572-2272
Fax (214) 739-0095**



TOWN OF ADDISON, TEXAS

MAYOR

Todd Meier

COUNCILMEMBERS

Janelle Moore

David Heape

Bruce Arfsten

Mary Carpenter

Ivan Hughes

Dale Wilcox

CITY MANAGER

Wesley S. Pierson

DIRECTOR OF INFRASTRUCTURE & DEVELOPMENT SERVICES

Lisa Pyles

DEPUTY CITY MANAGER

Cheryl Delaney

TABLE OF CONTENTS

Section AB	Advertisement for Bids
Section IB	Instructions to Bidders
Section PF	Proposal Form
Section PQ	Prequalification Statement
Section BB	Bid Bond
Section CI	Indemnification Agreement
Section CA	Contract Agreement
Section PrB	Performance Bond
Section PyB	Payment Bond
Section MB	Maintenance Bond
Section BP	Contractor's Affidavit of Bills Paid
Section GP	General Provisions <i>Standard Specifications for Public Works Construction – North Central Texas</i>
Section SP	Special Provisions
Section PS	Project Sign
Section TS	Technical Specifications
Attachment A	Environmental Investigation
Attachment B	Section 404 – Letter of Permission <i>1. Application</i> <i>2. Letter of Permission</i>
Attachment C	Record Drawings – Creek System Improvements 1989

SECTION AB

ADVERTISEMENT FOR BIDS

ADVERTISEMENT FOR BIDS

1. Sealed bids addressed to the Town of Addison, Texas, for the **Winnwood Pond Dredging Project** in the Town of Addison, Texas, hereinafter called "City" or "Owner" in accordance with specifications and contract documents prepared by **Halff Associates, Inc.** will be received at the office of Wil Newcomer, Purchasing Manager, Finance Building, 5350 Belt Line Road, Addison, Texas until **2:00 p.m. on Tuesday, May 24, 2016**. Bids received by the appointed time will be opened and read aloud. Any bids received after closing time will be returned unopened.
2. The Contractor shall identify his bid on the outside of the envelope by writing the words **INFRASTRUCTURE & DEVELOPMENT SERVICES BID NUMBER 16-92, WINNWOOD POND DREDGING PROJECT**.
3. Bids shall be accompanied by a cashier's check or certified check upon a national or state bank in an amount not less than five percent (5%) of the total maximum bid price payable without recourse to the Town of Addison, or a bid bond in the same amount from a reliable surety company licensed by the State of Texas to act as a Surety and be listed on the current U.S. Treasury Listing of Approved Sureties, or a Binder of Insurance executed by a surety company licensed by the State of Texas to act as a surety or its authorized agent as a guarantee that the bidder will enter into a contract and execute a Performance Bond within ten (10) days after notice of award of contract to him.
4. Plans, specifications and bidding documents may be downloaded from www.bidsync.com. The Town of Addison is a "free buyer", meaning that prospective bidders need only a free registration to sign up for plan updates. Bidders assume all risk for acquiring specs and/or plans from third party sites and plan rooms, as only www.bidsync.com will be directly updated by the Owner.
5. The right is reserved by the Mayor and the City Council as the interests of the City may require to reject any or all bids and to waive any informality in bids received and to select the proposal deemed most advantageous to the City.
6. The Bidder (Proposer) must supply all the information required by the Proposal Form.
7. A Performance Bond, Labor and Material Payment Bond, and Maintenance Bond will be required by the Owner; each Bond shall be in the amount of 100% of the total contract amount. Bonds shall be issued by a surety company licensed by the State of Texas to act as a Surety and be listed on the current U.S. Treasury Listing of Approved Sureties.
8. For information on bidding, call Wil Newcomer, Purchasing Manager, Town of Addison, (972) 450-7091. All questions on the work to be performed shall be submitted through www.bidsync.com.
9. The project consists of Winnwood Pond silt removal and related improvements in accordance with the plans and specifications.
10. A **Pre-Bid Conference**, followed by a **Site Visit**, will be held at **10:00 a.m. on Monday, May 9, 2016** in the Conference Room of the Town of Addison Finance Building, 5350 Belt Line Road, Addison, Texas, (972) 450-7051.

Advertise:

May 3, 2016

May 10, 2016

May 17, 2016

SECTION IB

INSTRUCTIONS TO BIDDERS

INSTRUCTIONS TO BIDDERS

- A. PROJECT: POND DREDGING,** in the Town of Addison. The bids will be evaluated as stated in Section "O" of these Instructions to Bidders.
- B. PROJECT DESCRIPTION:** The project consists of the excavation, dewatering, and disposal of sedimentation from ponds; removal of existing structures, pipe, and electrical wires; and the replacement of grasses and other features disturbed by construction for Winnwood Pond Dredging Project.
- C. PROPOSALS:** Proposals must be in accordance with these instructions in order to receive consideration.
- D. DOCUMENTS:** Bidding Documents include the Project Manual (consisting of the Advertisement for Bids, these Instructions to Bidders, Proposal Forms, Contract Agreement, Performance Bond, Payment Bond, Maintenance Bond, Contractor's Affidavit of Bills Paid, General Provisions, Special Provisions, Project Sign, and Technical Specifications), a Waiver of Lien, Drawings, and Addenda which may be issued by the Town of Addison during the bidding period. Bidding Documents may be viewed and/or obtained under the terms and conditions set forth in the Advertisement for Bids, Section AB of this Project Manual.
- E. EXAMINATION OF DOCUMENTS AND SITE:** Bidders shall carefully examine the Bidding Documents and the construction site to obtain firsthand knowledge of the scope and the conditions of the Work. Each Contractor, Subcontractor and Sub-subcontractor, by submitting a proposal to perform any portion of the Work, represents and warrants that he has examined the Drawings, Specifications (Project Manual) and the site of the Work, and from his own investigation has satisfied himself as to the scope, accessibility, nature and location of the Work; the character of the equipment and other facilities needed for the performance of the Work; the character and extent of other work to be performed; the local conditions; labor availability, practices and jurisdictions; and other circumstances that may affect the performance of the Work. No additional compensation will be allowed by the Owner for the failure of such Contractor, Subcontractor or Sub-subcontractor to inform himself as to conditions affecting the Work. **A Pre-Bid Conference, followed by a Site Visit, will be held at 10:00 A.M. on Monday, May 9, 2016** in the Conference Room of the Town of Addison Finance Building, 5350 Belt Line Road, Addison, Texas, (972) 450-7051.
- F. INTERPRETATION OF DOCUMENTS:** If any person contemplating submitting a bid for the proposed Contract is in doubt as to the meaning of any part of the Drawings, Specifications (Project Manual) or other proposed Contract Documents, he may submit to the Town of Addison, not later than one (1) week prior to the date set for opening bids, a written request for an interpretation or clarification. Bidders should act promptly and allow sufficient time for a reply to reach them before preparing their bids. Any interpretation or clarification will be in the form of an Addendum duly issued. No alleged verbal interpretation or ruling will be held binding upon the Owner.
- G. SUBSTITUTIONS:** Conditions governing the submission of substitutions for specific materials, products, equipment and processes are in the Special Provisions. Requests for

substitutions must be received by the Town of Addison seven (7) calendar days prior to the established bid date.

H. ADDENDA: Interpretations, clarifications, additions, deletions and modifications to the Documents during the bidding period will be issued in the form of Addenda and a copy of such Addenda will be released through www.bidsync.com . It will be the responsibility of each person who has been issued a set of bid documents to secure all Addenda from www.bidsync.com. Addenda will be a part of the Bidding Documents and the Contract Documents, and receipt of them shall be acknowledged in the Bid Form. All such interpretations and supplemental instructions will be in the form of written addenda to the contract documents which, if issued, will be released through www.bidsync.com not later than three (3) calendar days prior to the date fixed for the opening of bids. If any bidder fails to acknowledge the receipt of such addenda in the space provided in the bid form, his bid will nevertheless be construed as though the receipt of such addenda had been acknowledged.

I. COMPLETION TIME: The completion time of the project will be 210 Calendar Days.

J. PREPARATION OF BIDS: Prices quoted shall include all items of cost, expense, taxes, fees and charges incurred by, or arising out of, the performance of the work to be performed under the Contract. Bids shall be submitted in duplicate and shall be signed in ink. Any bid on other than the required form will be considered informal and may be rejected. Erasures or other changes in a bid must be explained or noted over the initials of the bidder. Bids containing any conditions, omissions, unexplained erasures and alterations, or irregularities of any kind may be rejected as informal. The prices should be expressed in words and figures or they may be deemed informal and may be rejected. In case of discrepancy between the price written in the bid and that given in the figures, the price in writing will be considered as the bid. In the case of a discrepancy between a unit price and its extension, the unit price will govern. Failure to submit all requested information will make a bid irregular and subject to rejection. Bids shall be signed with name typed or printed below signature, and, if a partnership, give full name of all partners. Where bidder is a corporation, bids must be signed with the legal name of the corporation followed by the name of the state of incorporation and the legal signature of an officer authorized to bind the corporation to a contract.

NOTE: A COMPUTER-GENERATED PROPOSAL FORM MAY BE USED IN LIEU OF THE ENCLOSED FORMS. THE FORM SHALL BE 8 1/2" BY 11" IN SIZE, AND WILL BE ATTACHED TO THE PROPOSAL IN THE PROPER SECTION, AND WILL BE MADE PART OF THE PROPOSAL AND CONTRACT DOCUMENTS.

NOTE: THE SPREADSHEET OPTION IS FOR THE CONVENIENCE OF THE BIDDER. NO WORDING IN THE SPREADSHEET SHALL MODIFY OR AMEND THE WORDING IN THE BID PROPOSAL OR PLANS. THE UNIT PRICE ON THE FORM SHALL BE THE PRICE OF THE ITEM, AND ERRORS THAT MAY BE PRESENT IN THE PRINTOUT WILL NOT BE RECOGNIZED AS AN OPPORTUNITY TO REVISE THE PROPOSAL. THE SUMMARY SHEET INCLUDED IN THIS BID DOCUMENT SHALL BE UTILIZED FOR SUMMARIZING THE BID. THE SPREADSHEET SHALL PRESENT EACH ITEM IN THE ORDER AND NUMBER AS SHOWN IN THE CITY'S PROPOSAL AND BID SCHEDULE FOR THIS PROJECT. THE SPREADSHEET SHALL BE IN A COLUMN FORMAT WITH THE FOLLOWING COLUMNS:

1. ITEM NUMBER
2. DESCRIPTION & UNIT PRICE IN WORDS
3. UNIT OF MEASURE
4. UNIT PRICE
5. ESTIMATED QUANTITY
6. AMOUNT BID

K. SUBMITTAL OF BIDS: Sealed proposals will be received at the time, date and place stated in the Advertisement for Bids. Proposals shall be made on unaltered Proposal Forms furnished by the Town of Addison. Bidders shall submit proposals in an opaque, sealed envelope addressed to the Owner and plainly mark on the outside of the envelope the name and address of the bidder. The envelopes shall also be marked with the following project description:

INFRASTRUCTURE & DEVELOPMENT SERVICES BID NUMBER 16-92
WINNWOOD POND DREDGING PROJECT

The Bid Bond must be completed and signed by each bidder and submitted with the bid. Submit Bids by mail or in person prior to the time for receiving bids set forth in the Advertisement for Bids issued by the Town.

L. MODIFICATION AND WITHDRAWAL OF BIDS: Prior to the time set for bid opening, bids may be withdrawn or modified. Bids may be modified only on the official bid form and must be signed by a person legally empowered to bind the bidder. No bidder shall modify, withdraw, or cancel his bid or any part thereof for sixty (60) calendar days after the time agreed upon for the receipt of bids.

M. DISQUALIFICATION: The Owner reserves the right to disqualify proposals, before or after the opening, upon evidence of collusion with intent to defraud or other illegal practices relating to this proposal upon the part of the bidder.

N. SUBMISSION OF POST-BID INFORMATION: Upon notification of acceptance, the selected bidder shall, within five (5) calendar days, submit the following:

1. A designation of the portions of the Work proposed to be performed by the bidder with his own force.
2. A list of names of the Subcontractors or other persons or organizations, including those who are to furnish materials and equipment fabricated to a special design proposed for such portions of the Work as may be designated in the Bidding Documents or as may be requested by the Town of Addison. The bidder will be required to establish to the satisfaction of the Owner the reliability and responsibility of the proposed Subcontractors and suppliers to furnish and perform the Work.

O. AWARD: The Owner reserves the right to accept any or to reject any bids without compensation to bidders and to waive irregularities and informalities. The Town of Addison Infrastructure Operations & Services Department, in making its recommendation, will consider the following elements:

1. Whether the bidder is a contractor with experience in the type of work involved.

2. Whether the bidder has adequate plant, equipment and personnel to perform the work properly and expeditiously.
3. Whether the bidder has a suitable financial status and reputation for meeting obligations incident to work of the kind specified.
4. Whether the bidder has complied with the terms and conditions.

Alternate items may or may not be awarded. Addition or deletion of other items or schedules will be governed by the *Standard Specifications for Public Works Construction – North Central Texas, 4th Edition*, (hereinafter called SSPWC) Item 104.2 "Change or Modification of Contract".

- P. EXECUTION OF THE CONTRACT:** The successful bidder will be required to enter into a contract with the Owner within ten (10) days of notice by the Owner that his bid has been accepted. Failure to enter into a contract within the established time limit shall be considered grounds for forfeiture of the bid bond.
- Q. CONSTRUCTION SCHEDULE:** It is the Owner's desire to have the project completed and operational in as short a time as possible. The number of calendar days for completion of the project will begin with the date specified in the Notice to Proceed. The Notice to Proceed will be issued in a manner to facilitate a smooth construction of the project. The Contractor shall begin construction within ten (10) calendar days of the issuance of the Notice to Proceed.
- R. COST PLUS TIME BIDDING:** N/A
- S. FORM OF CONTRACT:** The contract for the construction of the project will be drawn up by the Owner. A sample form of agreement is included in the Contract Agreement Section.
- T. BONDS:** A Performance Bond, a Labor and Material Payment Bond and a Maintenance Bond will be required by the Owner. The Performance Bond and Payment Bond shall name the Town of Addison, and others as directed by the Town, as joint obligees. Sample forms have been included in the Performance Bond, Payment Bond, and Maintenance Bond sections. (Contractor shall confirm the legal names of obligees prior to execution of Bonds.)
- U. BID SECURITY:** Bids shall be accompanied by a cashier's check or certified check upon a national or state bank in an amount not less than five percent (5%) of the total maximum bid price payable without recourse to the Town of Addison, or a bid bond in the same amount from a surety company licensed to do business in the State of Texas as a guarantee that the bidder will enter into a contract and execute a Performance Bond and Payment Bond within ten (10) calendar days after notice of award of contract to him. Such checks or bid bonds will be returned to all except the three lowest bidders within three (3) days after the opening of bids, and the remaining checks or bid bonds will be returned promptly after the Owner has made an award of contract, or, if no award has been made within thirty (30) calendar days after the date of the opening of bids, upon demand of the bidder at any time thereafter, so long as he has not been notified of the acceptance of his bid.
- V. RESOLUTIONS:** If the bidder is a corporation, a copy of the resolution empowering the person submitting the bid to bind the bidder must be included with the bid.

- W. CONSTRUCTION STAKING:** Construction staking and re-staking will not be provided by the Owner. Benchmarks and Horizontal Control are shown on the plans. There is no separate bid item for staking, therefore, the contractor must include value for staking in the various bid items as subsidiary to the contract. Any staking or re-staking that is required shall be the responsibility of the Contractor and shall be at no cost to the Owner.
- X. FINAL PAYMENT:** The general provisions for Final Payment shall be as stated in Item 109.5.4 of the SSPWC including all Amendments and Additions. Prior to final payment the Contractor shall provide the Owner with the following items:
1. A Contractor's Affidavit of Bills Paid in accordance with Section BP.
 2. A Consent of Surety Company to Final Payment.
 3. A complete set of record plans which indicate all construction variations from the original construction documents in accordance with the Special Provisions.
 4. A two (2) year Maintenance Bond in accordance with Section MB.
 5. Acknowledgement that the project has been reviewed and accepted by TDLR.
- Y. PREVAILING WAGE RATES:** Wage rates paid on this project shall not be less than specified in the schedule of general prevailing rates of per diem wages as attached in the Special Provisions.
- Z. PRIORITY OF CONTRACT DOCUMENTS:** In case of conflict between contract documents, priority of interpretation shall be in the following order: signed agreement; performance and payment bonds; proposal; special provisions (or conditions); technical specifications; general provisions; advertisement for bids; project drawings; Standard Specifications for Public Works Construction (NCTCOG, October 2004); Town of Addison Standard Drawings. This priority list shall take precedence over Item 105.1.1 of the SSPWC.

SECTION PF
PROPOSAL FORM

PROPOSAL FORM

_____, 2016

TO: The Honorable Mayor and Town Council
Town of Addison, Texas

Gentlemen:

The undersigned bidder, having examined the plans, specifications and contract documents, and the location of the proposed work, and being fully advised as to the extent and character of the work, proposes to furnish all equipment and to perform labor and work necessary for completion of the work described by and in accordance with the Plans, Specifications and Contract for the following prices, to wit:

Signed by: _____

ACKNOWLEDGMENT OF ADDENDA:

The Bidder acknowledges receipt of the following addenda:

Addendum No. 1 _____

Addendum No. 2 _____

Addendum No. 3 _____

The following pages contain all bid items for:

BID SCHEDULE – WINNWOOD POND DREDGING PROJECT

BID SCHEDULE
WINNWOOD POND DREDGING PROJECT
BID NUMBER 16-92

Base Bid – Site Preparation and Miscellaneous

Item No.	Qty	Unit	Description/ Unit Price in Words	Unit Price in Figures	Total Amount
001	1	LS	Mobilization (No more than 5% of total bid) complete in place, the sum of _____ Dollars and _____ Cents per Lump Sum.	\$	\$
002	1	LS	Traffic Control complete in place, the sum of _____ Dollars and _____ Cents per Lump Sum.	\$	\$
003	1	LS	SW3P Including Maintenance, Inlet Protection, Erosion Control, and Construction Exit complete in place, the sum of _____ Dollars and _____ Cents per Lump Sum.	\$	\$
004	1	LS	Trench Safety System complete in place, the sum of _____ Dollars and _____ Cents per Lump Sum.	\$	\$
005	3	EA	Project Signs complete in place, the sum of _____ Dollars and _____ Cents per Each.	\$	\$

Item No.	Qty	Unit	Description/ Unit Price in Words	Unit Price in Figures	Total Amount
006	60	SY	Remove Existing Concrete Sidewalk complete in place, the sum of _____ Dollars and _____ Cents per Square Yard.	\$	\$
007	2	EA	Remove and Dispose of Existing Concrete Box Fountain (including Lights, Piping and Electrical Wires) complete in place, the sum of _____ Dollars and _____ Cents per Each.	\$	\$
008	2	EA	Remove and Dispose of Submersible Fountain Pump complete in place, the sum of _____ Dollars and _____ Cents per Each.	\$	\$
009	1	LS	Aquatic Species Recovery and Relocation Coordination complete in place, the sum of _____ Dollars and _____ Cents per Lump Sum.	\$	\$
010	6	MO	Bypass Pumping complete in place, the sum of _____ Dollars and _____ Cents per Month.	\$	\$
011	1	LS	Unwatering of Ponds complete in place, the sum of _____ Dollars and _____ Cents per Lump Sum.	\$	\$

Item No.	Qty	Unit	Description/ Unit Price in Words	Unit Price in Figures	Total Amount
012	5,000	CY	Desilting (including Excavation, Dewatering and Disposal of Contaminated Water) complete in place, the sum of _____ Dollars and _____ Cents per Cubic Yard.	\$	\$
013	5,000	CY	Sediment Disposal (including testing, permitting, transportation, and disposal) complete in place, the sum of _____ Dollars and _____ Cents per Cubic Yard.	\$	\$

SUB-TOTAL BASE BID (Items 001-013)

_____ **Dollars**
 _____ **Cents**

Base Bid – Paving and Sidewalks

Item No.	Qty	Unit	Description and Unit Price in Words	Unit Price in Figures	Total Amount
101	60	SY	Concrete Sidewalk complete in place, the sum of _____ Dollars and _____ Cents per Square Yard.	\$	\$
102	245	SY	Temporary Asphalt Sidewalk complete in place, the sum of _____ Dollars and _____ Cents per Square Yard.	\$	\$
103	24	CY	Flowable Fill Concrete complete in place, the sum of _____ Dollars and _____ Cents per Cubic Yard.	\$	\$

SUB-TOTAL BASE BID (Items 101-103)

_____ **Dollars**
 _____ **Cents**

Base Bid – Landscape Improvements

Item No.	Qty	Unit	Description and Unit Price in Words	Unit Price in Figures	Total Amount
201	12,300	SF	Soil Prep Material and Landscape Grading complete in place, the sum of _____ Dollars and _____ Cents per Square Foot.		
202	1,020	SY	Turf Reinforcement Mat complete in place, the sum of _____ Dollars and _____ Cents per Square Yard.		
203	8,500	SF	Common Bermuda 'Mid Iron' Sod complete in place, the sum of _____ Dollars and _____ Cents per Square Foot.		
204	5,000	SF	Wood Chips complete in place, the sum of _____ Dollars and _____ Cents per Square Foot.		
205	1	LS	Tree Trimming complete in place, the sum of _____ Dollars and _____ Cents per Lump Sum.		
206	1	EA	Tree Removal and Grubbing complete in place, the sum of _____ Dollars and _____ Cents per Each.		

Item No.	Qty	Unit	Description and Unit Price in Words	Unit Price in Figures	Total Amount
207	1	LS	Tree Protection complete in place, the sum of _____ Dollars and _____ Cents per Lump Sum.		
208	1	LS	90 Day Establishment Period complete in place, the sum of _____ Dollars and _____ Cents per Lump Sum.		
209	1	LS	1 Year Maintenance complete in place, the sum of _____ Dollars and _____ Cents per Lump Sum.		

SUB-TOTAL BASE BID (Items 201-209)

_____ Dollars
 _____ Cents

SUMMARY

BID SCHEDULE – WINNWOOD POND DREDGING PROJECT

1. Removal, Site Preparation and Miscellaneous Subtotal

(Item 001-013)....._____

2. Paving and Sidewalks Subtotal

(Items 101-103) _____

3. Landscape Improvements Subtotal

(Items 201-209) _____

TOTAL BID _____

Written in Words: _____

The pay items included in this proposal form comprise all of the pay items for the project. Any additional required work shall be considered subsidiary to the related pay items provided herein.

- NOTES:
1. All items, labor, materials, equipment, facilities, incidentals and work required for construction of the project are to be provided and installed by the Contractor as part of the project and payment for the cost of such shall be included in the price bid for the construction of the project.
 2. Prices must be shown in words and figures for each item listed in the Proposal. In the event of discrepancy, the words shall control.
 3. Materials, which are “tax exempt”, are those items which are physically incorporated into the facilities constructed for the Town of Addison, as set forth in the Special Provisions. Materials include, but are not limited to purchased items such as water pipe, sanitary sewer pipe, storm drain pipe, etc.

Services, which are “not tax exempt”, are those items which are used by the Contractor but are not physically incorporated into the Town of Addison’s facility and/or items which are consumed by construction, as set forth in the Special Provisions. Services include, but are not limited to, items such as supplies, tools, skill and labor, the purchase, rental or lease of equipment, etc.

Name of Person Signing Bid

Signature of Person Signing Bid

Address

Telephone No. Fax No.

T.I.N. (Tax Identification or Employer’s Number)

If BIDDER is:

AN INDIVIDUAL

By _____ (Individual's Name) (Seal)

doing business as _____

Business address: _____

Phone No. _____

A PARTNERSHIP

By _____ (Firm Name) (Seal)

_____ (General Partner)

doing business as _____

Business address: _____

Phone No. _____

A CORPORATION

By _____
(Corporation Name)

(State of Incorporation)

By _____
(Name of Person Authorized to Sign)

(Title)

(Corporate Seal)

Attest _____
(Secretary)

Business address: _____

Phone No. _____



A JOINT VENTURE

By _____
(Name)

(Address)

By _____
(Name)

(Address)

(Each joint venture must sign. The manner of signing for each individual, partnership and corporation that is a party to the joint venture should be in the manner indicated above.)

SECTION PQ

PREQUALIFICATION STATEMENT

**PREQUALIFICATION STATEMENT
FOR
PUBLIC IMPROVEMENTS
IN THE
TOWN OF ADDISON**

Contractor: _____ Date: _____

Project name, if applicable: _____

INSTRUCTIONS

All information on the PREQUALIFICATION STATEMENT FOR PUBLIC IMPROVEMENTS and the PREQUALIFICATION STATEMENT OF CONTRACTOR'S SURETY must be complete and the forms submitted together with bid documents as indicated in the Advertisement For Bids and Instructions to Bidders.

This Prequalification Statement consists of two (2) parts. The first part (Sections A through D) pertains to Contractor's status information and work history. The second part is the Prequalification Statement of Contractor's Surety, in which the Surety company will need to complete. Additional information/documentation from the Contractor or Surety Company may be required during the application review process.

CONTRACTOR INFORMATION:

Please complete the appropriate Section A, B, or C. All contractors must complete Section D.

SECTION A: If the contractor is a CORPORATION, complete this section

Name of corporation:

Registered name of corporation	Doing business as	
Date charter expires	State of corporation	Date of corporation filing (if non-Texas corporation, date Certificate of Authority was issued)

Registered agent:

First name	Middle name	Last name		
Address	City	County	State	Zip
Area code and phone number	Area code and fax number			
Area code and cell phone number	e-mail address			

Corporation's principal office:

Street address	City	County	State	Zip
Mailing address (if different from above)	City	County	State	Zip
Area code and phone number	Area code and fax number			

Person executing contract on behalf of corporation:

First name	Middle name	Last name	Title	
Street address	City	County	State	Zip
Mailing address (if different from above)	City	County	State	Zip
Area code and phone number	Area code and fax number	Federal Tax Identification No.		
Area code and cell phone number	e-mail address			

Additional Officers/Personnel:

First name	Middle name	Last name	Title
Area code and cell phone number		e-mail address	
First name	Middle name	Last name	Title
Area code and cell phone number		e-mail address	

SECTION B: If the contractor is a PARTNERSHIP, complete this section

First Partner:

First name	Middle name	Last name		
Residence Address	City	County	State	Zip
Area code and cell phone number		email address		

Second Partner:

First name	Middle name	Last name		
Residence Address	City	County	State	Zip
Area code and cell phone number		email address		

Business:

Name under which you are engaged in business (if operating under an assumed name)				Website Address
Street address	City	County	State	Zip
Mailing address (if different from above)	City	County	State	Zip
Principal place of business - County & State		Name of contact person		Title
Area code and phone number		Area code and fax number		Federal Tax Identification No.

SECTION C: If the contractor is a SOLE PROPRIETOR, complete this section

Name:

First name Middle name Last name

Business name under which you are engaged in business (if operating under an assumed name)

Residence:

Street address City County State Zip

Area code and phone number

Business:

Street address City County State Zip

Mailing address (if different from above) City County State Zip

Area code and phone number Area code and fax number Federal Tax Identification No.

Area code and cell phone number e-mail address

Principal place of business:

County State

Contact Person:

First name Middle name Last name Title

Area code and phone number Area code and fax number

Area code and cell phone number email address

SECTION D: Work history and references

1. Name of Bidder: _____

2. Do you operate under assumed name(s)? _____ If yes, please list:

3. How many years engaged in the contracting business under present firm or trade name? _____ Give former names of firm or trade names, with dates of operation under each:

4. Number of years in business as a general contractor on the types of work requesting to be prequalified for: _____

5. Types of work done: (check all that apply)

- | | | | |
|------------------------------------------|------------------------------------------------------|-----------------------------------------|-------------------------------------------------|
| <input type="checkbox"/> Asphalt Paving | <input type="checkbox"/> Concrete Structures | <input type="checkbox"/> Landscaping | <input type="checkbox"/> Subgrade Preparation |
| <input type="checkbox"/> Auxiliary Lanes | <input type="checkbox"/> Demolition | <input type="checkbox"/> Misc. Concrete | <input type="checkbox"/> Manhole Rehabilitation |
| <input type="checkbox"/> Bridge Work | <input type="checkbox"/> Earth Work | <input type="checkbox"/> Sidewalks | <input type="checkbox"/> Booster/Pump Stations |
| <input type="checkbox"/> Channel Lining | <input type="checkbox"/> Fencing | <input type="checkbox"/> Storm Sewer | <input type="checkbox"/> Tank Erection |
| <input type="checkbox"/> Concrete Paving | <input type="checkbox"/> Gabions | <input type="checkbox"/> Street Repair | <input type="checkbox"/> Plant Construction |
| <input type="checkbox"/> Painting | <input type="checkbox"/> Water & Sanitary Sewer Line | <input type="checkbox"/> Dredging | <input type="checkbox"/> Desilting |
| <input type="checkbox"/> Dewatering | <input type="checkbox"/> Other _____ | | |

6. List major construction equipments, such as paving machine or other equipments appropriate to perform work (for example, GOMACO GPH 2800 Slipform Paver): (use attachments if necessary)

7. Greatest number of contracts in excess of \$100,000 under construction at one time in the company's history:

8. Greatest number of contracts in excess of \$1,000,000 under construction at one time in the company's history:

9. Approximate average of dollar volume of incomplete work outstanding under contract at any one time:

10. List completed projects of the type of work qualifying for or similar work, plus the following information on each project: (use attachments if necessary)

a. _____
Project Year Built

Type(s) of work

Owner/Design Engineer	Contract Price	Contact Person	Area code and phone number
-----------------------	----------------	----------------	----------------------------

City Inspector/Contact Number (required)	City Engineer/Contact Number (optional)
------------------------------------------	-----------------------------------------

b. _____
Project Year Built

Type(s) of work

Owner/Design Engineer	Contract Price	Contact Person	Area code and phone number
-----------------------	----------------	----------------	----------------------------

City Inspector/Contact Number (required)	City Engineer/Contact Number (optional)
------------------------------------------	-----------------------------------------

c. _____
Project Year Built

Type(s) of work

Owner/Design Engineer	Contract Price	Contact Person	Area code and phone number
-----------------------	----------------	----------------	----------------------------

City Inspector/Contact Number (required)	City Engineer/Contact Number (optional)
------------------------------------------	-----------------------------------------

c.

Project Name and Location

Year Built

Describe Scope of Work

Owner/Design Engineer

Contract Price

Contact Person

Area code and phone number

City Inspector/Contact Number (required)

City Engineer/Contact Number (optional)

12. On the projects listed in response to question #11 above, what were the final project change order amounts? Were the projects completed within the specified timeframes (this includes both substantial completion and interim milestone dates)? If not, why not, and were any damages or liquidated damages paid to the Owner as a result of the late completion?

13. Background and experience of the Project Manager and Superintendent that will be utilized on this project. Include Owner references and contact names with area code and telephone numbers indicating experience with projects similar in size and to those listed in response to question #11 above.

14. Will a subcontractor be performing any work for this project? _____ If yes, provide subcontractor's name, address, telephone and provide information to question #s 15, 16, 17 below. (use attachments if necessary)

15. Subcontractor's experience in performing similar work within the past 10 years similar in cost and length to this project. Include, at a minimum, three (3) projects. (use attachments if necessary).

a. _____
Project Name and Location Year Built

Describe Scope of Work

Owner/Design Engineer Contract Price Contact Person Area code and phone number

City Inspector/Contact Number (required) City Engineer/Contact Number (optional)

b. _____
Project Name and Location Year Built

Describe Scope of Work

Owner/Design Engineer Contract Price Contact Person Area code and phone number

City Inspector/Contact Number (required) City Engineer/Contact Number (optional)

c. _____
Project Name and Location Year Built

Describe Scope of Work

Owner/Design Engineer Contract Price Contact Person Area code and phone number

City Inspector/Contact Number (required) City Engineer/Contact Number (optional)

16. On the projects listed in response to question #15 above, what were the final project change order amounts? Were the projects completed within the specified timeframes (this includes both substantial completion and interim milestone dates)? If not, why not, and were any damages or liquidated damages paid to the Owner as a result of the late completion?

17. If subcontractor is performing work, provide background and experience of the subcontractor's Project Manager and Superintendent that will be utilized on this project. Include Owner references and contact names with area code and telephone numbers indicating experience with projects similar in size and to those listed in response to question #15 above.

18. Have you even been terminated by the Owner of a project? If so, where and why? Give name of Owner.

19. List incomplete projects, plus the following information for each project listed:
(use attachments if necessary)

a.

Project				Year Built
Type(s) of work				
Owner/Design Engineer	Contract Price	Contact Person	Area code and phone number	
City Inspector/Contact Number (required)		City Engineer/Contact Number (optional)		

b.

Project				Year Built
Type(s) of work				
Owner/Design Engineer	Contract Price	Contact Person	Area code and phone number	
City Inspector/Contact Number (required)		City Engineer/Contact Number (optional)		

c.

Project				Year Built
Type(s) of work				
Owner/Design Engineer	Contract Price	Contact Person	Area code and phone number	
City Inspector/Contact Number (required)		City Engineer/Contact Number (optional)		

20. Have you or any present partner(s) or officer(s) failed to complete a contract? _____

If yes, name of project				Year built
Owner/Engineer	Contract price	Contact person	Area code & phone number	
Name of owner and/or surety	Contact person		Area code & phone number	

21. Are there any unsatisfied demands upon you as to your accounts payable? _____

If yes, give names, amounts, and explanations:

22. Bank reference (use additional sheets of paper, if necessary):

Name of bank		Bank officer		
Mailing address	City	County	State	Zip
Area code and phone number			Area code and fax number	

23. Municipality reference (use additional sheets of paper, if necessary):

Name of city	Contact person			Title
Mailing address	City	County	State	Zip
Area code and phone number		Area code and fax number		
Area code and cell phone number		e-mail address		

24. Other credit references:

a.

Name	Area code and phone number		Area code and fax number	
Address	City	County	State	Zip
Area code and cell phone number		e-mail address		

b.

Name	Area code and phone number		Area code and fax number	
Address	City	County	State	Zip
Area code and cell phone number		e-mail address		

25. Will you, upon request, fill out a detailed financial statement and furnish any other pertinent information that may be required by the Town of Addison?

26. Please provide OSHA safety record, including a list and status of all OSHA violations.

Pursuant to advertisement for bids and information for prospective bidders for above-mentioned types of projects, the undersigned is submitting the information as required with the understanding that the purpose is for your confidential use, only to assist in determining the **Prequalifications** for this organization to perform the type and magnitude of work designated, and further, guarantee the truth and accuracy of all statements made, and will accept your determination of prequalifications without prejudice. The surety herein named, any other bonding company, bank, subcontractor, supplier, or any other person(s), firm(s), or corporation(s) with whom I (we) have done business, or who have extended any credit to me (us) are hereby authorized to furnish you with any information you may request concerning performance on previous work and my (our) credit standing with any of them; and I (we) hereby release any and all such parties from any legal responsibility whatsoever on account of having furnished such information to you.

CONTRACTOR:

Copy to local underwriting office of proposed surety:

Company name (please type or print)

Company name (please type or print)

Signature

Address

Title

City State Zip

Date

Area code and phone number Fax number

SECTION BB
BID BOND

BID BOND

Bidder shall submit a bid bond equal to five percent (5%) of the bid price. Failure to submit a bid bond when required may deem the bid non-responsive. Bid Bonds may NOT be submitted electronically.

SECTION CI
INDEMNIFICATION AGREEMENT

Town of Addison Indemnification Agreement

Contractor's Indemnity Obligation. Contractor covenants, agrees to, and shall DEFEND (with counsel reasonably acceptable to Owner), INDEMNIFY, AND HOLD HARMLESS Owner, its past, present and future elected and appointed officials, and its past, present and future officers, employees, representatives, and volunteers, individually or collectively, in both their official and private capacities (collectively, the "**Owner Persons**" and each being an "**Owner Person**"), from and against any and all claims, liabilities, judgments, lawsuits, demands, harm, losses, damages, proceedings, suits, actions, causes of action, liens, fees (including attorney's fees), fines, penalties, expenses, or costs, of any kind and nature whatsoever, made upon or incurred by Owner and/or Owner Person, whether directly or indirectly, (the "**Claims**"), that arise out of, result from, or relate to: (i) the services to be provided by Contractor pursuant to this Agreement, (ii) any representations and/or warranties by Contractor under this Agreement, (iii) any personal injuries (including but not limited to death) to any Contractor Persons (as hereinafter defined) and any third persons or parties, and/or (iv) any act or omission under, in performance of, or in connection with this Agreement by Contractor or by any of its owners, directors, officers, managers, partners, employees, agents, contractors, subcontractors, invitees, patrons, guests, customers, licensees, sublicensees, or any other person or entity for whom Contractor is legally responsible, and their respective owners, directors, officers, directors, officers, managers, partners, employees, agents, contractors, subcontractors, invitees, patrons, guests, customers, licensees, sublicensees (collectively, "**Contractor Persons**"). **SUCH DEFENSE, INDEMNITY AND HOLD HARMLESS SHALL AND DOES INCLUDE CLAIMS ALLEGED OR FOUND TO HAVE BEEN CAUSED IN WHOLE OR IN PART BY THE NEGLIGENCE OR GROSS NEGLIGENCE OF OWNER OR ANY OTHER OWNER PERSON, OR CONDUCT BY OWNER OR ANY OTHER OWNER PERSON THAT WOULD GIVE RISE TO STRICT LIABILITY OF ANY KIND.**

Contractor shall promptly advise Owner in writing of any claim or demand against any Owner Person related to or arising out of Contractor's activities under this Agreement and shall see to the investigation and defense of such claim or demand at Contractor's sole cost and expense. The Owner Persons shall have the right, at the Owner Persons' option and own expense, to participate in such defense without relieving Contractor of any of its obligations hereunder. This defense, indemnity, and hold harmless provision shall survive the termination or expiration of this Agreement.

The provisions in the foregoing defense, indemnity and hold harmless are severable, and if any portion, sentence, phrase, clause or word included therein shall for any reason be held by a court of competent jurisdiction to be invalid, illegal, void, or unenforceable in any respect, such invalidity, illegality, voidness, or unenforceability shall not affect any other provision thereof, and this defense, indemnity and hold harmless provision shall be considered as if such invalid, illegal, void, or unenforceable provision had never been contained in this Agreement. **In that regard, if the capitalized language included in the foregoing indemnity is so determined to be void or unenforceable, the parties agree that:**

(i) the foregoing defense, indemnity, and hold harmless obligation of Contractor shall be to the extent Claims are caused by, arise out of, or result from, in whole or in part, any act or omission of Contractor or any Contractor Persons; and

(ii) notwithstanding the provisions of the foregoing subparagraph (i), to the fullest extent permitted by law, Contractor shall INDEMNIFY, HOLD HARMLESS, and DEFEND Owner and Owner Persons from and against all Claims arising out of or resulting from bodily injury to, or sickness, disease or death of, any employee, agent or representative of Contractor or any of its subcontractors, regardless of whether such Claims are caused, or are alleged to be caused, in whole or in part, by the negligence, or any act or omission, of Owner or any Owner Persons, it being the expressed intent of Owner and Contractor that IN SUCH EVENT THE CONTRACTOR'S INDEMNITY, HOLD HARMLESS, AND DEFENSE OBLIGATION SHALL AND DOES INCLUDE CLAIMS ALLEGED OR FOUND TO HAVE BEEN CAUSED IN WHOLE OR IN PART BY THE NEGLIGENCE OR GROSS NEGLIGENCE OF OWNER OR ANY OTHER OWNER PERSON, OR CONDUCT BY OWNER OR ANY OTHER OWNER PERSON THAT WOULD GIVE RISE TO STRICT LIABILITY OF ANY KIND. The indemnity obligation under this subparagraph (ii) shall not be limited by any limitation on the amount or type of damages, compensation, or benefits payable by or for Contractor under workers compensation acts, disability benefit acts, or other employee benefit acts.

I understand that the indemnification provisions are required of all Town of Addison Contracts. I have read the provisions and agree to the terms of these provisions.

Project/Bid#: _____

Company Name: _____

Signature: _____ Date: _____

SECTION CA

CONTRACT AGREEMENT

CONTRACT AGREEMENT

STATE OF TEXAS

COUNTY OF DALLAS

THIS AGREEMENT is made and entered into this _____ day of _____, 2016, by and between the Town of Addison, of the County of Dallas and State of Texas, acting through its City Manager, thereunto duly authorized so to do, Party of the First Part, hereinafter termed the OWNER, and _____, of the City of _____, County of _____, State of _____, Party of the Second Part, hereinafter termed CONTRACTOR.

WITNESSETH: That for and in consideration of the payment and agreement hereinafter mentioned, to be made and performed by the OWNER, the said CONTRACTOR hereby agrees with the said OWNER to commence and complete construction of certain improvements as follows:

WINNWOOD POND DREDGING PROJECT

INFRASTRUCTURE & DEVELOPMENT SERVICES BID NUMBER 16-92

and all extra work in connection therewith, under the terms as stated in the General and Specific Conditions of the AGREEMENT; and at his own proper cost and expense to furnish all the materials, supplies, machinery, equipment, tools, superintendence, labor, insurance and other accessories and services necessary to complete the said construction, in accordance with the conditions and prices stated in the Proposal attached hereto and in accordance with the Advertisement for Bids, Instructions to Bidders, General Provisions, Special Provisions, Plans, and other drawings and printed or written explanatory matter thereof, and the Technical Specifications and Addenda thereto, as prepared by the OWNER, each of which has been identified by the endorsement of the CONTRACTOR and the OWNER thereon, together with the CONTRACTOR's written Proposal and the General Provisions, all of which are made a part hereof and collectively evidence and constitute the entire AGREEMENT. The completion of Form 1295 will be required as part of this contract per new State requirements effective 1/1/16.

The CONTRACTOR hereby agrees to commence work within ten (10) calendar days after the date of written notice to do so shall have been given to him, to complete the work within **two hundred and ten (210)** calendar days, after he commences work, subject to such extensions of time as are provided by the General Provisions.

The OWNER agrees to pay the CONTRACTOR _____ Dollars (\$ _____) in current funds for the performance of the Contract in accordance with the Proposal submitted thereof, subject to additions and deductions, as provided in the General Provisions, and to make payments of account thereof as provided therein.

IN WITNESS WHEREOF, the parties of these presents have executed this AGREEMENT in the year and day first above written.

TOWN OF ADDISON, TEXAS (OWNER)

ATTEST:

By: _____
Wesley S. Pierson, City Manager

By: _____
Chris Terry, Assistant City Manager

(CONTRACTOR)

ATTEST:

By: _____

By: _____

The following to be executed if the CONTRACTOR is a corporation:

I, _____ certify that I am the secretary of the corporation named as CONTRACTOR herein; that _____, who signed this Contract on behalf of the CONTRACTOR is the _____ (official title) of said corporation; that said Contract was duly signed for and in behalf of said corporation by authority of its governing body, and is within the scope of its corporate powers.

Signed: _____

Corporate Seal

SECTION PrB
PERFORMANCE BOND

PERFORMANCE BOND

STATE OF TEXAS }
COUNTY OF DALLAS }

WHEREAS, _____ as principal ("Contractor") and _____, a corporation organized under the laws of _____ and being duly authorized to do business in the State of Texas, as surety ("Surety")(whether one or more), do hereby expressly acknowledge themselves to be held and bound to pay to the Town of Addison, Texas, a home-rule municipality organized and operating under the Constitution and laws of the State of Texas (the "Town"), its successors and assigns, and to all persons, firms, subcontractors and corporations who may furnish materials or labor under the contract as more fully described below, the sum of _____ Dollars in the lawful currency of the United States of America (\$) for the payment of which Contractor and Surety are liable to the Town, jointly and severally; and

WHEREAS, Contractor has this day entered into a written contract with the Town to build and construct _____

_____ which contract and the plans and specifications therein mentioned (collectively referred to hereinafter as the "Contract") are hereby expressly incorporated into and made a part hereof as though set forth at length; and

WHEREAS, this bond is given pursuant to Chapter 2253 of the Texas Government Code;

NOW, THEREFORE, if Contractor shall well, truly and faithfully perform all of the undertakings, duties, terms, conditions and agreements of the Contract; shall satisfy all claims and demands incurred under the Contract; shall fully indemnify and hold the Town harmless; shall reimburse and repay the Town for any outlay or expense which the Town may incur in making good any default, and shall promptly make payment to all persons, firms, subcontractors and corporations who may furnish materials or labor under the Contract, then this obligation shall be void; otherwise to remain in full force and effect. The obligations of Contractor and Surety under this bond apply both to the original Contract and to any extension or modification of the Contract and Surety agrees that no change, extension of time, addition, expansion or other modification of the Contract, the work to be done under the Contract, or the plans and specifications which are a part of the Contract shall in any manner affect the obligations of Surety under this bond, and Surety waives notice of any such change, extension of time, addition, expansion or other modification. The obligations of Contractor and Surety under this bond are performable and payable in Dallas County, Texas such that exclusive venue for any legal action pertaining to this bond shall lie in Dallas County, Texas. By their signatures below, the persons signing this bond warrant and represent that they are, respectively, duly authorized to sign on behalf of Contractor and Surety.

EXECUTED this the ____ day of _____, 2____.

CONTRACTOR: _____ SURETY: 1
By: _____ By: _____
Title: _____ Title: _____

ACKNOWLEDGMENTS
[Contractor]

STATE OF TEXAS }
COUNTY OF DALLAS }

Before me _____ (insert the name of the officer) on this day _____ personally appeared _____ known to me (or proved to me on the oath of _____) or through _____ (description of identity card or other document) to be the person whose name is subscribed to the forgoing instrument and acknowledged to me that he/she executed the same for the purpose and consideration therein expressed.

Given under my hand and seal of office this _____ day of _____, 2____.

Notary Public in and for the State of Texas _____ Typed or Printed Name of Notary
My Commission Expires: _____

[Surety]

STATE OF TEXAS }
COUNTY OF DALLAS }

This instrument was acknowledged before me on the ____ day of _____, 2____ by _____ who is the _____ of the Surety, on behalf of Surety.

GIVEN UNDER MY HAND AND SEAL OF OFFICE this the ____ day of _____, 2____.

Notary Public in and for the State of Texas _____ Typed or Printed Name of Notary
My Commission Expires: _____

1 Please see attached contact sheet for Surety and the Texas Department of Insurance.

Payment and Performance Bond Contact Sheet

(1) Claims:

All notices of claims shall be sent to the surety at the following address:

(Name of surety)

(Mailing address)

(Physical address)

(Phone number)

(2) Texas Department of Insurance Contact Number:

The address and contact information of the surety may otherwise be obtained by contacting the Texas Department of Insurance at the following toll free telephone number:

1-800-252-3439.

SECTION PyB
PAYMENT BOND

PAYMENT BOND

STATE OF TEXAS }
COUNTY OF DALLAS }

WHEREAS, _____, as principal ("Contractor") and _____, a corporation organized under the laws of _____ and being duly authorized to do business in the State of Texas, as surety ("Surety")(whether one or more), do hereby expressly acknowledge themselves to be held and bound to pay to the Town of Addison, Texas, a home-rule municipality organized and operating under the Constitution and laws of the State of Texas (the "Town"), its successors and assigns, and to all persons, firms, subcontractors and corporations who may furnish materials or labor under the contract as more fully described below, the sum of _____ Dollars in the lawful currency of the United States of America (\$) for the payment of which Contractor and Surety are liable to the Town, jointly and severally; and

WHEREAS, Contractor has this day entered into a written contract with the Town to build and construct _____

which contract and the plans and specifications therein mentioned (collectively referred to hereinafter as the "Contract") are hereby expressly incorporated into and made a part hereof as though set forth at length; and

WHEREAS, this bond is given pursuant to Chapter 2253 of the Texas Government Code;

NOW, THEREFORE, if Contractor shall promptly make payment to all persons, firms, subcontractors and corporations who may furnish materials or labor under the Contract, then this obligation shall be void; otherwise to remain in full force and effect. The obligations of Contractor and Surety under this bond apply both to the original Contract and to any extension of time or modification of the Contract and Surety agrees that no change, extension of time, addition, expansion or other modification of the Contract, the work to be done under the Contract, or the plans and specifications which are a part of the Contract shall in any manner affect the obligations of Surety under this bond, and Surety waives notice of any such change, extension of time, addition, expansion or other modification. The obligations of Contractor and Surety under this bond are performable and payable in Dallas County, Texas such that exclusive venue for any legal action pertaining to this bond shall lie in Dallas County, Texas. By their signatures below, the persons signing this bond warrant and represent that they are, respectively, duly authorized to sign on behalf of Contractor and Surety.

EXECUTED this the _____ day of _____, 2_____.

CONTRACTOR:

SURETY: 1

By: _____

By: _____

Title: _____

Title: _____

ACKNOWLEDGMENTS
[Contractor]

STATE OF TEXAS }
COUNTY OF DALLAS }

Before me _____ (insert the name of the officer) on this day _____ personally appeared _____ known to me (or proved to me on the oath of _____) or through _____ (description of identity card or other document) to be the person whose name is subscribed to the forgoing instrument and acknowledged to me that he/she executed the same for the purpose and consideration therein expressed.

Given under my hand and seal of office this _____ day of _____, 2_____.

Notary Public in and for the State of Texas
My Commission Expires: _____

Typed or Printed Name of Notary

[Surety]

STATE OF TEXAS }
COUNTY OF DALLAS }

This instrument was acknowledged before me on the _____ day of _____, 2_____ by _____ who is the _____ of the Surety, on behalf of Surety.

GIVEN UNDER MY HAND AND SEAL OF OFFICE this the _____ day of _____, 2_____.

Notary Public in and for the State of Texas
My Commission Expires: _____

Typed or Printed Name of Notary

1 Please see attached contact sheet for Surety and the Texas Department of Insurance

Payment and Performance Bond Contact Sheet

(1) Claims:

All notices of claims shall be sent to the surety at the following address:

(Name of surety)

(Mailing address)

(Physical address)

(Phone number)

(2) Texas Department of Insurance Contact Number:

The address and contact information of the surety may otherwise be obtained by contacting the Texas Department of Insurance at the following toll free telephone number:

1-800-252-3439.

SECTION MB
MAINTENANCE BOND

MAINTENANCE BOND – TWO YEAR

STATE OF TEXAS

COUNTY OF DALLAS

WHEREAS, _____, as principal ("Contractor") and _____, a corporation organized under the laws of _____ and being duly authorized to do business in the State of Texas, as surety ("Surety")(whether one or more), do hereby expressly acknowledge themselves to be held and bound to pay to the Town of Addison, Texas, a home-rule municipality organized and operating under the Constitution and laws of the State of Texas (the "Town"), its successors and assigns the sum of _____ Dollars in the lawful currency of the United States of America (\$) for the payment of which Contractor and Surety are liable to the Town, jointly and severally; and

WHEREAS, Contractor has this day entered into a written contract with the Town to build and construct which contract and the plans and specifications therein mentioned (collectively referred to hereinafter as the "Contract") are hereby expressly incorporated into and made a part hereof as though set forth at length; and

WHEREAS, under the Contract it is provided that the Contractor will maintain and keep in good repair all work to be performed and done under the Contract for a period of two (2) year from the date of acceptance of the completed work by the Town, and to do and perform all necessary work and repair any defective condition, it being understood that the purpose of this maintenance bond is to insure all warranties, express or implied, made or given by the Contractor to the Town and to cover all defective, inadequate or non-conforming conditions arising by reason of any materials or labor installed, provided, constructed or performed by the Contractor and in case the Contractor shall fail to correct any such conditions it is agreed that the Town may make such corrections and charge the cost of making those corrections against the Contractor and the Surety on this obligation, and the Contractor and Surety shall be subject to the liquidated damages provided in the contract, the plans and the specifications for each day's failure on its part to comply with the terms and provisions of the Contract;

NOW, THEREFORE, if the Contractor shall keep and perform its obligation to maintain the work and keep the work in repair for the full maintenance period of two (2) year as herein provided, then these presents shall be null and void and have no further effect, but if default shall be made by Contractor in the performance of its obligations, then these presents shall have full force and effect, and the Town shall have and recover from the Contractor and its Surety damages in the premises as provided and it is further understood and agreed that this obligation shall be a continuing one against the Contractor and the Surety and that successive recoveries may be had hereon for successive breaches until the full amount of this bond shall have been exhausted; and it is further understood that the obligation under this bond to maintain the work shall continue throughout the maintenance period and shall not be changed, diminished, or in any other manner affected during the term of this bond. The obligations of Contractor and Surety under this bond apply both to the original Contract and to any extension or modification of the Contract and Surety agrees that no change, extension of time, addition, expansion or other modification of the Contract, the work to be done under the Contract, or the plans and specifications which are a part of the Contract shall in any manner affect the obligations of Surety under this bond, and Surety waives notice of any such change, extension of time, addition, expansion or other modification. The obligations of Contractor and Surety under this bond are performable and payable in Dallas County, Texas such that exclusive venue for any legal action pertaining to this bond shall lie in Dallas County, Texas. By their signatures below, the persons signing this bond warrant and represent that they are, respectively, duly authorized to sign on behalf of Contractor and Surety.

EXECUTED this the _____ day of _____, 2_____.
CONTRACTOR: _____ SURETY: _____

By: _____ By: _____
Printed Name: _____ Printed Name: _____
Title: _____ Title: _____
Address of Principal: _____ Address of Surety: _____

ACKNOWLEDGMENTS
[Contractor]

STATE OF TEXAS
COUNTY OF DALLAS

Before me _____ (insert the name of the officer) on this day _____ personally appeared _____ known to me (or proved to me on the oath of _____) or through _____ (description of identity card or other document) to be the person whose name is subscribed to the forgoing instrument and acknowledged to me that he/she executed the same for the purpose and consideration therein expressed.

Given under my hand and seal of office this _____ day of _____, 2_____.

Notary Public in and for the State of Texas _____ Typed or Printed Name of Notary
My Commission Expires: _____
[Surety]

STATE OF TEXAS
COUNTY OF DALLAS

This instrument was acknowledged before me on the ___ day of _____, 2____ by _____ who is the _____ of the Surety, on behalf of Surety.

GIVEN UNDER MY HAND AND SEAL OF OFFICE this the _____ day of _____, 2_____.

Notary Public in and for the State of Texas _____ Typed or Printed Name of Notary
2-4-13 2 yr

SECTION BP

CONTRACTOR'S AFFIDAVIT OF BILLS PAID

CONTRACTOR'S AFFIDAVIT OF BILLS PAID

STATE OF TEXAS

COUNTY OF DALLAS

Personally, before me the undersigned authority, on this day appeared _____ who, being
duly sworn, on oath, says that he is a legal representative of _____
(full name of Contractor as in contract)

and that the contract for the construction of the project, designated as

WINNWOOD POND DREDGING PROJECT

INFRASTRUCTURE & DEVELOPMENT SERVICES BID NUMBER 16-92

has been satisfactorily completed and that all bills for materials, apparatus, fixtures, machinery and labor used in connection with the construction of this project have, to the best of my knowledge and belief, been fully paid.

Signature

Title

Sworn to and subscribed before me this _____ day of _____, 201_.

Notary Public in and for

County, Texas

Instructions:

If the contractor is an individual, he shall sign the affidavit. If the contractor is a partnership, any partner may sign the affidavit. If the contractor is a corporation, a person authorized by the by-laws or by the Board of Directors shall sign the affidavit. If the Contractor is a joint-venture of individuals, any of the individuals may sign the affidavit. If the Contractor is a joint-venture of partnerships, or of individuals and partnerships, the affidavit may be signed by the individual or any partner of any partnership. If the contractor is a joint-venture in which a corporation is a party, separate affidavits must be executed in the name of the joint-venture: one by each corporation and one by each individual or partnership. Signatures for corporations should be by a duly authorized officer. If signature is by another, a showing of authority to sign must accompany the affidavit.

SECTION GP

GENERAL PROVISIONS

GENERAL PROVISIONS

The General Provisions of the Contract shall be as stated in the *Standard Specifications for Public Works Construction – North Central Texas, 4th Edition (2004)*, under Division 100, "General Provisions," Items 101.1 through 109.6 inclusive, as amended or supplemented and except as modified by the Special Provisions, Instructions to Bidders, and Technical Specifications.

SECTION SP

SPECIAL PROVISIONS

SPECIAL PROVISIONS
TABLE OF CONTENTS

<u>Section</u>	<u>Title</u>	<u>Page</u>
1.	Scope of Work	SP - 5
2.	General	SP - 5
3.	Examination of Site	SP - 5
4.	Specifications	SP - 5
5.	Subsurface Investigation	SP - 6
6.	Compliance with Laws.....	SP - 6
7.	Permits, Licenses and Regulations.....	SP - 6
8.	Rights-of-Way and Easements	SP - 6
9.	Restricted Work Hours	SP - 7
10.	Compliance with Immigration Laws.....	SP - 7
11.	Non-Discrimination Policy	SP - 7
12.	Antitrust Laws.....	SP - 7
13.	Abandonment	SP - 7
14.	Discrepancies	SP - 7
15.	Preparation of Storm Water Pollution Prevention Plan	SP - 8
16.	Addenda	SP - 8
17.	Pay Items	SP - 9
18.	Increase or Decrease in Quantities	SP - 9
19.	Subsidiary Work	SP - 9
20.	Qualification of Bids	SP - 9
21.	Award and Execution of Contract.....	SP - 10
22.	Explanation of Contract Time.....	SP - 10
23.	Copies of Plans Furnished	SP - 11
24.	Pre-Construction Conference.....	SP - 11
25.	Mobilization.....	SP - 11
26.	General Sequence of Construction.....	SP - 11
27.	Project Representative	SP - 11
28.	Coordination with Others.....	SP - 12
29.	Insurance/Indemnification.....	SP - 12
30.	Workers' Compensation Insurance Coverage.....	SP - 14
31.	Clean Air Act and Clean Water Act.....	SP - 17
32.	Resolution of Disputes	SP - 17
33.	Shop Drawings	SP - 17
34.	Project Video	SP - 17
35.	Samples and Tests of Materials	SP - 18
36.	Inspection	SP - 18
37.	Access Routes, Staging Areas and Storage Areas	SP - 18
38.	Property Access.....	SP - 18
39.	Plant, Procedure, Methods and Equipment.....	SP - 19

<u>Section</u>	<u>Title</u>	<u>Page</u>
40.	Parking of Construction Equipment.....	SP - 19
41.	Zoning Requirements.....	SP - 19
42.	Construction in Public Roads and Private Drives.....	SP - 19
43.	Hauling on Town of Addison Streets.....	SP - 20
44.	Existing Power Poles and Guy Wires.....	SP - 20
45.	Safety Restrictions - Work Near High Voltage Lines.....	SP - 20
46.	Protection of Existing Utilities and Structures.....	SP - 21
47.	Public Utilities and Other Property to be Changed.....	SP - 21
48.	Maintenance and Repairs.....	SP - 22
49.	Protection of Work.....	SP - 22
50.	Public Convenience and Safety.....	SP - 22
51.	Protection of Persons and Property.....	SP - 23
52.	Traffic Control.....	SP - 24
53.	Barricades, Warning Signs, Detours and Sequence of Construction.....	SP - 25
54.	Excavation Safety Systems.....	SP - 25
55.	Trench Excavation, Backfill and Compaction.....	SP - 26
56.	Trench Walls.....	SP - 27
57.	Property Lines and Monuments.....	SP - 27
58.	Construction Staking.....	SP - 27
59.	Vendor's Certification.....	SP - 28
60.	Water Pipe.....	SP - 28
61.	Wastewater Pipe.....	SP - 28
62.	Storm Drainage Pipe.....	SP - 28
63.	Polyethylene Wrapping.....	SP - 28
64.	Pipe Cleaning.....	SP - 28
65.	Plugs.....	SP - 29
66.	Cement Stabilized Backfill.....	SP - 29
67.	Non-Metallic Water Pipe Detection.....	SP - 29
68.	Pipe Embedment.....	SP - 29
69.	Removals, Adjustments and Replacements.....	SP - 29
70.	Pavement Repair.....	SP - 30
71.	Water for Construction.....	SP - 30
72.	Existing Stockpiles of Material on Site.....	SP - 30
73.	Borrow Source.....	SP - 30
74.	Excess Material.....	SP - 31
75.	During Construction.....	SP - 31
76.	Construction Traffic Over Pipe Lines.....	SP - 31
77.	Contractor's Continuing Obligation.....	SP - 31
78.	Topsoiling, Seeding and Fertilizing.....	SP - 32
79.	Irrigation and Sprinkler Repair.....	SP - 32
80.	Removal of Defective and Unauthorized Work.....	SP - 32
81.	Disposition and Disposal of Materials.....	SP - 32

<u>Section</u>	<u>Title</u>	<u>Page</u>
82.	Clean-up for Final Acceptance	SP - 33
83.	TV Inspection of Sanitary Sewer and Storm Drain Systems	SP - 33
84.	Materials to be Furnished by Franchise Utility Companies	SP - 33
85.	Testing Requirements	SP - 33
86.	Silicone Joint Sealant.....	SP - 33
87.	Claims for Damages or Injury.....	SP - 33
88.	Waiver of Claims	SP - 34
89.	Mechanic's and Material men's Lien.....	SP - 34
90.	Contractor's Affidavit of Bills Paid.....	SP - 34
91.	Project Record Documents	SP - 34
92.	Town of Addison Approval	SP - 35
93.	Use of Explosives	SP - 35
94.	Power for Construction	SP - 36
95.	Liquidated Damages	SP - 36
96.	Prevailing Wage Rates	SP - 36
97.	Reference Specifications.....	SP - 39
98.	Bid Item Descriptions	SP - 41

SPECIAL PROVISIONS

1. **SCOPE OF WORK:** The work to be performed under the provisions of these Contract Documents shall consist of furnishing all materials, labor, equipment, supplies and appurtenances; providing all construction, dredging, dewatering, planting, equipment and tools; performing all necessary labor and supervision; and the construction complete, including all work appurtenant thereto, the proposed improvements for: *Winnwood Pond Dredging Project*.

2. **GENERAL:** This work shall conform to the requirements of the specifications and the details as shown on the Drawings. These Contract Documents are intended to be complementary. Requirements of any of the Contract Documents are as binding as if called for by all. In the event of conflict between the Drawings and the Specifications, the Contractor will be deemed to have assumed the more expensive way of doing the work unless, before submitting a bid, the Contractor shall have asked for and obtained (by addendum) a written decision as to which method or material is intended.

In cases of discrepancies, calculated dimensions shall govern over scaled dimensions; special provisions and special specifications shall govern over both general and standard specifications; and quantities shown on the plans shall govern over those shown in the proposal.

3. **EXAMINATION OF SITE:** The Contractor acknowledges that he has investigated and satisfied himself as to the conditions affecting the work, including but not restricted to those bearing upon transportation, disposal, handling and storage of materials, availability of labor, water, electric power, roads and uncertainties of weather, or similar physical conditions at the site, conditions of the ground, the character of equipment and facilities needed preliminary to and during prosecution of the work. The Contractor acknowledges that he has inspected the site of the work and is familiar with the soil conditions to be encountered. Any failure by the Contractor to acquaint himself with the available information will not relieve him from responsibility for estimating properly the difficulty or cost of successfully performing the work. The Town of Addison assumes no responsibility for any conclusions or interpretations made by the Contractor on the basis of the information made available by the Town and the Engineer.

4. **SPECIFICATIONS:** Construction improvements shall be governed by the following published specifications and details (except as modified by these Special Provisions):

Standard Specifications for Public Works Construction, North Central Texas - North Central Texas Council of Governments (latest edition);

Standard Specifications for Construction and Maintenance of Highways, Streets, and Bridges – Texas Department of Transportation, 2004;

Town of Addison Standard Construction Details;

The Contractor shall keep copies of applicable specifications on the project site at all times. Where reference is made to specifications compiled by other agencies, organizations or departments, such referenced specifications are hereby made a part of the project specifications.

5. **SUBSURFACE INVESTIGATION:** There is no subsurface geotechnical report prepared for this project. Subsurface exploration to ascertain the nature of soils, including the amount of rock, if any, is the responsibility of any and all prospective bidders. It shall be the responsibility of the bidders to make such subsurface investigations as he deems necessary to determine the nature of the material to be encountered. Some preliminary subsurface exploration has been performed by the Town of Addison and the Engineer, and is provided to the Contractor in the plan documents. This information is provided only as preliminary and all bids shall be based on information obtained by the Contractor. The Town of Addison and the Engineer disclaim any responsibility for the accuracy, true location and extent of the soils information that has been prepared by others. They further disclaim responsibility for interpretation of that data by bidders, as in projecting soil bearing values, rock profiles, soils stability and the presence, level and extent of underground water.
6. **COMPLIANCE WITH LAWS:** The Contractor shall familiarize himself with the nature and extent of the specifications, site conditions, traffic and safety requirements, and shall fully comply with all local, state and federal laws, including all codes, ordinances, rules and regulations applicable to this Contract and the work to be done hereunder, which exist or which may be enacted later by governmental bodies having jurisdiction or authority for such enactment. The Contractor shall comply with all federal, state and local laws, rules and regulations of every kind and nature applicable to the performance of its Work hereunder, and shall hold the Town of Addison and the Engineer harmless therefrom.
7. **PERMITS, LICENSES. AND REGULATIONS:** Permits and licenses for the prosecution of the Work shall be secured and paid for by the Contractor. Wherever the work under this contract requires the obtaining of permits from the Town of Addison or other public authorities, duplicate copies of such permits shall be furnished to the Engineer by the Contractor hereunder before the work covered thereby is started. **NO WORK WILL BE ALLOWED TO PROCEED BEFORE SUCH PERMITS ARE OBTAINED.**
8. **RIGHTS-OF-WAY AND EASEMENTS:** No right-of-way acquisition or easements are required for this project. However, when working within the public rights-of-way and easements, the Contractor shall at all times observe and comply with all Federal and State Laws, and Town of Addison ordinances and regulations which in any way affect the conduct of the work or his operations, and shall observe and comply with all orders, laws, ordinances and regulations which exist or which may be enacted later by bodies having jurisdiction or authority for such enactment. No plea of misunderstanding or ignorance thereof will be considered. The Contractor and his Sureties shall indemnify and save harmless the Town of Addison, the Engineer and all of their officers, agents, and employees against any and all claims or liability arising from or based on the violation of any such law, ordinance, regulation, or order, whether it be by himself or his employees.

There shall be no work performed on private property. If necessary, it shall be the responsibility of the Contractor, prior to the initiation of construction on easements through private property, to inform the property owner of his intent to begin construction. Before beginning construction in areas of public dedication, the Contractor shall inform the agency having jurisdiction in the area forty-eight (48) hours prior to initiation of the Work. All easements and property shall be cleaned up after use and restored to their original conditions or better.

9. **RESTRICTED WORK HOURS:** Construction may only occur from 7 a.m. to 7 p.m. Monday through Friday and from 8 a.m. to 7 p.m. on Saturdays. No work shall occur on Sundays. It is in the interest of the public safety and convenience for the work under this project to occur within the standard work hours. As a submittal, the Contractor must present a detailed work schedule to the Town for approval prior to construction.
10. **COMPLIANCE WITH IMMIGRATION LAWS:** Contractor shall take all steps necessary to ensure that all of the Contractor's employees are authorized to work in the United States as required by the Immigration Reform and Control Act of 1986.
11. **NON-DISCRIMINATION POLICY:** It is the policy of the Town of Addison to afford all people an equal opportunity to bid on any contract being let by the Town. The Town of Addison has a policy that prohibits discrimination against any person because of race, color, sex, or national origin, in the award or performance of any contract. The Town of Addison will require its employees, agents, and Contractors to adhere to this policy.
12. **ANTITRUST LAWS:** The Contractor hereby assigns to the Town of Addison any and all claims for overcharges associated with this contract which arise under the antitrust laws of the United States 15 U.S.C.A. Sec. 1, et seq. (1973).
13. **ABANDONMENT:** The Town of Addison reserves the right to abandon, without obligation to the Contractor, any part of the project, or the entire project, at any time before the Contractor begins any construction work authorized by the Town of Addison. In case of total abandonment of the project, the contract becomes void. The Town of Addison may abandon portions of the project at any time during the project duration. In case of such partial abandonment, the Contractor shall not be due any payment for lost or unrealized profits on the abandoned portions of the project.
14. **DISCREPANCIES:** If the Contractor, in the course of the Work, finds any discrepancy between the Contract Documents and the physical conditions of the locality, or any errors or omissions in drawings or in the layout as given by survey points and instructions, or if it appears that any Plan, Specification or other Contract Document is or may not be in compliance with any building code or other requirement of any governmental body, he shall immediately inform the Town of Addison and the Engineer in writing, and the Town of Addison and the Engineer shall promptly verify the same. Any Work done after such discovery, until authorized, will be done at the Contractor's risk.

15. **PREPARATION OF STORM WATER POLLUTION PREVENTION PLAN:** A Storm Water Pollution Prevention Plan (SW3P) will be prepared by the Contractor in accordance with the Texas Pollution Discharge Elimination System, General Permit Number TXR150000 relating to Discharges from Construction Activities issued by the Texas Commission on Environmental Quality (TCEQ). The SW3P will include the following information as required by the TCEQ Permit: Project description that includes: description of the construction activities, intended schedule or sequence of major soil disturbing activities, number of total acres of the project area and number of acres where soil will be disturbed, estimate of the runoff coefficient of the site for pre-construction and post-construction conditions, data describing the soil, a general location map, the name of receiving waters at or near the site, and a copy of the TPDES General Permit.

A Best Management Plan is provided in the plans with minimum elements for perspective Bidders. The contractor is required to prepare a detailed site map will be prepared showing drainage patterns and approximate slopes after grading, areas where soil disturbance will occur, locations of major structural controls, locations where stabilization practices are expected to be used, surface waters, and locations where storm water discharges from the site directly to a surface water.

The Contractor shall prepare a SW3P and submit a Notice of Intent (NOI) as required by the TPDES Permit if the total disturbed area is 5 acres or more.

A three-ring SW3P binder will be prepared containing all information and reports that are required as part of the SW3P. The Contractor will be required to prepare and utilize the SW3P as listed above, and maintain all records on-site during the project including performing inspections and maintaining all required documentation required by the TPDES General Permit.

This specification is not all inclusive of the requirements for an SW3P. The Contractor shall comply with all requirements of the TCEQ TPDES permit and the local authorities' storm water ordinance and/or regulations.

The SW3P plan provided by the Contractor shall be designed, signed, and sealed by a professional engineer registered in Texas.

16. **ADDENDA:** Bidders desiring further information, or interpretation of the Plans and Specifications, must make written request for such information to the Engineer (not later than three (3) working days prior to the date set for the Bid opening. The ability to ask questions will close at **2:00 pm, May 19, 2016**. Answers to all such requests will be issued in the form of Addenda and a copy of such Addenda will be released through www.bidsync.com. It will be the responsibility of each person who has been issued as set of Bidding Documents to secure all Addenda from www.bidsync.com. Addenda will be bound with and made a part of the Contract Documents. No other explanation or interpretation will be considered official or binding. Should a Bidder find discrepancies in, or omissions from, the Plans, Specifications or Contract Documents, or should he be in doubt as to their meaning, he shall at once notify the Engineer in writing in order that a written addendum may be sent to all Bidders.

17. **PAY ITEMS:** Pay items provided are intended to be all-inclusive of the work required on this project. Work required by the plans or specifications but not provided with a specific pay item shall be considered incidental to other items of work. Final payment to the construction Contractor shall not be made until all Work has been finally completed and verified in accordance with the construction contract, plans and specifications and have been finally accepted by the Town of Addison.

See Special Provisions 98. Bid Item Descriptions for reference specifications, plans, and details.

18. **INCREASE OR DECREASE IN QUANTITIES:** The quantities shown in the proposal are approximate. Final payment will be based on quantities determined by measurement methods described for each work item.

When the quantity of work to be done or materials to be furnished under any major pay item or contract is more than 125% of the quantity stated in the contract, whether stated by Town of Addison or by Contractor, then either party to the contract, upon demand, shall be entitled to negotiate for revised consideration on the portion of work above 125% of the quantity stated in the contract.

When the quantity of the work to be done or materials to be furnished under any major pay item of the contract is less than 75% of the quantity stated in the contract, whether stated by Town of Addison or by Contractor, then either party to the contract, upon demand, shall be entitled to negotiate for revised consideration on the portion of work below 75% of the quantity stated in the contract. This paragraph shall not apply in the event Town of Addison deletes a pay item in its entirety from this contract.

19. **SUBSIDIARY WORK:** Any and all work specifically governed by documentary requirements for the project, such as conditions imposed by the Plans or these Special Provisions, in which no specific item for bid has been provided for in the Proposal, shall be considered as a subsidiary item of work, the cost of which shall be included in the various bid items in the Proposal. Costs of permits, inspection fees, traffic control, construction staking, surface restoration and cleanup are general items of work which fall in the category of subsidiary work. Any repairs or replacement of items damaged during demolition or as a result of new construction will be considered subsidiary. Limits of all work requiring repair will be determined by the Town of Addison staff or the inspector. Extreme care should be taken during all demolition and construction operations.

20. **QUALIFICATION OF BIDS:** The Town of Addison reserves the right to reject any and all Bids, to waive any and all informalities not involving price, time or changes in the Work, and the right to disregard all nonconforming, non-responsive, unbalanced, or conditional Bids. The Town reserves the right to reject the Bid of any Bidder if the Town believes that it would not be in the best interest of the Project to make an award to that Bidder, whether because the Bid is not responsive or the Bidder is unqualified or of doubtful financial ability or fails to meet any other pertinent standard or criteria established by the Town. Discrepancies in the multiplication of units of Work and unit prices will be resolved in favor

of the unit prices. Discrepancies between the indicated sum of any column of figures and the correct sum thereof will be resolve in favor of the correct sum.

To be considered responsive, the apparent three lowest bidders are required to submit the Statement of Experience per Spec 00 45 16 within 5 days.

The apparent low three bidders will be notified by the Engineer to request the information.

- 21. AWARD AND EXECUTION OF CONTRACT:** For the purpose of award, each bid submitted shall consist of two parts whereby the correct summation of the products of the estimated quantities shown in the proposal, multiplied by their bid unit prices for the following parts:

- **Base Bid – Parts 001 thru 209**

The method of Award will be as shown below:

Award = Total Base Bid

The Town reserves the right to accept whichever bid is determined to be in the best interest of the public and to reject all bids.

All payments will be based on actual quantities and bid unit prices.

- 22. EXPLANATION OF CONTRACT TIME:** The term "Contract Time" as used in this Provision will mean the 210 calendar days for completion of the work of the Contract from the date the Contract was executed. The term "calendar day" as used in this Article will mean every day shown on the calendar. Calendar days will be consecutively counted from commencement of Contract Time regardless of weather, weekends, holidays, suspensions of Contractor's operations, delays or other events as described herein.

In the event of a catastrophic event (i.e., war, invasion, riot, declared state of emergency, national strike, or other situations as declared by the Town of Addison) directly and substantially affecting the Contractor's operations on the Contract, the Contractor and the Town shall agree as to the number of calendar days to extend the Contract Time. In the event the Contractor and Town are unable to agree to the number of calendar days to extend the Contract Time, the Town shall unilaterally determine the number of calendar days to extend the Contract Time reasonably necessary and due solely to such catastrophic event and the Contractor shall have no right whatsoever to contest such determination, save and except that the Contractor establishes that the number of calendar days determined by the Town were arbitrary or without any reasonable basis.

Should the Contractor fail to complete the Contract on or before expiration of the Allowable Contract Time, as adjusted in accordance with the provisions above, the Town shall deduct from the moneys due the Contractor the Liquidated Damages as shown in provision 95 for each calendar day completion exceeds the Allowable Contract Time. The term "Allowable Contract Time" as used in this Article shall mean the Original Contract Time plus

adjustments pursuant to the statements above. This deduction shall be the disincentive for the Contractor's failing to timely complete the Contract. **This shall be strictly enforced.**

23. **COPIES OF PLANS FURNISHED:** One (1) copy of 11" x 17" and one (1) electronic copy of the plans shall be furnished to the successful Contractor, at no charge, for construction purposes. Additional copies may be obtained at cost of \$150.00 per set upon request.
24. **PRE-CONSTRUCTION CONFERENCE:** The successful Contractor, Engineer, and Town of Addison shall meet for a pre-construction conference before any of the work begins on this project. At this time, details of sequencing of the work, contact individuals for each party, testing requirements, submittals, and pay requests will be covered. Prior to the meeting, the Contractor shall prepare schedules showing the sequencing and progress of their work and its effect on others. A final composite schedule will be prepared during this conference to allow an orderly sequence of project construction.
25. **MOBILIZATION:** The work specified in this item consists of the preparatory work and operations in mobilizing for beginning work on the project, including, but not limited to, those operations necessary for the movement of personnel, equipment, supplies and incidentals to the project site, and for the establishment of temporary offices, utilities, and other facilities, if necessary, for the construction of proposed improvements. The provisions of TxDOT Standard Specification Item (TxDOT Item) 500 "Mobilization" shall apply, except the maximum amount allowed will be 5% of the total bid amount.
26. **GENERAL SEQUENCE OF CONSTRUCTION:** Prior to the start of work, the Contractor shall develop a detailed construction and sequence of construction schedule using the critical path method (CPM) and submit to the Town of Addison for approval. The CPM shall reflect all definable features of work and activities that shall cause minimum interference with traffic along, across and adjacent to the project during construction. If the schedule or sequence becomes unworkable or unsatisfactory as work proceeds, adjustments shall be made. During all phases of construction access to all existing residences and businesses must be maintained at all times unless otherwise authorized in writing by the Town of Addison. Erosion control devices must be properly installed and maintained during all stages of construction.

The Contractor must comply with all lane closure and traffic movement restrictions as indicated in the plans unless specifically authorized in writing by the Town of Addison.

The general intent is for the contractor to begin at one end and steadily progress limiting the area of construction to minimize disruptions to the traveling public, residences and businesses along the route.

27. **PROJECT REPRESENTATIVE:** The Town of Addison, the Engineer, the Contractor(s), and any applicable public utilities shall designate a single individual within their organization to act as liaison for the project. This individual shall be aware of the day to day activities on the project, have authority to make decisions binding on the party, and serve as single point

for coordination of activities with the other team members. The Contractor's representative must be available to meet and discuss construction related issues on site or at the Town's offices within 20 minutes of a request during working hours and throughout the entire construction period. Upon repeated failure of attendance at requested meetings, Contractor will be required to have a project representative on-site at all times.

28. COORDINATION WITH OTHERS: In the event that other Contractors are doing work in the same area simultaneously with this project, the Contractor shall coordinate his proposed construction with that of the other Contractors. The Town of Addison and/or the Engineer shall mediate any disputes, and the Contractors shall comply with their decisions.

29. INSURANCE/INDEMNIFICATION

Attached as separate documents are the required insurance and indemnification forms. These forms must be signed and included in the bid.

Each insurance policy that the Contractor must furnish in accordance with these contract documents shall name the Town of Addison and the Engineer as additional insured. Contractor shall include in their bid package, a copy of their certificate of insurance showing compliance to the limits established by the Town of Addison.

1.0 The Contractor shall agree to furnish and maintain continuously during the period of this agreement, any renewals or extension, insurance coverage meeting all of the following requirements:

1.1 Commercial General Liability Insurance at minimum combined single limits of \$1,000,000 per occurrence and \$2,000,000 general aggregate for Bodily Injury and Property Damage, which coverage shall include Products/Completed Operations, and XCU Hazards. Coverage for product/completed operations must be maintained for at least two (2) years after the construction work has been completed. Coverage must be amended to provide for an each-project aggregate limit of insurance. Contractual Liability must be included.

1.2 Workers Compensation Insurance at statutory limits, including employer's liability coverage at minimum limits of \$1,000,000 each occurrence-each accident, \$1,000,000 by disease-each occurrence and \$1,000,000 by disease aggregate

1.3 Commercial Automobile Liability Insurance at minimum combined single limits of \$1,000,000 per occurrence for bodily injury and property damage, including owned, non-owned, and hired car coverage.

1.4 Umbrella Liability at minimum limits of \$1,000,000 each-occurrence \$4,000,000 aggregate with respect to primary commercial general liability, automobile liability and employer's liability policies.

1.5 Any Subcontractor(s) hired by the Contractor shall maintain insurance coverage equal to that required by the Contractor. It is the responsibility of the Contractor to assure compliance with this provision. The Town accepts no responsibility arising from the conduct, or lack of conduct, of the Subcontractor.

1.6 A comprehensive general liability insurance form may be used in lieu of a commercial general liability form. In this event, coverage must be written on an occurrence basis, at limits of \$1,000,000 each-occurrence, combined single limit and coverage must include a broad form comprehensive general liability endorsement, products/completed operations, XCU hazards and contractual liability.

2.0 With reference to the foregoing insurance requirements, Contractor shall specifically endorse applicable insurance policies as follows:

2.1 The Town shall be named as an additional insured with respect to general liability and automobile liability.

2.2 All liability policies shall contain no cross liability exclusions or insured versus insured restrictions.

2.3 A waiver of subrogation in favor of the Town of Addison shall be contained in the workers compensation and all liability policies.

2.4 All insurance policies shall be endorsed to require the insured to immediately notify the Town of Addison of any material changes in the insurance coverage.

2.5 All insurance policies shall be endorsed to the effect that the Town will receive at least thirty (30) days notice prior to cancellation or non-renewal of the insurance.

2.6 All certificates shall be mailed to Town of Addison, Purchasing Dept., P.O. Box 9010, Addison, Texas 75001 or emailed to purchasing@addisontx.gov.

2.7 All insurance policies, which name the Town as an additional insured, must be endorsed to read as primary coverage regardless of the application of other insurance.

2.8 Required limits may be satisfied by any combination of primary and umbrella liability insurances.

2.9 Contractor may maintain reasonable and customary deductibles, subject to approval by the Town.

3.0 All insurance shall be purchased from an insurance company who meets the following requirements:

3.1 Must be issued by a carrier, which is rated "A-" VII or better by A.M. Best's Key Rating Guide.

3.2 Licensed and admitted to do business in the State of Texas and is a subscriber to the Texas Guaranty Fund.

4.0 All insurance must be written on forms filed with and approved by the Texas State Board of Insurance. Certificates of insurance shall be prepared and executed by the

insurance company or its authorized agent and shall contain provisions representing and warranting the following:

4.1 Set forth all endorsements and insurance coverages according to requirements and instruction contained herein.

4.2 Shall specifically set forth the notice-of-cancellation or termination provisions to the Town.

5.0 Upon request, Contractor shall furnish the Town of Addison with certified copies of all insurance policies.

30. WORKERS' COMPENSATION INSURANCE COVERAGE:

A. Definitions.

Certificate of Coverage ("certificate") - A copy of a certificate of insurance, a certificate of authority to self insure issued by the Texas Workers' Compensation Commission (the "TWCC"), or a coverage agreement (TWCC-81, TWCC-82, TWCC-83 or TWCC-84), showing statutory workers' compensation insurance coverage for the person's or entity's employees providing services on a project, for the duration of the project.

Duration of the Project - includes the time from the beginning of the work on the project until the Contractor's/person's work on the project has been completed and accepted by the governmental entity.

Persons Providing Services on the Project ("Subcontractor" in Section 406.096 of the Texas Labor Code) - includes all persons or entities performing all or part of the services the Contractor has undertaken to perform on the project, regardless of whether that person contracted directly with the Contractor and regardless of whether that person has employees. This includes, without limitation, independent Contractors, Subcontractors, leasing companies, motor carriers, Town-operators, employees of any such entity or employees of any entity which furnishes persons to provide services on the project. "Services" include, without limitation, providing, hauling, or delivering equipment or materials, or providing labor, transportation, or other service related to a project. "Services" does not include activities unrelated to the project, such as food/beverage vendors, office supply deliveries, and delivery of portable toilets.

B. The Contractor shall provide coverage, based on property reporting of classification codes and payroll amounts and filing of any coverage agreement, which meets the statutory requirements of Texas Labor Code, 401.011(44) for all employees of the Contractor providing services on the project, for the duration of the project.

C. The Contractor must provide a certificate of coverage to the Town of Addison prior to being awarded the contract.

D. If the coverage period shown on the Contractor's current certificate of coverage ends during the duration of the project, the Contractor must, prior to the end of the coverage period, file a new certificate of coverage with the Town of Addison, showing that the coverage has been extended.

E. The Contractor shall obtain from each person providing services on the project, and provide to the Town of Addison:

(1) a certificate of coverage, prior to that person beginning work on the project, so that the Town of Addison will have on file certificates of coverage showing coverage for all persons providing services on the project; and,

(2) no later than seven days after receipt by the Contractor, a new certificate of coverage showing extension of coverage, if the coverage period shown on the current certificate of coverage ends during the duration of the project;

F. The Contractor shall retain all required certificates of coverage on file for the duration of the project and for one year thereafter.

G. The Contractor shall notify the Town of Addison in writing by certified mail or personal delivery, within 10 days after the Contractor knew or should have known, of any change that materially affects the provision of coverage of any person providing services on the project.

H. The Contractor shall post on each project site a notice, in the text, form and manner prescribed by the TWCC, informing all persons providing services on the project that they are required to be covered, and stating how a person may verify current coverage and report failure to provide coverage.

I. The Contractor shall contractually require each person with whom it contracts to provide Services on a project to:

(1) provide coverage, based on proper reporting of classification codes and payroll amounts and filing of any coverage agreements, which meets the statutory requirements of Texas Labor Codes 401.011 (44) for all its employees providing services on the project, for the duration of the project;

(2) provide to the Contractor, prior to that person beginning work on the project, a certificate of coverage showing that coverage is being provided for all employees of the person providing services on the project, for the duration of the project;

(3) provide the Contractor, prior to the end of the coverage period, a new certificate of coverage showing extension of coverage, if the coverage period shown on the current certificate of coverage ends during the duration of the project;

(4) obtain from each person with whom it contracts, and provide to the Contractor;

- a. a certificate of coverage, prior to the other person beginning work on the project; and,
- b. a new certificate of coverage showing extension of the coverage period, prior to the end of the coverage period, if the coverage period shown on the current certificate of coverage ends during the duration of the project.

(5) retain all required certificates of coverage on file for the duration of the project and for one year thereafter;

(6) notify the Town of Addison in writing by certified mail or personal delivery, within 10 days after the person knew or should have known, of any change that materially affects the provision of coverage of any person providing services on the project; and

(7) contractually require each other person with whom it contracts to perform as required by paragraphs (1) - (7) with the certificate of coverage to be provided to the person for whom they are providing services.

J. By signing this contract or providing or causing to be provided a certificate of coverage, the Contractor is representing to the Town of Addison that all employees of the Contractor who will provide services on the project will be covered by worker's compensation coverage for the duration of the project, that the coverage will be based on proper reporting of classification codes and payroll amounts, and that all coverage agreements will be filed with the appropriate insurance carrier or, in the case of a self-insured, with the TWCC's Division of Self-Insurance Regulation. Providing false or misleading information may subject the Contractor to administrative penalties, criminal penalties, civil penalties or other civil actions.

K. The Contractor's failure to comply with any of these provisions is a breach of contract by the Contractor which entitles the Town of Addison to declare the contract void if the Contractor does not remedy the breach within ten days after receipt of notice of breach from the Town.

The following is the form of notice of workers' compensation coverage prescribed by the TWCC. Pursuant to Section 110.110 (d) (7), this notice must be printed with a title in at least 30-point bold type, and text in at least 19-point nominal type, and shall be in both English and Spanish and any other language common to the worker population.

REQUIRED WORKERS' COMPENSATION COVERAGE

"The law requires that each person working on this site or providing services related to this construction project must be covered by workers' compensation insurance. This includes persons providing, hauling or delivering equipment or materials, or providing labor or transportation or other service related to the project, regardless of the identity of their employer or status as an employee.

"Call the Texas Workers' Compensation Commission (TWCC) at (512) 440-3789 to receive further information on the legal requirements for coverage,

to verify whether your employer has provided the required coverage, or to report an employer's failure to provide coverage."

31. **CLEAN AIR ACT AND CLEAN WATER ACT:** Include in all construction contracts exceeding \$100,000, the following requirement: "Contractor is responsible for compliance with all applicable standards, orders, or requirements issued under Section 306 of the Clean Air Act, Section 505 of the Clean Water Act, Executive Order 11738, and Environmental Protection Agency regulations."
32. **RESOLUTION OF DISPUTES:** The parties hereby covenant and agree that in the event of any controversy, dispute, or claim, of whatever nature arising out of, in connection with or in relation to the interpretation, performance or breach of this agreement, including but not limited to any claims based on contract, tort or statute, before filing a lawsuit, the parties agree to submit the matter to Alternative Dispute Resolution pursuant to the laws of the State of Texas. The parties shall select a third party arbitrator or mediator from the current list of neutrals on file with the Alternative Dispute Resolution Administrator of the Dallas County District Courts. All forms of Alternative Dispute Resolution may be used except binding arbitration. The proceedings shall be conducted in accordance with the laws of the State of Texas.
33. **SHOP DRAWINGS:** The Contractor shall provide, review, approve and submit all shop drawings, product data and samples required by the Town of Addison, the Engineer and the Contract Documents in accordance with Item 1.28 of the Standard Specifications for Public Works Construction, North Central Texas Council of Governments. The Contractor shall furnish a minimum of four and a maximum of six copies of shop drawings for review by the Engineer, who will review, approve and forward to the Town of Addison for acceptance. Approved submittals will be returned as follows:

Two (2) – Town of Addison

One (1) – Contractor

Two (2) – Halff Associates

Maximum size of submittals shall be 11 x 17 inch. No fax copies are acceptable. Shop drawings shall include all items to be installed in the project, including:

- Concrete Mix Designs
- Irrigation Fittings & Appurtenances
- Dewatering Operation Site Layout
- Backfill Materials
- Bypass Pumping Layout
- Conduit
- Traffic Control Plan
- Construction Entrance Layout
- Finishes

34. **PROJECT VIDEO:** Prior to the start of construction, Contractor shall video the construction area and property adjacent to construction in the presence of the City Inspector. The format shall be DVD. The video shall be narrated. The Contractor shall furnish the Town of Addison a copy of the video in DVD format prior to commencement of project. This shall be subsidiary to project.

35. **SAMPLES AND TESTS OF MATERIALS:** The Contractor shall designate and pay an independent testing laboratory to furnish testing for this project. Random testing will be provided by the independent lab as necessary for compliance with the specifications. The Contractor shall coordinate construction with the testing lab and the Town of Addison, and shall provide assistance to the testing labs by providing excavation, access, trench safety, materials for testing and any other work required to insure all testing requirements are met. Work performed to accommodate testing will be a subsidiary item and no extra payment will be authorized. All costs for the field quality control testing shall be paid for by the Contractor, including any and all re-testing. As a guide, the Contractor shall be responsible for providing any test required by the specifications.

All samples and tests shall be performed in accordance with the Standard Specifications for Public Works Construction, North Central Texas Council of Governments (Latest Edition) as amended or supplemented. The Town of Addison may elect to have its own independent lab if it so desires.

36. **INSPECTION:** The Town of Addison and the Engineer reserve the right to inspect, test, measure or verify the construction work for this project as they deem necessary to ascertain that the Work is being accomplished in accordance with the standards and requirements set forth in the Contract Documents. Notwithstanding such reviews, the Contractor will be held responsible for the finished Work and any acceptance of the Work by the Town or governmental agencies will not relieve the Contractor from responsibility for the Work. The Town reserves the right to place full-time construction inspectors at the site of the Work. Costs for inspection services will be paid by the Town of Addison. The Contractor shall provide assistance to the Town of Addison and the Engineer by providing excavation, trench safety, or other work necessary to facilitate inspection activities, and shall give sufficient notice well in advance of pending construction activities for scheduling of inspection services.

If the Specifications, the Town's instructions, laws, ordinances, or any public authority require any Work to be specially tested, the Contractor shall give the Town timely notice (at least 48 hours) of its readiness for testing, and if the testing is by an authority other than the Town, of the date fixed for such testing. Tests by the Town shall be made promptly, and where practicable at the source of supply.

37. **ACCESS ROUTES, STAGING AREAS AND STORAGE AREAS:** All haul roads and access routes and the location of job site trailers, staging areas, and storage areas shall be subject to the approval of the Town and the Engineer. The Contractor shall be responsible for maintaining and repairing all roads and other facilities used during construction. Upon completion of the project all existing roads and other disturbed areas shall be left in a condition equal to that at the time the Contractor commences work on this project.
38. **PROPERTY ACCESS:** Access to adjacent properties shall be maintained at all times unless otherwise directed by the Engineer and/or Town of Addison. Contractor shall also

maintain sufficient access throughout the project limits to the existing buildings and businesses during construction operations.

39. **PLANT, PROCEDURES, METHODS AND EQUIPMENT:** The Contractor shall determine the methods to be employed, the procedures to be followed, and equipment to be used on the work under this contract, subject to the requirements of these specifications and approval of the Engineer and Town of Addison. Only adequate and safe procedures, methods and equipment shall be used.

The Contractor shall so arrange his work and provide such plant and equipment as is necessary in order to meet the progress requirements of the approved time schedule and to complete the work within the period of time as specified in the Construction Agreement. Only such materials and equipment as are necessary for the construction of the work under this contract shall be placed, stored or allowed to occupy any space at the site of the work.

It is expressly agreed that the acceptance or approval of any order of procedure, methods or equipment submitted or employed by the Contractor shall not in any manner relieve the Contractor of responsibility for the safety, maintenance and repairs of any work, or for the construction maintenance and safety of the work hereunder, or from any liability whatsoever on account of any procedure or method employed by the Contractor.

Where the work under this contract requires permits from the Town of Addison, the State of Texas, or other public authorities, duplicate copies of such permits shall be furnished to the Engineer by the Contractor before the work covered thereby is started. **NO WORK WILL BE ALLOWED TO PROCEED BEFORE REQUIRED PERMITS ARE OBTAINED AND DISTRIBUTED.**

40. **PARKING OF CONSTRUCTION EQUIPMENT:** At night and during all other periods of time when equipment is not being actively used on the construction work, the Contractor shall park the equipment at locations, within project limits, which are approved by the Town of Addison or the Engineer. The Contractor shall provide adequate barricades, markers and lights to protect the Town of Addison, the Engineer, the public and other work. All barricades, lights, and markers must meet the requirements of the Town of Addison, State and Federal regulations.
41. **ZONING REQUIREMENTS:** During the construction of this project, the Contractor shall comply with the present zoning requirements of the Town of Addison in the use of vacant property for storage purposes.
42. **CONSTRUCTION IN PUBLIC ROADS AND PRIVATE DRIVES:** No public road shall be entirely closed overnight. It shall be the responsibility of the Contractor to build and maintain all weather bypasses and detours, if necessary, and to properly light, barricade and mark all bypasses and detours that might be required on and across the roads involved in the work included in this contract. No interference with traffic flow on city streets shall be permitted during the hours of 6:30 a.m. to 9:30 a.m. and 3:30 p.m. to 7:30 p.m., Mondays

through Fridays.

The Contractor shall make every effort to complete construction and allow immediate access to adjacent property at driveway entrances located along the roadways. Towns or tenants of improvements where access and/or entrance drives are located shall be notified at least twenty-four (24) hours prior to the time the construction will be started at their driveways or entrances and informed as to the length of time driveways will be closed. Contractor shall at all times maintain at least one point of access into all properties, unless obtaining written permission from property Town to do otherwise with such written permission being provided to the Town's inspector.

The Contractor shall be responsible for all road and entrance reconstruction and repairs and maintenance of same for a period of two years from the date of such reconstruction. In the event the repairs and maintenance are not made immediately to the satisfaction of the Town, and it becomes necessary for the Town to make such repairs, the Contractor shall reimburse the Town for the cost of such repairs.

The Contractor shall, at all times, keep a sufficient width of the roadway clear of dirt and other material to allow the free flow of traffic. The Contractor shall assume any and all responsibility for damage, personal or otherwise, that may be caused by the construction along roads and private drives.

43. **HAULING ON TOWN OF ADDISON STREETS:** The Contractor shall receive approval of his haul routes and type of equipment to be used prior to beginning construction. The Contractor shall be responsible for maintaining the cleanliness of existing paved roadways and shall provide equipment and manpower for that purpose.
44. **EXISTING POWER POLES & GUY WIRES:** The Town has arranged to relocate one guy wire at the north side of Pond 3 with no cost to the Contractor. Beyond this single relocation, the Contractor shall have the responsibility of coordinating with the proper authorities for the bracing, replacing or relocating of all utility poles and guy wires which interfere with the construction of this project prior to beginning his construction operations. The Contractor will also be responsible for all damage to poles, guy wires, etc. that are damaged or destroyed by Contractor's operations.
45. **SAFETY RESTRICTIONS - WORK NEAR HIGH VOLTAGE LINES:** The following procedures shall be followed for work near high voltage lines on this contract:
 - a. A warning sign not less than five (5) inches by seven (7) inches, painted yellow with black letters that are legible at twelve (12) feet shall be placed inside and outside vehicles such as cranes, derricks, power shovels, drilling rigs, pile driver, hoisting equipment or similar apparatus. The warning sign shall read as follows: "Warning - Unlawful to Operate This Equipment Within Six Feet of High Voltage Lines."
 - b. Equipment that may be operated within ten (10) feet of high voltage lines shall have an insulating cage guard protecting the boom or arm, except backhoes or dippers, and insulator links on lift hook connections.

- c. When necessary to work within six (6) feet of high voltage electric lines, notify the power company who will erect temporary mechanical barriers, de-energize the line, or raise or lower the line. All such work done by the power company shall be at the expense of the Contractor. The Contractor shall maintain an accurate log of all such calls to the power company.
- d. The Contractor is required to make arrangements with the power company for the temporary relocation or raising of high voltage lines at the Contractor's sole expense.
- e. No person shall work within six (6) feet of high voltage lines without protection measures having been taken as outlined in Paragraph c.

46. **PROTECTION OF EXISTING UTILITIES AND STRUCTURES:** The location and dimensions shown on the plans relative to existing utilities and subsurface structures are based on the best records and/or field information available and are not guaranteed by the Town of Addison or the Engineer to be accurate as to location and depth. It shall be the Contractor's responsibility to verify locations of adjacent and conflicting utilities sufficiently in advance of his activities in order that he may negotiate such restrictive locations with the Town of Addison of the conflicting utility and/or make local adjustments to provide adequate clearances. The Contractor shall take all necessary precautions in order to protect all utilities and services encountered, whether or not they are indicated on the plans. All damage to utilities resulting from Contractor's operations shall be restored at his expense. The Town of Addison and the Engineer assume no responsibility for failure to show any or all of these utilities or structures on the plans, or to show them in their exact locations. It is mutually agreed that such failure shall not be considered sufficient basis for claims for additional compensation for extra work or for increasing the pay quantities in any manner whatsoever, unless the obstruction encountered is such as to necessitate changes in the lines or grades, or requires the building of special work, provisions for which are not made in the plans, in which case, provisions in these specifications for extra work shall apply.

47. **PUBLIC UTILITIES AND OTHER PROPERTY TO BE CHANGED:** In case it is necessary to change or move the property of a public utility, such property shall not be moved or interfered with until authorized by the Town of Addison or the Engineer. The right is reserved for the Owner of public utilities to enter upon the limits of the project for the purpose of making such changes or repairs of their property that may be made necessary by performance of the Contract. The Contractor shall be responsible for coordination with the Town of Addison and the Engineer, and all utility companies whose utility lines or streets may be affected by the proposed improvements. The Contractor shall observe the following:

- a. Prior to any excavation, the Contractor shall determine the locations of all existing water, gas, sewer, electric, telephone, telegraph, television, pipelines and other underground utilities and structures.
- b. After commencing work, the Contractor shall use every precaution to avoid interference with existing underground and surface utilities and structures, and protect them from damage.

- c. Where the locations of existing underground and surface utilities and structures are indicated, these locations are generally approximate, and all items which may be encountered during the work are not necessarily indicated. The Contractor shall determine the exact locations of all items indicated, and the existence and locations of all items not indicated.
 - d. The Contractor shall repair or pay for all damage caused by his operations to all existing utility lines, public property, and private property, whether it is below ground or above ground, and he shall settle in total the cost of all damage suites which may arise as a result of his operations.
 - e. To avoid unnecessary interferences or delays, the Contractor shall coordinate all utility removals, replacements and construction with the appropriate utility company, and then request written authorization from the Town of Addison or the Engineer. The Town of Addison and the Engineer will not be liable for damages due to delay as a result of the above.
48. **MAINTENANCE AND REPAIRS:** The Contractor shall maintain and keep in good repair all work contemplated under these plans, specifications, and drawings which shall include the maintenance and repair of all existing streets, storm sewer crossings, utility crossings, temporary crossings for access to adjacent property, barricades, lights, and danger signals, and all work which is necessary for the well being of the general public. In the event the Contractor fails in his obligations to properly maintain the work, the Town of Addison shall make such repairs as are necessary and the cost of such repairs shall be deducted from payment due the Contractor.
49. **PROTECTION OF WORK:** During performance and up to date of final acceptance, the Contractor shall be under the absolute obligation to protect the finished work against damage, loss or injury. In the event of damage, loss or injury, the Contractor shall promptly replace or repair such work, whichever the Town of Addison shall determine to be preferable. The obligation to deliver finished work in strict accordance with the contract prior to final acceptance shall be absolute and shall not be affected by the Town of Addison's approval of or failure to prohibit means and methods of construction used by the Contractor. All risk of loss or damage to the work shall be borne solely by the Contractor until final acceptance of all work by the Town of Addison, as evidenced by the Town of Addison's issuance of a certificate of acceptance.
50. **PUBLIC CONVENIENCE AND SAFETY:** In accordance with generally accepted construction practices, the Contractor shall be solely and completely responsible for conditions of the job site, including safety of all persons and property during performance of the work. This requirement shall apply continuously and not be limited to normal working hours.

Materials stored about the work site shall be so placed, and the work shall at all times be so conducted, as to cause no greater obstruction to the traveling public than is considered

necessary by the Town of Addison. The materials excavated shall be placed so as not to endanger the work or prevent free access to all fire hydrants, water valves, gas valves, manholes (telephone, telegraph or electrical conduits, and sanitary sewers) and fire alarm or police call boxes in the vicinity.

The Town of Addison reserves the right to remedy any neglect on the part of the Contractor as regards to the public convenience and safety which may come to the Town of Addison's attention, after 24 hours notice in writing to the Contractor, save in cases of emergency, when the Town of Addison shall have the right to remedy any neglect without notice; and, in either case, the cost of such work done by the Town of Addison shall be deducted from the monies due or to become due the Contractor. The Contractor shall notify the Town of Addison and the Engineer when any street is to be closed or obstructed. The Contractor shall provide for emergency vehicle access at all times.

The Contractor, material, and equipment shall stay within the project limits. The Contractor shall notify the proper representatives of any public utility, corporation, company or individual, not less than 48 hours in advance of work which might damage or interfere with the operation of their property along or adjacent to the work. The Contractor shall be responsible for all damage or injury to property of any character (except such as may be required by the provisions of the Contract Documents, or caused by agents or employees or the Town of Addison) by reason of any negligent act or omission on the part of the Contractor, his employees, agents or Subcontractors, or at any time due to defective work or materials, or due to his failure to reasonably or properly prosecute the work, and said responsibility shall not be released by the fact that the work shall have been completed and accepted.

When and where any such damage or injury is done to public or private property on the part of the Contractor, he shall restore or have restored at his own cost and expense such property to a condition similar or equal to that existing before such damage was done, by repairing, rebuilding or otherwise restoring as he may be directed, or he shall make good such damage or injury in a manner acceptable to the property Town of Addison and the Engineer. In case of failure on the part of the Contractor to restore such property or make good such damage or injury, the Town of Addison may, upon 48 hour written notice under ordinary circumstances, and without notice when a nuisance or hazardous condition results, proceed to repair, rebuild or otherwise restore such property as may be determined necessary, and the cost thereof shall be deducted from any monies due or to become due to the Contractor under this contract; or where sufficient contract funds are unavailable for this purpose, the Contractor or his surety shall reimburse the Town of Addison for all such costs.

51. **PROTECTION OF PERSONS AND PROPERTY:** The Contractor shall have the responsibility to provide and maintain all warning devices and take all precautionary measures required by law or otherwise necessary to protect persons and property while said persons or property are approaching, leaving or within the work site or any area adjacent to said work site. No separate compensation shall be paid to the Contractor for the installation or maintenance of any warning devices, barricades, lights, signs, or any other precautionary measures required by law or otherwise necessary for the protection of persons or property.

The Contractor shall assume all responsibilities to the general public in connection with the general public's immediate approach to and travel through the work site and the area adjacent to said work site.

Where the work is in or adjacent to any street, alley, sidewalk, public right-of-way or public place, the Contractor shall at his own cost and expense provide such flagmen and watchmen and furnish, erect and maintain such warning devices, barricades, lights, signs, and other precautionary measures for the protection of persons or property as may be prudent or necessary, or as required by law. The Contractor's responsibility for providing and maintaining flagmen, watchmen, warning devices, barricades, signs and lights and other precautionary measures shall not cease until the project shall have been completed and accepted by the Town of Addison, and shall cease when the Town of Addison notifies the Contractor in writing of final project acceptance.

If the Town of Addison discovers that the Contractor has failed to comply with applicable federal or state laws (by failing to furnish the necessary flagmen, warning devices, barricades, lights, signs or other precautionary measures for the protection of persons or property), the Town of Addison may order the Contractor to take such additional precautionary measures as required by law to protect persons and property. In addition, the Contractor shall be held responsible for all damages to the work and other public or private property due to the failure of warning devices, barricades, signs, lights or other precautionary measures in protecting said property; and whenever evidence is found of such damage, the Town of Addison may order the damaged portion immediately removed and replaced by and at the cost and expense of the Contractor.

- 52. TRAFFIC CONTROL:** It shall be the responsibility of the Contractor to provide traffic control during the construction as required by the State of Texas, the Town of Addison, and in accordance with the following additional requirements:
- a. The Contractor shall be required to furnish barricades, flares, flagmen, etc., for the protection of the public, employees and the work.
 - b. The Contractor shall prosecute his work in such a manner as to create a minimum of interruption to traffic along adjacent roadways.
 - c. The unit price bid under the appropriate bid item of the proposal shall cover all cost for providing signage, markings, lighting, barricades, flagmen and other devices and personnel required for traffic control during construction of the project.
 - d. The Contractor shall not remove any regulatory sign, instructional sign, warning sign, street name sign or any other sign or signal which currently exists.
 - e. The Contractor shall provide a comprehensive Traffic Control Plan to the Town of Addison and Engineer for review, comment, and approval in the event the planned sequence of work is different in any way from that sequence of work provided for in the plans or where additional details are required. The Traffic Control Plan shall be designed in accordance with established standards and regulations and signed and sealed by a

professional engineer, registered in the State of Texas. The comprehensive plan shall reflect the Contractor's proposed construction phasing and methodology and include the design layout for all proposed detour and traffic situations.

53. **BARRICADES, WARNING SIGNS, DETOURS AND SEQUENCE OF CONSTRUCTION:** Throughout the construction operations, streets and intersections will remain open to traffic by constructing the work in stages. All streets, driveways, adjacent business and alleys shall remain open to traffic as far as is practicable.

A. General Construction: The Contractor shall plan his work sequence in a manner that will cause minimum interference with traffic during construction operations. Before beginning work on this project, the Contractor shall submit, for approval by the Town of Addison, a plan of construction operations outlining in detail a sequence of work to be followed; setting out the method of handling traffic on streets, roads and driveways along, across and adjacent to the work. If at any time during the construction, the Contractor's proposed plan of operation for handling traffic does not provide for safe comfortable movement, the Contractor shall immediately change his operations to correct the unsatisfactory conditions.

Ditches across the traffic lanes will be kept covered with a portable traffic-bearing surface at all times unless work in the ditch is in progress. Only one lane of traffic may be closed at a time when work is in progress in a ditch.

B. Safety: The Contractor shall provide, construct and maintain barricades and signs at locations set out in the plans and in the Special Provisions in accordance with the Texas Manual on "Uniform Traffic Control Devices for Streets and Highways". In addition, he shall provide and maintain such other barricades and signs as deemed necessary by the Town or the Engineer, and provide and maintain, between sunset and sunrise, a sufficient number of lights at barricades and points of danger for the protection of vehicular and pedestrian traffic.

Barricades shall be placed in such a manner as not to interfere with the sight distance of drivers entering the street from side streets.

The Contractor shall keep traveled surfaces used in his hauling operation clear and free of dirt, mud, silt, or other material.

The Contractor shall provide and maintain qualified flagmen at such points and for such periods of time as may be required to provide for the safety and convenience of public travel and Contractor's personnel.

54. **EXCAVATION SAFETY SYSTEMS**

The work performed under this section of the specifications consists of providing trench safety systems consisting of shoring, sheeting, trench shield, and/or laid back slopes to meet the trench safety requirements of the Occupational Safety and Health Administration (O.S.H.A.), as required for this project and specified herein.

A. General: Trench safety systems shall be provided by the Contractor as provided in Subpart P - Excavation, Trenching and Shoring, Part 1926 of the Code of Federal Regulations which describes safety and health regulations as administered by the U.S. Department of Labor Occupational Safety and Health Administration (O.S.H.A.). The standards specified by the O.S.H.A. Regulations shall be the minimum allowed on this project. It shall be the responsibility of the Contractor to design and install adequate trench safety systems for all trenches excavated on this project.

The Contractor shall furnish to the Town for review, prior to beginning construction activity, a Trench Safety Plan for the entire project. The trench safety plan must be prepared and sealed by a Professional Engineer registered in the State of Texas. In addition, all trench safety systems utilized in this project must be designed by a Professional Engineer registered in the State of Texas. The Contractor shall be totally responsible for the safety of all persons involved in the construction of this project.

B. Core Borings: Any core borings and soil data furnished by the Town are for the convenience of the Contractor. The Contractor shall be responsible for any additional soil or geotechnical information required. The Contractor shall be responsible for properly designed trench safety systems to be utilized for any type of subsurface condition found on this project. The furnishing of soil information by the Town of Addison in no way relieves the Contractor of this obligation. If no core borings or soil data are furnished by the Town, it shall be the Contractor's responsibility to obtain whatever geotechnical information required for preparation of trench safety systems.

C. Inspections: In addition to the inspections of the trench and trench safety systems required of the Contractor by the O.S.H.A. Regulations, the Town may further inspect the work. The Town shall have the right to reject any trench safety systems which he finds to be inadequate, and the Contractor shall immediately improve the system to comply with this specification.

D. Measurement and Payment: Measurement and payment of Trench Safety Systems shall be based on lump sum for the entire project. The payment shall be full compensation for all planning, engineering, materials, equipment, fabrications, installation, recovery and all incidental work required. All excavation and backfill in addition to that specified elsewhere in these specifications shall be considered subsidiary to this bid item.

55. TRENCH EXCAVATION, BACKFILL AND COMPACTION: Trench excavation, backfill and compaction of storm drain and utility trenches shall be in accordance with Town of Addison Standards and with details shown on the Construction Drawings.

A. Trench Excavation: If the stated maximum trench widths are exceeded, either through accident or otherwise, and if the Engineer determines that the design loadings of the pipe will be exceeded, the Contractor will be required to support the pipe with an improved trench bottom. The expense of such remedial measures shall be entirely the Contractor's own. All trenching operations shall be confined to the width of permanent rights-of-way, permanent

easements and any temporary construction easements. All excavation shall be in strict compliance with the Trench Safety Systems Special Conditions of this document.

B. **Trench Backfill:** Trenches shall be backfilled above the top of the embedment material with approved backfill material per Town of Addison Standards for the appropriate pipe size, pipe material, depth, and soil condition. NCTCOG, Type B backfill, item 504.2.3.3 or native material meeting the requirements of Type B backfill are considered the minimum requirement.

C. **Flowable Fill Concrete:** Trenches in the pond bottom shall be backfilled to the pond bottom elevation with approved flowable fill concrete per Town of Addison Standards and NCTCOG item 504.2.3.4.

D. **Compaction:** All trenches under proposed or existing pavement shall be compacted to within a range of 95% to 100% Standard Proctor Density. Trenches which lie outside limits of pavement shall be compacted to a minimum of 90% Standard Proctor Density (ASTM D-698).

56. **TRENCH WALLS:** The Contractor shall use shoring or a drag box in those areas where it is required to protect existing improvements. This shall be subsidiary to the linear foot cost of the pipe and not a separate pay item.
57. **PROPERTY LINES AND MONUMENTS:** The Contractor shall protect all property corner markers, and when any such markers or monuments are in danger of being disturbed, they shall be properly referenced and if disturbed shall be reset at expense of the Contractor.
58. **CONSTRUCTION STAKING:** Construction staking will not be provided by the Town of Addison or Engineer. This item will be performed by the Contractor and shall be subsidiary to other bid items. The Contractor will also be responsible for maintaining stakes. If re-staking is required for any reason, it will be the Contractor's responsibility, including associated costs.

All construction staking shall be done under the supervision of a Registered Professional Land Surveyor registered in the State of Texas. The Contractor shall submit copies of cut sheets and field books for the construction of all paving, water, wastewater, and stormwater improvements to the Town of Addison for review prior to construction of the improvements. The information on the cut sheets and field books shall include but not be limited to the following:

- a. Heading to include date, contract number, project name, surveying firm, Contractor, and construction plan sheet number.
- b. Location, description of street/line and street/line name, number, letter, etc. designation.
- c. Benchmark Data: Location, description, and elevation.

- d. Slope or percent of grade of each curb line or utility line.
 - e. Stations at 50 foot intervals and including all PC, PT, PI, PVC, PVI, PVT, PRC, grade changes, etc.
 - f. Offset description including distance to center line or back of curb and direction of offset; left, right, east, west, etc,
 - g. Cut to subgrade, pavement, top of curb, or flowline of the street or utility being staked.
 - h. Clarifying remarks such as top of curb, gutter, pavement, subgrade, manhole, cleanout, valve, tee, cross, fire hydrant, wastewater lateral, water service, etc.
 - i. Cut sheets shall be signed by a Texas Registered Professional Land Surveyor.
59. **VENDOR'S CERTIFICATION:** All materials used in construction shall have a vendor's certified test report. Test reports shall be delivered to the Engineer before permission will be granted for use of the material. All vendors' test reports shall be subject to review by the Engineer, and shall be subject to verification by testing of samples of materials as received for use on the project. In the event additional tests are required, they shall be performed by an approved independent testing laboratory and shall be paid for by the Contractor.
60. **WATER PIPE:** All water mains twelve-inch (12") diameter and smaller shall be AWWA C-900 PVC pressure pipe with cast iron o.d. or when pipe penetrates meter vault walls it shall be ductile iron. Pipe joints shall be rubber ring and integral thickened bell, assembled with a factory supplied lubricant. Water mains shall have a minimum class rating of 165-psi for domestic use and a minimum class rating of 235-psi for fire line applications. Joint material for PVC shall conform to ASTM F471.
61. **WASTEWATER PIPE:** All wastewater main piping shall meet the extra strength requirements of ASTM specification D3034 (SDR-35). Pipe shall have the bell and spigot type joints, consisting of integral wall section with factory installed compression rubber ring gasket, securely locked in bell groove to provide positive seal under all installation conditions. Pipe shall be laid with the bell end on the upstream side.
62. **STORM DRAINAGE PIPE:** All pipe for storm drainage improvements shall be reinforced concrete pipe (RCP), Class III, unless otherwise noted on the plans.
63. **POLYETHYLENE WRAPPING:** All valves, ductile iron pipe, cast iron fittings, and specials, shall be polyethylene wrapped. Payment for the polyethylene wrapping for these components shall be subsidiary to the various items bid for the furnishing and installing pipe complete in place. Polyethylene wrap shall precede blocking.
64. **PIPE CLEANING:** Joints shall be wiped and then inspected for proper installation by the inspectors. Each joint shall be swept daily and kept clean during installation. A temporary night plug shall be installed on all exposed pipe ends during any period of work stoppage.

65. **PLUGS:** Pipe plugs for water and wastewater lines shall be considered incidental and shall not be a separate pay item. Plugs for storm drain lines do have separate pay items established for each size provided and shall be paid for accordingly.
66. **CEMENT STABILIZED BACKFILL:** Two (2) sack cement stabilized backfill shall be provided in wastewater pipe trenches at locations of crossings with water lines where shown on the plans and in conformance with Texas Commission on Environmental Quality (TCEQ) for Public Water Systems. Payment for such work including all labor, tools, equipment and material necessary to complete the work shall be included in the linear foot price bid for Cement Stabilized Backfill.
67. **NON-METALLIC WATER PIPE DETECTION:** Detectable underground utility warning tapes, which can be located from the surface by a pipe detector, shall be installed directly above non-metallic pipe. The detectable tape shall be “Detect Tape” as manufactured by Allen Systems, Inc. or an approved equal, and shall consist of a minimum thickness of 0.35-mil. Solid aluminum foil encased in a protective inert plastic jacket that is impervious to all known alkalis, acids, chemical reagents and solvents found in the soil. The minimum overall thickness of the tape shall be 5.5-mils. And the width shall not be less than two-inch with a medium unit weight of 2 ½ pounds per inch x 1,000 feet. The tape shall be color coded and imprinted with the messages as follow:

<u>Type of Utility</u>	<u>Color Coded</u>	<u>Legend</u>
Water	Safety Precaution Blue	CAUTION BURIED WATER LINE BELOW
Sanitary	Safety Green	CAUTION BURIED SEWER LINE BELOW

Installation of detectable tapes shall be per manufacturer’s recommendations, and shall be as close to the grade as is practical for optimum protection and detectability. Allow a minimum of 18 inches between the tape and the water line. Payment for detectable tapes shall be included in the linear foot price bid for applicable pipe(s).

68. **PIPE EMBEDMENT:** All storm drain and utility construction shall be installed with embedment per the Town of Addison Standard Details shown on the plans for the appropriate pipe size, pipe material, depth and soil condition unless otherwise directed by the Town of Addison or the Engineer.
69. **REMOVALS, ADJUSTMENTS AND REPLACEMENTS:** Existing pavements, driveways, curbs, gutters, sidewalks, etc., to be removed to facilitate the construction of the improvements shall be broken up and disposed of. Care shall be exercised to leave a neat, uniform edge or joint at the excavation limits or sections removed where only portions are to be removed. The Engineer will designate the limits to be removed. Where pavements, driveways, curbs, gutters, sidewalks, etc., shall be replaced, then said replacements shall be

to the standard of the previously removed portion or better. Re-sawing of damaged edges will be at the Contractor's expense.

Existing structures such as manholes, inlets, cleanouts, valve boxes, etc. which are not the property of a private firm or company, or an individual required to move their own property, shall be adjusted, altered or reset to the required elevation and alignment. New materials and workmanship necessary shall conform to the requirements of these Specifications covering the particular Work. Salvaged materials in good condition may be used in rebuilding such structures, provided the materials are thoroughly cleaned before their use. These items shall be subsidiary to other bid items unless quantified in the proposal as a separate bid item.

All private obstructions which are indicated on the Plans to be moved, will be removed and replaced, or moved to new permanent locations by the Contractor, without additional payment to the Contractor. Any such additional item which the Contractor moves or causes to be moved for his own convenience shall be at his own expense.

70. **PAVEMENT REPAIR:** The unit price bid under the appropriate bid item of the proposal shall cover all cost for providing pavement repair per the pavement repair detail provided in the plans.
71. **WATER FOR CONSTRUCTION:** The Contractor shall acquire a meter and make the necessary arrangements with the Town of Addison for securing and transporting all water required for construction, including water required for dewatering, mixing of concrete, sprinkling, testing or flushing. There will be no separate pay item for connection into the existing water system and quantity of water required for construction purposes. The Town of Addison will not furnish water for initial cleaning and sterilization of water lines. All additional water used by the Contractor for compaction or any other purpose incidental to this project may be obtained from existing hydrants along adjacent roadways. Note that the Contractor will be responsible for supplying chlorine gas or chlorinated lime (HTH) for water line sterilization.
72. **EXISTING STOCKPILES OF MATERIAL ON SITE:** There shall be no stockpiling of silt material on site.
73. **BORROW SOURCE:** If additional sources of earthen material are required for construction of embankment areas to complete the project to the alignment, grades and cross sections indicated on the plans, Contractor will be required to locate, obtain, excavate, deliver and place suitable fill material from an off-site source. Borrow materials should be compatible with existing on-site materials and shall be tested by the Geotechnical Engineer (employed and paid for by the Contractor) for acceptance as an approved source of borrow prior to borrow operations. Item 3.6 - Borrow of the Standard Specifications for Public Works Construction, North Central Texas Council of Governments shall apply for all work performed

74. **EXCESS MATERIAL:** Suitable excess material (if any) may not be disposed of on this site.

Tree stumps and limbs, concrete debris, discarded materials and all unsuitable excess spoil material, including rock measuring larger than 12" in the largest dimension, shall become the property of the Contractor and shall be removed from the site and disposed of by the Contractor at his expense. The Contractor shall also comply with all applicable laws governing spillage of debris while transporting to a disposal site, and shall indemnify and save harmless the Town of Addison and the Engineer from all suits, actions, or claims of any character resulting from his arrangements for the disposal of spoil.

75. **DURING CONSTRUCTION:** During construction of the work, the Contractor shall, at all times, keep the site of the work and adjacent premises as free from material, debris and rubbish as is practicable and shall remove same from any portion of the site if, in the opinion of the Town of Addison or the Engineer, such material, debris or rubbish constitutes a nuisance or is objectionable. In case of failure on the part of the Contractor to maintain a clean site, the Town of Addison may, upon 24 hour written notice, clean the site, and the cost thereof shall be deducted from any monies due or to become due to the Contractor under his contract; or where sufficient contract funds are unavailable for this purpose, the Contractor or his surety shall reimburse the Town of Addison for all such costs.

76. **CONSTRUCTION TRAFFIC OVER PIPE LINES:** The design of the new pipes and the design of the existing pipe have been taken into account and provided for highway live loads. It is apparent, however, that certain construction vehicles could exceed this highway load condition under shallow bury conditions. It will be the responsibility of the Contractor to protect both the new line and the existing lines from these possibly excessive loads. The Contractor shall not at any time cross the existing or new pipe with a construction vehicle. Any damage to the existing or new pipe will be repaired or replaced by the Contractor to the satisfaction of the Town of Addison.

In locations where it is not permissible to cross the existing or proposed pipes without additional protection, the Contractor may elect to provide additional protection of the pipes so that more frequent crossings of the pipes are allowed. It still is, however, the responsibility of the Contractor to repair any damage to the existing or proposed lines if the damage results from any phase of his construction operation.

77. **CONTRACTOR'S CONTINUING OBLIGATION:** Contractor's obligation to perform and complete the Work in accordance with the Contract Documents shall be absolute. Neither recommendation of any progress or final payment by the Town of Addison, nor the issuance of a certificate of Substantial Completion, nor any payment by Town of Addison to Contractor under the Contract Documents, nor any use or occupancy of the Work or any part thereof by Town of Addison, nor any act of acceptance by Town of Addison nor any failure to do so, nor any review and approval of a Shop Drawing or sample submission, nor the issuance of a notice of acceptability by the Town of Addison pursuant to final payment nor any correction of defective Work by Town of Addison will constitute an acceptance of Work

not in accordance with the Contract Documents or a release of Contractor's obligation to perform the Work in accordance with the Contract Documents.

78. **TOP SOILING, SEEDING AND FERTILIZING:** This item shall cover the topsoiling, seeding, fertilizing, watering and required maintenance for the grassing of all unpaved areas of the right-of-way and the easements, and all other areas of the project site that have been disturbed by this Contractors' operations including batch plant site, haul roads, etc. excluding building pad sites and lots which will not require seeding and fertilizing. The pay item shall only include that area which is within the right-of-way and the easements. All other disturbed areas requiring seeding and fertilizing shall be considered subsidiary to the cost of the project. Top soiling, seeding and fertilizing shall be provided in accordance with NCTCOG Items 202.2, 202.4 and 202.6, respectively and as amended by the Special Provisions and Technical Specifications.

79. **IRRIGATION AND SPRINKLER REPAIR:** The Contractor shall maintain all existing irrigation systems within the limits of the project during the duration of the contract. The Contractor shall employ a licensed irrigator who is responsible for the repair or replacement of any damage to irrigation lines, valves, controllers, sprinklers, wiring and appurtenances which are damaged during construction. This repair is subsidiary to the various other items bid. The Contractor will be responsible for any vegetation that dies as a result of damage to the irrigation system and replace it with equal vegetation at his own cost.

After construction is complete, the Contractor shall reinstall the sprinkler heads. The Town will test the sprinkler system. Any defects due to construction shall be the Contractor's responsibility.

80. **REMOVAL OF DEFECTIVE AND UNAUTHORIZED WORK:** All work which has been rejected or condemned shall be repaired; or if it cannot be repaired satisfactorily, it shall be removed and replaced at the Contractor's expense. Defective materials shall be immediately removed from the work site. Work done without line and grade having been provided; work done beyond the line or not in conformity with the grades shown on the Drawings or as provided, work done without proper inspection; or any extra or unclassified work done without written authority and prior agreement in writing as to prices, shall be at the Contractor's risk and will be considered unauthorized, and at the option of the Town of Addison may not be measured and paid for and may be ordered removed at the Contractor's expense. Upon failure of the Contractor to repair satisfactorily or to remove and replace, if so directed, rejected, unauthorized or condemned work or materials immediately after receiving notice from the Town of Addison, the Town will, after giving written notice to the Contractor, have the authority to cause defective work to be remedied or removed and replaced, or to cause unauthorized work to be removed and to deduct the cost thereof from any monies due or to become due the Contractor.

81. **DISPOSITION AND DISPOSAL OF MATERIALS:** All materials to be removed from the site including refuse and other debris shall become the property of the Contractor and shall be disposed of outside the limits of the project. Contractor shall also comply with all

applicable laws governing the spillage of debris while transporting to a disposal site. Refer to Technical Specification 017420, "Sediment Disposal", for details.

82. **CLEAN-UP FOR FINAL ACCEPTANCE:** The Contractor shall make a final cleanup of all parts of the work before acceptance by the Town of Addison. This cleanup shall include removal of all objectionable rock and other construction materials, and in general preparing the site of the work in an orderly manner and appearance.
83. **TV INSPECTION OF SANITARY SEWER AND STORM DRAIN SYSTEMS:** No TV inspection of sanitary sewer and storm drain systems is required for this project.
84. **MATERIALS TO BE FURNISHED BY FRANCHISE UTILITY COMPANIES:** No franchise utility materials are to be furnished for this project.
85. **TESTING REQUIREMENTS:** Testing shall be conducted in accordance with Town of Addison Specifications except as modified in the Special Provisions, Technical Specifications, or as on the plans. The Town of Addison will provide random testing. The Contractor shall coordinate construction with the Town of Addison, and shall provide assistance to the testing labs by providing trench safety, excavation, or other work to insure all testing requirements are met. Work performed to accommodate testing will be a subsidiary item and no extra payment will be authorized. All retesting shall be at the expense of the Contractor. As a general guide, the Contractor shall be responsible for providing the following tests:
- (1) Density and associated tests on embedment and backfill.
 - (2) Compressive strength tests on concrete.
 - (3) Gradation soil tests on backfill as may be required.
 - (4) Providing test results from manufacturer as specified in Town of Addison Specifications.
 - (5) Chemical and metal content and water ratio of dewatered silt.
86. **SILICONE JOINT SEALANT:** Silicone joint sealant must be used in all instances where joint sealant applies to Portland Cement Concrete pavement and curbs. Payment for the use of silicone joint throughout this project will in all cases be subsidiary to this contract at no extra cost.
87. **CLAIMS FOR DAMAGES OR INJURY:** Item 1.24.3 - SMALL CLAIMS FOR DAMAGE OR INJURY is amended to read as follows: If any person files a claim against the Town of Addison or Contractor for personal injury or property damage resulting from, arising out of, or caused by, the operations of the Contractor, or any work within the limits of the project, the Contractor must either submit to the Town of Addison, a duly executed full release within thirty (30) days from the date of written claim, or immediately report the claim to his liability insurance carrier for their action in adjusting the claim. If the Contractor fails to comply with this provision within the stipulated time limit, it will be automatically deemed that the Contractor has appointed the Town as its irrevocably Attorney-In-Fact authorizing the Town to report the claim directly with the liability insurance carrier. This provision is in and of itself a Power-of-Attorney from the Contractor to the Town which

authorizes the Town to take said action on behalf of the Contractor without the necessity of the execution of any other document. If the Contractor fails to comply with the provisions of this item the Town, at its own discretion, may terminate this contract or take any other actions it deems appropriate. Any payment or portion thereof due the Contractor, whether it is a final payment, progress payment, payment out of retainage or refund payment may be withheld by the Town as is authorized by Item 109.4. Bankruptcy, insolvency or denial of liability by the insurance carrier shall not exonerate the Contractor from liability.

As a result of the additional work created to Town of Addison due to un-responded claims for damages by Contractor to third parties, Contractor shall incur penalties for failure to abide by this Special Provision.

Contractor shall respond to the claimant in writing regarding the status of the claim, including whether Contractor disputes the claim, wishes to settle, or will notify its liability insurance carrier regarding the claim. Contractor will be assessed a penalty by the Town of \$75.00 per claim, for its failure to respond to the claimant as described above within thirty days of its written notice of claim by the Town.

To ensure Contractor compliance, the Town of Addison shall be notified, by copied correspondence of responses or settlement by Contractor.

- 88. WAIVER OF CLAIMS:** The making and acceptance of final payment will constitute:
- A. A waiver of all claims by Town of Addison against Contractor, except claims arising from unsettled Liens, from defective Work appearing after final inspection or failure to comply with the Contract Documents or the terms of any special guarantees specified therein; however, it will not constitute a waiver by Town of Addison of any rights in respect of Contractor's continuing obligations under the Contract Documents.
 - B. A waiver of all claims by Contractor against Town of Addison other than those previously made in writing and still unsettled.
- 89. MECHANICS AND MATERIALMEN'S LIEN:** The Contractor shall be required to execute a release of mechanics and materialmen's liens upon receipt of payment.
- 90. CONTRACTOR'S AFFIDAVIT OF BILLS PAID:** The Contractor shall be required to execute the form provided in Section BP prior to the acceptance of the project.
- 91. PRODUCT RECORD DOCUMENTS:** The Contractor shall maintain record drawings and legibly annotate shop drawings to record changes made after review. A red felt-tip marking pen shall be used for all recording.

Maintenance of Documents: The Contractor shall maintain at the job site one record copy of the Contract Drawings, Specifications, Shop Drawings, Change Orders, other modification to the Contract, field test records and other documents submitted by Contractor in compliance with specification requirements. These documents shall be maintained at the job site apart

from documents used for construction. These documents are not to be used for construction purposes. The documents shall be maintained in clean, legible condition. The documents shall be made available at all times for inspection by the Town.

Recording: Each document shall be labeled Project Record Copy in 2-inch high printed letters. The record documents shall be kept current. No work shall be covered until required information has been recorded.

Contract Drawings: The appropriate drawing shall be legibly marked to record, where applicable:

- a. Horizontal and vertical location of underground utilities and appurtenances referenced to permanent surface improvements.
- b. Field changes of dimension and detail made during construction process.
- c. Changes made by Change Order or Supplemental Agreement.
- d. Details not on original Contract Drawings.
- e. Manufacturer, trade name, catalog number and supplier of each product and item of equipment actually installed.
- f. Changes made by Change Order or Supplemental Agreement.
- g. Other matters not originally specified.

Shop Drawing: The Contractor shall maintain the Shop Drawings as record drawings and legibly annotate shop drawings to record changes made after review.

Submittal: At the completion of the project, the Contractor shall deliver record drawings to the Town. The transmittal letter shall be accompanied, in duplicate, with:

- a. Date, project title and number.
- b. Contractor's name and address.
- c. Title and number of each record document.
- d. Certification that each document as submitted is complete and accurate.
- e. Signature of Contractor or his authorized representative.

92. TOWN OF ADDISON APPROVAL: This project is subject to final approval and acceptance by the Town of Addison. Final approval acceptance will not be given until the punch list items are completed to the Town's satisfaction and as-built drawings are given to the Town of Addison.

93. USE OF EXPLOSIVES: The use of explosives by the Contractor to complete the Work shall be prohibited.

94. **POWER FOR CONSTRUCTION:** The Contractor shall contract with the local power provider and make the necessary arrangements for securing power required for the construction, including power required for lighting, machinery operation, or temporary offices. There will be no separated pay item for connection into the existing power system or for the power required for construction purposes.
95. **LIQUIDATED DAMAGES:** If the Contractor fails to complete the work within the time specified in the contract, the Contractor shall pay liquidated damages to the Town of Addison in the amount of \$ 1,000 for each calendar day of delay until the work is completed or accepted.
96. **PREVAILING WAGE RATES:** Wage rates paid on this project shall not be less than specified in the schedule of general prevailing rates of per diem wages as attached hereto under Davis & Bacon Wage Determinations for Heavy Highway.

PREVAILING WAGE RATES

General Decision Number: TX160028 01/08/2016 TX28

Superseded General Decision Number: TX20150028

State: Texas

Construction Type: Heavy

Counties: Collin, Dallas, Denton, Ellis, Kaufman and Rockwall

Counties in Texas.

Water and Sewer Lines/Utilities (Including Related Tunneling

where the Tunnel is 48" or Less in Diameter)

Note: Under Executive Order (EO) 13658, an hourly minimum wage of \$10.15 for calendar year 2016 applies to all contracts subject to the Davis-Bacon Act for which the solicitation was issued on or after January 1, 2015. If this contract is covered by the EO, the contractor must pay all workers in any classification listed on this wage determination at least \$10.15 (or the applicable wage rate listed on this wage determination, if it is higher) for all hours spent performing on the contract in calendar year 2016. The EO minimum wage rate will be adjusted annually. Additional information on contractor requirements and worker protections under the EO is available at www.dol.gov/whd/govcontracts.

Modification Number Publication Date

0 01/08/2016

* PLUM0100-002 07/01/2013

	Rates	Fringes
Plumbers and Pipefitters.....	\$ 28.88	8.83

SUTX1991-004 09/23/1991

	Rates	Fringes
Laborers:		
Common.....	\$ 7.25	
Utility.....	\$ 7.467	
Pipelayer.....	\$ 7.828	
Power equipment operators:		
Backhoe.....	\$ 10.804	
Crane.....	\$ 10.942	
Front End Loader.....	\$ 9.163	
Tunneling Machine (48" or less).....	\$ 9.163	
TRUCK DRIVER.....	\$ 8.528	

WELDERS - Receive rate prescribed for craft performing operation to which welding is incidental.

=====

Unlisted classifications needed for work not included within the scope of the classifications listed may be added after award only as provided in the labor standards contract clauses (29CFR 5.5 (a) (1) (ii)).

The body of each wage determination lists the classification and wage rates that have been found to be prevailing for the cited type(s) of construction in the area covered by the wage determination. The classifications are listed in alphabetical order of "identifiers" that indicate whether the particular rate is a union rate (current union negotiated rate for local), a survey rate (weighted average rate) or a union average rate (weighted union average rate).

Union Rate Identifiers

A four letter classification abbreviation identifier enclosed in dotted lines beginning with characters other than "SU" or "UAVG" denotes that the union classification and rate were prevailing for that classification in the survey. Example: PLUM0198-005 07/01/2014. PLUM is an abbreviation identifier of the union which prevailed in the survey for this classification, which in this example would be Plumbers. 0198 indicates the local union number or district council number where applicable, i.e., Plumbers Local 0198. The next number, 005 in the example, is an internal number used in processing the wage determination. 07/01/2014 is the effective date of the most current negotiated rate, which in this example is July 1, 2014.

Union prevailing wage rates are updated to reflect all rate changes in the collective bargaining agreement (CBA) governing this classification and rate.

Survey Rate Identifiers

Classifications listed under the "SU" identifier indicate that no one rate prevailed for this classification in the survey and the published rate is derived by computing a weighted average rate based on all the rates reported in the survey for that classification. As this weighted average rate includes all rates reported in the survey, it may include both union and non-union rates. Example: SULA2012-007 5/13/2014. SU indicates the rates are survey rates based on a weighted average calculation of rates and are not majority rates. LA indicates the State of Louisiana. 2012 is the year of survey on which these classifications and rates are based. The next number, 007 in the example, is an internal number used in producing the wage determination. 5/13/2014 indicates the survey completion date for the classifications and rates under that identifier.

Survey wage rates are not updated and remain in effect until a new survey is conducted.

Union Average Rate Identifiers

Classification(s) listed under the UAVG identifier indicate that no single majority rate prevailed for those classifications; however, 100% of the data reported for the classifications was union data. EXAMPLE: UAVG-OH-0010 08/29/2014. UAVG indicates that the rate is a weighted union average rate. OH indicates the state. The next number, 0010 in the example, is an internal number used in producing the wage determination. 08/29/2014 indicates the survey completion date for the classifications and rates under that identifier.

A UAVG rate will be updated once a year, usually in January of each year, to reflect a weighted average of the current negotiated/CBA rate of the union locals from which the rate is based.

WAGE DETERMINATION APPEALS PROCESS

1.) Has there been an initial decision in the matter? This can be:

- * an existing published wage determination
- * a survey underlying a wage determination
- * a Wage and Hour Division letter setting forth a position on a wage determination matter
- * a conformance (additional classification and rate) ruling

On survey related matters, initial contact, including requests for summaries of surveys, should be with the wage and Hour Regional Office for the area in which the survey was conducted because those Regional Offices have responsibility for the Davis-Bacon survey program. If the response from this initial contact is not satisfactory, then the process described in 2.) and 3.) should be followed.

with regard to any other matter not yet ripe for the formal process described here, initial contact should be with the Branch of Construction Wage Determinations. Write to:

Branch of Construction Wage Determinations
Wage and Hour Division
U.S. Department of Labor
200 Constitution Avenue, N.W.
Washington, DC 20210

2.) If the answer to the question in 1.) is yes, then an interested party (those affected by the action) can request review and reconsideration from the Wage and Hour Administrator. (See 29 CFR Part 1.8 and 29 CFR Part 7). Write to:

Wage and Hour Administrator
U.S. Department of Labor
200 Constitution Avenue, N.W.
Washington, DC 20210

The request should be accompanied by a full statement of the interested party's position and by any information (wage payment data, project description, area practice material, etc.) that the requestor considers relevant to the issue.

3.) If the decision of the Administrator is not favorable, an interested party may appeal directly to the Administrative Review Board (formerly the Wage Appeals Board). Write to:

Administrative Review Board
U.S. Department of Labor
200 Constitution Avenue, N.W.
Washington, DC 20210

4.) All decisions by the Administrative Review Board are final.

=====

END OF GENERAL DECISION

97. **BID ITEMS/REFERENCE SPECIFICATIONS:** The requirements of NCTCOG standard specifications for Public Works construction 4th Edition dated 2004, and TxDOT standard specifications for construction and maintenance of highways, streets and bridges, dated 2004, shall apply as described.

98. **BID ITEM DESCRIPTIONS**

The series of numbers shown after the description are for either the Texas Department of Transportation (TxDOT) Standard Specifications for Construction and Maintenance of Highways, Streets, and Bridges (2004), the North Central Texas Council of Governments (NCTCOG) Standard Specifications for Public Works Construction, Fourth Edition (October 2004), or technical specifications number provided with this document.

SITE PREPARATION AND MISCELLANEOUS

BID ITEM NO. 001 – Mobilization (no more than 5% of total bid)

The provisions of TxDOT Item 500, “Mobilization”, shall apply except as modified or clarified below:

- A. Partial payments of the lump sum bid for mobilization shall be per the provisions of TxDOT Item 500.
- B. Measurement for this bid item shall be for Lump Sum.
- C. Payment for this bid item shall be paid for at the unit price bid for “Mobilization”.

BID ITEM NO. 002 – Traffic Control

The following provisions shall apply:

- A. Contractor shall submit proposed traffic control plan (TCP) to the Engineer and Town for approval. The TCP must conform to guidelines established in the Texas Manual of Uniform Traffic Control Devices (TMUTCD).
- B. This item includes all labor, equipment, materials and incidentals required to provide traffic control as necessary. Materials include but are not limited to signage including full time changeable message signs, traffic control devices, barricades, low profile concrete barrier, temporary striping, and any other items called for in the plans or necessary for the safe and efficient operation of traffic.
- C. Contractor shall provide access to existing driveways at all times, except when concrete is curing. Gravel shall be placed at driveways and sidewalks once existing pavement has been removed for construction. Gravel material is incidental to this bid item.
- D. Street access shall be maintained at all times for emergency vehicles.

- E. Measurement for this bid item shall be per Lump Sum.
- F. Payment for this bid item shall be paid for at the unit price bid for “Traffic Control”.

BID ITEM NO. 003 – SW3P Including Maintenance, Inlet Protection, Erosion Control, and Construction Exit

The provisions of NCTCOG Item 201, “Temporary Erosion, Sedimentation, and Water Pollution Prevention and Control”, shall apply except as modified or clarified below:

- A. This item includes all labor, equipment, materials, planning, excavating, compacting, testing and incidentals required to complete the work in accordance with plans and specifications.
- B. Refer to NCTCOG Item 201.3, “Preconstruction Submittals”, and Special Provisions, Number 15, “Preparations of Storm Water Pollution Prevention Plan,” for additional specification on submitting the Storm Water Pollution Prevention Plan prior to the beginning of construction.
- C. Refer to NCTCOG Item 201.4, “Construction Requirements”, for additional specification on erosion control during construction.
- D. Refer to NCTCOG Item 201.5, “Silt Fence”, for additional specification regarding inlet protection.
- E. Refer to NCTCOG Item 201.14, “Inlet Protection”, for additional specification regarding inlet protection.
- F. Contractor shall refer to the Stormwater Pollution Prevention Plan (SWPPP) for requirements of all temporary and permanent erosion control measures. Preparation of the SWPPP shall be subsidiary to these bid items.
- G. Refer to Erosion Control Details and Notes.
- H. Measurement for this bid item shall be per Lump Sum, including silt fence, inlet protection, construction exit, and SW3P maintenance and erosion control.
- I. Payment for this bid item shall be paid for at the unit price bid for “SW3P Including Maintenance, Inlet Protection, Erosion Control, and Construction Exit”.

BID ITEM NO. 004 – Trench Safety System

The provisions of TxDOT Item 402, “Trench Excavation Protection”, shall apply except as modified or clarified below:

- A. In addition to personnel safety, the “Trench Safety Plan”, developed by the Contractor, must provide for sheeting and shoring procedures capable of providing support of the trenches, giving due consideration to the proximity of existing structures and other facilities.
- B. Measurement for this bid item shall be per Lump Sum.
- C. Payment for this bid item shall be paid for at the unit price bid for “Safety System”.

BID ITEM NO. 005 – Project Signs

The provisions of NCTCOG Item 107.20, “Project Signs”, shall apply except as modified or clarified below:

- A. The Contractor shall be responsible for furnishing the project signs per the specifications shown on the Project Sign Detail Sheet (see Section PS of this Contract Documents and Specifications book).
- B. Measurement for this bid item shall be for Each.
- C. Payment for this bid item shall be paid for at the unit price bid for “Project Signs”.

BID ITEM NO. 006 –Remove Existing Concrete Sidewalk

The provisions of TxDOT Item 104, “Removing Concrete”, shall apply except as modified or clarified below:

- A. This item includes all labor, equipment, materials and incidentals required to eliminate existing concrete in accordance with plans and specifications.
- B. All concrete to be removed shall be sawcut. Sawcut shall be subsidiary to removal bid items.
- C. This item when called for in the plans shall include saw cutting the concrete and disposal of the material at an approved location outside of the project limits. This surplus material shall become property of the Contractor.
- D. Concrete shall be properly disposed of at an off-site location by the Contractor.
- E. Measurement for this bid item shall be per Square Foot.
- F. Payment for this bid item shall be paid for at the unit price bid for “Remove Existing Concrete Sidewalk.”

BID ITEM NO. 007 – Remove Existing Concrete Box Fountain (including Lights, Piping and Electrical Wires)

The following provisions shall apply:

- A. Refer to Technical Specification Section 01732, “Demolition” for additional requirements.
- B. Refer to Demolition Plan for location, details, and general notes.
- C. This item includes all labor, equipment, materials, excavating, compacting, testing and incidentals required to complete the work in accordance with plans and specifications.
- D. Measurement for this bid item shall be per Each (concrete box fountain), which includes the piping, lights, and electrical wires.
- E. Payment for this bid item shall be paid for at the unit price bid for “Remove Existing Concrete Box Fountain (including Lights, Piping and Electrical Wires)”.

BID ITEM NO. 008 – Remove Submersible Fountain Pump

The following provisions shall apply:

- A. Refer to Technical Specification Section 01732, “Demolition” for additional requirements.
- B. Refer to Demolition Plan for location, details, and general notes.
- C. This item includes all labor, equipment, materials, excavating, compacting, mechanical and electrical removal, and incidentals required to complete the work in accordance with plans and specifications.
- D. Measurement for this bid item shall be per Each.
- E. Payment for this bid item shall be paid for at the unit price bid for “Remove Submersible Fountain Pump”.

BID ITEM NO. 009 – Aquatic Species Recovery and Relocation Coordination

The following provisions shall apply:

- A. Refer to Technical Specification Section 02243, “Aquatic Species Recovery and Relocation” for additional requirements.
- B. This item includes but is not limited to attending preconstruction and scheduling meetings with the Aquatic Species Recovery and Relocation Specialists (Half) and the Town of Addison, unwatering the ponds per coordination with the Specialists and the Aquatic Resource Relocation Plan (ARRP), notifying the Specialists and the Town of any schedule-related events and wildlife sightings, and providing boat access assistance.
- C. The Contractor shall supply the equipment necessary to lift the Specialists’ boat in and out of the ponds. All other equipment pertaining to aquatic species recovery and relocation shall be provided by the Specialists.
- D. The Specialists shall have a separate contract with the Town of Addison. The Specialists’ work shall not be included in this bid proposal.
- E. Measurement for this bid item shall be per Lump Sum.
- F. Payment for this bid item shall be paid for at the unit price bid for “Aquatic Species Recovery and Relocation Coordination”.

BID ITEM NO. 010 – Bypass Pumping

The following provisions shall apply:

- A. Refer to Technical Specification Section 02241, “Bypass Pumping” for additional requirements.

- B. Refer to Plans, Suggested Sequencing, and Traffic Control Plan for additional information on location, details, and general notes.
- C. This item includes all supervision, labor, equipment, maintenance, monitoring, tools materials, excavating, compacting, and incidentals required to complete the work in accordance with plans and specifications.
- D. Measurement for this bid item shall be per Month.
- E. Payment for this bid item shall be paid for at the unit price bid for “Bypass Pumping”.

BID ITEM NO. 011 – Unwatering of Ponds

The following provisions shall apply:

- A. Refer to Technical Demolition Specification Section 01732, “Demolition” for additional requirements.
- B. Refer to Demolition Plan for location, details, and general notes.
- C. This item includes all labor, equipment, materials, excavating, pumping, piping, filtering, compacting, and incidentals required to complete the work in accordance with plans and specifications.
- D. Measurement for this bid item shall be per Lump Sum.
- E. Payment for this bid item shall be paid for at the unit price bid for “Unwatering of Ponds”.

BID ITEM NO. 012 – Desilting (including Excavation, Dewatering and Disposal of Contaminated Water)

The following provisions shall apply:

- A. Refer to Technical Specification Sections 02240, “Unwatering”; 02241, “Bypass Pumping”; 02242, “Dewatering”; and 02300, “Earthwork for Pavements, Trails and Slope Protection”, for additional requirements.
- B. Refer to Plans for location, details, and general notes.
- C. This item includes all labor, equipment, materials, excavating, compacting, dewatering, brush removal, disposal of contaminated water, protection for structures to remain, and incidentals required to complete the work in accordance with plans and specifications.
- D. Measurement for this bid item shall be per Cubic Yard of excavated silt. Estimated quantity to be removed is not guaranteed and the Contractor will be paid at the contractual unit rate whether the amount of dredging is larger or smaller than the estimate.
- E. Payment for this bid item shall be paid for at the unit price bid for “Desilting (including Excavation, Dewatering and Disposal of Contaminated Water”.

BID ITEM NO. 013 – Sediment Disposal (including testing, permitting, transportation, and disposal)

The following provisions shall apply:

- A. Refer to Technical Specification Sections 01732, “Demolition”; 02242, “Dewatering”; and 017420, “Sediment Disposal”, for additional requirements.
- B. Refer to Plans for location, details, and general notes.
- C. This item includes all labor, equipment, testing, permitting, compacting, transportation, disposal fees, and incidentals required to complete the work in accordance with plans and specifications.
- D. Silt disposal shall be outside of the Owner’s property and city limits.
- E. Measurement for this bid item shall be per Cubic Yard of disposed sediment. Estimated quantity to be removed is not guaranteed and the Contractor will be paid at the contractual unit rate whether the amount of dredging is larger or smaller than the estimate.
- F. Payment for this bid item shall be paid for at the unit price bid for “Sediment Disposal (including testing, permitting, transportation, and disposal”.

PAVING AND SIDEWALKS

BID ITEM NO. 101 – Concrete Sidewalk

The provisions of NCTCOG Item 305.2, “Sidewalks”, shall apply except as modified or clarified below:

- A. This item includes all labor, equipment, materials, grading and incidentals required to provide a finished concrete pavement section including any required saw joints and expansion joints in accordance with the specifications. Any concrete sidewalk which tests below the required strength or is out of alignment or is of insufficient thickness, is subject to removal and replacement at the Engineer’s sole discretion at the Contractor’s expense.
- B. Sidewalks shall have a thickness of five inches (5”).
- C. Concrete shall be Class ‘C’ concrete designed to meet an average compressive strength of 3,600 psi at 28 days.
- D. Measurement for this bid item shall be per Square Foot.
- E. Payment for this bid item shall be paid for at the unit price bid for “Concrete Sidewalk”.

BID ITEM NO. 102 – Temporary Asphalt Sidewalk

The provisions of NCTCOG Item 302, “Asphalt Pavement”, shall apply except as modified or clarified below:

- F. This item includes all labor, equipment, materials, grading and incidentals required to provide a finished concrete pavement section including any required saw joints and expansion joints in accordance with the specifications. Any concrete sidewalk which tests below the required strength or is out of alignment or is of insufficient thickness, is subject to removal and replacement at the Engineer's sole discretion at the Contractor's expense.
- G. Sidewalks shall have a thickness of four inches (4").
- H. Asphalt shall be HMAC Type 'D'.
- I. Measurement for this bid item shall be per Square Yard. Payment for this bid item shall be paid for at the unit price bid for "Temporary Asphalt Sidewalk".

BID ITEM NO. 103 – Flowable Fill Concrete

The provisions of NCTCOG Item 504.2.3.4, "Flowable Backfill", shall apply except as modified or clarified below:

- A. This item includes all labor, equipment, materials and incidentals required to provide a finished concrete section. Any concrete which tests below the required strength, is subject to removal and replacement at the Engineer's sole discretion at the Contractor's expense.
- B. Flowable fill concrete shall be designed to meet an average compressive strength of 250 psi to 450 psi at 28 days.
- C. Flowable fill concrete shall be used to fill the pipe trenches in the pond bottom and the submersible fountain shafts. Refer to Plans for location and general notes.
- D. Measurement for this bid item shall be per Cubic Yard.
- E. Payment for this bid item shall be paid for at the unit price bid for "Flowable Fill Concrete".

LANDSCAPE IMPROVEMENTS

BID ITEM NO. 201 – Soil Prep Material and Landscape Grading

The following provisions shall apply:

- A. Refer to Technical Specification Section 32 91 19, "Landscape Grading" for additional requirements.
- B. Refer to Plans for location, details, and general notes.
- C. This item includes all labor, equipment, materials, excavating, compacting, and incidentals required to complete the work in accordance with plans and specifications.
- D. Measurement for this bid item shall be Square Foot.
- E. Payment for this bid item shall be paid for at the unit price bid for "Soil Prep Material and Landscape Grading".

BID ITEM NO. 202 – Turf Reinforcement Mat

The following provisions shall apply:

- A. Refer to Technical Specification Section 01568, “Erosion Control” for additional requirements.
- B. Turf Reinforcement Mats shall be North American Green V Max P550 or equivalent.
- C. Turf Reinforcement Mats shall be installed in accordance with the plan details and manufacturer’s instructions.
- D. This item includes all labor, equipment, materials, excavating, compacting, and incidentals required to complete the work in accordance with plans and specifications.
- E. Measurement for this bid item shall be Square Yard installed.
- F. Payment for this bid item shall be paid for at the unit price bid for “Turf Reinforcement Mat” for the location specified.

BID ITEM NO. 203 – Common Bermuda 'Mid Iron' Sod

The following provisions shall apply:

- D. Refer to Technical Landscape Specification Section 32 92 23, “Sodding” for additional requirements.
- E. Refer to Plans for location and general notes.
- F. This item includes all labor, equipment, materials, excavating, compacting, and incidentals required to complete the work in accordance with plans and specifications.
- G. Measurement for this bid item shall be per Square Foot.
- H. Payment for this bid item shall be paid for at the unit price bid for "Common Bermuda Mid Iron Sod".

BID ITEM NO. 204 – Wood Chips

The following provisions shall apply:

- A. Refer to Plans for location and general notes.
- B. This item includes all labor, equipment, materials, excavating, compacting, and incidentals required to complete the work in accordance with plans and specifications.
- C. Measurement for this bid item shall be per Square Foot.
- D. Payment for this bid item shall be paid for at the unit price bid for "Wood Chips".

BID ITEM NO. 205 – Tree Trimming

The following provisions shall apply:

- A. Refer to Technical Specification Section 32 93 00, “Landscape Planting” for additional requirements.
- B. Tree trimming shall occur within the project limits. Refer to Plans for location, details, and general notes.
- C. This item includes all labor, equipment, materials, disposal, and incidentals required to complete the work in accordance with plans and specifications.
- D. Measurement for this bid item shall be Lump Sum.
- E. Payment for this bid item shall be paid for at the unit price bid for “Tree Trimming”.

BID ITEM NO. 206 – Tree Removal and Grubbing

The provisions of TxDOT Item 752, “Tree and Brush Removal”, and NCTCOG Item 202.1, “Removal, Protection, and Replacement of Trees, Shrubbery, Plants, Sod, and Other Vegetation”, shall apply except as modified or clarified below:

- A. Refer to Removal Plans for locations, general notes, and details of trees to be removed.
- B. No trees are to be replaced.
- C. Measurement for this bid item shall be per Each.
- D. Payment for this bid item shall be paid for at the unit price bid for “Tree Removal and Grubbing”.

BID ITEM NO. 207 – Tree Protection

The provisions of NCTCOG Item 202.1, “Removal, Protection, and Replacement of Trees, Shrubbery, Plants, Sod, and Other Vegetation” shall apply except as modified or clarified below:

- A. All trees not noted in Demolition plans as to be removed shall be protected.
- B. This item includes all labor, equipment, materials, excavating, compacting, and incidentals required to complete the work in accordance with plans and specifications.
- C. Measurement for this bid item shall be per Lump Sum.
- D. Payment for this bid item shall be paid for at the unit price bid for “Tree Protection”.

BID ITEM NO. 208 – 90 Day Establishment Period

The following provisions shall apply:

- A. Refer to Technical Specification Section 32 01 90, “90 Day Establishment Planting” for additional requirements.
- B. Refer to Construction Plans for details, and general notes.
- C. This item includes all labor, equipment, materials, and incidentals required to implement landscape maintenance program for a period of 90days after planting in accordance with plans and specifications.
- D. Measurement for this bid item shall be Lump Sum.
- E. Payment for this bid item shall be paid for at the unit price bid for “90 Day Establishment Period”.

BID ITEM NO. 209 – 1 Year Maintenance

The following provisions shall apply:

- A. Refer to Technical Specification Section 32 01 92, “Landscape Maintenance - 1 Year” for additional requirements.
- B. Refer to Construction Plans for details, and general notes.
- C. This item includes all labor, equipment, materials, and incidentals required to implement landscape maintenance program for a period of 1 year after final acceptance from Town in accordance with plans and specifications.
- D. Measurement for this bid item shall be Lump Sum.
- E. Payment for this bid item shall be paid for at the unit price bid for Implementation of Landscape Maintenance Program for a Period of (1) Year from Date of Final Acceptance.

SECTION PS

PROJECT SIGN

PROJECT SIGN

1. Quantity

Three (3) Project Designation signs will be constructed and installed on the project site as directed by the Owner. It will be the responsibility of the Contractor to maintain the sign in a presentable condition at all times during construction. Maintenance will include painting and repairs as directed by the City Engineer or his appointee. The locations of the signs will be given to the Contractor by the Town of Addison at the Pre-Construction Conference.

2. Material

Sign shall be constructed of ¾-inch thick smooth finish fir plywood (Grade A-C, exterior or better).

Sign will be securely mounted to 6" x 6" square posts. Nuts and bolts will not protrude from face of sign. Posts will be mounted to a support system that will provide adequate stabilization to ensure the sign will not fall over in heavy winds. Sand bags or other techniques may be necessary to protect sign.

3. Dimensions

Size of sign will be four feet tall and six feet wide. The height and arrangement of the lettering shall be in accordance with the attached detail.

4. Paint

Sign will be one-sided and will have a white background. Text will be black, except for the word "Addison!" which will be a blue color approved by the City Engineer. The paint will be an outdoor paint and will be maintained throughout the project in proper order. The quality of the paint, painting, and lettering on the signs shall be approved by the City Engineer or his appointee.

5. Payment

Project Signs will be a separate pay item. This will include all labor, equipment, tools, and incidentals necessary to complete and install the work.

The Town of



**PLEASE PARDON THE TEMPORARY
INCONVENIENCE DURING THIS PROJECT**

WINNWOOD POND DREDGING

CONTRACTOR: _____

ESTIMATED COMPLETION DATE: XXXX

AN ADDISON PROJECT

FOR MORE INFORMATION, PLEASE CALL (972) 450-2871

SECTION TS

TECHNICAL SPECIFICATIONS

01010	SUMMARY OF WORK
01330	SUBMITTAL PROCEDURES
01395	TRENCH SAFETY
01400	QUALITY CONTROL
01568	EROSION CONTROL
01710	SITE CLEARING AND ADJUSTING
01732	DEMOLITION
01742	SEDIMENT DISPOSAL
02212	EMBANKMENT AND EARTHWORK FOR STRUCTURES
02231	TREE PROTECTION
02240	UNWATERING
02241	BYPASS PUMPING
02242	DEWATERING
02243	AQUATIC SPECIES RECOVERY AND RELOCATION
02300	EARTHWORK FOR PAVEMENTS, TRAILS AND SLOPE PROTECTION
32 01 90	90 DAY ESTABLISHMENT PLANTING
32 01 92	LANDSCAPE MAINTENANCE – 1 YEAR
32 91 19	LANDSCAPE GRADING
32 92 23	SODDING
32 93 00	LANDSCAPE PLANTING

SECTION 01010

SUMMARY OF WORK

PART 1 - GENERAL

1.1 RELATED DOCUMENTS

- A. Drawings and general provisions of the Contract, including General and Supplementary Conditions and other Specification Sections apply to this Section.

1.2 SUMMARY

- A. This Section includes the following:
 - 1. Definitions for terms used in specifications and plans
 - 2. Work covered by the Contract Documents.
 - 3. Work phases.
 - 4. Use of premises.
 - 5. Work restrictions.

1.3 DEFINITIONS FOR TERMS USED IN SPECIFICATIONS AND PLANS

- A. Bypass: a secondary channel, pipe, or connection to carry a fluid around part and back to the main stream.
- B. Dewater: to remove water from silt, wastes, soils or chemicals (TCEQ).
- C. Evaporation pond: a contaminant area where liquids are allowed to evaporate. In some cases, a spraying mechanism is used to speed evaporation (TCEQ).
- D. Groundwater: the supply of fresh water found beneath the earth's surface (usually in aquifers) that is often used for supplying wells and springs (TCEQ).
- E. Heavy Metals: metallic elements with high atomic weights, e.g., mercury, chromium, cadmium, arsenic, or lead (TCEQ).
- F. Impoundment: a body of water or sludge confined by a dam, dike, floodgate or other barrier (TCEQ).
- G. Non-turbid: a discharge that does not cause or contribute to an exceedance of turbidity-related water quality standards (EPA).
- H. Pollutant: Dredged spoil, solid waste, incinerator residue, sewage, garbage, sewage sludge, filter backwash, muntions, chemical wastes, biological materials, radioactive materials, heat, wrecked or discarded equipment, rock, sand, cellar dirt, and industrial, municipal, and agricultural waste discharged into any surface water in the state. The term "pollutant" does not include tail water or runoff water from irrigation or rainwater runoff from cultivated or uncultivated rangeland, pastureland, and farmland (EPA). For the purpose of the TPDES General Permit TXR150000, the term "pollutant" includes sediment (TCEQ).

- I. Sediment: the layer of soil, sand and minerals at the bottom of surface water that absorbs contaminants (TCEQ).
- J. Surface water: all water naturally open to the atmosphere (rivers, lakes, reservoirs, ponds, streams, seas, estuaries), and all springs, wells, and other collectors directly influenced by surface water (TCEQ).
- K. Turbidity: a condition of water quality characterized by the presence of suspended solids and/or organic material (EPA).
- L. Uncontaminated discharge: a discharge that does not cause or contribute to an exceedance of applicable water quality standards (EPA).
- M. Unwater: the act of draining pond water, rainwater, and/or groundwater from ponds, building foundations, vaults, and trenches (EPA).

1.4 WORK COVERED BY CONTRACT DOCUMENTS

- A. Project Identification: Winnwood Pond Dredging Project.
 - 1. Project Location: Three ponds directly south of Belt Line Road between Oaks North Drive and Winnwood Road in Addison, Texas.
- B. Owner: Town of Addison
- C. Engineer: Halff Associates, Inc. 12225 Greenville Avenue, Suite 200 Dallas, TX 75243
- D. The Work generally consists of the following:
 - 1. Mobilization and Demobilization.
 - 2. To extents indicated on the Drawings, removal of existing:
 - a. Sediment.
 - b. Brush, limbs, and trash.
 - c. Concrete box fountains.
 - d. Submersible fountain pumps.
 - e. Storm drain piping.
 - f. Electrical wiring.
 - g. Sidewalk, as necessary.
 - 3. Install temporary facilities, including but not limited to barriers (cofferdams, dikes, berms, etc.), unwatering and water diversion mechanisms, sediment dewatering, construction roads and staging areas.
 - 4. Develop and implement traffic control plan.
 - 5. Develop and implement erosion control provisions and a Stormwater Pollution Prevention Plan.
 - 6. Develop and implement sequencing plan.
 - 7. Develop and implement unwatering, bypass pumping, dewatering, and disposal plans.
 - 8. Trim trees.
 - 9. Relocate aquatic wildlife. (By aquatic resource specialists; Contractor shall assist.)
 - 10. Pour flowable fill concrete in storm drain trench and submersible fountain pump shaft.
 - 11. Install and remove bypass pumps and piping.
 - 12. Install turf reinforcement mat and sod.
 - 13. Dispose of dewatered silt.

14. Remove all temporary facilities and construction. Restore sidewalk and grass and wood chips.
15. Test irrigation system. (By Town of Addison; Contractor shall assist.)
16. Test pump recirculation systems. (By Town of Addison; Contractor shall assist.)

1.5 WORK PHASES

- A. The Work shall be phased in a manner that achieves the following goals:
 1. Minimize the time that the ponds are empty.
 2. Maintain the safety of trail users and separate them from work areas.
 3. Do not close any sidewalk for more than 6 weeks at a time.
- B. Suggested Construction Sequencing
 - Phase 1 – Submittals
 1. Prepare Submittals and submit for approval.
 - Phase 2 – Traffic Control Plan
 1. Install traffic control.
 - Phase 3 – Aquatic Resource Relocation
 1. Coordinate with Aquatic Resource Specialists.
 2. Implement Aquatic Resource Relocation.
 - Phase 4 – Removal of Floating Fountains and Sprinkler Heads
 1. Remove floating fountains.
 2. Remove sprinkler heads in construction areas.
 - Phase 5 – Desilt Pond 1
 1. Block normal low flow from entering Pond 1.
 2. Install a bypass route directing filtered, uncontaminated water that meets the TPDES General Permit No. TXR 150000, issued February 19, 2013, restrictions from upstream of the bridge at the northwest Pond 1 limits to creek downstream of Pond 3.
 3. Coordinate with Aquatic Resource Specialists for removal of aquatic wildlife.
 4. Unwater Pond 1. Pump uncontaminated water that meets the TPDES General Permit No. TXR 150000, issued February 19, 2013, restrictions to the creek downstream of Pond 3. Properly dispose of contaminated water.
 5. Remove silt.
 6. Dewater and dispose of silt at permitted landfill.
 7. Demolish fountain and appurtenances.
 8. Remove bypass and temporary dam.
 - Phase 6 – Desilt Pond 2
 1. Block normal low flow from entering Pond 2.
 2. Install a bypass route directing filtered, uncontaminated water that meets the TPDES General Permit No. TXR 150000, issued February 19, 2013, restrictions from the unnamed tributary upstream of Pond 2 to creek downstream of Pond 3.
 3. Coordinate with Aquatic Resource Specialists for removal of aquatic wildlife.
 4. Unwater Pond 2. Pump uncontaminated water that meets the TPDES General Permit No. TXR 150000, issued February 19, 2013, restrictions to the creek downstream of Pond 3. Properly dispose of contaminated water.
 5. Dewater and dispose of silt at permitted landfill.
 6. Demolish fountain and appurtenances.
 7. Remove bypass and temporary dam.
 - Phase 7 – Desilt Pond 3
 1. Block normal low flow from entering Pond 3.

2. Install a bypass route directing filtered, uncontaminated water that meets the TPDES General Permit No. TXR 150000, issued February 19, 2013, restrictions from Pond 2 to creek downstream of Pond 3.
3. Coordinate with Aquatic Resource Specialists for removal of aquatic wildlife.
4. Unwater Pond 3. Pump uncontaminated water that meets the TPDES General Permit No. TXR 150000, issued February 19, 2013, restrictions to the creek downstream of Pond 3. Properly dispose of contaminated water.
5. Remove silt.
6. Dewater and dispose of silt at permitted landfill.
7. Demolish fountain and appurtenances.
8. Remove bypass and temporary dam.

Phase 8 – Demobilization

1. Reinstall floating fountains.
2. Request the Town to test existing pumps and electrical systems.
3. Reinstall sprinkler heads.
4. Request Town to test existing sprinkler system.
5. Remove equipment and materials.
6. Install sod and wood chips as necessary.

1.6 USE OF PREMISES

- A. Limit use of premises to work in areas indicated. Do not disturb portions of Project site beyond areas in which the Work is indicated.
1. Limits: Confine constructions operations to City property and public rights of way unless approved by Owner.
 - a. Limit site disturbances to areas immediately surrounding the proposed improvements as indicated on the Drawings.
 - b. No construction activity or site disturbances shall occur on:
 - 1) Oaks North Drive, Lake Forest Drive, or Winnwood Road south of construction limits. No staging on roadways.
 - 2) Private property unless approved by the owner.
 - 3) Town of Addison property outside construction limits unless approved by the Town.
 - c. No construction vehicles shall be allowed on:
 - 1) Oaks North Drive, Lake Forest Drive, or Winnwood Road south of construction limits. No staging on roadways.
 - 2) Private property unless approved by the owner.
 - 3) Town of Addison property outside construction limits unless approved by the Town.
 2. Existing trees shall not be removed unless indicated on the Drawings. Note that not all existing trees are shown on the Drawings. Trees not shown shall remain unless approved by the Engineer.
 3. Traffic Control
 - a. Barricading and traffic control during construction shall be the responsibility of the Contractor and shall conform to the Texas Manual of Uniform Traffic Control Devices (TMUTCD).
 - b. Traffic flow and access shall be maintained during all phases of the work. Access shall be provided to all businesses and residences at all times during the work.
 - c. Street access shall be maintained at all times for emergency vehicles.
 4. Pedestrian trail

- a. Only one segment of the pedestrian trail shall be closed at a time and for no more than 60 days.
 - b. Maintain proper barricades and fencing to separate trail traffic from construction areas.
5. Driveways and Entrances: Driveways may not be closed to the public at any time. The Contractor shall maintain the entrances and make them available to Owner, Owner's employees, and emergency vehicles at all times.
- a. Schedule deliveries to minimize impacts to drives and pedestrian trail.
 - b. Schedule deliveries to minimize space and time requirements for storage of materials and equipment on-site.

1.7 WORK RESTRICTIONS

- A. On-Site Work Hours: Construction may only occur from 7 a.m. to 7 p.m. Monday through Friday and from 8 a.m. to 7 p.m. on Saturdays. No work shall occur on Sundays.
- B. The Contractor is permitted to request approval to exceed the normal work hours outlined in Part 1.7.A. However, the Contractor must present a detailed work schedule to obtain written approval from the Town.
- C. The Contractor shall comply and cooperate with the Park Department and other Town and non-Town agencies in the planning of park events potentially impacted by construction under this contract. The Contractor shall provide construction schedules and inform event organizers of potential impacts due to construction.
- D. Existing Utility Interruptions: Do not interrupt utilities serving facilities occupied by Owner or others unless permitted under the following conditions and then only after arranging to provide temporary utility services according to requirements indicated:
 1. Notify Construction Manager and Owner of utility not less than two days in advance of proposed utility interruptions.
 2. Do not proceed with utility interruptions without Utility Owner's written permission.

1.8 MISCELLANEOUS PROVISIONS

- A. Completion of the work shall be determined by the Owner.

PART 2 - PRODUCTS

(Not Used)

PART 3 - EXECUTION

(Not Used)

END OF SECTION

SECTION 01330

SUBMITTAL PROCEDURES

PART 1 GENERAL

1.1 SUMMARY

- A. Section includes requirements for the submittal schedule and administrative and procedural requirements for submitting Shop Drawings, Product Data, Samples, and other submittals.

1.2 DEFINITIONS

- A. Action Submittals: Written and graphic information and physical samples that require Engineer's responsive action.
- B. Informational Submittals: Written and graphic information and physical samples that do not require Engineer's responsive action. Submittals may be rejected for not complying with requirements.

1.3 SUBMITTAL ADMINISTRATIVE REQUIREMENTS

- A. Coordination: Coordinate preparation and processing of submittals with performance of construction activities.
 - 1. Coordinate each submittal with fabrication, purchasing, testing, delivery, other submittals, and related activities that require sequential activity.
 - 2. Coordinate transmittal of different types of submittals for related parts of the Work so processing will not be delayed because of need to review submittals concurrently for coordination.
 - a. Engineer reserves the right to withhold action on a submittal requiring coordination with other submittals until related submittals are received.
- B. Processing Time: Allow time for submittal review, including time for resubmittals, as follows. Time for review shall commence on Engineer's receipt of submittal. No extension of the Contract Time will be authorized because of failure to transmit submittals enough in advance of the Work to permit processing, including resubmittals.
 - 1. Initial Review: Allow 14 days for initial review of each submittal. Allow additional time if coordination with subsequent submittals is required. Engineer will advise Contractor when a submittal being processed must be delayed for coordination.
 - 2. Intermediate Review: If intermediate submittal is necessary, process it in same manner as initial submittal.
 - 3. Resubmittal Review: Allow 14 days for review of each resubmittal.
- C. Electronic Submittals: Identify and incorporate information in each electronic submittal file as follows:
 - 1. Assemble complete submittal package into a single indexed file incorporating submittal requirements of a single Specification Section and transmittal form with links enabling navigation to each item.

2. Name file with submittal number or other unique identifier, including revision identifier.
 - a. File name shall use Specification Section number followed by a decimal point and then a sequential number (e.g., 01330.01). Resubmittals shall include an alphabetic suffix after another decimal point (e.g., 01330.01.A).
 3. Provide means for insertion to permanently record Contractor's review and approval markings and action taken by Engineer.
 4. Transmittal Form for Electronic Submittals: Use electronic form acceptable to Owner, containing the following information:
 - a. Project name.
 - b. Date.
 - c. Name and address of Engineer.
 - d. Name of Contractor.
 - e. Name of firm or entity that prepared submittal.
 - f. Names of subcontractor, manufacturer, and supplier.
 - g. Category and type of submittal.
 - h. Submittal purpose and description.
 - i. Specification Section number and title.
 - j. Specification paragraph number or drawing designation and generic name for each of multiple items.
 - k. Drawing number and detail references, as appropriate.
 - l. Related physical samples submitted directly.
 - m. Indication of full or partial submittal.
 - n. Submittal and transmittal distribution record.
 - o. Other necessary identification.
- D. Options: Identify options requiring selection by Engineer.
- E. Deviations: Identify deviations from the Contract Documents on submittals.
- F. Resubmittals: Make resubmittals in same form and number of copies as initial submittal.
 1. Note date and content of previous submittal.
 2. Note date and content of revision in label or title block and clearly indicate extent of revision.
 3. Resubmit submittals until they are marked with approval notation from Engineer's action stamp.
- G. Distribution: Furnish copies of final submittals to manufacturers, subcontractors, suppliers, fabricators, installers, authorities having jurisdiction, and others as necessary for performance of construction activities. Show distribution on transmittal forms.
- H. Use for Construction: Retain complete copies of submittals on Project site. Use only final action submittals that are marked with approval notation from Engineer's action stamp.

1.4 SUBMITTAL SCHEDULE

Items requiring a formal submittal include but are not necessarily limited to the following:

1. Construction Schedule
2. Schedule of Values of all Bid Items
3. Schedule of Values for Draw Requests

4. Site Work & Associated Work
5. Cast-in-Place Concrete and Reinforcing Steel
6. Pre-Construction Project Video
7. Quality Control Plan
8. Traffic Control Plan
9. Construction Sequencing Plan
10. Proposed Staging Area Plan
11. Bypass Pumping Plan
12. Unwatering Plan
13. Haul Route Plan
14. Construction Entrance/Road Layout Plan
15. Trench Safety Plan
16. Dewatering System Plan
17. Silt Disposal Plan
18. Contaminated Water Disposal Plan
19. Pollution Control Plan
20. Spill Containment Contingency Plan
21. Copies of SW3P, NOI, and NOT
22. Testing Reports
23. Post Desilting Survey
24. Any other items which the Contractor wishes confirmation from the Engineer as to the appropriateness of application and suitability for incorporation into the project.

PART 2 PRODUCTS

2.1 SUBMITTAL PROCEDURES

- A. General Submittal Procedure Requirements:
 1. Submit electronic submittals via email as PDF electronic files.
- B. Product Data: Collect information into a single submittal for each element of construction and type of product or equipment.
 1. If information must be specially prepared for submittal because standard published data are not suitable for use, submit as Shop Drawings, not as Product Data.
 2. Mark each copy of each submittal to show which products and options are applicable.
 3. Include the following information, as applicable:
 - a. Manufacturer's catalog cuts.
 - b. Manufacturer's product specifications.
 - c. Standard color charts.
 - d. Statement of compliance with specified referenced standards.
 - e. Testing by recognized testing agency.
 - f. Application of testing agency labels and seals.
 - g. Notation of coordination requirements.
 - h. Availability and delivery time information.
 4. Submit Product Data before or concurrent with Samples.
 5. Submit Product Data in the following format:
 - a. PDF electronic file.

- C. Shop Drawings: Prepare Project-specific information, drawn accurately to scale. Do not base Shop Drawings on reproductions of the Contract Documents or standard printed data.
1. Preparation: Fully illustrate requirements in the Contract Documents. Include the following information, as applicable:
 - a. Identification of products.
 - b. Schedules.
 - c. Compliance with specified standards.
 - d. Notation of coordination requirements.
 - e. Notation of dimensions established by field measurement.
 - f. Relationship and attachment to adjoining construction clearly indicated.
 2. Sheet Size: Except for templates, patterns, and similar full-size drawings, submit Shop Drawings on sheets at least 8-1/2 by 11 inches, but no larger than 30 by 42 inches.
 3. Submit Shop Drawings in the following format:
 - a. PDF electronic file.
- D. Samples: Submit Samples for review of kind, color, pattern, and texture for a check of these characteristics with other elements and for a comparison of these characteristics between submittal and actual component as delivered and installed.
1. Transmit Samples that contain multiple, related components such as accessories together in one submittal package.
 2. Identification: Attach label on unexposed side of Samples that includes the following:
 - a. Generic description of Sample.
 - b. Product name and name of manufacturer.
 - c. Sample source.
 - d. Number and title of applicable Specification Section.
 3. For projects where electronic submittals are required, provide corresponding electronic submittal of Sample transmittal, digital image file illustrating Sample characteristics, and identification information for record.
 4. Disposition: Maintain sets of approved Samples at Project site, available for quality-control comparisons throughout the course of construction activity. Sample sets may be used to determine final acceptance of construction associated with each set.
 - a. Samples that may be incorporated into the Work are indicated in individual Specification Sections. Such Samples must be in an undamaged condition at time of use.
 - b. Samples not incorporated into the Work, or otherwise designated as Owner's property, are the property of Contractor.
 5. Samples for Verification: Submit full-size units or Samples of size indicated, prepared from same material to be used for the Work, cured and finished in manner specified, and physically identical with material or product proposed for use, and that show full range of color and texture variations expected. Samples include, but are not limited to, the following: partial sections of manufactured or fabricated components; small cuts or containers of materials; complete units of repetitively used materials; swatches showing color, texture, and pattern; color range sets; and components used for independent testing and inspection.

- a. Number of Samples: Submit three sets of Samples. Engineer will retain two Sample sets; remainder will be returned. Mark up and retain one returned Sample set as a project record sample.
 - 1) If variation in color, pattern, texture, or other characteristic is inherent in material or product represented by a Sample, submit at least three sets of paired units that show approximate limits of variations.
- E. Test and Inspection Reports and Schedule of Tests and Inspections Submittals: Comply with requirements specified in Section 01400 Quality Control.
- F. Qualification Data: Prepare written information that demonstrates capabilities and experience of firm or person. Include lists of completed projects with project names and addresses, contact information of Engineers and owners, and other information specified. Refer to Section PQ, "Prequalification Statement".
- G. Insert definition of Contractor certificates here if required by individual Specification Sections. See Evaluations.
- H. Installer Certificates: Submit written statements on manufacturer's letterhead certifying that Installer complies with requirements in the Contract Documents and, where required, is authorized by manufacturer for this specific Project.
- I. Manufacturer Certificates: Submit written statements on manufacturer's letterhead certifying that manufacturer complies with requirements in the Contract Documents. Include evidence of manufacturing experience where required.
- J. Product Certificates: Submit written statements on manufacturer's letterhead certifying that product complies with requirements in the Contract Documents.
- K. Material Certificates: Submit written statements on manufacturer's letterhead certifying that material complies with requirements in the Contract Documents.
- L. Material Test Reports: Submit reports written by a qualified testing agency, on testing agency's standard form, indicating and interpreting test results of material for compliance with requirements in the Contract Documents.
- M. Product Test Reports: Submit written reports indicating that current product produced by manufacturer complies with requirements in the Contract Documents. Base reports on evaluation of tests performed by manufacturer and witnessed by a qualified testing agency, or on comprehensive tests performed by a qualified testing agency.
- N. Research Reports: Submit written evidence, from a model code organization acceptable to authorities having jurisdiction, that product complies with building code in effect for Project.
- O. Schedule of Tests and Inspections: Comply with requirements specified in Section 014000 Quality Control.
- P. Preconstruction Test Reports: Submit reports written by a qualified testing agency, on testing agency's standard form, indicating and interpreting results of tests performed

before installation of product, for compliance with performance requirements in the Contract Documents.

- Q. Compatibility Test Reports: Submit reports written by a qualified testing agency, on testing agency's standard form, indicating and interpreting results of compatibility tests performed before installation of product. Include written recommendations for primers and substrate preparation needed for adhesion.
- R. Field Test Reports: Submit written reports indicating and interpreting results of field tests performed either during installation of product or after product is installed in its final location, for compliance with requirements in the Contract Documents.
- S. Design Data: Prepare and submit written and graphic information, including, but not limited to, performance and design criteria, list of applicable codes and regulations, and calculations. Include list of assumptions and other performance and design criteria and a summary of loads. Include load diagrams if applicable. Provide name and version of software, if any, used for calculations. Include page numbers.

PART 3 EXECUTION

3.1 CONTRACTOR'S REVIEW

- A. Action and Informational Submittals: Review each submittal and check for coordination with other Work of the Contract and for compliance with the Contract Documents. Note corrections and field dimensions. Mark with approval stamp before submitting to Engineer.
- B. Approval Stamp: Stamp each submittal with a uniform, approval stamp. Include Project name and location, submittal number, Specification Section title and number, name of reviewer, date of Contractor's approval, and statement certifying that submittal has been reviewed, checked, and approved for compliance with the Contract Documents.

3.2 ENGINEER'S ACTION

- A. General: Engineer will not review submittals that do not bear Contractor's approval stamp and will return them without action.
- B. Action Submittals: Engineer will review each submittal, make marks to indicate corrections or revisions required, and return it. Engineer will stamp each submittal with an action stamp and will mark stamp appropriately to indicate action.
- C. Informational Submittals: Engineer will review each submittal and will not return it, or will return it if it does not comply with requirements. Engineer will forward each submittal to appropriate party.
- D. Incomplete submittals are unacceptable, will be considered nonresponsive, and will be returned for resubmittal without review.
- E. Submittals not required by the Contract Documents may not be reviewed and may be discarded.

END OF SECTION

SECTION 01395

TRENCH SAFETY

PART 1 - GENERAL

1.1 RELATED DOCUMENTS

- A. Drawing - Drawings and general provisions of the Contract, including General and Supplementary Conditions and other Division 1 Specification Sections, apply to this Section.

1.2 SUMMARY

- A. Work in this section shall consist of furnishing all equipment, materials and labor for a trench safety system meeting appropriate requirements established in Occupational Safety and Health Administration (OSHA) Safety and Health Regulations, Part 1926, Subpart P- Excavations, Trenching and Shoring. Related Referenced Sections include the following:
 - B. Referenced Sections include the following:
 - 1. Section 02300 Earthwork for Pavements, Trails and Slope Protection.
 - 2. Section 02212 Embankment and Earthwork for Structures.
 - 3. Section 02240 Dewatering.

1.3 SUBMITTALS

- A. Trench Safety Program
 - 1. After award of the contract and prior to construction start, the Contractor shall submit documentation of a Trench Safety Program to the Construction Manager. The submittal shall be type written and signed by an official of the construction company. It will contain sufficient information to ensure compliance with all OSHA requirements regarding trench safety.
 - 2. As a minimum, the trench safety program documentation must include the following items: A safety checklist; existing underground utilities; type of safety equipment required; supervisor's degree of responsibility and authority; employee training required; safety sessions notification and investigation of accidents; Safety Officer Inspections education requirements; individual equipment (safety shoes, safety glasses, hard hats, etc.).
- B. Trench Excavation Plan
 - 1. After award, the Contractor will be required to submit a trench excavation plan. This excavation plan must be designed and sealed by a Professional Engineer registered in the State of Texas with professional experience in soil mechanics. The Contractor is responsible for obtaining borings and soil analysis as required for plan design. The trench excavation plan is to be designed in conformance with OSHA and all other applicable Federal, State and Local standards and regulations.
 - 2. After review of the trench excavation plan, it will be forwarded to the appropriate construction division for use in inspection. No trenching in excess of 5 feet below existing grade will be allowed until this plan is reviewed. Any changes in the trench excavation plan after initiation of construction will not be cause for extension of time or change order, and

- will require the same review process. **Contractor accepts sole responsibility for compliance with all applicable safety standards.** The review is only for general conformance with OSHA safety standards. Review of the trench excavation plan does not relieve Contractor from any or all construction means, methods, techniques and procedures; and any property damage or bodily injury (including death) that arises from use of the trench excavation plan, shall remain the sole responsibility and liability of the Contractor.
3. Contractors have 3 ways to meet OSHA Standards for Trench Excavation, they are:
 - a. Minimum Angle of Repose for Sloping of the Sides of Excavations.
 - b. Utilization of Trench Box.
 - c. Shoring, Sheet piling and Bracing Methods.
 4. Contractors electing to utilize the Minimum Angle or Repose must submit:
 - a. Soil classification according to the Unified Soil Classification System including water content and plasticity index, and a minimum angle of the slope of excavation for the trench.
 - b. A detailed plan of the excavation area and the impact on existing right-of-way and infrastructure.
 - c. No separate additional pay item for this method is provided.
 - d. No claim for delay cost.
 5. Contractors electing to utilize a Trench Box must submit:
 - a. Dimensions and materials of all uprights, stringers, cross-bracing and spacing required to meet OSHA requirements.
 - b. No separate additional pay item is provided for this work.
 - c. No claim for delay cost.
 6. Contractors electing to utilize Shoring, Sheet piling and Bracing methods must submit:
 - a. Sealed engineering plans for all constructed portions of the trench safety system.
 - b. No separate additional pay item is provided for this work.
 - c. No claim for delay cost.

PART 2 - PRODUCTS

2.1 TIMBER

- A. Trench sheeting materials shall be a minimum of 2 inches in thickness, solid and sound, free from weakening defects such as loose knots and splits.

2.2 STEEL SHEET PILING

- A. Steel sheet piling shall conform to one of the following specifications:
 1. ASTM A 328
 2. ASTM A 572, Grade 50
 3. ASTM A 690
 4. ASTM A 572, Grade 50
- B. Steel for stringers and cross braces shall conform to ASTM A 588.

2.3 PORTABLE TRENCH BOXES

- A. Portable trench boxes shall be constructed of steel conforming to ASTM A 307. Welds shall conform to requirements of AWS Specification D1.1.

PART 3 - EXECUTION

3.1 GENERAL

- A. Trench safety system shall be constructed, installed and maintained in accordance with the design prepared by the Contractor's registered Professional Engineer, licensed to practice in Texas, to prevent death or injury to personnel or damage to structures in or near the trench excavation. Materials excavated from trench to be stored no closer to the edge of trench than one-half the depth of the trench.

3.2 INSTALLATION

- A. Timber Sheeting
 - 1. Timber sheeting to be installed in accordance with trench system design and OSHA.
- B. Steel Sheet Piling
 - 1. Steel sheet piling of equal or greater strength may be substituted for timber trench shoring. Contractor to provide certification that steel sheet piling substituted provides equal or greater protection that timber trench shoring. Certification of steel sheet piling to be provided by registered Professional Engineer licensed to practice in Texas. Place cross bracing in true horizontal position, spaced vertically and secured to prevent sliding, falling, or kickouts.
- C. Trench Boxes
 - 1. Portable trench box to be substituted for timber trench shoring shall designed or the design checked by Contractor's registered Professional Engineer licensed to practice in Texas. Certification of design of trench boxes shall be provided by Contractor prior to its use on the project. In cases where top of portable trench box will be below the top of trench, the trench must be sloped to an angle greater than the angle of repose for the soil conditions existing on the project. In area where sloped trench will affect the integrity of existing structures, Contractor to protect structures prior to sloping trench.
- D. Trench Jacks
 - 1. When trench jacks are used for cross bracing and/or stringers, the Contractor shall provide certification by a registered Professional Engineer that the trench jacks provide protection greater than or equal the timber cross bracing.

3.3 SUPERVISION

- A. Contractor shall provide competent supervisory personnel at each trench while work is in progress to ensure Contractor's methods, procedures, equipment and materials pertaining to the safety system in this item are sufficient to meet requirements of OSHA Standards.

3.4 MAINTENANCE OF SAFETY SYSTEM

- A. The safety system shall be maintained in the condition as specified by the Contractor's registered Professional Engineer. The Contractor shall take all necessary precautions to ensure the safety systems are not damaged during their use. If at any time during its use a safety system is damaged, personnel shall be immediately removed from the trench or excavation area and the safety system repaired. The Contractor shall take all necessary precautions to ensure no loads, except those included in the safety system design, are imposed upon the excavation.

3.5 INSPECTION

- A. Contractor shall make daily inspection of trench safety system to ensure that the system meets OSHA requirements. Daily inspection to be made by competent personnel. If evidence of possible cave-ins or slides is apparent, all work in the trench shall cease until necessary precautions have been taken to safeguard personnel entering trench. Contractor to maintain permanent record of daily inspections.

3.6 REMOVAL

- A. Bed and backfill pipe to a point at least one foot above top of pipe prior to removal of any portion of trench safety system. Bedding and backfill to be in accordance to other applicable specification items. Backfilling and removal of trench supports shall progress together from bottom of trench upward. Remove no braces or trench supports until all personnel have evacuated the trench. Backfill trench to within 5 feet of natural ground prior to removal of entire trench safety system.

END OF SECTION

SECTION 01400
QUALITY CONTROL

PART 1 GENERAL

1.1 QUALITY ASSURANCE ACTIVITIES BY THE OWNER AND THE CONTRACTOR

Quality assurance activities of the Owner through their own forces or through contracts with materials testing laboratories and survey crews are for the purpose of monitoring the results of the Contractor's work to see that it is in compliance with the requirements of the Contract Documents. Failure on the part of the Owner or Engineer to perform or test products or constructed works in no way relieves the Contractor of the obligation to perform work and furnish materials conforming to the Contract Documents.

The Owner will pay for the following testing performed in the field: soil compaction, proctors, soil or aggregate gradations, and concrete sampling and testing. The Contractor shall provide testing for proposed materials such as backfill material types, gradations, concrete mix designs, and all other testing specified and not being performed by the Owner.

1.2 CONTRACTOR'S RESPONSIBILITIES

- A. Control the quality of work produced and verify that the work performed meets the standards of quality established in the Contract Documents.
 - 1. Inspect the work performed by the Contractor, subcontractors, and suppliers. Correct defective work.
 - 2. Inspect products to be incorporated into the project. Provide only those products that comply with the Contract Documents.
 - 3. Verify conformance of the work and products with the Contract Documents before notifying the Owner of need for testing.
 - 4. Provide consumable construction materials of adequate quality to provide a finished product that complies with the Contract Documents.
 - 5. Provide and pay for the service of an approved professional materials testing laboratory to insure that products proposed for use fully comply with the Contract Documents.
 - 6. Perform tests as indicated in this and other sections of the specifications. Schedule the time and sequence of testing with the Owner and Engineer. Testing is to be observed by the Owner, Engineer, or designated representative.
 - 7. Provide labor, materials, tools, equipment, and related items for testing by the Owner including, but not limited to temporary construction required for testing and operation of new and existing utilities.

- B. Provide Certified Test Reports as applicable on products or constructed works to be incorporated into the project as required by Section 01330, SUBMITTALS. Reports are to indicate that products or constructed works are in compliance with the Contract Documents.

- C. Provide and maintain a written Quality Control Program that establishes the methods of

assuring compliance with the Contract Documents.

- D. Designate Quality Control personnel at the start of the project. These personnel shall have the authority to monitor the work effectively and to implement and enforce the Quality Control program.
- E. Assist the Engineer, Owner, and Owner's testing organization to perform quality assurance activities.
 - 1. Provide access to the work and to the Manufacturer's operation at all times work is in progress.
 - 2. Cooperate fully in the performance of sampling, inspection, and testing.
 - 3. Furnish labor and facilities to:
 - a. Provide access to the work to be tested.
 - b. Obtain and handle samples for testing at the project site or at the source of the product to be tested.
 - c. Facilitate inspections and tests.
 - d. Store and cure test samples.
 - 4. Furnish copies of the tests performed on products.
 - 5. Provide adequate quantities of representative product to be tested to the laboratory at the designated location.
 - 6. Give the Owner adequate notice before proceeding with work that would interfere with testing.
 - 7. Notify the Engineer and the testing laboratory prior to the time that testing is required. Lead time is to be adequate to allow arrangements to be made for testing.
 - 8. Do not proceed with any work until testing services have been performed and results of tests indicate that the work is acceptable.
 - 9. Provide complete access to the site and make Contract Documents available.
 - 10. Provide personnel and equipment needed to perform sampling or to assist in making the field tests.
 - 11. Testing performed by the Owner will be paid for by the Owner. If tests fail, Contractor shall reimburse the Owner for cost of re-testing once corrections are made.
- F. Provide a recognized testing laboratory capable of performing a full range of testing procedures complying with the standards or testing procedures specified. Obtain Owner's approval for the testing laboratory before testing is performed.
- G. Provide personnel certified to perform the test required.
- H. Should requirements of this Section of the specification conflict with the requirements of the detailed specifications, the technical specifications shall govern.

1.3 SUBMITTALS

Submittals shall be in accordance with Section 01330, SUBMITTALS, and shall include:

- A. The name of the proposed testing laboratory along with documentation of qualifications, a list of tests that can be performed, and a list of recent projects for which testing has been performed with references from those projects.

- B. Test reports per Paragraph 1.07, TEST REPORTS of this specification.

1.4 STANDARDS

- A. Provide a testing laboratory that complies with the ACIL (American Council of Independent Laboratories) "Recommended Requirements for Independent Laboratory Qualifications".
- B. Perform testing per recognized test procedures as listed in the various sections of the specifications, standards of the State Department of Highways and Public Transportation, American Society of Testing Materials (ASTM), or other testing associations. Perform tests in accordance with published procedures for testing issued by these organizations.

1.5 DELIVERY AND STORAGE

Handle and protect test specimens of products and construction materials at the construction site in accordance with recognized test procedures.

1.6 VERIFICATION TESTING

- A. Provide verification testing when tests performed by the Owner indicate that materials or the results of construction activities are not in conformance with Contract Documents.
- B. Verification testing is to be provided at the Contractor's expense to verify products or constructed works are in compliance after corrections have been made.
- C. Tests must comply with recognized methods or with methods recommended by the Owner's testing laboratory and approved by the Engineer.

1.7 TEST REPORTS

- A. Test reports are to be prepared for all tests.
 - 1. Tests performed by testing laboratories may be submitted on their standard test report forms. These reports must include the following:
 - a. Name of the Owner, project title and number, equipment installer and general contractor.
 - b. Name of the laboratory, address, and telephone number.
 - c. Name and signature of the laboratory personnel performing the test.
 - d. Description of the product being sampled or tested.
 - e. Date and time of sampling, inspection, and testing.
 - f. Date the report was issued.
 - g. Description of the test performed.
 - h. Weather conditions and temperature at time of test or sampling.
 - I. Location at the site or structure where the test was taken.
 - j. Standard or test procedure used in making the test.
 - k. A description of the results of the test.
 - l. Statement of compliance or non-compliance with the Contract Documents.
 - m. Interpretations of test results, if appropriate.
 - 2. Submit reports on tests performed by Contractor or his suppliers.

1.8 NON-CONFORMING WORK

- A. Immediately correct any work that is not in compliance with the Contract Documents or submit a written explanation of why the work is not to be corrected immediately and when the corrective work will be performed.
- B. Payment for non-conforming work shall be withheld until work is brought into compliance with the Contract Documents.

1.9 LIMITATION OF AUTHORITY OF THE TESTING LABORATORY

- A. The testing laboratory representative are limited to providing consultation on the test performed and in an advisory capacity.
- B. The testing laboratory is not authorized to:
 - 1. Alter the requirements of the contract documents.
 - 2. Accept or reject any portion of the work.
 - 3. Perform any of the duties of the Contractor.
 - 4. Stop the work.

PART 2 PRODUCTS

2.1 TESTING APPARATUS

Furnish testing apparatus and related accessories necessary to perform the tests.

PART 3 EXECUTION

3.1 PROTECTIVE COATINGS

- A. NOT APPLICABLE

3.2 LEAKAGE TESTS FOR STRUCTURES

- A. NOT APPLICABLE

3.3 PIPING SYSTEMS

- A. NOT APPLICABLE

3.4 ELECTRICAL TESTING

- A. QUALIFICATIONS
 - 1. Unless otherwise specified, testing shall be performed by qualified personnel with a minimum of five (5) years' experience installing and testing electrical equipment and machinery.
 - 2. Except as permitted by the Owner, the firm and individuals performing the tests shall be "third party", not providing other services or materials, or otherwise related or affiliated with other contractors or suppliers for this project.
- B. REPORT FORMS
 - 1. The appropriate test report for the items being tested shall be completed in its

entirety. Listed data that is not applicable or cannot be obtained shall be noted "N/A" or documented with an explanation for the omission. Incomplete test forms will not be witnessed by the Owner or his representative and the test shall be required to be repeated before acceptance is granted. Substitute forms, when provided by the Engineer, shall require recording similar data and test equipment as that specified.

C. TEST EQUIPMENT

1. The testing firm or individuals shall provide and test equipment and materials necessary to perform the requested tests.
2. Test equipment and apparatus shall be appropriate for the full range and duration of the test to be performed.
3. The test operator shall demonstrate to the Owner or his representative that the test equipment is functioning properly, prior to the commencement of the test. If a failure of the test equipment should occur during any portion of a test, the test shall be suspended and the equipment repaired or replaced. The test shall then be repeated in its entirety or as otherwise required by the Owner or his representative.
4. A copy of the test equipment calibration certificate shall be provided to the owner prior to the commencement of the test. Most recent test equipment calibration dates shall not exceed six (6) months prior to the date of the test, and accuracy shall be traceable to the National Institute of Standards and Technology.

D. EXECUTION

1. If the circuit, equipment or machinery being tested does not pass, appropriate repairs or replacements shall be made and the test shall be repeated as directed by the Owner or his representative.
2. The general provisions of Section 01400-1.00 and other applicable sections of these specifications and plans regarding testing, shall apply to all tests. If test procedures or equipment conflicts occur between the various sections and/or Manufacturer's recommendations, the more rigid requirement shall prevail.

E. RECIRCULATION PUMPS

1. All remaining pumps and fountains and associated electrical wires shall be tested in front of the Town prior to acceptance of completion. Run the recirculation pumps for 4 hours on 4 different days with the Town and Engineer present. Vary pump speeds, if requested. Any deficiencies shall be fixed by the Contractor at no extra pay.

END OF SECTION

SECTION 01568
EROSION CONTROL

PART 1 GENERAL

1.1 WORK INCLUDED

- A. Furnish labor, materials, equipment and incidentals necessary to provide erosion and sediment control for the duration of the construction period including furnishing, installing and maintaining erosion and sediment control structures and procedures and the proper removal when no longer required.
- B. The intent of this specification is to provide guidelines for the Contractor to adhere to all State, Federal, and Local environmental regulations. It is also the intent to provide preventive measures to keep sediment from entering any storm water system, including open channels. It is the Contractor's responsibility to adhere to all State, Federal and Local requirements. While the Owner may require the Contractor to install erosion control devices during construction, this will in no way relieve the Contractor of his responsibility.
- C. The estimated items of temporary erosion control will be based on the work area needed for the construction of the proposed improvements. However, the Engineer may increase or decrease the quantity of these items as the need arises. The engineer may specify other materials and work as the need arises.
- D. Prior to the start of construction, the Contractor shall submit for approval his schedules for accomplishment of soil erosion control work and his plan to keep the area of exposed soil to a minimum. He shall also submit for acceptance his proposed method of soil erosion control on the construction site, and haul roads and material sources, and his plan for disposal of waste materials. No work shall be started until the soil-erosion control schedules and methods of operations have been reviewed and approved by the engineer.

1.2 QUALITY ASSURANCE

- A. Comply with applicable requirements of all governing authorities having jurisdiction. The Specifications and the Plans are not represented as being comprehensive, but rather to convey the intent to provide complete slope protection and erosion control for both the Owner's and adjacent property.
- B. Erosion control measures shall be established at the beginning of construction and maintained during the entire length of construction. On-site areas which are subject to severe erosion and off-site areas which are especially vulnerable to damage from erosion and/or sedimentation are to be identified and receive additional erosion control measures as directed by the Owner or the Engineer.
- C. All land-disturbing activities shall be planned and conducted to minimize the size of the area to be exposed at any one time and to minimize the time of exposure and off-site sedimentation damage.

- D. Surface water runoff originating upgrate of exposed area shall be controlled to reduce erosion and sediment loss during the period of exposure.
- E. When the increase in the peak rates and velocity of storm water runoff resulting from a land-disturbing activity is sufficient to cause accelerated erosion of the receiving ditch or stream, the Contractor shall install measures to control both the velocity and rate of release so as to minimize accelerated erosion and increased sedimentation of the stream as directed by the Owner or the Engineer.
- F. Waste or disposal areas and construction roads shall be located and constructed in a manner that will minimize the amount of sediment entering the streams.
- G. When work areas or material sources are located in or adjacent to live streams, such areas shall be separated by erosion control barriers to keep sediment from entering a flowing stream. Care shall be taken during the construction and removal of such barriers to minimize the muddying of a stream.
- H. All waterways shall be cleared, as soon as practicable, of falsework, piling, debris or other obstructions placed during construction operations that are not a part of the finished work.
- I. The Contractor shall take sufficient precautions to prevent pollution of streams, lakes and reservoirs with fuels, oils, bitumens, calcium chloride or other harmful materials. He shall conduct and schedule his operations so as to avoid or minimize siltation of streams, lakes and reservoirs.
- J. Qualified operator personnel must inspect the site at least once every 14 days and within 24 hours of a storm event of 0.5 inches or greater. As an alternative, an inspection can be conducted once every seven calendar days on a defined day. A decision on which method to use must be decided before work begins and must be followed throughout the project.

1.3 SUBMITTALS

- A. Submittals shall be in accordance with Section 01300, SUBMITTALS, and shall include:
 - 1. Manufacturer's Literature: Descriptive data of installation methods and procedures.
 - 2. Certificates: Manufacturer's certification that materials meet specification requirements.

1.4 STANDARDS [Not Used]

1.5 DELIVERY AND STORAGE [Not Used]

1.6 JOB CONDITIONS; CODES AND ORDINANCES

- A. Comply with the local codes and ordinances. If local codes and ordinances require more stringent or additional erosion and sediment control measures during construction, Contractor shall provide such measures.

1.7 OPTIONS [Not Used]

1.8 GUARANTEES [Not Used]

PART 2 PRODUCTS

- b. Type F. Short-term duration (Up to 2 Years)
Shear Stress (t_d) 1.0 to 2.0 lb./sq. ft.
 - c. Type G. Long-term duration (Longer than 2 Years)
Shear Stress (t_d) > 2.0 to < 5.0 lb./sq. ft.
 - d. Type H. Long-term duration (Longer than 2 Years)
Shear Stress (t_d) greater than 0 Equal to 5.0 lb./sq. ft.
- G. The Contractor has the option of selecting an approved turf reinforcement mat provided that selection conforms to Texas Department of Transportation (TxDOT) Standard Detail Sheet, Class 1 – Slope Protection.
- 2.2 MIXES [Not Used]
- 2.3 FABRICATIONS [Not Used]
- 2.4 MANUFACTURED PRODUCTS [Not Used]

PART 3 EXECUTION

- 3.1 PREPARATION [Not Used]
- 3.02 INSTALLATION
- A. TEMPORARY STRAW BALE DIKE
1. Straw bales shall be embedded a minimum of 4" and securely anchored using 2" x 2" wood stakes driven through the bales into the ground a minimum of 6". Straw bales are to be placed directly adjacent to one another leaving no gap between them.
 2. Bales shall be placed in a single row, lengthwise on proposed line, with ends of adjacent bales tightly abutting one another. In swales and ditches, the barrier shall extend to such a length that the bottoms of the end bales are higher in elevation than the top of the lowest middle bale. Additional bales shall be placed behind the first row where the bales abut each other. The additional bale is used to prevent unfiltered runoff from escaping between the bales.
 3. The excavated soil shall be backfilled against the barrier. Backfill shall conform to ground level on the downhill side and shall be built up to 4" above ground level on the uphill side. Loose straw shall be scattered over the area immediately uphill from a straw barrier.
- B. SILT FENCE
1. The purpose of a silt fence is to intercept and detain water-borne sediment from unprotected areas to a limited extent. The Contractor shall excavate a 6" by 6" trench for site fence bedding along the lower perimeters of the site where necessary to prevent sediment from entering any drainage system.

2. The Contractor shall install the silt fence in accordance with the manufacturer's recommendations and instructions. Silt fence is used during the period of construction near the perimeter of a disturbed area to intercept sediment while allowing water to percolate through. This fence shall remain in place until the disturbed area is permanently stabilized. Silt fence should not be used where there is a concentration of water in a channel or drainage way or where soil conditions prevent a minimum toe-in depth of 6" or installation of support post to depth of 12". Fabric shall overlap at abutting ends a minimum of 3' and shall be jointed such that no leakage or bypass occurs. If concentrated flow occurs after installation, corrective action must be taken such as placing rock berm in the areas of concentrated flow.

C. SAND BAG BERM

1. The purpose of a sandbag berm is to intercept sediment-laden water from disturbed areas such as construction in steam beds, create a retention pond, detain sediment and release water in sheet flow.
2. A temporary sand bag berm shall be installed across a channel or right of way in a developing or disturbed area and should be used when the contributing drainage area is greater than 5 acres. The berm shall be a minimum height of 18", measured from the top of the existing ground at the upslope toe to the top of the berm. The berm shall be sized to have a minimum width of 48" measured at the bottom of the berm and 18" measured at the top of the berm.
3. The sand bag berm shall be inspected after each rain. The sand bags shall be reshaped or replaced as needed during inspection. Additional inspections shall be made daily by the responsible party and when the silt reaches 6", the accumulated silt shall be removed and disposed of at an approved site in a manner that will not contribute to additional siltation. The sand bag berm shall be left in place until all upstream areas are stabilized and accumulated silt removed; removal must be done by hand.

D. SOIL RETENTION BLANKETS (TURF REINFORCEMENT MAT)

1. A soil retention blanket (SRB) is a geotextile or biodegradable fabric placed over disturbed areas to limit the effects of erosion due to rainfall impact and runoff across barren soil. Soil retention blankets are manufactured by a wide variety of vendors addressing a wide variety of conditions such as vegetation establishment and high velocity flow. Blankets are used in areas which are difficult to stabilize such as steep slopes, drainage swales or high pedestrian traffic areas.
2. The soil retention blanket, whether installed as slope protection or as flexible channel liner, shall be placed within 24 hours after seeding or sodding operations have been completed, or as approved by the Engineer. Prior to placing the blanket, the area to be covered shall be relatively free of all rocks or clods over 1-1/2" in maximum dimension and all sticks or other foreign material which will prevent the close contact of the blanket with the soil. The area shall be smooth and free of ruts and other depressions. If as a result of rain, the prepared bed becomes crusted or eroded or if any eroded places, ruts or depressions exist for any reason, the Contractor shall be required to rework the soil until it is smooth and to reseed or resod the area at the Contractor's expense.
3. Installation and anchorage of the soil retention blanket shall be in accordance with the manufacturer's recommendations.

E. PROTECTION OF BARE AREAS

1. Apply seeding and soil retention blanket to bare areas including new embankment areas, fills, stripped areas, graded areas or otherwise disturbed areas, which have a grade greater than 5% or which will be exposed for more than 30 days.

2. Bare working areas on which it is not practical or desirable to install seeding and soil retention blankets, as determined by the Engineer, such as areas under proposed building slabs, shall be temporarily sloped to drain at a minimum of 0.2% and a maximum of 5% grade. These areas shall then be "trackwalked" with a crawler dozer traveling up and down the slope to form the effect of small "terraces" with the tracks of the dozer. Apply a minimum of three (3) coverages to each area with the dozer tracks.
3. Route runoff from the areas through the appropriate silt fence system.
4. Protect earth spoil areas by "trackwalking" and silt fences.

F. INTERCEPTOR SWALE

1. Interceptor swales may have a v-shape or be trapezoidal with a flat bottom and side slopes of 3:1 or flatter. These are used to shorten the length of exposed slope by intercepting runoff and can also serve as perimeter swales preventing off-site runoff from entering the disturbed area or prevent sediment-laden runoff from leaving the construction site or disturbed area. The outflow from a swale must be directed to a stabilized outlet or sediment trapping device. The swales should remain in place until the disturbed area is permanently stabilized.
2. Stone Stabilization shall be used when grades exceed 2% or velocities exceed 6' per second and shall consist of a layer of crushed stone 3" thick, or flexible channel liner soil retention blankets. Stabilization shall extend across the bottom of the swale and up both sides of the channel to minimum height of 3" above the design water surface elevation based on a two year storm.
3. Interceptor swale shall be installed across exposed slopes during construction and should intercept no more than five (5) acres of runoff. Swales shall have a minimum bottom width of 2'-0" and a maximum depth of 1'-6" with side slopes of 3:1 or flatter. Swale must have positive drainage for its entire length to an outlet. When the slope exceeds 3%, or velocities exceed 4' per second (regardless of slope), stone stabilization is required. Check dams are also recommended to reduce velocities in the swales possibly reducing the amount of stabilization necessary. Swales should be inspected on a weekly basis during wet weather and repairs should be made promptly to maintain a consistent cross section.
4. All trees, brush, stumps, obstructions and other material shall be removed and disposed of so as not to interfere with the proper functioning of the swale.
5. The swale shall be excavated or shaped to line, grade, and cross-section as required to meet criteria specified herein and be free of bank projections or other irregularities which will impede normal flow.
6. All earth removed and not needed in construction shall be disposed of in an approved spoils site so that it will be conveyed to a sediment trapping device.
7. Diverted runoff from a disturbed or exposed upland area shall be conveyed to a sediment trapping device.
8. The on-site location may need to be adjusted to meet field conditions in order to utilize the most suitable outlet.
9. Minimum compaction for the swale shall be 90% standard proctor.

G. SILT CURTAINS

1. Silt curtains shall be used as necessary in areas of active excavation to prevent silt plumes.
2. Refer to TxDOT Special Specification 5538, "Floating Turbidity Barrier".

H. LOCATION OF EROSION AND SEDIMENT CONTROL STRUCTURES

1. Locate erosion and sediment control structures as required to prevent erosion and removal of sediment from the project site. Silt fences shall be required for disturbed areas and soil stockpiles/spoil areas. Each silt fence installation shall have a minimum net length (exclusive of embedments into diversion dikes or other ineffective areas) of 25'. The runoff from a maximum of one (1) acre of disturbed area or soil stockpile/ spoil area shall be routed through any individual silt fence installation.
2. Install diversion dikes to divert runoff to the silt fence installation.
3. Install silt traps at the inlet (upstream) end of the drainage structures, including open channels, through which runoff from disturbed areas or soil stockpiles/spoil areas may drain.
4. Provide an overall erosion and sediment control system which protects disturbed areas and soil stockpiles/spoil areas. The system shall be modified by the Contractor from time to time to effectively control erosion and sediment during construction.

3.3 MAINTENANCE

- A. Maintain erosion and sediment control structures and procedures in full working order at all times during construction. This shall include any necessary repair or replacement of items which have become damaged or ineffective. Remove sediment on a regular basis which accumulates in sediment control devices and place the material in approved earth spoil areas or return the material to the area from which it eroded.
- B. Upon completion of construction, properly remove the temporary erosion and sediment control structures and complete the area as indicated.
- C. Soil retention blankets will not require removal if installed on a finished graded area specified to receive seeding.

3.4 FIELD QUALITY CONTROL

- A. In the event of conflict between the requirements and storm water pollution control laws, rules or regulations or other Federal, State or Local agencies, the more restrictive laws, rules or regulations shall apply.

END OF SECTION

SECTION 01710
SITE CLEARING AND ADJUSTING

PART 1 Progress Cleaning and Maintenance

- A. General: Clean project site and work areas, including common areas. Collect and dispose of waste materials at least daily.
 - 1. Comply with requirements in NFPA 241 for removal of combustible waste materials and debris.
 - 2. Do not hold materials more than 7 days during normal weather or 3 days if the temperature is expected to rise above 80 deg F.
 - 3. Containerize hazardous and unsanitary waste materials separately from other waste. Mark containers appropriately and dispose of legally, according to regulations.

- B. Site:
 - 1. Maintain the project site free of waste materials and debris.
 - 2. Maintain the project site such that the Contractor's work and temporary facilities do not pose a safety hazard to local residents, traffic, or park users. Install signs, barricades, fencing and other warning and security devices, whether shown on the plans or not, where safety issues exist or where directed by the Owner.
 - 3. The Contractor shall be responsible for mowing the grass on City Park property behind bypass pipes from the time the pipes are installed until they are removed. The mowing frequency shall be as directed by the Town of Addison, but not more frequent than once every week.

- C. Work Areas: Clean areas where work is in progress to the level of cleanliness necessary for proper execution of the Work.
 - 1. Remove liquid spills promptly.
 - 2. Store materials in a central, secure location.

- D. Exposed Surfaces in Finished Areas: Clean exposed surfaces and protect as necessary to ensure freedom from damage and deterioration at time of Substantial Completion.

- E. Waste Disposal: Dispose of materials lawfully. Burying or burning waste materials on-site will not be permitted. Washing waste materials down sewers or into waterways will not be permitted.

- F. During handling and installation, clean and protect construction in progress and adjoining materials already in place. Apply protective covering where required to ensure protection from damage or deterioration at Substantial Completion.

- G. Limiting Exposures: Supervise construction operations to assure that no part of the construction, completed or in progress, is subject to harmful, dangerous, damaging, or otherwise deleterious exposure during the construction period.

PART 2 Correction of the Work

- A. Repair or remove and replace defective construction. Restore damaged substrates and finishes.
 - 1. Repairing includes replacing defective components, refinishing damaged surfaces, touching up with matching materials, and properly adjusting operating components.
- B. Restore permanent facilities used during construction to their pre-construction condition.
 - 1. Remove all temporary facilities and control, including but not limited to bypass equipment, erosion control devices, odor control system, signs and barricades.
- C. Remove and replace damaged pavement in accordance with the Construction Plans and City requirements.
- D. All disturbed non-paved areas shall be finished to grade, smoothed with a suitable cement free topsoil (two-inches minimum) and covered with grass sod.
- E. Any disturbance or damage to private property shall be repaired to the satisfaction of the Owner.

PART 3 Payment

- A. Regular and final cleaning, as well as repair of damaged improvements, shall be considered incidental and shall not result in additional payment. The lump sum price for grading and sodding of disturbed areas shall include, but not be limited to, furnishing and installing all materials, and establishing the sod for a period of 90 days and a warranty period of one year.

END OF SECTION

SECTION 01732

DEMOLITION

PART 1 - GENERAL

1.1 RELATED DOCUMENTS

- A. Drawings and general provisions of the Contract, including General and Supplementary Conditions and other Specification Sections, apply to this Section.

1.2 SUMMARY

- A. This Section includes the following:
 - 1. Selective Demolition.
 - 2. Disposal of Demolished materials.
 - 3. Demolition Schedule.
- B. Related Sections include the following:
 - 1. Section 01710 Site Clearing and Adjusting.

1.3 DEFINITIONS

- A. Demolish: Completely remove and legally dispose of off-site.
- B. Remove: Detach items from existing construction and legally dispose of them off-site, unless indicated to be removed and salvaged or removed and reinstalled.
- C. Remove and Salvage: Detach items from existing construction and deliver them to the Owner at a location designated by the Owner.
- D. Remove and Reinstall: Detach items from existing construction, prepare them for reuse, and reinstall them where indicated.
- E. Existing to Remain: Existing items of construction that are not to be removed and that are not otherwise indicated to be removed, removed and salvaged, or removed and reinstalled.

1.4 MATERIALS OWNERSHIP

- A. Historic items, relics, and similar objects including, but not limited to monuments, commemorative plaques and tablets, and other items of interest or value to Owner that may be encountered during demolition remain Owner's property. Carefully remove and salvage each item or object in a manner to prevent damage and deliver promptly to Owner.

1.5 PROJECT CONDITIONS

- A. Storage or sale of removed items or materials on-site is not permitted.

- B. Utility Service: Maintain existing utilities indicated to remain in service and protect them against damage during demolition operations.

PART 2 - PRODUCTS

(Not Used)

PART 3 - EXECUTION

3.1 EXAMINATION

- A. Inventory and record the condition of items to be removed and reinstalled and items to be removed and salvaged.

3.2 PREPARATION

- A. Site Access and Temporary Controls: Conduct demolition and debris-removal operations to ensure minimum interference with roads, streets, walks, walkways, and other adjacent occupied and used facilities.
- B. Temporary Shoring: Provide and maintain shoring, bracing, and supports as required to preserve stability and prevent movement, settlement, or collapse of unprotected slopes, construction and items to remain, and to prevent unexpected or uncontrolled movement or collapse of construction being demolished.
 - 1. Strengthen or add new supports when required during progress of demolition.
 - 2. Refer to the Trench Safety Specification for further details.

3.3 DEMOLITION, GENERAL

- A. General:
 - 1. Locate demolition equipment and remove debris and materials.
 - 2. Dispose of demolished items and materials promptly.
- B. Existing Utilities: Abandon existing utilities and below-grade utility structures as indicated on the Drawings.
- C. Removed and Salvaged Items:
 - 1. Clean salvaged items.
 - 2. Store items in a secure area until delivery to Owner.
 - 3. Transport items to Owner's storage indicated on Drawings or as designated by Owner.
 - 4. Protect items from damage during transport and storage.
- D. Removed and Reinstalled Items:
 - 1. Clean and repair items to functional condition adequate for intended reuse. Paint equipment to match new equipment.
 - 2. Protect items from damage during transport and storage.
 - 3. Reinstall items in locations indicated. Comply with installation requirements for new materials and equipment. Provide connections, supports, and miscellaneous materials necessary to make item functional for use indicated.

- E. Existing Items to Remain: Protect construction indicated to remain against damage and soiling during demolition. When permitted by Engineer, items may be removed to a suitable, protected storage location during demolition and reinstalled in their original locations after demolition operations are complete.
- F. Explosives: Use of explosives is not permitted.

3.4 SELECTIVE DEMOLITION PROCEDURES FOR SPECIFIC MATERIALS

- A. Concrete Box Fountains and Piping: Demolish in sections, removing entire structure, including lights, wires, and piping, to two feet below the pond bottom. Cut along perimeter of area to be demolished, then break up and remove, being careful not to damage the surrounding pond bottom to remain. Use cutting methods least likely to damage construction to remain or adjoining construction. Plug the ends of remaining pipe.
- B. Fountain Lights and Electrical Wiring: Remove lights for concrete box fountains and remove cord set or conduit and wiring from lights to control panel without disruption to remaining electrical systems. Deliver to the Town.
- C. Submersible Fountain Pumps : Disconnect or cut the 4" and 12" pipes connecting to the submersible pumps. Remove the pumps and deliver to the Town. Use cutting and removal methods least likely to damage construction to remain or the submersible pumps. Plug the end of remaining pipe. Close 12" valve and fill shaft with flowable fill concrete as indicated on the demolition plan.
- D. Concrete Slabs-on-Grade: Saw-cut perimeter of area to be demolished, then break up and remove, being careful not to damage surrounding concrete to remain. Use cutting methods least likely to damage construction to remain or adjoining construction. Use hand tools or small power tools designed for sawing or grinding, not hammering and chopping, to minimize disturbance of adjacent surfaces.

3.5 DISPOSAL OF DEMOLISHED MATERIALS

- A. General: Except for items or materials indicated to be reused, salvaged, reinstalled, or otherwise indicated to remain Owner's property, remove demolished materials from Project site and legally dispose of them in an approved landfill.
 - 1. Do not allow demolished materials to accumulate on-site.
 - 2. Remove and transport debris in a manner that will prevent spillage on adjacent surfaces and areas.

3.6 SITE RESTORATION

- A. Below-Grade Areas: Rough grade below-grade areas and make ready for further excavation or new construction where appropriate. Otherwise, completely fill and compact below-grade areas and voids resulting from demolition operations with satisfactory materials according to backfill requirements in Section 02300 Earthwork for Pavements, Trails and Slope Protection.
- B. Backfilling with rubbish or burying rubbish on the site shall not be permitted.

- C. Site Grading: Uniformly rough grade area of demolished construction to a smooth surface, free from irregular surface changes. Provide a smooth transition between adjacent existing grades and new grades.

3.7 REPAIRS

- A. Promptly repair damage to items to remain, items to be removed and reinstalled, and items to be salvaged.

3.8 CLEANING

- A. Clean the drop structure face of debris at completion of work.
- B. Return adjacent areas to condition existing before demolition operations began.

3.9 DEMOLITION SCHEDULE

- A. Existing Items to Be Removed:
 - 1. Concrete box fountains and piping, as indicated in plans, in Ponds 1 and 3.
 - 2. Sidewalk damaged during construction.
 - 3. Trees as indicated in plans.
- B. Existing Items to Be Removed and Salvaged:
 - 1. Submersible fountain pumps.
 - 2. Lights and electrical wiring for concrete box fountains.
- C. Existing Items to Be Removed and Reinstalled (to be completed by Owner):
 - 1. Floating fountains in Ponds 1 and 3.
 - 2. Irrigation services.
- D. Existing Items to Remain:
 - 1. Intake and discharge structures, pump stations, floating fountain pumps, valve vaults, and piping per plans.
 - 2. Gabions and landscape boulders.

END OF SECTION

SECTION 01742

SEDIMENT DISPOSAL

PART 1 - GENERAL

1.1 RELATED DOCUMENTS

- A. Drawings and general provisions of the Contract, including General and Supplementary Conditions apply to this Section.

1.2 SUMMARY

- A. This Section includes the disposal of sediment and contaminated water, which if discharged back into the creek, would cause or contribute to an exceedance of applicable water quality standards.
- B. Related Sections include the following:
 - 1. Section 01330 – Submittal Procedures
 - 2. Section 02240 – Unwatering
 - 3. Section 02241 – Bypass Pumping
 - 4. Section 02242 – Dewatering

1.3 PERFORMANCE REQUIREMENTS

- A. The Contractor shall comply with all applicable federal, state, and local laws, regulations, permit conditions, and notification requirements.
- B. The Contractor must meet all noise restrictions.
- C. The sediment shall meet the approved disposal facility requirements.
- D. Return Water Quality Requirements: The disposal operations may result in the release of return water from the dewatering operation (if allowed), with a maximum of 100 mg/L Total Suspended Solids (TSS). The approved Testing Laboratory shall test the return water at these locations a minimum of once per day during sediment disposal operations.

If polymers are used in the dewatering operation then by product water must be disposed of in a similar method as the sediment disposal method.

The Town reserves the right to access the operational sites as needed to obtain its own samples for testing. In no way does Town sampling and testing relieve the Contractor of the required testing. In case of conflicting testing results between the Contractor's lab and the Town's, the Town's results shall govern.

- E. Dredged Material Testing Requirements:
 - 1. The Contractor shall conduct dredged material testing, as described in this section, in order to verify that dredged material is suitable for unrestricted beneficial reuse.

2. The contractor shall collect one sample of dredged material per every 1,000 cubic yards of pond sediment dredged. Samples shall be collected from the dewatered sludge.
3. Samples shall be analyzed for the following chemicals of concern (COCs) by the appropriate SW-846 method that meets Texas Risk Reduction Program (TRRP) data quality requirements:
 - a. Priority pollutant metals
 1. Antimony
 2. Arsenic
 3. Beryllium
 4. Cadmium
 5. Chromium
 6. Copper
 7. Lead
 8. Nickel
 9. Selenium
 10. Silver
 11. Thallium
 12. Zinc
 13. Mercury
 - b. Chlorinated Herbicides
 - c. Organochlorine Pesticides
4. Samples shall be collected in accordance with standard professional practice for environmental sampling using containers provided by the laboratory in a manner that prevents cross-contamination of samples.
5. Samples shall be analyzed by a NELAC – accredited environmental laboratory acceptable to the Town.
6. Samples results shall be compared to protective concentration limits (PCLs) and Texas-specific background concentrations established under the TRRP (Title 30, chapter 350 of the Texas Administrative Code) for residential land use.
7. If any COCs exceed their groundwater protection PCL and their Texas-specific background concentration (applies to metal only), the Contractor shall immediately notify the city and conduct additional analysis for that COC by the Synthetic Precipitation Leaching Procedure (SPLP). SPLP results shall be compared to PCLs for ground water ingestion. The Contractor shall immediately notify the Town of results from SPLP testing.
8. The Contractor shall provide copies of all laboratory analytical results to the Town for record files within 7 days of the date the Contractor receives those results from the laboratory.

1.4 SUBMITTALS

- A. Disposal Site: The Contractor shall submit the following for Town disposal site approval:
 1. Location and distance from the construction site.
 2. Truck route from the construction site to the disposal site. The Contractor shall meet all applicable highway transport requirements.
 3. A copy a current permit.
 4. A copy of disposal facility requirements (i.e. water content, etc.)
- B. The Contractor shall provide disposal tickets indicating that all removed dredged material was taken to the approved disposal facility.

- C. The Contractor shall submit for Town approval all alternative or additional construction access road locations.
- D. The Contractor shall submit a tabbed binder with all test results for water quality testing and dredged material testing.

PART 2 - PRODUCTS

2.1 EQUIPMENT

- A. Equipment and materials used for transporting water and sediment from the dewatering facilities to disposal shall be approved by the Town. The equipment and materials shall be leak free and monitored on a regular basis.
- B. The sediment shall be transported to the disposal site using sealed or lined tandem trucks. The Contractor is responsible for the remediation of any spillage during transit.
- C. An excavator or similar equipment may be used to transfer the sediment from the dewatering area to the trucks.

PART 3 - EXECUTION

3.1 PREPARATION

- A. Protect structures, utilities, sidetrails, pavements, and other facilities from damage caused by disposal operations.

3.2 PROTECTION

- A. Keep area free of trash and debris.
- B. In case of a spill emergency, the Contractor must notify the Town immediately and take immediate steps to mitigate the contamination. All mitigation techniques must meet all federal and state requirements.
- C. The trucks transporting sediment to the disposal facility must enter and exit the construction site on a temporary construction access road shown on the plans. The Contractor shall submit for the Town's approval all alternative or additional locations for temporary construction access roads.

3.3 TRANSPORTATION OF SEDIMENT TO THE DISPOSAL SITE

- A. Once the sediment has been dewatered to meet the approved disposal facility requirements, the material shall be stockpiled and loaded on trucks in a designated loading area and hauled to the approved disposal facility. When leaving the Construction site, the trucks shall exit through a wash rack and stabilized construction entrance.
- B. The truck drivers shall drive the approved route to the disposal site. If construction or other incident bars the truck route, the Contractor shall contact the Town immediately.

- C. The Contractor shall assume responsibility for the remediation of any spillage during transit to the disposal facility.

END OF SECTION

SECTION 02212

EMBANKMENT AND EARTHWORK FOR STRUCTURES

PART 1 - GENERAL

1.1 RELATED DOCUMENTS

- A. Drawings and general provisions of the Contract, including General and Supplementary Conditions apply to this Section.

1.2 SUMMARY

- A. This Section includes the following
 1. Material and placement requirements for embankment and wall backfills
- B. Related Sections include the following:
 1. Section 01400 - Quality Control
 2. Section 01710 - Site Clearing and Adjusting
 3. Section 02231 - Tree Protection
 4. Section 02300 - Earthwork for Pavements, Trails and Slope Protection
 5. Section 02240 - Unwatering

1.3 REFERENCED STANDARDS

- A. American Society for Testing and Materials (ASTM).
 1. D 422 - Particle Size Analysis.
 2. D 698 - Moisture-Density Relations of Soils.
 3. D 1556 - Density of Soil in Place by the Sand-Cone Method.
 4. D 2167 - Density and Unit Weight of Soil in Place by the Rubber-Balloon Method.
 5. D 2487 - Standard Practice for Classification of Soils
 6. D 2922 - Density of Soil and Soil-Aggregate in Place by Nuclear Methods (Shallow Depth).
 7. D 3017 - Moisture Content of Soil and Soil-Aggregate in Place by Nuclear Methods.
 8. D 3740 - Standard Practice for Minimum Requirements for Agencies Engaged in the Testing and/or Inspection of Soil and Rock
 9. D 4253 - Test Methods for Maximum Index Density of Soils Using a Vibratory Table.
 10. D 4254 - Test Methods for Minimum Index Density of Soils and Calculation of Relative Density.
 11. D 4318 - Liquid Limit, Plastic Limit, and Plasticity Index of Soils.
 12. E 329 - Standard Spec for Agencies Engaged in Construction Inspection and/or Testing
- B. TxDOT Departmental Material Specifications, 6000 Series

1.4 SUBMITTALS

- A. Product Data: For the following:

1. Geotextile.

- B. Samples: 12-by-12-inch Sample of subdrainage and separation geotextiles.
- C. Field Test Reports: Refer to Section 01400.

1.5 QUALITY ASSURANCE

- A. Geotechnical Testing Agency Qualifications: An Owner engaged testing agency qualified according to ASTM E 329 to conduct soil materials and rock-definition testing, as documented according to ASTM D 3740 and ASTM E 548.
- B. Preexcavation Conference: Conduct conference at Project site.

PART 2 - PRODUCTS

2.1 EQUIPMENT

- A. The Contractor may use any excavating and hauling equipment adaptable to the work and any method generally accepted for this type of work. No equipment shall be allowed outside the areas indicated on the drawings.
- B. Compaction equipment weighing 2,000 lbs or less shall be used within 5 feet of new walls.
- C. Contractor must have sufficient size, type, and quantity of equipment to complete project in allotted time.

2.2 CLAY FILL

- A. Satisfactory Materials: Suitability of clay fill materials is subject to the Engineer's approval. The fill shall be free of rocks debris, sludge, vegetation, and roots or limbs larger than 0.5 inches in diameter.
- B. Source. Clay fill shall be from an approved source and be limited to CH and CL materials free from organics with a minimum liquid limit of 40 and minimum plasticity index of 20.
- C. Quality. Fill materials used for backfill must be free of excessive silts and sandy soils. At least 50% should pass a No. 200 sieve. Do not use soil containing brush, roots, sod or similar perishable material.

2.3 GRANULAR FILL

- A. Satisfactory Materials: Suitability of granular fill materials is subject to the Engineer's approval. The fill shall be free draining aggregate meeting the requirements of NCTCOG Item 303.2.1.3 (Coarse concrete aggregate, Ref. 5).
- B. Source. Granular materials for wall backfill shall be free-draining washed river sand and gravel

or crushed stone from an approved off-site source.

- C. Quality. Granular fill materials shall be free of clay soils. No more than 5% of the material shall pass a No. 200 sieve, and the maximum particle size shall be 1.5 inches. Do not use soil containing brush, roots, sod or similar perishable material.

2.4 GEOTEXTILE

- A. Filter Fabric shall meet the requirements of the TxDOT Departmental Material Specifications Item DMS-6200 "Filter Fabric" Type 1.

PART 3 - EXECUTION

3.1 SOIL MANAGEMENT PLAN

- A. Prior to initiation of any earthwork activity, the Contractor shall develop a soil management plan. The soil management plan shall identify the on-site areas which shall be used for:
 1. Embankment
 2. Impervious backfill for retaining walls designed for undrained conditions
 3. Topsoil
 4. Common fill and backfill

The plan shall identify the quantity of material available and shall establish a procedure for handling and stockpiling the material. The plan shall be submitted to the Engineer for review.

- B. The testing laboratory, retained by the Owner, shall assist the Contractor by collecting bulk samples and performing tests necessary to identify various materials. See Section 3.8 of this Specification.
- C. The Contractor shall handle, stockpile and manage the soils in a manner which assures that all required materials are retained on-site throughout the construction process. The Owner shall not pay for any additional handling, stockpiling or retrieval of materials which have been stockpiled.

3.2 PREPARATION

- A. Protect the embankment, structures, utilities, sidewalks, pavements, and other facilities from damage caused by settlement, lateral movement, undermining, washout, and other hazards created by earthwork operations.
- B. Preparation of subgrade for earthwork operations including removal of vegetation, topsoil, debris, obstructions, and deleterious materials from ground surface is specified in Section 01710 Site Clearing and Adjusting.
- C. Protect and maintain erosion and sedimentation controls during earthwork operations in accordance with the Contractor's Stormwater Pollution Prevention Plan. (SWPPP).

- D. Provide protective insulating materials to protect subgrades and foundation soils against freezing temperatures or frost.

3.3 UNWATERING AND DEWATERING

- A. Refer to Section 02240 for Unwatering Requirements and 02242 for Dewatering Requirements.

3.4 EXPLOSIVES

- A. Explosives: Do not use explosives.

3.5 EXCAVATION, GENERAL

- A. Unclassified Excavation: Excavated materials may include rock, soil materials, brush, and obstructions. No changes in the Contract Sum or the Contract Time will be authorized for rock excavation or removal of obstructions.

- 1. If excavated materials intended for fill and backfill include unsatisfactory soil materials and rock, replace with satisfactory soil materials.

- B. Excavation Protection

- 1. The Contractor is responsible for maintenance of stable construction slopes for the safety of workers and the public and to protect existing improvements.
 - 2. Temporary excavations shall be in accordance with all applicable rules, regulations and practices, including OSHA regulations on Sloping and Benching, Standard 1926.
 - 3. Construction slopes and limits indicated on the Drawings represent the steepest slopes assumed to be permissible. The contractor shall evaluate the suitability of all slopes for construction safety purposes and construct flatter slopes where necessary. Notify the Engineer where flatter slopes are required.

- C. Storage of Soil Materials

- 1. Stockpile soil materials without intermixing. Place, grade, and shape stockpiles to drain surface water.
 - 2. Stockpile soil materials away from excavations and clear from drip lines of trees.

3.6 EXCAVATION FOR STRUCTURES

- 1. Not Applicable

3.7 TREATMENT OF NATURAL SUBGRADE UNDER EMBANKMENTS

- A. Prior to replacement of the embankment, the subgrade shall be prepared by removing soft or undesirable materials, including organic material, to a depth (not greater than three feet) to obtain desirable material. Break down sides of holes or depressions to flatten the slopes. Fill each depression with the appropriate soil for the materials to be placed on the subgrade. Place the fill in layers moistened and compacted as specified in this Section. Impervious fill material shall also be placed according to Part 3.11 of this Section.

- B. Prior to the placement of any soil lift, the previously compacted surface should be lightly scarified

2 inches deep or rolled with a sheepsfoot roller to enhance bonding between lifts.

- C. Immediately prior to placement of embankment, the subgrade shall be scarified to a minimum depth of 8 inches. Remove roots and debris 0.5-inches and larger turned up while loosening the soil. The scarified material shall then be recompacted to at least 95 percent of the standard Proctor maximum dry density at moisture content between -2 and +3 percent of the optimum moisture content.
- D. Take care to prepare the embankment so that planes of seepage or weakness are not induced. Should the Engineer suspect such a deficiency, the material shall be thoroughly disked and recompacted before proceeding with construction.

3.8 PLACING EMBANKMENT FILL

- A. Inspection of Subgrade. Do not place fill on any part of the embankment subgrade until the subgrade preparation has been approved by a qualified Geotechnical Engineer.
- B. Removing Debris. During the dumping and spreading process, remove all organic material larger than 0.5 inches in diameter, stones and debris that are uncovered in the embankment materials.
- C. Seepage Cutoff Wall. Construct the concrete cutoff wall replacement as indicated on the Drawings. After the wall has cured in accordance with Section 03300, remove the forms and place embankment fill on both sides of the wall evenly to prevent uneven loading. Notify the Engineer if the existing cutoff wall encountered differs substantially from what is shown on the Drawings.
- D. Spreading Fill. After dumping, spread the materials in horizontal layers over the entire fill area. The thickness of each layer before compaction must not exceed 8 inches unless otherwise directed. As soon as possible after placement begins, crown the surface to drain freely and maintain such conditions throughout construction.
- E. Attaining Proper Bond. Refer to paragraph 3.7.D.
- F. Lines and Grades. The embankment shall be constructed to the lines and grades as indicated on the cross section drawings. All embankments and fills shall be final graded to a tolerance of plus or minus one-tenth of a foot (+0.1'). There will be no payment for shrinkage or consolidation that occurs during construction. The end slopes and side slopes of fill sections shall not be steeper than those shown on the Drawings.
- G. Conduct of the Work. The Contractor shall maintain and protect the embankment in a satisfactory condition at all times until final completion and acceptance of all work under the contract. If the hauling equipment causes horizontal shears or slicken sides, rutting, quaking, heaving, cracking, or excessive deformation of the embankments, the Contractor shall limit the type, load, travel speed, and/or haul pattern of the hauling equipment on the embankment. The Contractor shall excavate and remove from the embankments any material which the Engineer considers objectionable and shall also dispose of such materials and refill the excavated area. The Contractor may be required to remove any embankment material placed outside of prescribed

lines shown on the Drawings. Any material rendered unsuitable as a result of the Contractor's operation shall be replaced by the Contractor at his own expense. Contractor shall stay within construction limits.

3.9 BACKFILL FOR WALLS

- A. Place and compact backfill in excavations promptly, but not before completing the following:
 - 1. Installation of wall drainage. Wrap perforated pipe with filter fabric as indicated on the Drawings.
 - 2. Removing concrete formwork
 - 3. Performing required surveying, testing, and inspection.
 - 4. Removing trash and debris.
 - 5. Removing temporary shoring and bracing.
 - 6. Constructing indicated cut-off walls.
 - 7. Placing filter fabric as indicated on the drawings.
- B. Place backfill on subgrades free of mud, frost, snow, or ice.
- C. Backfill and compact on both sides of cut-off walls evenly and at the same rate to prevent unbalanced lateral loading on the walls.
- D. Place a 2-foot thick compacted clay cap above granular wall backfill as indicated on the Drawings. Slope surface away from walls as shown.

3.10 MOISTURE CONTROL

- A. Adjustment: The moisture content at the time of compaction shall be within the range specified. Material that is too dry shall be moistened by sprinkling, before and during manipulation, to properly condition the material for compaction. If the material is too wet, it should be mixed with drier material or aerated until the moisture content has reduced to a satisfactory compaction range. Thorough breakdown of the onsite clay soils and mixing with water may be required to achieve optimum moisture content. Each fill lift shall be thoroughly mixed with soil until it is free of large clods.

3.11 COMPACTION

- A. Place backfill and fill soil materials in layers not more than 8 inches in loose depth for material compacted by heavy compaction equipment, and not more than 6 inches in loose depth for material compacted by hand-operated tampers.
- B. Place backfill and fill soil materials evenly on all sides of structures to required elevations, and uniformly along the full length of each structure.
- C. Compact soil materials to not less than the following percentages of maximum dry unit weight according to ASTM D 698:
 - 1. Granular Backfill: Compact granular backfill to at least 98 percent of the material's maximum dry density at a moisture content within 3% of optimum moisture content (-3 to 3 percent).

2. Clay Fill for Embankment and Wall Backfill: Compact clay fill to at least 95 percent of the material's maximum dry density at a moisture content between optimum moisture content and 5% above optimum (0 to 5 percent).
3. General Clay fill: Compact general clay fill (PI < 20) for clay cap above granular backfill and other applications indicated on the drawings to at least 95 percent of the material's maximum dry density at a moisture content within 3% of optimum moisture content (-3 to 3 percent).

3.11 EMBANKMENT PROTECTION

- A. Embankment slope protection shall be accomplished in accordance with the requirements of Section 02300 Earthwork for Pavements, Trails and Slope Protection.

3.12 MATERIAL DISPOSAL

- A. Excess Material. Remove excess excavated material and excess topsoil from the area before substantial completion. Excess material shall be hauled off-site.
- B. Waste Material. Dispose of waste material in accordance with Section 01732, "Demolition".

3.13 TESTING

- A. The specified Testing Laboratory, or Owner's Representative, will conduct the following tests throughout construction of the embankment and retaining wall backfills:
 1. Prepare optimum moisture/density relationship for subgrade.
 2. Make density tests to determine degree of compaction for subgrade, embankment, and wall backfill.
 3. Perform tests as required on materials to assure compliance with this Section.
 4. Test materials from all source(s).
 5. Compaction testing frequency shall not be less than one test per lift per 5,000 square feet. For areas where hand tamping is required, the testing frequency shall be one test per lift, per 100 linear feet of area.

3.14 SPECIAL PROJECT REQUIREMENTS

- A. Following are special project requirements for embankment fill and related project work..
 1. Contractor shall construct cofferdams as required, dewater the area and remove unsuitable materials prior to excavation of embankment.
 2. The Contractor shall conduct his operations in such a fashion that trucks and other vehicles do not create a dirt nuisance in the streets. The truck beds shall be sufficiently tight, and shall be loaded in such a manner that objectionable materials will not be spilled onto the streets. Any dirt, mud, or other materials that are spilled onto the streets or deposited onto the streets by the tires of vehicles shall be promptly cleared away by the Contractor.
 3. The Contractor shall comply with and be prepared to implement emergency planning at all times during Construction. Perform daily inspections of the project area. Take the required action for abnormal conditions or changes observed around the project site that may lead to, or be symptomatic of, problems.

END OF SECTION

SECTION 02231

TREE PROTECTION

PART 1 GENERAL

1.1 RELATED DOCUMENTS

- A. Drawings and general provisions of the Contract, including General and Supplementary Conditions and Division 1 Specification Sections, apply to this Section.

1.2 SUMMARY

- A. This Section includes the protection and trimming of existing trees that interfere with, or are affected by, execution of the Work, whether temporary or permanent construction.
- B. Related Sections include the following:
 - 1. Section 01710 - Site Clearing and Adjusting
 - 2. Section 02300 - Earthwork for Pavements, Trails and Slope Protection
 - 3. Section 32 93 00 - Landscape Planting

1.3 DEFINITIONS

- A. Tree Protection Zone: Area surrounding individual trees or groups of trees to remain during construction, and defined by the drip line of individual trees or the perimeter drip line of groups of trees, unless otherwise indicated.

1.4 SUBMITTALS

- A. Product Data: For each type of product indicated.
- B. Tree Pruning Schedule: Written schedule from arborist detailing scope and extent of pruning of trees to remain that interfere with or are affected by construction.
- C. Qualification Data: For tree service firm and arborist.
- D. Certification: From arborist, certifying that trees indicated to remain have been protected during construction according to recognized standards and that trees were promptly and properly treated and repaired when damaged.
- E. Maintenance Recommendations: From arborist, for care and protection of trees affected by construction during and after completing the Work.

1.5 QUALITY ASSURANCE

- A. Tree Service Firm Qualifications: An experienced tree service firm that has successfully completed tree protection and trimming work similar to that required for this Project and that will assign an experienced, qualified arborist to Project site during execution of tree protection and trimming.

- B. Arborist Qualifications: An arborist certified by ISA or licensed in the jurisdiction where Project is located.
- C. Tree Pruning Standard: Comply with ANSI A300 (Part 1), "Tree, Shrub, and Other Woody Plant Maintenance--Standard Practices (Pruning)."
 - 1. Before tree protection and trimming operations begin, meet with representatives of authorities having jurisdiction, Owner, Landscape Architect, consultants, and other concerned entities to review tree protection and trimming procedures and responsibilities.

PART 2 PRODUCTS

2.1 MATERIALS

- A. Drainage Fill: Selected crushed stone, or crushed or uncrushed gravel, washed, ASTM D 448, Size 24, with 90 to 100 percent passing a 2-1/2-inch sieve and not more than 10 percent passing a 3/4-inch sieve.
- B. Topsoil: Natural or cultivated surface-soil layer containing organic matter and sand, silt, and clay particles; friable, pervious, and black or a darker shade of brown, gray, or red than underlying subsoil; reasonably free of subsoil, clay lumps, gravel, and other objects more than 1 inch in diameter; and free of weeds, roots, and toxic and other nonsoil materials.
 - 1. Obtain topsoil only from well-drained sites where topsoil is 4 inches deep or more; do not obtain from bogs or marshes.
- C. Filter Fabric: Manufacturer's standard, nonwoven, pervious, geotextile fabric of polypropylene, nylon, or polyester fibers.
- D. Chain-Link Fence: Metallic-coated steel chain-link fence fabric of 0.120-inch-diameter wire; a minimum of 48 inches high; with 1.9-inch-diameter line posts; 2-3/8-inch-diameter terminal and corner posts; 1-5/8-inch-diameter top rail; and 0.177-inch-diameter bottom tension wire; with tie wires, hog ring ties, and other accessories for a complete fence system.
- E. Organic Mulch: Shredded hardwood, free of deleterious materials.

PART 3 EXECUTION

3.1 PREPARATION

- A. Temporary Fencing: Install temporary fencing around tree protection zones to protect remaining trees and vegetation from construction damage. Maintain temporary fence and remove when construction is complete.
 - 1. Install chain-link fence according to ASTM F 567 and manufacturer's written instructions.
- B. Protect tree root systems from damage caused by runoff or spillage of noxious materials while mixing, placing, or storing construction materials. Protect root systems from ponding, eroding, or excessive wetting caused by dewatering operations.
- C. Mulch areas within drip line of trees to remain and other areas indicated.

1. Apply 2-inch average thickness of organic mulch. Do not place mulch within 6 inches of tree trunks.
 - D. Do not store construction materials, debris, or excavated material inside tree protection zones. Do not permit vehicles or foot traffic within tree protection zones; prevent soil compaction over root systems.
 - E. Maintain tree protection zones free of weeds and trash.
 - F. Do not allow fires within tree protection zones.
- 3.2 EXCAVATION
- A. Install shoring or other protective support systems to minimize sloping or benching of excavations.
 - B. Do not excavate within tree protection zones, unless otherwise indicated.
 - C. Where excavation for new construction is required within tree protection zones, hand clear and excavate to minimize damage to root systems. Use narrow-tine spading forks and comb soil to expose roots.
 1. Redirect roots in backfill areas where possible. If encountering large, main lateral roots, expose roots beyond excavation limits as required to bend and redirect them without breaking. If encountered immediately adjacent to location of new construction and redirection is not practical, cut roots approximately 3 inches back from new construction.
 2. Do not allow exposed roots to dry out before placing permanent backfill. Provide temporary earth cover or pack with peat moss and wrap with burlap. Water and maintain in a moist condition. Temporarily support and protect roots from damage until they are permanently relocated and covered with soil.
 - D. Where utility trenches are required within tree protection zones, tunnel under or around roots by drilling, auger boring, pipe jacking, or digging by hand.
 1. Root Pruning: Do not cut main lateral roots or taproots; cut only smaller roots that interfere with installation of utilities. Cut roots with sharp pruning instruments; do not break or chop.
- 3.3 REGRADING
- A. Grade Lowering: Where new finish grade is indicated below existing grade around trees, slope grade beyond tree protection zones. Maintain existing grades within tree protection zones.
 - B. Grade Lowering: Where new finish grade is indicated below existing grade around trees, slope grade away from trees as recommended by arborist, unless otherwise indicated.
 1. Root Pruning: Prune tree roots exposed during grade lowering. Do not cut main lateral roots or taproots; cut only smaller roots. Cut roots with sharp pruning instruments; do not break or chop.
 - C. Minor Fill: Where existing grade is 6 inches or less below elevation of finish grade, fill with topsoil. Place topsoil in a single uncompacted layer and hand grade to required finish elevations.

- D. Moderate Fill: Where existing grade is more than 6 inches but less than 12 inches below elevation of finish grade, place drainage fill, filter fabric, and topsoil on existing grade as follows:
 - 1. Carefully place drainage fill against tree trunk approximately 2 inches above elevation of finish grade and extend not less than 18 inches from tree trunk on all sides. For balance of area within drip-line perimeter, place drainage fill up to 6 inches below elevation of grade.
 - 2. Place filter fabric with edges overlapping 6 inches minimum.
 - 3. Place fill layer of topsoil to finish grade. Do not compact drainage fill or topsoil. Hand grade to required finish elevations.

3.4 TREE PRUNING

- A. Prune trees to remain that are affected by temporary and permanent construction.
- B. Prune trees to remain to compensate for root loss caused by damaging or cutting root system. Provide subsequent maintenance during Contract period as recommended by arborist.
- C. Pruning Standards: Prune trees according to ANSI A300 (Part 1) as follows:
 - 1. Type of Pruning: Cleaning.
 - 2. Specialty Pruning: Restoration.
- D. Cut branches with sharp pruning instruments; do not break or chop.
- E. Chip removed tree branches and remove offsite.

3.5 TREE REPAIR AND REPLACEMENT

- A. Promptly repair trees damaged by construction operations within 24 hours. Treat damaged trunks, limbs, and roots according to arborist's written instructions.
- B. Remove and replace trees indicated to remain that die or are damaged during construction operations that arborist determines are incapable of restoring to normal growth pattern.
 - 1. Provide new trees of same size and species as those being replaced.
 - 2. Provide new trees of 6-inch caliper size and of a species selected by Architect when damaged trees more than 6 inches in caliper size, measured 12 inches above grade, are required to be replaced. Plant and maintain new trees as specified in Section 32 93 00 Landscape Planting.
- C. Aerate surface soil, compacted during construction, 10 feet beyond drip line and no closer than 36 inches to tree trunk. Drill 2-inch-diameter holes a minimum of 12 inches deep at 24 inches o.c. Backfill holes with an equal mix of augered soil and sand.

3.6 DISPOSAL OF WASTE MATERIALS

- A. Burning is not permitted.
- B. Disposal: Remove excess excavated material and displaced trees from Owner's property.

END OF SECTION

SECTION 02240

UNWATERING

PART 1 GENERAL

1.1 RELATED DOCUMENTS

- A. Drawings and general provisions of the Contract, including General and Supplementary Conditions and Specification Sections, apply to this Section.

1.2 SUMMARY

- A. Definition: the act of draining rainwater, pond water, and/or groundwater from ponds, building foundations, vaults, and trenches.
- B. Section includes construction unwatering, including care of water during construction, removal of water from foundations, and barriers (i.e. cofferdams, dikes, and berms).
- C. Related Sections include the following:
 - 1. Section 02241 – Bypass Pumping
 - 2. Section 02242 – Dewatering
 - 3. Section 02243 – Aquatic Species Recovery and Relocation

1.3 PERFORMANCE REQUIREMENTS

- A. Provide unwatering and protective works to allow excavation and construction to proceed on dry, stable subgrades. Design, furnish, install, test, operate, monitor, and maintain unwatering system of sufficient scope, size, and capacity to control hydrostatic pressures and to lower, control, remove, and dispose of ground and surface water. Design, furnish, install, monitor, and maintain barriers, channels, flumes, drains, sumps, and/or other temporary diversion and protective works.
 - 1. Delegated Design: Design unwatering system and protective works. The design shall be performed and sealed by a professional engineer licensed in the state of Texas for review.
 - 2. The Contractor's plan for the care of water during construction shall be subject to review by the Engineer. The plan may be placed in operation upon notification of the Engineer, but nothing in this section shall relieve the contractor from full responsibility for the adequacy of the unwatering and protection works.
 - 3. Prior to unwatering, the Contractor shall coordinate the unwatering process with Halff Associates, Inc. (Halff) for the recovery and relocation of aquatic species. Refer to Section 02243, "Aquatic Species Recovery and Relocation".
 - 4. Dimensions of barriers shall provide sufficient clearance for the construction, inspection, and removal of required forms, and if necessary, sufficient room to allow pumping outside the forms.
 - 5. Continuously monitor and maintain unwatering operations to ensure erosion control, stability of excavations and constructed slopes, that excavation does not flood, and that damage to subgrades and permanent structures is prevented.

6. Prevent surface water and ground water from entering excavations and from ponding on prepared subgrades.
7. Protect subgrades from softening, undermining, washout, and damage by rain or water accumulation. Reroute surface water runoff away from excavated areas. Do not allow water to accumulate in excavations.
8. Accomplish unwatering without damaging existing structures, dam embankment, and any other site improvements adjacent to excavation. The contractor shall be responsible for and shall repair at his expense any damage to the foundations, structures, dam embankment, site improvements, or any other part of the work caused by floods, water, or failure of any part of the unwatering system or the protective works.
9. Remove unwatering system when no longer required for construction. All cofferdams, temporary grading, dikes, berms, and other protective works shall be completely removed from the lake and channel after construction completion.

1.4 SUBMITTALS

A. Experience List

1. Provide a list of barrier designs performed by the Contractor's Engineer and a list of barrier installations performed by the Contractor, each meeting the minimum experience requirements in Part 1.5 of this Section. Each experience list shall include:
 - a. Name of project and dates of construction
 - b. Names and contact information for Owner and Consultant Engineer
 - c. Barrier type (i.e. sheet pile, earth fill, etc.), height, length, total material (square feet, cubic yards, etc.)
 - d. Type of water body (river, lake, etc.) and nature of construction protected by barriers.

B. Care of Water Plan: Include a written plan for unwatering operations. The plan shall include:

1. Proposed means to protect work areas from water, including types and locations of barriers.
2. Proposed means for unwatering.
3. Estimated sequence of work and construction schedule indicating order, start time, and duration of each individual work item involving unwatering, diversion, or protection. Include in the schedule the installation and removal of diversion, protection and unwatering systems for each individual work item.
4. Operation, testing, maintenance and monitoring steps that the Contractor will implement while the unwatering and protection works are in use. Include schedule showing the frequency that each item will be inspected, tested, and maintained. Include a sample inspection log.
5. Control procedures to be adopted if unwatering problems arise.

C. Shop Drawings: For unwatering system and protection works.

1. The submittal must show arrangement, locations, and details sump pumps, size of pumps, quantity of pumps, wells and well points; locations of risers, headers, filters, pumps, power units, and discharge lines; and means of discharge, control of sediment, and disposal of water.
2. Piezometers and flow-measuring devices for monitoring performance of unwatering system are not required.
3. Show site plan, grading plan with existing and proposed temporary contours, sections, and details of protective works.

- D. Delegated-Design Submittal: For unwatering systems, cofferdams and other protective works provided to comply with performance requirements and design criteria, including analysis data, design calculations, and details of structural members, signed and sealed by the licensed professional engineer responsible for their preparation.
- E. Field quality-control reports.
- F. Other Informational Submittals:
 - 1. Photographs: Show existing conditions of adjoining construction and site improvements that might be misconstrued as damage caused by unwatering operations.

1.5 QUALITY ASSURANCE

- A. Regulatory Requirements: Comply with governing TCEQ and EPA notification regulations before beginning unwatering. Comply with hauling and disposal regulations of authorities having jurisdiction. Comply with applicable OSHA requirements for barriers (cofferdams, dikes, berms, etc.) and protective works.
- B. Experience
 - 1. The Contractor's Engineer shall have designed a minimum of three (3) barriers of the type(s) proposed.
 - 2. The Contractor shall have installed a minimum of three (3) barriers of the type(s) proposed.
- C. Pre-installation Conference: Conduct conference at Project site with Owner, Construction Manager, and Engineer.
 - 1. Review methods and procedures related to unwatering including, but not limited to, the following:
 - a. Inspection and discussion of condition of site to be unwatered including coordination with temporary erosion control measures and temporary controls and protections.
 - b. Proposed site clearing and excavations.
 - c. Existing utilities and subsurface conditions.
 - d. Coordination for interruption, shutoff, capping, and continuation of utility services.
 - e. Construction schedule. Verify availability of Installer's personnel, equipment, and facilities needed to make progress and avoid delays.
 - f. Testing and monitoring of unwatering system.
 - g. Contractor's control procedures for potential problems.

1.6 PROJECT CONDITIONS

- A. Interruption of Existing Utilities: Do not interrupt any utility serving facilities occupied by Owner or others unless permitted under the following conditions:
 - 1. Notify Construction Inspector no fewer than two days in advance of proposed interruption of utility.
 - 2. Do not proceed with interruption of utility without utility's written permission.
 - 3. The floating fountains and irrigation systems will be placed out of service by the Owner prior to construction.

- B. Project-Site Information: No geotechnical reports have been prepared for this Project. Owner will not be responsible for interpretations or conclusions drawn from outside geotechnical explorations.
 - 1. Make additional test borings and conduct other exploratory operations necessary for unwatering and design and installation of protective works.
- C. Survey Work: Engage a registered professional land surveyor or professional engineer to survey adjacent existing buildings, structures, and site improvements, establishing exact elevations at fixed points to act as benchmarks. Clearly identify benchmarks and record existing elevations.
 - 1. During unwatering, regularly resurvey benchmarks, maintaining an accurate log of surveyed elevations for comparison with original elevations. Promptly notify Owner if changes in elevations occur or if cracks, sags, or other damage is evident in adjacent construction.

PART 2 PRODUCTS

2.1 BARRIERS

- A. The type of barrier (cofferdam, dike, berm, etc.) implemented is at the Contractor's discretion. The actual barrier design shall be submitted for Engineer's review as required in Part 1.4. The barrier shall be removed upon completion of work.

2.2 UNWATERING EQUIPMENT

- A. Pumps used for unwatering shall include means for noise attenuation on the pump motors.

PART 3 EXECUTION

3.1 PREPARATION

- A. Protect structures, utilities, sidewalks, pavements, and other facilities from damage caused by settlement, lateral movement, undermining, washout, and other hazards created by unwatering operations.
 - 1. Protect subgrades and foundation soils from softening and damage by rain or water accumulation.
- B. Install unwatering system to ensure minimum interference with roads, streets, walks, and other adjacent occupied and used facilities.
 - 1. Do not close or obstruct streets, walks, or other adjacent occupied or used facilities without permission from Owner and authorities having jurisdiction. Provide alternate routes around closed or obstructed traffic ways if required by authorities having jurisdiction.
- C. Provide temporary grading within project limits to facilitate unwatering and control of surface water.
- D. Monitor unwatering systems continuously.

1. Locate and secure pumps and other unwatering equipment to reduce the potential of tampering or vandalism. Inspect equipment regularly and repair damage promptly.
- E. Promptly repair damages to adjacent facilities caused by unwatering.
- F. Protect and maintain temporary erosion and sedimentation controls during unwatering operations.

1.7 INSTALLATION

- A. Install unwatering system utilizing sumps, sump pumps, wells, well points, or similar methods complete with pump equipment, standby power and pumps, filter material gradation, valves, appurtenances, water disposal, and surface-water controls.
 1. Space well points or wells at intervals required to provide sufficient unwatering.
 2. Use filters or other means to prevent pumping of fine sands or silts from the subsurface.
- B. Before excavating below ground-water level, place system into operation to lower water to required levels. Operate system continuously until dredging, desilting, and demolition have been completed and fill materials have been placed or until unwatering is no longer required.
- C. Provide an adequate system to lower and control surface and ground water to permit excavation, construction of structures, and placement of fill materials on dry subgrades. Install sufficient unwatering equipment to drain water-bearing strata above and below bottom of foundations, drains, sewers, and other excavations.
 1. Do not permit open-sump pumping that leads to loss of fines, soil piping, subgrade softening, and slope instability.
- D. Reduce hydrostatic head in water-bearing strata below subgrade elevations of foundations, drains, sewers, and other excavations.
- E. Dispose of water removed by unwatering in a manner that avoids endangering public health, property, and portions of work under construction or completed. Dispose of water and sediment in a manner that avoids inconvenience to others. Provide sumps, sedimentation tanks, and other flow-control devices as required by authorities having jurisdiction.
- F. Provide standby equipment on site, installed and available for immediate operation, to maintain unwatering on continuous basis if any part of system becomes inadequate or fails. If unwatering requirements are not satisfied due to inadequacy or failure of unwatering system, restore damaged structures and foundation soils at no additional expense to Owner.
 1. Remove unwatering system from Project site on completion of unwatering.
 2. Remove protective works from Project site completely upon completion of work.
- G. Damages: Promptly repair damages to adjacent facilities caused by unwatering operations.

1.8 FIELD QUALITY CONTROL

- A. Observation Wells: Provide, take measurements, and maintain the observation wells; additional observation wells may be required by authorities having jurisdiction.
 1. Repair or replace, within 24 hours, observation wells that become inactive, damaged, or destroyed. In areas where observation wells are not functioning properly, suspend construction activities until reliable observations can be made. Add or remove water

from observation-well risers to demonstrate that observation wells are functioning properly.

- B. Provide continual observation to ensure that subsurface soils are not being removed by the unwatering operation.

END OF SECTION

SECTION 02241
BYPASS PUMPING

PART 1 GENERAL

1.1 RELATED DOCUMENTS

- A. Drawings and general provisions of the Contract, including General and Supplementary Conditions and Specification Sections, apply to this Section.

1.2 SUMMARY

- A. Uncontaminated water shall be bypassed around a pond while the pond is unwatered and in the process of unwatering and returned to the main stream.
- B. Related Sections include the following:
 - 1. Section 02240 – Unwatering
 - 2. Section 02242 – Dewatering

1.3 PERFORMANCE REQUIREMENTS

- A. This work consists of furnishing all labor material and equipment necessary to bypass the flow of water around the designated ponds.
- B. The Contractor shall conduct flow control operations with extreme care at all times to maintain normal downstream and upstream flows and minimize flooding.
- C. The process shall not disturb upstream sediment. An impoundment may be temporarily constructed around the pump, if needed.
- D. Only water that does not cause or contribute to an exceedance of applicable water quality standards is permitted to return to the natural system. All contaminated and unfiltered water must be disposed of properly per Corps of Engineers, EPA, TCEQ and Town of Addison standards.

1.4 SUBMITTALS

- A. Diversion Plan: Include a written plan for diversion operations. The plan shall include:
 - 1. Proposed means to protect work areas from water, including types and locations of barriers and diversion structures.
 - 2. Primary pump curves and hydraulic calculations.
 - 3. Size, quantity, and location of pumps.
 - 4. Estimated sequence of work and construction schedule indicating order, start time, and duration of each individual work item involving diversion. Include in the schedule the installation and removal of diversion for each individual work item.
 - 5. Operation, testing, maintenance and monitoring steps that the Contractor will implement while the unwatering and diversion and protection works are in use. Include schedule

showing the frequency that each item will be inspected, tested, and maintained. Include a sample inspection log.

6. Control procedures to be adopted if unwatering problems arise.

The plan shall conform to Corps of Engineers, Environmental Protection Agency (EPA) and Texas Commission on Environmental Quality (TCEQ) regulations. In case of conflict, the most stringent shall apply.

B. Shop Drawings:

1. Submittal must show arrangement, locations, and details of bypass pumps, wells and well points; locations of risers, headers, filters, pumps, power units, and discharge lines; and means of discharge, control of sediment, and disposal of water.

C. Field quality-control reports.

D. Other Informational Submittals:

1. Photographs: Show existing conditions of adjoining construction and site improvements that might be misconstrued as damage caused by bypass pumping operations.

1.5 QUALITY ASSURANCE

A. Pre-installation Conference: Conduct conference at Project site with Owner, Construction Manager, and Engineer.

1. Review methods and procedures related to bypass pumping including, but not limited to, the following:
 - a. Temporary erosion control measures and temporary controls and protections.
 - b. Existing utilities and subsurface conditions.
 - c. Coordination for interruption, shutoff, capping, and continuation of utility services.
 - d. Construction schedule. Verify availability of Installer's personnel, equipment, and facilities needed to make progress and avoid delays.
 - e. Testing and monitoring of bypass system.
 - f. Contractor's control procedures for potential problems.

PART 2 PRODUCTS

2.1 BYPASS PUMPS AND EQUIPMENT

- A. Pumps used for bypass shall include means for noise attenuation on the pump motors.

PART 3 EXECUTION

3.1 PREPARATION

- A. Promptly repair damages to adjacent facilities caused by bypass pumping.
- B. Protect and maintain temporary and permanent erosion and sedimentation controls during bypass pumping operations.

3.2 INSTALLATION

- A. Install bypass pumping system complete with pump equipment, standby power and pumps, filter material gradation, valves, appurtenances, and surface-water controls.
 - 1. Use filters or other means to prevent pumping of fine sands or silts from the subsurface.
- B. Provide standby equipment on site, installed and available for immediate operation, to maintain bypass pumping on continuous basis if any part of system becomes inadequate or fails. If bypass requirements are not satisfied due to inadequacy or failure of unwatering system, restore damaged structures and foundation soils at no additional expense to Owner.
 - 1. Remove bypass system from Project site on completion of desilting.
 - 2. Remove diversion structures and protective works from Project site completely upon completion of work.
- C. Damages: Promptly repair damages to adjacent facilities caused by bypass operations.

3.3 FIELD QUALITY CONTROL

- A. Provide continual observation to ensure that subsurface soils are not being removed by the bypass operation.

END OF SECTION

SECTION 02242

DEWATERING

PART 1 - GENERAL

1.1 RELATED DOCUMENTS

- A. Drawings and general provisions of the Contract, including General and Supplementary Conditions apply to this Section.

1.2 SUMMARY

- A. This Section includes the removal of water from sediment and soils.
- B. Related Sections include the following:
 - A. Section 02240 – Unwatering
 - B. Section 02241 – Bypass Pumping
 - C. Section 02300 – Earthwork for Pavements, Trails and Slope Protection
- C. Dewatering operations shall take place within a staging area approved by the Town.

1.3 PERFORMANCE REQUIREMENTS

- A. The Contractor shall comply with all applicable federal, state, and local laws, regulations, permit conditions, and notification requirements.
- B. The Contractor must meet all noise restrictions.
- C. The sediment shall be dewatered to meet the approved disposal facility requirements.

1.4 SUBMITTALS

- A. Dewatering Plan: Include a written plan for dewatering operations. The plan shall include:
 - A. Proposed means for dewatering.
 - B. Emulsion plan.
 - C. Proposed location and area where the dewatering process will occur.
 - D. Equipment to be used, flocculants, admixtures, sequencing, and effluent and pumping operation of return flows and loading operations for transport of final design.
 - E. Proposed means to protect surrounding area.
 - F. Estimated sequence of work and schedule indicating order, start time, and duration of each individual work item involving dewatering.
 - G. Operation, testing, maintenance and monitoring steps that the Contractor will implement while the dewatering and protection works are in use. Include schedule showing the frequency that each item will be inspected, tested, and maintained. Include a sample inspection log.
 - H. Disposal plan for byproduct water of dewatering operation.

1.5 PROJECT CONDITIONS

- A. Existing Utilities: Do not interrupt utilities serving facilities occupied by Owner or others unless permitted in writing by Engineer and then only after arranging to provide temporary utility services according to requirements indicated.
 - A. Notify Engineer not less than two days in advance of proposed utility interruptions.
 - B. Do not proceed with utility interruptions without Engineer's written permission.

PART 2 - PRODUCTS

2.1 EQUIPMENT

- A. The Contractor shall choose the type of dewatering equipment relevant for the proposed method of dewatering. Belt presses, cyclones, geobags and similar equipment are acceptable.
- B. The Contractor shall own his own belt press and associated dewatering equipment used on this project.
- C. Equipment and materials used for transporting water and sediment from the pond to the dewatering facilities and from the dewatering facilities to disposal shall be approved by the Town. The equipment and materials shall be leak free and monitored on a regular basis.
- D. The ambient noise level from any machinery and equipment shall not exceed 65 dB during the day. Night work, if approved by the Town, shall not exceed 40 dB.

2.2 MATERIALS

- A. Polymers
 - A. The Contractor shall supply a low to medium cationic emulsion for mixing into the silt after removal of wet silt from the pond bottom. Cost of emulsion is subsidiary to the dewatering cost bid item.
 - B. A low to medium cationic emulsion such as Polydyne Clarifloc C6241 has proven effective in dewatering the wet silt after removal from the pond.
 - C. MSDS sheets shall be included in the Emulsion Plan, which shall be prepared by the Contractor and submitted for the Town's review.
 - D. The Contractor is responsible for storage and calculating required concentrations.
 - E. The Contractor shall monitor and adjust dosing and concentrations to maintain optimal dosing to the system.

PART 3 - EXECUTION

3.1 PREPARATION

- A. Protect structures, utilities, sidetrails, pavements, and other facilities from damage caused by dewatering operations.

- B. Preparation of subgrade for earthwork operations including removal of vegetation, topsoil, debris, obstructions, and deleterious materials from ground surface is specified in NCTCOG Division 3 Section "Site Preparation."
- C. Protect and maintain erosion and sedimentation controls in conformance all applicable federal, state, and local laws, regulations, permit conditions, and notification requirements.

3.2 MATERIAL TRANSPORT TO DEWATERING AREA:

- A. The excavated material shall be transported directly to the sediment dewatering area in a manner that reduces spills outside the project area.

3.3 PROTECTION

- A. Keep area free of trash and debris.
- B. Repair and reestablish grades to specified tolerances where completed or partially completed surfaces become eroded, rutted, settled, or where they lose compaction due to subsequent operations or weather conditions.
- C. In case of a spill emergency, the Contractor must notify the Town immediately and take immediate steps to mitigate the contamination. All mitigation techniques must meet all federal and state requirements.

3.4 RETURN OF WATER TO WATER SOURCE

- A. Effluent from the dewatering operation may not be pumped back to the creek system and must be disposed of properly.

3.5 DISPOSAL OF CLEAN FILTRATE

- A. The dewatering of silt operations shall have a 95 percent capture of solids from wet silt material. Only clean filtrate from the dewatering operation will be allowed to discharge into the City of Dallas sanitary sewer collection system. Discharge shall be flowed into the existing 12" line from the manhole located at Belt Line Road and Winnwood Road.

3.6 DISPOSAL OF WASTE MATERIALS

- A. Disposal: Dispose of waste material, including unsatisfactory soil, trash, and debris, and legally dispose of it off Owner's property.

END OF SECTION

SECTION 02243

AQUATIC SPECIES RECOVERY AND RELOCATION

PART 1 - GENERAL

In accordance with TPWD *Aquatic Resource Relocation Guidelines*, Chapters 67 and 68 (Sections 68.002 and 68.015) of the TPWD Code, and 31 Texas Administrative Code (TAC) §65.175 & 176, an *Aquatic Resource Relocation Plan* (ARRP) must be prepared by the responsible party (Town of Addison) and approved by TPWD prior to unwatering and/or desilting activities within the Winnwood Ponds. The ARRP will detail how the responsible party (Town of Addison) plans to control and limit the impacts of unwatering within the Winnwood Ponds and will be prepared by Halff Associates, Inc. (Halff) on behalf of the Town of Addison.

PART 2 - NOT USED

PART 3 - EXECUTION

The ARRP will include information on 11 specific elements for each location, in accordance with TPWD Guidelines. Per TPWD *Aquatic Resource Relocation Plan Guidelines*, the 11 elements to be included in the ARRP are as follows:

1. Exact location.
2. Purpose of the activity.
3. Notification to the regional Kills and Spills Team (KAST) biologist of the expected start date or any changes to the start date of fish recovery activities.
4. Method of collecting and moving the fishes.
5. Types and sizes of containers to be used.
6. Transportation methods and destination.
7. How the documentation and disposal of dead and non-native fishes will be handled.
8. The best management practices (BMPs) to be used to ensure that relocated fish and fish awaiting relocation have best possible water quality and have adequate carrying capacity for additional biomass (i.e., aerators, water depth at which fish relocation activities will begin).
9. Provide an estimation of the time expected to complete the fish removal operation.
10. Identify any state or federally threatened or endangered species that may occur. Explain what methods will be used to protect these species.
11. Identify all freshwater mussels that may become stranded due to the operation. Explain what methods will be used to protect the mussels.

Per TPWD *Aquatic Resource Relocation Plan Guidelines*, the ARRP must be supplied to TPWD by the responsible party (Town of Addison) no less than four weeks prior to the beginning of construction activities; therefore, the Construction Contractor shall coordinate with the Town of Addison and Halff regarding the anticipated date of construction. In addition, TPWD must issue a Permit to Introduce Fish, Shellfish or Aquatic Plants into Public Waters prior to unwatering/dewatering/desilting activities. Unwatering, dewatering, and/or desilting may not begin until TPWD approves the ARRP and issues the Permit to Introduce Fish, Shellfish or Aquatic Plants into Public Waters.

The Construction Contractor will be required to coordinate with Halff regarding the timing of the unwatering, dewatering, and/or desilting activities so that accurate and up to date information can be

provided by Halff to TPWD for ARRP approval and the issuance of the Permit to Introduce Fish, Shellfish or Aquatic Plants into Public Waters. The Construction Contractor will be notified by the Town of Addison and/or Halff upon TPWD approval of the ARRP and issuance of the Permit to Introduce Fish, Shellfish or Aquatic Plants into Public Waters.

All aquatic species recovery and relocation activities will be completed by Halff during and/or after the unwatering process and must be conducted in accordance with both the TPWD-approved ARRP and Permit to Introduce Fish, Shellfish or Aquatic Plants into Public Waters. The Construction Contractor will be required to perform the unwatering and/or desilting activities in accordance with the TPWD-approved ARRP.

Tasks to be Completed Prior to the Unwatering Process

The below is a table including information on general tasks and meetings to be held prior to the beginning of the construction process, the estimated timeframe for each task, and the responsible entity. The Construction Contractor will be required to attend two coordination meetings and will also be required to coordinate with Halff and the Town of Addison as necessary prior to the initiation of unwatering and/or desilting activities.

Task	Estimated Timeframe	Responsible Entity
Notify the Town of Addison and Halff to begin ARRP Preparation	3 months prior to the anticipated initiation of unwatering, dewatering, and/or desilting activities within the Winnwood ponds	Construction Contractor
Coordination/Pre-Construction meeting on ARRP requirements	During ARRP Preparation (see below)	Halff will organize; Construction Contractor, Halff, Town of Addison and/or TPWD will attend
Prepare the Draft ARRP	2-4 weeks	Halff
Submit Draft ARRP to Town of Addison for review/comment	1 week	Halff will submit; Town of Addison will review and provide comments
Revise Draft ARRP to address Town of Addison comments	1 week	Halff
Submit Revised Draft ARRP & Application for Permit to Introduce Fish, Shellfish or Aquatic Plants into Public Waters to TPWD for approval	2-4 weeks	Halff
Coordination meeting to schedule the unwatering and ARRP activities	1 week	Halff will organize; Construction Contractor, Halff, Town of Addison and/or TPWD will attend
Begin unwatering process per coordination with Halff & the TPWD-approved ARRP	As per coordinated schedule	Construction Contractor

Upon TPWD approval of the ARRP and the issuance of the Permit to Introduce Fish, Shellfish or Aquatic Plants into Public Waters by TPWD, the Construction Contractor shall attend one meeting with the Town of Addison and Halff as shown in the above table. During this meeting the unwatering activities will be scheduled and detailed coordination regarding the timing of the aquatic species recovery and relocation activities will occur.

The Construction Contractor must notify Halff at least 5 days prior to the initiation of the unwatering process so that staff may be scheduled to conduct aquatic species recovery and relocation activities in accordance with the TPWD-approved ARRP. Halff will then notify TPWD of the schedule for ARRP activities, per the Permit to Introduce Fish, Shellfish or Aquatic Plants into Public Waters requirements.

Tasks to be Completed During the Unwatering Process

The Construction Contractor will be required to be familiar with the TPWD-approved ARRP and must complete the unwatering process in a manner so that Halff may perform ARRP activities in accordance with the TPWD-approved ARRP.

- Construction Contractor shall not completely unwater the work area until Halff has arrived on-site to commence aquatic species recovery and relocation activities.
- Construction Contractor shall restrict public access to the work area during aquatic resource relocation activities.

Fish and Turtle Recovery and Relocation Activities

Halff will develop the appropriate methodology and conduct fish and turtle recovery and relocation efforts during the unwatering process. Fish recovery and relocation activities will be managed by Halff and conducted via electrofishing and/or seining. Turtle recovery and relocation activities will be conducted via dip netting and/or seining. Collected fish and turtles will be placed within an oxygenated holding tank and transported by Halff to the pre-selected relocation site. Recovered fish and turtles will then be relocated to an appropriate area, as determined by Halff. Fish and turtle recovery and relocation activities will be conducted in accordance with the TPWD-approved ARRP.

The exact timing of these activities will be dependent upon the Construction Contractor schedule, staff availability, conditions within the ponds (i.e., flow levels, etc.), and weather-related conditions. The Construction Contractor will be required to assist Halff, as needed, with boat access. In addition, the Construction Contractor must allow Halff to complete the required aquatic species relocation activities prior to the initiation of desilting or other construction activities within the Winnwood ponds.

Mussel Recovery and Relocation Activities

In accordance with Chapters 67 and 68 (Sections 68.002 and 68.015) of the TPWD Code and 31 TAC §65.175 & 176, a presence/absence survey for state-listed threatened mussels was conducted by Halff on April 9-10, 2014 within the three Winnwood Ponds. Each of these ponds will be surveyed by Halff during and/or upon completion of the unwatering process. A TPWD-permitted malacologist and other experienced biologists from Halff will be on site to survey the unwatered ponds for mussels that may have become stranded as a result of the unwatering process. Should any mussels be recovered, Halff will relocate mussels in accordance with the TPWD-approved ARRP. Mussels will be transported by Halff to an appropriate relocation site in coolers to maintain their temperature as close as possible to pond temperature, and the location of the relocated mussels will be documented. All recovery and relocation activities will be conducted by Halff in accordance with the TPWD-approved ARRP.

The exact timing of these activities will be dependent upon the Construction Contractor schedule, staff availability, conditions within the ponds (i.e., flow levels, etc.), and weather-related conditions. The

Construction Contractor must allow Halff to complete the required aquatic species relocation activities prior to the initiation of dewatering, desilting or other construction activities within the Winnwood ponds.

Best management practices (BMPs) will be utilized by Halff to prevent the transfer of invasive species. Throughout the mussel relocation process and upon completion of these activities, all equipment used to perform such tasks will be visually inspected by Halff for zebra mussels and/or other invasive species. Halff will remove plant material, mud, and other debris from all equipment utilized throughout the relocation activities (i.e., boots, buckets, nets, coolers, etc.) and will properly clean the equipment with a high pressure hose to be supplied by Halff. This equipment will then be allowed to dry completely before use in another water body in accordance with the TPWD rules currently in effect within Dallas County, Texas as well as the TPWD-approved ARRP.

Upon completion of ARRP activities, the Construction Contractor may work within the Winnwood ponds as necessary. The Construction Contractor will be required to notify Halff and the Town of Addison if there is a flood event that requires additional unwatering or if additional aquatic species including fish, turtles, and/or freshwater mussels are encountered within the ponds during construction activities performed by the Construction Contractor following the completion of aquatic species recovery and relocation activities performed by Halff during the unwatering process.

SECTION 02300

EARTHWORK FOR PAVEMENTS, TRAILS AND SLOPE PROTECTION

PART 1 - GENERAL

1.1 RELATED DOCUMENTS

- A. Drawings and general provisions of the Contract, including General and Supplementary Conditions apply to this Section.

1.2 SUMMARY

- A. This Section includes the following:
 - 1. Preparing subgrades for trails, pavements and slope protection.
 - 2. Excavating and backfilling.
 - 3. Subsurface drainage backfill for slope protection.
- B. Related Sections include the following:
 - 1. Section 01710 - Site Clearing for temporary erosion and sedimentation control measures, site stripping, grubbing, stripping and stockpiling topsoil, and removal of above- and below-grade improvements and utilities.
 - 2. Section 01732 - Demolition
 - 3. Section 02231 - Tree Protection for protecting and trimming trees to remain.
 - 4. Section 02212 - Embankment and Earthwork for Structures.

1.3 REFERENCED STANDARDS

- A. American Society for Testing and Materials (ASTM).
 - 1. C 33 - Standard Specification for Concrete Aggregates
 - 2. C 109 - Standard Test Method for Compressive Strength of Hydraulic Cement Mortars
 - 3. C 150 – Standard Specification for Portland Cement
 - 4. C 495 – Standard Test Method for Compressive Strength of Lightweight Insulating Concrete
 - 5. C 618 - Standard Specification for Coal Fly Ash and Raw or Calcined Natural Pozzolan for Use in Concrete
 - 6. D 3740 - Standard Practice for Minimum Requirements for Agencies Engaged in the Testing and/or Inspection of Soil and Rock
 - 7. E 329 - Standard Specification for Agencies Engaged in Construction Inspection and/or Testing
 - 8. E 548 – Standard Guide for General Criteria Used for Evaluating Laboratory Competence

1.4 DEFINITIONS

- A. Base Course: Course placed between the subgrade.
- B. Borrow Soil: Satisfactory soil imported from off-site for use as fill or backfill.

- C. Drainage Course: Course supporting the slope protection that also minimizes upward capillary flow of pore water.
- D. Excavation: Removal of material encountered above subgrade elevations and to lines and dimensions indicated.
 - 1. Authorized Additional Excavation: Excavation below subgrade elevations or beyond indicated lines and dimensions as directed by Engineer. Authorized additional excavation and replacement material will be paid for according to Contract provisions for changes in the Work.
 - 2. Unauthorized Excavation: Excavation below subgrade elevations or beyond indicated lines and dimensions without direction by Engineer. Unauthorized excavation, as well as remedial work directed by Engineer, shall be without additional compensation.
- E. Fill: Soil materials used to raise existing grades.
- F. Structures: Buildings, footings, foundations, retaining walls, slabs, tanks, curbs, mechanical and electrical appurtenances, or other man-made stationary features constructed above or below the ground surface.
- G. Subgrade: Surface or elevation remaining after completing excavation, or top surface of a fill or backfill immediately below pavement, subbase, drainage fill, or topsoil materials. Where indicated on the plans, lime stabilize the top 6 inches of subgrade in accordance with NCTCOG Item 4.6. Where lime stabilization is required, stabilization shall extend 1 foot beyond the back-of-curb or edge of pavement.
- H. Utilities: On-site underground pipes, conduits, ducts, and cables, as well as underground services within buildings.

1.5 SUBMITTALS

- A. Product Data: For the following:
 - 1. Each type of plastic warning tape.
 - 2. Controlled low-strength material (flowable fill), including design mixture.
- B. Material Test Reports: From a qualified testing agency indicating and interpreting test results for compliance of the flowable fill concrete.
- C. Preexcavation Photographs or Videotape: Show existing conditions of adjoining construction and site improvements, including finish surfaces that might be misconstrued as damage caused by earthwork operations. Submit before earthwork begins.

1.6 QUALITY ASSURANCE

- A. Geotechnical Testing Agency Qualifications: An Owner engaged testing agency qualified according to ASTM E 329 to conduct soil materials and rock-definition testing, as documented according to ASTM D 3740 and ASTM E 548.
- B. Preexcavation Conference: Conduct conference at Project site.

1.7 PROJECT CONDITIONS

- A. Existing Utilities: Do not interrupt utilities serving facilities occupied by Owner or others unless permitted in writing by Engineer and then only after arranging to provide temporary utility services according to requirements indicated.
 - 1. Notify Engineer not less than two days in advance of proposed utility interruptions.
 - 2. Do not proceed with utility interruptions without Engineer's written permission.
 - 3. Contact utility-locator service for area where Project is located before excavating.
- B. Coordinate with utility companies to shut off services if lines are active, as necessary.
- C. Subsurface Conditions: Logs of borings represent only the conditions at the point of the boring at the time the boring was made. The data given may or may not correspond to the conditions encountered by the contractor, and minor variation will not be used as a basis for a claim of changed conditions. The Contractor may take borings at the site to satisfy himself as to subsurface conditions.

PART 2 - PRODUCTS

2.1 EQUIPMENT

- A. The Contractor may use any excavating and hauling equipment adaptable to the work and any method generally accepted for this type of work. Refer to Drawings for equipment limitations on the spillway pavement and limestone outcroppings within the spillway. No equipment shall be allowed within the areas indicated on the drawings.
- B. Compaction equipment weighing 2,000 lbs or less shall be used within 5 feet of walls.

2.2 CONTROLLED LOW-STRENGTH MATERIAL (Flowable Backfill)

- A. Flowable Backfill: Low-density, self-compacting, flowable concrete material in accordance with NCTCOG Item 504.2.3.4 and as follows:
 - 1. Average Compressive Strength: 250 psi to 450 psi at 28 days.
 - 2. Portland Cement: ASTM C 150, Type I or III.
 - 3. Fly Ash: ASTM C 618, Class C or F.
 - 4. Aggregate: Mixture of imported sand or granular material, PI < 12, 100% passing ¾ -in sieve.
- B. Produce low-density, controlled low-strength material with the following physical properties:
 - 1. Compressive Strength: 250-450 psi after 28 days when tested according to ASTM C 495.

2.3 ACCESSORIES

- A. Warning Tape: Acid- and alkali-resistant polyethylene film warning tape manufactured for marking and identifying underground utilities, 6 inches wide and 4 mils thick, continuously inscribed with a description of the utility; colored as follows:

PART 3 - EXECUTION

3.1 PREPARATION

- A. Protect structures, utilities, sidetrails, pavements, and other facilities from damage caused by settlement, lateral movement, undermining, washout, and other hazards created by earthwork operations.
- B. Preparation of subgrade for earthwork operations including removal of vegetation, topsoil, debris, obstructions, and deleterious materials from ground surface is specified in NCTCOG Division 3 Section "Site Preparation."
- C. Protect and maintain erosion and sedimentation controls in conformance with the Texas Commission of Environmental Quality (TCEQ) permit requirements.

3.2 UNWATERING

- A. Refer to Section 02240 for Unwatering Requirements

3.3 EXPLOSIVES

- A. Explosives: Do not use explosives.

3.4 EXCAVATION, GENERAL

- A. **Unclassified Excavation:** Excavate to subgrade elevations regardless of the character of surface and subsurface conditions encountered. Unclassified excavated materials may include rock, soil materials, and obstructions. No changes in the Contract Sum or the Contract Time will be authorized for rock excavation or removal of obstructions.
 - 1. If excavated materials intended for fill and backfill include unsatisfactory soil materials and rock, replace with satisfactory soil materials.
- B. Refer to Sections 02240, "Unwatering", and 02242, "Dewatering".

3.5 EXCAVATION FOR STRUCTURES

- A. Refer to Section 02212, "Embankment and Earthwork for Structures".

3.6 EXCAVATION FOR TRAILS AND PAVEMENTS

- A. Excavate surfaces under trails and pavements to indicated lines, cross sections, elevations, and subgrades.

3.7 EXCAVATION FOR UTILITY TRENCHES

- A. Refer to NCTCOG Item 6.2 with applicable Town of Addison amendments.

3.8 SUBGRADE INSPECTION

- A. Notify Engineer when excavations have reached required subgrade.

- B. If Engineer determines that unsatisfactory soil is present, continue excavation and replace with compacted backfill or fill material as directed.
- C. Where concrete slope protection replacement is identified on the plans, notify Engineer when existing concrete slope protection has been removed to schedule inspection of subgrade conditions on and adjacent to slopes, channel bottom, and drop structure.
 - 1. Repair all voids, depressions, soft pockets and areas of excess yielding. Properly bench slopes to restore stability of the subgrade.
 - 2. Where voids are located in confined areas or beneath existing slabs or structures, voids shall be completely filled with a pumpable, non-shrink sand-cement grout mixture made from Type II and III Portland cement conforming to ASTM C150 and providing a minimum compressive strength of 3000 psi in accordance with ASTM C109.
- D. Proof-roll subgrade for trails and pavements with heavy pneumatic-tired equipment to identify soft pockets and areas of excess yielding. Do not proof-roll wet or saturated subgrades.
 - 1. Completely proof-roll subgrade in one direction, repeating proof-rolling in direction perpendicular to first direction. Limit vehicle speed to 3 mph (5 km/h).
 - 2. Proof-roll with a loaded 10-wheel, tandem-axle dump truck weighing not less than 15 tons.
 - 3. Excavate soft spots, unsatisfactory soils, and areas of excessive pumping or rutting, as determined by Engineer, and replace with compacted backfill or fill as directed.
- E. Authorized additional excavation and replacement material will be paid for according to Contract provisions for changes in the Work.
- F. Reconstruct subgrades damaged by freezing temperatures, frost, rain, accumulated water, or construction activities, as directed by Engineer, without additional compensation.

3.9 UNAUTHORIZED EXCAVATION

- A. Fill unauthorized excavation under all construction as directed by Engineer.

3.10 STORAGE OF SOIL MATERIALS

- A. Stockpile borrow soil materials and excavated satisfactory soil materials without intermixing. Place, grade, and shape stockpiles to drain surface water. Cover to prevent windblown dust.
 - 1. Stockpile soil materials away from edge of excavations. Do not store within drip line of remaining trees.

3.11 BACKFILL

- A. Place and compact backfill in excavations promptly, but not before completing the following:
 - 1. Construction below finish grade including, where applicable, subdrainage and utilities.
 - 2. Surveying locations of underground utilities for Record Documents.
 - 3. Testing and inspecting underground utilities.
 - 4. Removing concrete formwork.
 - 5. Removing trash and debris.
- B. Place backfill on subgrades free of mud, frost, snow, or ice.

3.12 GRADING

- A. General: Uniformly grade areas to a smooth surface, free of irregular surface changes. Comply with compaction requirements and grade to cross sections, lines, and elevations indicated.
 - 1. Provide a smooth transition between adjacent existing grades and new grades.
 - 2. Cut out soft spots, fill low spots, and trim high spots to comply with required surface tolerances.
- B. Site Grading: Slope grades to direct water away from structures and to prevent ponding. Finish subgrades to required elevations within the following tolerances:
 - 1. Trails: Plus or minus 1/2 inch.
 - 2. Pavements: Plus or minus 1/2 inch.

3.13 SUBSURFACE DRAINAGE

- A. Subdrainage Pipe: Specified in NCTCOG Item 2.12.24 Section "Polyethylene (PE) Corrugated and Corrugated Smooth Lined Storm Sewer and Drainage Tubing and Fittings."
- B. Subsurface Drain: Place subsurface drainage geotextile around perimeter of subdrainage trench. Place a 6-inch (150-mm) course of filter material on subsurface drainage geotextile to support subdrainage pipe. Encase subdrainage pipe in a minimum of 12 inches (300 mm) of filter material, placed in compacted layers 6 inches (150 mm) thick, and wrap in subsurface drainage geotextile, overlapping sides and ends at least 6 inches (150 mm).
 - 1. Compact each filter material layer to 85 percent of maximum dry unit weight according to ASTM D 698 with a minimum of two passes of a plate-type vibratory compactor.

3.14 BASE COURSE

- A. Place base course on subgrades free of mud, frost, snow, or ice.
- B. On prepared subgrade, place base course under pavements and trails as follows:
 - 1. Install separation geotextile on prepared subgrade where directed by Engineer and according to manufacturer's written instructions, overlapping sides and ends.
 - 2. Place base course material under hot-mix asphalt pavement.
 - 3. Shape base course to required crown elevations and cross-slope grades.
 - 4. Place base course 6 inches or less in compacted thickness in a single layer.
 - 5. Place base course that exceeds 6 inches in compacted thickness in layers of equal thickness, with no compacted layer more than 6 inches thick or less than 3 inches thick.
 - 6. Compact base course at optimum moisture content to required grades, lines, cross sections, and thickness to not less than 95 percent of maximum dry unit weight according to ASTM D 698.

3.15 PROTECTION

- A. Protecting Graded Areas: Protect newly graded areas from traffic, freezing, and erosion. Keep free of trash and debris.
- B. Repair and reestablish grades to specified tolerances where completed or partially completed surfaces become eroded, rutted, settled, or where they lose compaction due to subsequent construction operations or weather conditions.

1. Scarify or remove and replace soil material to depth as directed by Engineer; reshape and recompact.
 - C. Where settling occurs before Project correction period elapses, remove finished surfacing, backfill with additional soil material, compact, and reconstruct surfacing.
 1. Restore appearance, quality, and condition of finished surfacing to match adjacent work, and eliminate evidence of restoration to greatest extent possible.
- 3.16 DISPOSAL OF SURPLUS AND WASTE MATERIALS
- A. Disposal: Remove surplus waste material, including unsatisfactory soil, trash, and debris, and legally dispose of it off Owner's property.

END OF SECTION

SECTION 32 01 90

90 DAY ESTABLISHMENT PLANTING

PART 1 GENERAL

1.1 SECTION INCLUDES

- A. Scheduling of maintenance
- B. Monitoring, adjustment and repair of sprinkler irrigation.
- C. Mowing, edging and trimming of lawn areas.
- D. Pruning and trimming of trees and shrubs.
- E. Weeding of lawn and bed areas.
- F. Application of fertilizers and pesticides.
- G. General site cleanup and removal of trash.
- H. Provide long term landscape maintenance instructions.
- I. Cold Weather Maintenance of Irrigation System

1.2 RELATED SECTIONS

- A. Section 32 93 00 – Landscape Planting

1.3 REFERENCES

- A. ANSI Z60.1 -American Standard for Nursery Stock; 1996.
- B. ANSI A300 -American National Standard for Tree Care Operations --Tree, Shrub and Other Woody Plant Maintenance --Standard Practices; 1995.

1.4 QUALITY ASSURANCE

- A. Requirements of Regulatory Agencies:
 - 1. Perform all work in accordance with all applicable laws, codes, and regulations required by authorities having jurisdiction over such work.
 - 2. Provide for all inspections and permits required by Federal, State, or local authorities in furnishing, transporting, and installing of all agricultural chemicals.
 - 3. Provide monthly records of all fertilizers and pesticides used for the project.

B. Work Force:

1. Experience: The landscape establishment firm shall have a full time foreman assigned to the job for the duration of the contract. He shall have a minimum of four years' experience in landscape establishment supervision, with experience or training in turf management, entomology, pest control, soils, fertilizers and plant identification.
2. Labor Force: The landscape establishment firm's labor force shall be thoroughly familiar and trained in the work to be accomplished and perform the task in a competent, efficient manner acceptable to the Owner.
3. Supervision: The designated foreman shall directly supervise the work force at all times. Notify the Owner of all changes in supervision.
4. Identification: Provide proper identification at all times for landscape establishment firm's labor force. Be uniformly dressed in a manner satisfactory to the Owner.

1.5 QUALITY ASSURANCE

- A. See Section 01330 -Submittal Requirements, for submittal procedures, if applicable.
- B. Prior to commencing the landscape installation, submit to Owner's Representative for approval, two (2) copies each of the following items:
 1. Proposed schedule of establishment operations.
 2. All licenses and insurances required by the Owner, Town of Addison, County of Dallas, State of Texas, or any other entity, pertaining to this work.
- C. During the landscape establishment period at monthly intervals submit to Owner's Representative two (2) copies each of the following items:
 1. Written application recommendation by a licensed pesticide applicator for any proposed weed, pest and disease control which is intended to be used where restrictions are required by the Department of Agriculture.
 2. Provide monthly records of all fertilizers and pesticides used for the project.
 3. Provide each month of the establishment period, written reports and logs as follows:
 - a. Provide monthly status report of site conditions outlined weekly.
 - b. Provide monthly status report of irrigation controller operations and adjustments required.
- D. Submit to the Owner's Representative written maintenance instructions as outlined below.

1.6 SCHEDULING

- A. Perform all establishment during hours mutually agreed upon between Owner and Contractor.
- B. Work force shall be present at the project site at least once a week, and as often as necessary, to perform specified establishment in accordance with the approved establishment schedule.

1.7 PROJECT CONDITIONS

- A. Site Visit: At beginning of establishment period, visit and walk the site with the Owner's Representative to clarify scope of work and understand existing project/site conditions.
- B. Documentation of Conditions: Document general condition of existing trees, shrubs, vines, ground covers and lawn and replace all plant materials which are damaged or dying, if any.
- C. Irrigation System: Document general condition of existing irrigation system, making sure that faulty electrical controllers, broken or inoperable sprinklers are repaired or replaced.

1.8 CONTRACTOR RESPONSIBILITIES

- A. The Contractor shall begin maintenance after any portion of the sprinkler irrigation, any plant or any lawn portion is installed. The cost of landscape maintenance until the end of the ninety (90) day establishment period will be at the expense of the Contractor.
- B. The Contractor's establishment period shall begin upon inspection and approval at Final Completion and shall be for a minimum of ninety (90) days. Should the contractor's own work prevent Final Acceptance of the site, the site shall be maintained at the Contractor's expense until Final Acceptance of the Contractor's work. The ninety-day establishment period will start only upon Final Acceptance of the Work by the Owner.
- C. Sprinkler Irrigation System: Monitor and adjust the duration and frequency of the watering schedule, adjustment of heads for coverage and elevation, repair leaks, and all other work required to maintain a complete working sprinkler irrigation system.
- D. Trees, Shrubs, Ground covers and Vines: The Contractor's responsibilities for the new planting shall consist of, but not be limited to; watering, fertilization, weeding, mulching, re-staking, adjustment of tree staking and/or guying, resetting plants to proper grades or upright position, maintenance of the tree rings, and protecting the plantings from insects and disease infestation.
- E. Lawns: The Contractor's maintenance of new lawns shall consist of weekly mowing, edging, watering, fertilization, weeding, repair of all erosion and reseeding and re-sodding as necessary to establish a full and uniform stand of the specified grasses.

1.9 PROTECTION

- A. Protect planting areas and lawns at all times against damage of all kinds for duration of maintenance period. Maintenance includes temporary protection fences, barriers and signs as required for protection. If any plants become damaged or injured, because

sufficient protection was not provided, treat or replace as directed by Owner at no additional cost to the Owner.

1.10 FINAL ACCEPTANCE

- A. Work under this Section will be accepted by the Owner's Representative upon satisfactory completion of all work, including establishment, but exclusive of the required guaranteed sprinkler irrigation obligations, replacement of plant materials and lawns under the Warranty Period. Upon Final Acceptance, the Owner will assume responsibility for maintenance of the work. This assumption will not relieve the Contractor of his warranty obligations.

1.11 WARRANTIES AND REPLACEMENTS

- A. Refer to Sections 32 93 00 Landscape Planting; Coordinate with the Town of Addison

1.12 MAINTENANCE INSTRUCTIONS

- A. At the completion of work, furnish two (2) copies of written maintenance instructions to the Owner and one (1) copy to the Owner's Representative for maintenance and care of the sprinkler irrigation system, lawns and all planting area throughout the year.

PART 2 PRODUCTS

2.1 MATERIALS

- A. All materials and equipment necessary for maintenance operations will be provided by the Contractor. The selection of materials to be used for maintenance operations will be left to the discretion of the Contractor. Any materials, and the application of those materials, must comply with all federal, state, county, city and local laws and codes. The Contractor shall use established and accepted horticultural practices. Failure to do so may result in plant replacement at the Contractor's expense.
- B. Water: Clean, potable and fresh, furnished and paid for by the Owner.
- C. Annuals/Perennials: Nursery-grown in pots, full, healthy plants just ready to bloom matching on site materials.
- E. Lawn Sod for Resodding: Match existing sodded lawn.
- F. Tree Guys, Stakes, Ties and Wires: Provide detail(s) in 8-1/2 in. x 11 in. format for staking which will vary from the site staking due to unusual or unknown site conditions.

2.2 REQUIRED MAINTENANCE EQUIPMENT

- A. Contractor's option, well maintained in first class condition, capable of successfully executing the work.

PART 3 EXECUTIONS

3.1 GENERAL

- A. Duration: Continuously maintain all landscape areas after installation, during progress of work, and for a period of no less than ninety (90) days after Final Acceptance of all planting work.
- B. Protection:
 - Protect all planting areas from damage from beginning of work until the end of the ninety-day establishment period.
 - Establishment includes temporary protection fences, barriers and signs as required for protection.
- C. Replacements:
 - Immediately replace all plants that become damaged or injured, as directed by the Owner's Representative at no additional cost to the Owner.
 - Replacement plants shall be of the size, condition and variety originally installed.

3.2 DEBRIS AND LITTER REMOVAL

- A. It shall be the responsibility of the Contractor to inspect the site weekly and remove all litter and debris accumulations.

3.3 SUPPLEMENTAL WATERING

- A. It shall be the responsibility of the Contractor to assure that the correct watering of plant materials is being accomplished through the use of the irrigation system, hand-watering, 'gator' bags, water truck, etc.
- B. Contractor shall monitor settings of automatic sprinkler controls and make necessary adjustments according to climatic changes.
- C. Contractor shall not be responsible for supplemental watering areas that do not have irrigation systems, unless required by the Contract.
- D. Contractor shall be responsible for damages to irrigation system caused by mowing and other maintenance operations. Such damage will be repaired immediately at the Contractor's expense.

3.4 TREES, SHRUBS AND VINES

- A. General:
 - 1. The Contractor shall use established and accepted horticultural practices in the care of the plant material.
 - 2. Maintain originally specified depth of mulch to reduce evaporation and frequency of watering.
 - 3. Check for moisture penetration throughout the root zone at least once per week.

B. Weed Control:

1. All materials and equipment necessary for maintenance operations will be provided by the Contractor. The selection of materials to be used for maintenance operations will be left to the discretion of the Contractor. Any materials, and the application of those materials, must comply with all federal, state, county, city and local laws and codes. The Contractor shall use established and accepted horticultural practices. Failure to do so may result in plant replacement at the Contractor's expense.
2. All lawn areas, tree rings and planting areas will be maintained in a healthy weed-free condition.

C. Pruning:

1. Remove any broken, damaged, or crossing branches not removed at installation.
2. No stripping of lower branches ('raising' or 'skirting') or cutting back ('heading' or 'topping') of trees will be permitted. The Contractor shall use established and accepted horticultural practices in the care of the plant material.
3. Prune damaged trees or those that constitute health or safety hazards at any time of year as required.
4. Do not use pruning paint or pruning compounds on pruning cuts. Allow the cuts to callous naturally.
5. Do not prune or clip shrubs into balled or boxed forms unless specifically called for by design.

3.5 GROUNDCOVERS

A. Watering:

- Check for moisture penetration throughout the root zone at least twice a month.
- Water as frequently as necessary to maintain healthy growth of ground covers.

B. Weed Control:

- All planting areas will be maintained in a healthy weed-free condition by the use of pre-and post-emergent herbicides or hand-pulling.
- To avoid root damage to young plants, minimize weed growth and protect the chemical barrier of pre-emergent herbicides, cultivation of beds and tree wells will not be permitted.

3.6 LAWNS

A. Watering:

1. Water lawns at such frequency as weather conditions require replenishing soil moisture to 6 in. below soil surface.
2. Apply enough water to newly sodded areas to wet the soil to a depth of 2"-3" (approx. ¼ inch in clay soils). In newly seeded areas; provide only enough water to keep the soil surface moist, but not water logged. In established lawn areas, apply enough water to wet the soil to a depth of 6" (approx. ½ inch in clay soils). These application rates are suggestions only. The frequency and actual duration of watering cycles will vary according to weather, soil type, slopes, etc. The contractor will be solely responsible for providing the optimum watering schedule for the project.
3. In established areas, water during early morning hours when the wind is calmest.

B. Weed Control:

1. All lawn areas will be maintained in a healthy weed-free condition by the use of pre- and post-emergent herbicides or hand-pulling. Any materials, and the application of those materials, must comply with all federal, state, county, city and local laws and codes. The Contractor shall use established and accepted horticultural practices. Failure to do so may result in plant replacement at the Contractor's expense.
2. Provide the Owner with 48 hour notice of chemical applications. Within 48 hours of application, provide Owner with a copy of the applicator's log book showing the time, date, and type and amount of chemical used.

C. Mowing and Edging:

1. Mowing lawn/grass areas shall be accomplished with sharp, properly adjusted mowers of the correct size for the various areas
2. Mowing frequency shall be weekly. Blade heights shall be set according to the type of turf and weather conditions.
3. Trim edges with each mowing or as required for neat appearance. Edging shall be performed with a blade type mechanical edger, shovel or herbicide. String whips shall not be permitted. Remove clippings.

D. In the event of a prolonged rainy period and a surge of leaf growth is anticipated, the mower height may be re-adjusted to prevent "scalping" or skinning of lawn on preceding cuts. At no time shall more than 1/3 of the leaf blade be removed in one mowing.

E. Lawn Fertilizer: Applied during the establishment period at 45 days after turf installation.

1. Preparation: Water areas to receive fertilizer 48 hour prior to application. Allow leaf surface to dry before fertilizer application. Do not apply fertilizer to turf wet from dew, rain or irrigation. Water lightly after application to remove fertilizer granules from leaf blades.
2. Application: Apply no more than ½ lb. of actual nitrogen per 1000 square feet.

3. Resodding of Lawn Areas: Match existing sodded lawn.
 - a. Until the establishment of the turf, the Contractor will be responsible for replacing soils that have eroded onto the paved areas. Residual soils on paving will be removed and if not mingled with objectionable materials, may be re-used in eroded areas.
 - b. Immediately upon observing any lawn grass spreading into shrub or ground cover areas, the Contractor shall initiate a program of mechanical removal and maintain this program throughout the maintenance period.
 - c. Treat any lawn grass appearing in paved areas with a non-selective foliar herbicide. Do not use brush killers or soil sterilants.
4. Special effort shall be given to the control of fire ants infesting the site. After control is accomplished, the ant mounds shall be removed.

3.7 ANNUALS AND PERENNIALS

- A. Care for all seasonal color and perennial beds per established and accepted horticultural practices. Failure to use proper horticultural practices may result in replacement of the plant material at the Contractor's expense.
- B. Weed Control: All planters with annuals and perennials shall be weed-free at all times.
- C. Pruning:
 - Limit pruning to removal of damaged or dead twigs and foliage.
 - Remove spent flowers on a weekly basis.
- D. Replacements of Annuals:
 - Replace annuals when materials exhibit a "spent" condition or as directed by the Owner or Landscape Architect.
 - Thoroughly cultivate soil, incorporate slow release fertilizers and rake smooth.

3.8 INSECTS, PESTS, AND DISEASE CONTROL

- A. Contractor shall be continuously alert for signs of the presence of insect or disease infestation. The Contractor shall immediately take action to control to infestation. Plant material that is damaged or that dies from insect or disease infestation while under the Contractor's care shall be immediately replaced at the Contractor's expense.
- B. Application: Perform spraying for insect, pest and disease control only by licensed personnel. Spray with extreme care to avoid all hazards to any person or animals in the area or adjacent areas.

3.9 IRRIGATION SYSTEM

A. General:

1. Repair without charge to the Owners all damages to system caused by Contractor's operations. Perform all repairs within 24 hours of the damage occurring.
2. Report promptly to the Owner all accidental damage not resulting from Contractor's negligence or operations.
3. Do not run the irrigation system during periods of rain. Set and program automatic controllers for seasonal water requirements.
4. Twice a month, use a probe or other acceptable tool to check the root ball moisture of representative plants as well as the surrounding soil.

B. Cleaning and Monitoring the System:

1. Continually monitor the irrigation systems to verify that they are functioning properly as designed. Make program adjustments required by changing field conditions.
2. If applicable clean pump filter and strainer as often as necessary to keep the irrigation systems free of sand and other debris.
3. Prevent spraying on windows, building walls, (game courts) by balancing the flow control on the remote control valves and the adjustment screws on the sprinkler heads. Do not allow spray to atomize and drift.

- C. Winterization: Normally, the irrigation system should be left operational during the winter. While the frequency may be as little as one cycle per month, the landscape will need supplemental water if winter rainfall is not adequate.

Should winterization be necessary, the Contractor shall take any and all steps necessary to protect the irrigation system. It shall also be the Contractor's responsibility to take whatever steps necessary to protect the landscape and pavement from icing caused by the irrigation system.

The Contractor will re-activate the system as soon as the freezing conditions have ended.

3.10 THE 90-DAY ESTABLISHMENT PERIOD

- A. Preliminary Review: As soon as all plantings are completed per Contract Documents, hold a preliminary review to determine the condition of the work.
- B. Date of Review: Submit a written request to the Owner's Representative at least five (5) working days prior to anticipated date of review.
- C. Beginning of the 90-Day Establishment Period: The date on which the Owner's Representative issues a letter of Preliminary Acceptance to the Contractor. Generally, the date of final acceptance of the landscape.

3.11 FINAL ACCEPTANCE

- A. Acceptance:
 - 1. Work will be accepted by the Owner's Representative upon satisfactory completion of all work, including establishment period, but exclusive of replacement of materials under the Warranty Period.
 - 2. Submit a written request to the Owner's Representative for review for Final Acceptance at least five (5) working days prior to the anticipated Final Review date, which is at the end of the Establishment Period.
- B. Corrective Work:
 - 1. Work requiring corrective action or replacement in the judgment of the Owner's Representative shall be performed within ten (10) calendar days after the Final Review.
 - 2. Corrective work and materials replacement shall be performed in accordance with the Drawings and Specifications, and shall be made by the Contractor at no cost to the Owner.
 - 3. After corrective work is completed, the Contractor shall again request a Final Review for Final Acceptance as outlined above.
 - 4. Continue establishment of all landscaped areas until such time as all corrective measures have been completed and accepted.
- C. Conditions for Acceptance of Work at End of Establishment Period:
 - 1. Green grass shall cover at least 75% of the area indicated in the plans as requiring sod and any other locations where grass is disturbed during construction. The grass shall be alive and thriving, showing signs of growth and no signs of stress, disease, or any other weaknesses.
 - 2. Each plant shall be alive and thriving, showing signs of growth and no signs of stress, disease, or any other weaknesses.
 - 3. All grasses and plants not meeting these conditions shall be replaced and a 90 Day Establishment Period commenced for such plants.
- D. Owner's Acceptance of the Work: Upon completion of the ninety (90) establishment period and installation of all warranty replacements, the Owner will assume responsibility for maintenance of the work.

3.12 CLEAN-UP

- A. All areas shall be kept neat and orderly at all times. Debris from maintenance operations shall be gathered and shall not be allowed to remain in place in excess of two (2) hours. Remove all such debris from the site at the end of each day.

END OF SECTION

SECTION 32 01 92

LANDSCAPE MAINTENANCE (1 YEAR)

PART 1 GENERAL

1.1 SECTION INCLUDES

- A. Scheduling of maintenance
- B. Monitoring, adjustment and minor repair of sprinkler irrigation.
- C. Mowing, edging and trimming of lawn areas.
- D. Pruning and trimming of trees and shrubs.
- E. Weeding of mulched areas.
- F. Application of fertilizers, insecticides, and herbicides.
- G. General site cleanup; removal of trash and products of maintenance.
- H. Provide long-term landscape maintenance instructions.
- I. Winterization of Irrigation System (if applicable)

1.2 RELATED SECTIONS

- A. Section 32 92 23 – Sodding
- B. Section 32 93 00 – Landscape Planting

1.3 REFERENCES

- A. ANSI Z60.1 -American Standard for Nursery Stock; 1996.
- B. ANSI A300 -American National Standard for Tree Care Operations --Tree, Shrub and Other Woody Plant Maintenance --Standard Practices; 1995.

1.4 QUALITY ASSURANCE

- A. Requirements of Regulatory Agencies:
 - 1 Perform all work in accordance with all applicable laws, codes, and regulations required by authorities having jurisdiction over such work.
 - 2 Provide for all inspections and permits required by Federal, State, or local authorities in furnishing, transporting, and installing of all agricultural chemicals.
 - 3 Provide monthly records of all fertilizers and pesticides used for the project.
- B. Work Force:
 - 1. Experience: The landscape establishment firm shall have a full time foreman assigned to the job for the duration of the contract. He shall have a minimum of four years experience in landscape establishment supervision, with experience or training in turf management, entomology, pest

- control, soils, fertilizers and plant identification.
- 2. Labor Force: The landscape establishment firm's labor force shall be thoroughly familiar and trained in the work to be accomplished and perform the task in a competent, efficient manner acceptable to the Owner.
- 3. Supervision: The designated foreman shall directly supervise the work force at all times. Notify Owner of all changes in supervision.
- 4. Identification: Provide proper identification at all times for landscape establishment firm's labor force. Be uniformly dressed in a manner satisfactory to the Owner.

1.5 SUBMITTALS

- A. Prior to commencing the landscape installation, submit to Owner's Representative for approval, two (2) copies each of the following items:
 - 1. Proposed schedule of maintenance operations.
 - 2. All licenses and insurances required by the owner, Town of Addison, or any other entity, pertaining to this work.
- B. During the landscape maintenance period at monthly intervals submit to Owner's Representative two (2) copies each of the following items:
 - 1. Written application recommendation by a licensed agricultural pest control advisor for any proposed weed, pest and disease control which is intended to be used where restrictions are required by the Department of Agriculture.
 - 2. Provide weekly records of all fertilizers, herbicides, insecticides and disease control methods used for the project
 - 3. Provide each month of the maintenance period, written reports and logs as follows:
 - a. Provide monthly status report of site conditions outlined weekly.
 - b. Provide monthly status report of irrigation controller operations and adjustments required.
- C. Submit to Owner's Representative written maintenance instructions as outlined below.

1.6 SCHEDULING

- A. Perform all maintenance during hours mutually agreed upon between Owner and Contractor.
- B. Work force shall be present at the project site at least twice a week and as often as necessary to perform specified maintenance in accordance with the approved maintenance schedule.

1.7 PROJECT CONDITIONS

- A. Site Visit: Prior to the beginning of the 1-year maintenance period, visit and walk the site with the Owner's representative to clarify scope of work and understand existing project/site conditions.
- B. Documentation of Conditions: Document general condition of existing trees, shrubs, vines, ground covers and lawn recording all plant materials which are damaged or dying, if any.
- C. Irrigation System: Document general condition of existing irrigation system, making sure that faulty electrical controllers, broken piping are repaired or replaced

1.8 CONTRACTOR RESPONSIBILITIES

- A. The Contractor shall begin one year maintenance after receiving written notice to proceed from the Owner (following completion of 90 day establishment period, reference Section 32 01 90). At this time, the contractor will be responsible for any and all existing conditions in regard to the landscape

planting and irrigation system.

- B. Sprinkler Irrigation System: Monitor and adjust The Contractor's maintenance of the sprinkler irrigation system shall consist of monitoring and adjustment of the duration and frequency of the watering schedule, adjustment of heads for coverage and elevation, repair leaks in both mains and lateral lines, and all other work required to maintain a complete working sprinkler irrigation system.
- C. Trees, Shrubs, Ground Covers and Vines: The Contractor's responsibilities for maintenance of the new planting shall consist of, but not be limited to; watering, fertilization, weeding, mulching, re-staking, adjustment of tree staking and/or guying, resetting plants to proper grades or upright position, maintenance of the tree rings, and protecting the plantings from insects and disease infestation.
- D. Lawns: The Contractor's maintenance of lawns shall consist of, but not be limited to, weekly mowing, edging, watering, fertilization, weeding, repair of all erosion and reseeding and re-sodding as necessary to maintain a full, uniform and weed-free stand of the specified grasses.

1.9 PROTECTION

- A. Protect planting areas and lawns at all times against damage of all kinds for duration of maintenance period. Maintenance includes temporary protection fences, barriers and signs as required for protection. If any plants become damaged or injured, because sufficient protection was not provided, treat or replace as directed by Owner at no additional cost to Owner.

1.10 WARRANTIES AND REPLACEMENTS

- A. Plant material that dies under the care of the contractor shall be replaced by material of equal size and quality at no cost to the Owner. Damage to the site and/or irrigation system resulting from maintenance activities shall be repaired at no cost to the Owner.

PART 2 PRODUCTS

2.1 MATERIALS

- A. General: All materials and equipment necessary for maintenance operations will be provided by the Contractor. The selection of materials to be used for maintenance operations will be left to the discretion of the Contractor. Any materials, and the application of those materials, must comply with all federal, state, county, city and local laws and codes. The Contractor shall use established and accepted horticultural practices. Failure to do so may result in plant replacement at the Contractor's expense.
- B. Materials required for replacement of installed items shall match those already in use.
- C. Samples of all materials not specified under other Sections of these Specifications shall be submitted for review by Owner's Representative prior to use.
- D. Water: Clean, potable and fresh, furnished and paid for by the Owner.
- E. Annuals/Perennials: Nursery-grown in pots, full, healthy plants just ready to bloom matching on site materials.
- G. Lawn Sod for Re-sodding: Match existing sodded lawn.

- H. Replacement Tree Guys, Stakes, Ties and Wires: Match existing materials on the site. Provide detail(s) in 8-1/2 in. x 11 in. format for staking which will vary from the site staking due to unusual or unknown site conditions.

2.2 REQUIRED MAINTENANCE EQUIPMENT

- A. Contractor's option, well maintained in first class condition, capable of successfully executing the work within the agreed time allotment. Deflectors or guards shall be in place and in good working order at all times.

PART 3 EXECUTIONS

3.1 GENERAL

- A. Duration: Continuously maintain all landscape areas after installation, during progress of work, and for a period of no less than one year after 90 day maintenance period.
- B. Protection:
 - Protect all newly planted areas from damage.
 - Establishment of newly installed material includes temporary protection fences, barriers and signs as required for protection.

- C. Replacements:

Immediately treat or replace all plants that become damaged or injured, as directed by Owner's Representative at no additional cost to Owner.

Replacement plants shall be of a size, condition and variety acceptable to Owner's Representative.

3.2 DEBRIS AND LITTER REMOVAL

- A. It shall be the responsibility of the Contractor to inspect the site twice weekly and remove all litter and debris accumulations in planting and paved areas.

3.3 SUPPLEMENTAL WATERING

- A. It shall be the responsibility of the Contractor to assure that the correct watering of plant materials is being accomplished through use of the irrigation system, hand-watering, 'gator' bags, water truck, etc.
- B. Contractor shall monitor settings of automatic sprinkler controls and make necessary adjustments according to climatic changes.
- C. Contractor shall not be responsible for supplemental watering areas that do not have irrigation systems, unless required by the Contract.
- D. Contractor shall be responsible for damages to irrigation system caused by mowing and other maintenance operations. Such damage will be repaired immediately at the Contractor's expense.

3.4 TREES, SHRUBS AND VINES

- A. Watering Basins:

- 1 Maintain all watering basins around plants so that enough water can be applied to establish moisture through major root zones.
 - 2 In rainy season, open basins to allow surface drainage away from the root crown where excess water may accumulate. Restore watering basins at end of rainy season.
 - 3 For supplemental hand watering of watering basins, use a water wand to break the water force. Do not permit crown roots to become exposed to air through dislodging of soil and mulch.
 - 4 Maintain originally called for depth of mulch to reduce evaporation and frequency of watering.
 - 5 Check for moisture penetration throughout the root zone at least once per week.
 - 6 To avoid root damage to young plants, minimize weed growth and protect any pre-emergent barriers, **cultivation of beds and tree wells will not be permitted.**
 - 7 Resetting: Reset plants to proper grades or upright position. Maintain staking and guying to insure plants remain upright.
- B. Weed Control:
1. Control weeds with hand removal or the use of legally approved herbicides by the Town of Addison Parks Department.
 2. All areas between plants, including watering basins, shall be weed free.
 3. Use only recommended and legally approved organic herbicides to control weed growth.
 4. **No soil cultivation will be permitted**
- C. Pruning:
- 1 Prune trees to select and develop permanent scaffold branches that are smaller in diameter than the trunk or branch to which they are attached, and which have vertical spacing of 18 in. to 48 in. and radial orientation so as not to overlay one another.
 - 2 Prune trees to eliminate diseased or damaged growth, and narrow V-shaped branch forks that lack strength. Reduce toppling and wind damage by thinning out crowns.
 - 3 Prune trees to maintain growth within space limitations, maintaining a natural appearance and balancing crown with roots.
 - 4 No stripping of lower branches ("raising up") of young trees will be permitted.
 - 5 Retain lower branches in a "tipped back" or pinched condition to promote caliper trunk growth (tapered trunk). Do not cut back to fewer than six buds or leaves on such branches. Only cut lower branches flush with the trunk after the tree is able to stand erect without staking or other support.
 - 6 Thin out and shape evergreen trees when necessary to prevent wind and storm damage. Do primary pruning of deciduous trees during the dormant season. Do not permit any pruning of trees prone to excessive "bleeding" during growth season.
 - 7 Prune damaged trees or those that constitute health or safety hazards at any time of year as required.
 - 8 Make all cuts clean and close to the trunk, without cutting into the branch collar. "Stubbing" will not be permitted. Cut smaller branches flush with trunk or lateral branch. Make larger cuts (1 in. in diameter or larger) parallel to shoulder rings, with the top edge of the cut at the trunk or lateral branch.
 - 9 Branches too heavy to handle shall be precut in three stages to prevent splitting or peeling of bark. Make the first two cuts 18 in. or more from the trunk to remove the branch. Make the third cut at the trunk to remove the resulting stub.
 - 10 Do not prune or clip shrubs into balled or boxed forms unless specifically called for by design. The use of hedge shears for the pruning of shrubs WILL NOT be allowed.
- D. Clip shrubs to be hedged when branches project 2 in. beyond limit of clipped hedge shown on the Drawings.

3.5 GROUNDCOVERS

A. Watering:

1. Check for moisture penetration throughout the root zone at least twice a month.
2. Water as frequently as necessary to maintain healthy growth of ground covers.

B. Weed Control:

- 1 All planting areas will be maintained in a healthy weed-free condition by the use of legally approved pre-and post-emergent organic herbicides or hand-pulling. No soil cultivation will be permitted. In the case of heavy compaction, spading folks shall be used to loosen the soil without damaging the roots on the plant material. In these cases, the bed will be raked smooth and re-mulched.
- 2 Minimize hoeing of weeds in order to avoid plant damage.
- 3 Use only recommended and legally approved organic herbicides to control weed growth.

3.6 LAWNS

A. Watering:

1. Water lawns at such frequency as weather conditions require, replenishing soil moisture to 6 in. below root zone.
2. Apply enough water to newly sodded areas to wet the soil to a depth of 2"-3" (approx. ¼ inch in clay soils). In established lawn areas, apply enough water to wet the soil to a depth of 6" (approx. ½ inch in clay soils). These application rates are suggestions only. The frequency and actual duration of watering cycles will vary according to weather, soil type, slopes, etc. The contractor will be solely responsible for providing the optimum watering schedule for the project. In sloped areas where runoff may be a problem, break each watering period into 3-4 shorter periods to allow better water absorption.
3. Watering shall be done during early mornings.

B. Weed Control:

- 1 All lawn areas will be maintained in a healthy weed-free condition by the use of legally approved pre-and post-emergent organic herbicides or hand-pulling.
- 2 In areas where crabgrass has infested the lawn, apply corn gluten meal within the seasonal parameters listed in Section 3.6.E.2
- 3 Use only recommended and legally approved organic herbicides to control weed growth. Do not irrigate for 48 hours after application of all herbicide sprays.

C. Mowing and Edging:

- 1 Mowing lawn/grass areas shall be accomplished with sharp, properly adjusted mowers of the correct size for the various areas
- 2 Mowing frequency shall be weekly. Blade heights shall be set according to the type of turf and weather conditions. Typically:
Bermudagrass: 1 inch St. Augustinegrass: 2-1/2 inches
Zoysia: 1 inch Ryegrass: 2 inches
- 1 Trim edges with each mowing or as required for neat appearance. Edging shall be performed with a blade type mechanical edger, shovel or herbicide. Line trimmers may only be used along walls and bed edges, not walks and curbs. Blow trimmings back into lawn area or collect and transfer to a designated compost area.
- 2 A grass free clear space (edge) two (2") inches in width shall outline all obstacles.

- D. In the event of a prolonged rainy period and a surge of leaf growth is anticipated, the mower height may be re-adjusted to prevent "scalping" or skinning of lawn on preceding cuts. Never remove more than 1/3 of the leaf growth in a single mowing.

E. Top Dress Fertilizer: Applied during the establishment period at 45 Days after turf installation

- 1 Preparation: Immediately prior to top-dress application, cut lawn and leave clippings.

2. Application: Per 1000 square feet, apply fertilizer at following schedules and rates: Product 40 Days 80 Days
 - *Corn Gluten Meal Early Spring and Late Fall 20lbs
 - Slow Release Fertilizer Mid Summer and Winter 20lbs
- *IMPORTANT: Corn Gluten Meal is a natural pre-emergent herbicide and fertilizer. DO NOT fertilize with Corn Gluten Meal if you will be seeding the area within 6 weeks of application. Use Slow Release Fertilizer approved by the Town of Addison if there is a conflict with a seeding or overseeding schedule and resume the above schedule during the next application. Thoroughly water in the gluten meal and allow to dry for 2 days immediately after application.
3. Reseeding of Lawn Areas: Match existing seed mix of adjacent areas.
 - a. Until the establishment of the turf, the Contractor will be responsible for replacing soils that have eroded onto the paved areas. Residual soils on paving will be removed and if not mingled with objectionable materials, may be re-used in eroded areas.
 - b. Immediately upon observing any lawn grass spreading into shrub or ground cover areas, the Contractor shall initiate a program of mechanical removal and maintain this program throughout the maintenance period.
 - c. Any lawn grass appearing in paved areas shall receive an application of or organic herbicides such as 25% acidic White Vinegar or Burn Out II® Weed and Grass Killer.
4. Special effort shall be given to the control of fire ants infesting the site. Use an organic product such as Garden-Ville brand Fire Ant Control. After control is accomplished, the ant mounds shall be lowered and tamped to the existing grade.

ANNUALS AND PERENNIALS

- A. Care for all seasonal color and perennial beds per established and horticultural practices. Failure to use horticultural practices may result in replacement of the plant material at the Contractor's expense.
- B. Weed Control: All planters with annuals and perennials shall be weed-free at all times.
- C. Pruning:
 - 1 Limit pruning to removal of damaged or dead twigs and foliage.
 - 2 Remove spent flowers on a weekly basis.
- D. Replacements of Annuals:
 - 1 Replace annuals when materials exhibit a "spent" condition.
 - 2 Thoroughly cultivate soil after removal of "spent" or "dead" plants prior to planting new materials.
 - 3 Incorporate slow release fertilizers and rake smooth.

3.8 INSECTS, PESTS, AND DISEASE CONTROL

- A. Contractor shall be continuously alert for signs of insect presence or damage or the presence or damage from plant fungi. The Contractor shall immediately take action to control to infestation. Plant material that is damaged or that dies from insect or disease infestation while under the Contractor's care shall be immediately replaced at the Contractor's expense.
- B. Inspection: Inspect all plant materials weekly for signs of stress, damage and potential trouble from the following:
 - 1 Presence of insects, moles, gophers, ground squirrels, snails and slugs in planting areas.
 - 2 Discolored or blotching leaves or needles.

- 3 Unusually light green or yellowish green color inconsistent with normal green color of leaves.
- C. Personnel: Application of pesticides or beneficial insect release for insect, pest and disease control shall be performed by a certified pesticide applicator.
- D. Application: Spray with extreme care to avoid all hazards to any person or pet in the area or adjacent areas. **Notify the Owner's Representative at least 48 hours in advance of any pesticide application.**

3.9 IRRIGATION SYSTEM

- A. General:
 - 1 Repair, without charge to Owner, all damages to system caused by Contractor's operations. Perform all repairs within 24 hours.
 - 2 Report promptly to Owner all accidental damage not resulting from Contractor's negligence or operations.
 - 3 Do not run the irrigation system during periods of rain. Set and program automatic controllers for seasonal water requirements.
 - 4 Twice a month, use a probe or other acceptable tool to check the rootball moisture of representative plants as well as the surrounding soil.
- B. Cleaning and Monitoring the System:
 - 1 Continually monitor the irrigation systems to verify that they are functioning properly as designed. Make program adjustments required by changing field conditions.
 - 2 If applicable, clean pump filter and strainer once a year and as often as necessary to keep the irrigation systems free of sand and other debris.
 3. Prevent spraying on windows, building walls, (game courts) by balancing the throttle control on the remote control valves and the adjustment screws on the sprinkler heads. Do not allow water to atomize and drift.

C. Winterization:

Normally, the irrigation system should be left operational during the winter. While the frequency may be as little as one cycle per month, the landscape will need supplemental water if winter rainfall is not adequate.

The irrigation system is designed to be completely drained to protect pipe from bursting prior to freezing temperatures. To adequately drain the system, the following procedure must be followed:

1. Air blow-out:
 - a. Set automatic control stations to 2-1/2 minutes timing.
 - b. Attach hose from portable air compressor to 1 in. air inlet installed on main line at backflow preventer.
 - c. Operate compressor at 100 cu. ft. per second at 60-80 PSI.
- 1 Manual drain valves: Open manual drain valves located at low points on the main line to drain main completely after air blow-out has been completed.
- 2 Backflow Preventer: Provide thermal insulation (heat tape) to protect vacuum barrier during the winter. Rotate backflow unit at unions and open pet cocks and drain. Reverse operation and tighten unions to resume irrigation.

3.10 OWNER ACCEPTANCE

- A. Acceptance:
 - 1 Work will be accepted by the Owner's Representative upon satisfactory completion of all work,

- but exclusive of replacement of materials under the Warranty Period.
- 2 Submit a written request to Owner's Representative for review for Final Acceptance at least five (5) working days prior to anticipated Final Review date.

B. Corrective Work:

- 1 Work requiring corrective action or replacement in the judgment of the Owner's Representative shall be performed within ten (10) calendar days after the review.
- 2 Corrective work and materials replacement shall be performed in accordance with the original Drawings and Specifications, and shall be made by the Contractor at no cost to the Owner.

3.11 CLEAN-UP

- A. All areas shall be kept neat and orderly at all times. Debris from maintenance operations shall be gathered and shall not be allowed to remain in place in excess of two (2) hours. Remove all such debris from the site at the end of each day.

END OF SECTION

SECTION 32 91 19
LANDSCAPE GRADING

PART 1 GENERAL

1.1 SECTION INCLUDES

- A. Filling, backfilling, and compacting for footings, slabs-on-grade, paving, and site structures.
- B. Backfilling and compacting for utilities outside the building to utility main connections.
- C. Filling holes, pits, and excavations generated as a result of removal (demolition) operations.

1.2 RELATED SECTIONS

- A. Section 32 92 23 – Sodding
- B. Section 32 93 00 – Landscape Planting.

1.3 REFERENCES

- A. AASHTO T 180 - Standard Specification for Moisture-Density Relations of Soils Using a 4.54 kg (10-lb) Rammer and a 457 mm (18 in.) Drop; American Association of State Highway and Transportation Officials; 2001.
- B. ASTM C 136 - Standard Test Method for Sieve Analysis of Fine and Coarse Aggregates; 2001.
- C. ASTM D 698 - Standard Test Methods for Laboratory Compaction Characteristics of Soil Using Standard Effort (12,400 ft-lbf/ft³ (600 kN-m/m³)); 2000a.
- D. ASTM D 1556 - Standard Test Method for Density and Unit Weight of Soil in Place by the Sand-Cone Method; 2000.
- E. ASTM D 1557 - Standard Test Methods for Laboratory Compaction Characteristics of Soil Using Modified Effort (56,000 ft-lbf/ft³ (2,700 kN m/m³)); 2002.
- F. ASTM D 2167 - Standard Test Method for Density and Unit Weight of Soil in Place by the Rubber Balloon Method; 1994(R 2001).
- G. ASTM D 2487 - Standard Practice for Classification of Soils for Engineering Purposes (Unified Soil Classification System); 2000.
- H. ASTM D 2922 - Standard Test Methods for Density of Soil and Soil-Aggregate in Place by Nuclear Methods (Shallow Depth); 2001.

- I. ASTM D 3017 - Standard Test Method for Water Content of Soil and Rock in Place by Nuclear Methods (Shallow Depth); 2001.

1.4 DEFINITIONS

- A. Finish Grade Elevations: Indicated on drawings.
- B. Subgrade Elevations: Will be left 6 inches below finish grade elevations in lawn and seeded areas, as indicated on drawings; and 6 inches below finish grade in planting areas, as indicated on drawings, unless otherwise indicated.

1.5 SUBMITTALS

- A. See Section 01330 Submittal Procedures.
- B. Fill Composition Test Reports: Results of laboratory tests on proposed and actual materials used.
- C. Compaction Density Test Reports.

1.6 PROJECT CONDITIONS

- A. Provide sufficient quantities of fill to meet project schedule and requirements. When necessary, store materials on site in advance of need.
- B. When fill materials need to be stored on site, locate stockpiles where indicated.
 - 1. Separate differing materials with dividers or stockpile separately to prevent intermixing.
 - 2. Prevent contamination.
 - 3. Protect stockpiles from erosion and deterioration of materials.
- C. Verify that survey bench marks and intended elevations for the Work are as indicated.

PART 2 PRODUCTS

2.1 FILL MATERIALS

- A. General Fill: Subsoil excavated on-site (Provide borrow soil materials when sufficient satisfactory soils materials are not available from excavations).
 - 1. Graded.
 - 2. Free of lumps larger than 3 inches, rocks larger than 2 inches, and debris.
 - 3. Conforming to ASTM D 2487 Group Symbol CL.
- B. Granular Fill: Coarse aggregate, conforming to State of Texas Highway Department standard.
- C. Sand: Natural river or bank sand; washed; free of silt, clay, loam, friable or soluble materials, and organic matter.
 - 1. Grade in accordance with ASTM D 2487 Group Symbol SW.
- D. Topsoil: Dark brown friable loamy topsoil, screened to remove rocks, clay lumps, clods, vegetative material.

2.2 ACCESSORIES

- A. Geotextile Fabric: Non-biodegradable, woven.
- B. Vapor Retarder: 10 mil thick, polyethylene.

2.3 SOURCE QUALITY CONTROL

- A. See 01400 Quality Assurance, for general requirements for testing and analysis of soil material.
- B. Where fill materials are specified by reference to a specific standard, test and analyze samples for compliance before delivery to site.
- C. If tests indicate materials do not meet specified requirements, change material and retest.
- D. Provide materials of each type from same source throughout the Work.

PART 3 EXECUTION

3.1 EXAMINATION

- A. Identify required lines, levels, contours, and datum locations.
- B. Verify subdrainage, dampproofing, or waterproofing installation has been inspected.
- C. Verify structural ability of unsupported walls to support imposed loads by the fill.

3.2 PREPARATION

- A. Protect structures, utilities, sidewalks, pavements, and other facilities from damage caused by Work.
- B. Protect subgrades and foundation soils against freezing temperatures or frost. Provide protective insulating materials as necessary.
- C. Provide erosion-control measures to prevent erosion or displacement of soils and discharge of soil-bearing water runoff or airborne dust to adjacent properties and walkways.
- D. Reconstruct subgrades damaged by freezing temperatures, frost, rain, accumulated water, or construction activities, as directed by Landscape Architect.
- E. Scarify and proof roll subgrade surface to a depth of 6 inches to identify soft spots.
- F. Cut out soft areas of subgrade not capable of compaction in place. Backfill with general fill.
- G. Compact subgrade to density equal to or greater than requirements for subsequent fill material.
- H. Until ready to fill, maintain excavations and prevent loose soil from falling into

excavation.

3.3 UNWATERING

- A. Prevent surface water and ground water from entering excavations, from ponding on prepared subgrades, and from flooding Project site and surrounding area.
- B. Protect subgrades from softening, undermining, washout, and damage by rain or water accumulation.
 - Reroute surface water runoff away from excavated areas. Do not allow water to accumulate in excavations. Do not use excavated trenches as temporary drainage ditches.
 - Install an unwatering system to keep subgrades dry and convey ground water away from excavations. Maintain until unwatering is no longer required.

3.4 FILLING

- A. Place and compact backfill in excavations promptly, but not before completing the following:
 - 1. Construction below finish grade including, where applicable, damproofing, waterproofing, and perimeter insulation.
 - 2. Surveying locations of underground utilities and record documents.
 - 3. Inspecting and testing underground utilities.
 - 4. Removing trash and debris.
 - 5. Removing vegetation, topsoil, unsatisfactory soil materials, obstructions, and deleterious materials.
 - 6. Removing concrete formwork.
 - 7. Removing temporary shoring and bracing and sheeting.
 - 8. Installing permanent or temporary horizontal bracing on horizontally supported walls.
- B. Fill to contours and elevations indicated using unfrozen materials.
- C. Employ a placement method that does not disturb or damage other work.
- D. Systematically fill to allow maximum time for natural settlement. Do not fill over porous, wet, frozen or spongy subgrade surfaces.
- E. Maintain optimum moisture content of fill materials to attain required compaction density.
- F. Granular Fill: Place and compact materials in equal continuous layers not exceeding 6 inches compacted depth.
- G. Soil Fill: Place and compact material in equal continuous layers not exceeding 8 inches compacted depth.
- H. Slope grade away from building minimum 2 inches in 10 ft, unless noted otherwise. Make gradual grade changes. Blend slope into level areas.
- I. Correct areas that are over-excavated.

1. Load-bearing foundation surfaces: Use structural fill, flush to required elevation, compacted to 100 percent of maximum dry density.
 2. Other areas: Use general fill, flush to required elevation, compacted to minimum 97 percent of maximum dry density.
- I. Compaction Density Unless Otherwise Specified or Indicated:
1. Under paving, slabs-on-grade, and similar construction: 95 percent of maximum dry density.
- J. Reshape and re-compact fills subjected to vehicular traffic.

3.5 FILL AT SPECIFIC LOCATIONS

- A. Use general fill unless otherwise specified or indicated.
- B. At Foundation Walls and Footings:
1. Use Structural Fill.
 2. Fill up to subgrade elevation.
 3. Compact each lift to 95 percent of maximum dry density.
 4. Do not backfill against unsupported foundation walls.
 5. Backfill simultaneously on each side of unsupported foundation walls until supports are in place.
- C. Over Subdrainage Piping at Foundation Perimeter and Under Slabs:
1. Cover drainage fill with general fill.
 2. Fill up to subgrade elevation.
 3. Compact to 95 percent of maximum dry density.
- D. Over Buried Utility Piping and Conduits in Trenches:
1. Bedding: Use granular fill.
 2. Cover with general fill.
 3. Fill up to subgrade elevation.
 4. Compact in maximum 8 inch lifts to 95 percent of maximum dry density.
- E. At Lawn Areas:
1. Use general fill.
 2. Fill up to subgrade elevations.
 3. Compact to 85 percent of maximum dry density.
 4. See Section 32 93 00 – Landscape Planting for topsoil placement.
- F. At Planting Areas Other Than Lawns:
1. Use general fill.
 2. Fill up to subgrade elevations.
 3. Compact to 85 percent of maximum dry density.
 4. See Section 32 93 00 – Landscape Planting for topsoil placement.

3.6 MOISTURE CONTROL

- A. Uniformly moisten or aerate subgrade and each subsequent fill or backfill layer before compaction to within 2 percent of optimum moisture content.

- Do not place backfill or fill material on surfaces that are muddy, frozen, or contain frost or ice.
- Remove and replace, or scarify and air-dry, otherwise satisfactory soil material that exceeds optimum moisture content by 2 percent and is too wet to compact to specified dry unit weight

3.7 COMPACTION OF BACKFILLS AND FILLS

- A. Place backfill and fill materials in layers not more than 8 inches (200 mm) in loose depth for material compacted by heavy compaction equipment, and not more than 4 inches (100 mm) in loose depth for material compacted by hand-operated tampers.
- B. Place backfill and fill materials evenly on all sides of structures to required elevations, and uniformly along the full length of each structure.
- C. Compact soil to not less than the following percentages of maximum dry unit weight according to ASTM D 698:
 - 1. Under structures, foundations, footings, building slabs, steps, and pavements, scarify and recompact top 12 inches (300 mm) of existing subgrade and each layer of backfill or fill material at 95 percent.
 - 2. Under walkways, scarify and recompact top 6 inches (150 mm) below subgrade and compact each layer of backfill or fill material at 92 percent.
 - 3. Under lawn or unpaved areas, scarify and recompact top 6 inches (150 mm) below subgrade and compact each layer of backfill or fill material at 85 percent.

3.8 TOLERANCES

- A. Top Surface of General Filling: Plus or minus 1 inch from required elevations.

3.9 FIELD QUALITY CONTROL

- A. See Section 01400 - Quality Control, for general requirements for field inspection and testing.
- B. Perform compaction density testing on compacted fill in accordance with ASTM D1556, ASTM D2167, ASTM D2922, or ASTM D3017.
- C. Evaluate results in relation to compaction curve determined by testing uncompacted material in accordance with ASTM D 698 ("standard Proctor"), ASTM D 1557 ("modified Proctor"), or AASHTO T 180.
- D. If tests indicate work does not meet specified requirements, remove work, replace and retest.
- E. Proof roll compacted fill at surfaces that will be under slabs-on-grade.

3.10 CLEAN-UP

- A. Remove unused stockpiled materials, leave area in a clean and neat condition. Grade stockpile area to prevent standing surface water.

- B. Leave borrow areas in a clean and neat condition. Grade to prevent standing surface water.

END OF SECTION

SECTION 32 92 23

SODDING

PART 1 GENERAL

1.1 SECTION INCLUDES

- A. Preparation of subsoil.
- B. Sod installation.

1.2 RELATED SECTIONS

- A. Section 32 93 00 – Landscape Planting

1.3 REFERENCES

- A. TPI (SPEC) -Guideline Specifications to Turfgrass Sodding; Turfgrass Producers International; 1995.

1.4 SUBMITTALS

- A. See Section 01330 Submittal Procedures
- B. Certification: Submit certification of grass species and location of sod source.

1.5 QUALITY ASSURANCE

- A. Sod Producer: Company specializing in sod production and harvesting with minimum five years experience and certified by the State of Texas.
- B. Installer Qualifications: Company approved by the sod producer.

1.6 DELIVERY, STORAGE, AND HANDLING

- A. Deliver sod on pallets. Protect exposed roots from dehydration.
- B. Do not deliver more sod than can be laid within 24 hours.

1.7 INSPECTIONS

- A. Make written request for inspection of finish grade prior to sodding.
- B. Make written request for inspection that sodding operations have been completed. Such inspection is for the purpose of establishing the Maintenance Period.
- C. Submit written requests for inspections to the Landscape Architect at least seven (7) days prior to anticipated inspection date.

1.8 WARRANTY PERIOD

- A. Time Period: Warrant that all lawns and grasses shall be in a healthy and flourishing condition of active growth six (6) months from date of Final Acceptance.
- B. Appearance During Warranty: Lawns shall be free of dead or dying patches, and all areas shall show foliage of a normal density, size and color. Complete lush cover with no brown sections or cracks showing.
- C. Delays: All delays in completion of planting operations which extend the planting into more than one planting season shall extend the Warranty Period correspondingly.
- D. Exceptions: Contractor shall not be held responsible for failures due to neglect by Owner, vandalism, etc., during Warranty Period. Report such conditions in writing.
- E. Replacements: Replace, without cost to Owner, and as soon as weather conditions permit, all lawn and grasses not in a vigorous, thriving condition, as determined by Landscape Architect during and at the end of Warranty Period.
- F. Matching: Closely match all replacement sod with adjacent areas of lawn or grass. Apply all requirements of this Specification to all replacements

1.9 FINAL ACCEPTANCE

- A. Work under this Section will be accepted by Landscape Architect upon satisfactory completion of all work, but exclusive of re-application under the Guarantee Period.

PART 2 PRODUCTS

2.1 MATERIALS

- A. Sod: TPI, Certified Turfgrass Sod quality; cultivated grass sod; type indicated in plant schedule on Drawings; with strong fibrous root system, free of stones, burned or bare spots, relatively free of thatch; free from diseases and harmful insects; containing no more than 5 grassy and/or broadleaf weeds per 1000 sq ft; . Minimum age of 18 months, with root development that will support its own weight without tearing, when suspended vertically by holding the upper two corners.
- B. Sod shall be rejected if found to contain the following weeds: Quackgrass, johnsongrass, poison ivy, nimbleweed, thistle, bindweed, bentgrass, perennial sorrel, bromegrass.
- C. Topsoil: As specified in Section 32 93 00 – Landscape Planting.

2.2 ACCESSORIES

- A. Wood Pegs: Softwood, sufficient size and length to ensure anchorage of sod on slope.
- B. Wire Mesh: Interwoven hexagonal metal wire mesh of 2 inch size.

2.3 HARVESTING SOD

- A. Machine cut sod in accordance with TPI Guidelines.
- B. Cut sod in area not exceeding 1 sq yd, with minimum 1/2 inch and maximum 1 inch topsoil base.

PART 3 EXECUTION

3.1 SOD BED PREPARATION

- A. Prepare subgrade in accordance with Section 32 93 00 – Landscape Planting.
- B. Final Grading
 - 1. Stones, Weeds, Debris: Verify that all areas to receive lawns are clear of stones larger than 1-1/2 in. diameter, weeds, debris and other extraneous materials.
 - 2. Grades: Verify that grades are within 1 in. plus or minus of the required finished grades. Verify that soil preparation and fertilization has been installed in another section. Report all variations in writing.
 - 3. Rake areas to set exact line and final finish grade.
- C. Rolling: Roll amended soil with 200 pound water-ballast roller.
- D. Soil Moisture:
 - 1. Excessive Moisture: Do not commence work of this section when soil moisture content is so great that excessive compaction will occur, nor when it is so dry that dust will form in air or that clods will not break readily.
 - 2. Inadequate Moisture: Apply water, as necessary, to bring soil to an optimum moisture content for planting, immediately prior to laying the sod.
- E. Timing: Sod immediately thereafter, provided the sod-bed has remained friable.

3.2 LAYING SOD

- A. Moisten prepared surface immediately prior to laying sod.
- B. Lay sod within 24 hours after harvesting. Sod over 24 hour old will be removed from the site immediately.
- C. Lay the first row of sod in a straight line, with subsequent rows parallel to and set tight with no open joints visible, and no overlapping; stagger lateral joints 12 inches minimum. Do not stretch or overlap sod pieces.
- D. Lay smooth.
- E. Cut sod to fit curves with a sharp knife.
- F. Place top elevation of sod 1/2 inch below adjoining edging.
- G. On berms and slopes lay sod with strips parallel to contours.
- H. On slopes four inches per foot and steeper, lay sod perpendicular to slope and secure every row with wooden pegs at maximum 1 1/2 feet on center. Drive pegs flush with soil portion of sod.

- I. Water sodded areas immediately after installation. Saturate sod to 6 inches of soil.
- J. After sod and soil have dried, roll sodded areas to ensure good bond between sod and soil and to remove minor depressions and irregularities. Roll sodded areas with roller not exceeding 200 lbs.
- K. Immediately after installation of the sod, remove sod clumps and soil, wash off any plant materials and pavements not to have sod. Keep all areas clean during the maintenance period.

3.3 CLEAN-UP

- A. General: Keep all areas of work clean, neat and orderly at all times. Keep all paved areas clean during planting operations.
- B. Debris: Clean up and remove all deleterious materials and debris from the entire work area prior to Final Acceptance.

END OF SECTION

SECTION 32 93 00
LANDSCAPE PLANTING

PART 1 GENERAL

1.1 SECTION INCLUDES

- A. Preparation of subsoil.
- B. Excavation of plant pits and beds.
- C. Backfill planting pits and bed preparation.
- D. Installation of new plant material.
- E. Finish grading of planting areas.
- F. Mulch and Fertilizer.
- G. Installation of Steel Edging.
- H. Maintenance.
- I. Tree Pruning.
- J. Warranty and Replacements

1.2 RELATED SECTIONS

- A. Section 32 92 23 – Sodding
- B. Section 32 01 90 – 90 Day Establishment Planting

1.3 REFERENCES

- A. ANSI Z60.1 -American Standard for Nursery Stock; 2004.
- B. ANSI A300 -American National Standard for Tree Care Operations --Tree, Shrub and Other Woody Plant Maintenance --Standard Practices; 2006.

1.4 DEFINITIONS

- A. Weeds: Any plant life not specified or scheduled.
- B. Plants: Living trees, plants, and ground cover specified in this Section.

1.5 SUBMITTALS

- A. See Section 01330 Submittal Procedures

- B. Provide the following Material Samples and Literature:
1. Photographic image of each variety and size of plant material shown on the plans and plant list and indicated in the specifications. Each image will include a clearly legible measuring device, plant common name, plant botanical name, and the supplier's name, location and phone number. Submit representative photographs for review of all plant materials in the required sizes and in available quantity at least ninety (90) working days prior to shipment to the site.
 2. Hardwood Mulch: One (1) gallon (sample) with analysis and literature including supplier's name, location and phone number.
 3. Soil Amendments: One (1) gallon (sample) with analysis and literature including supplier's name, location and phone number.
 4. Tree Staking/Guying: Literature for materials and shop drawings of installation details and procedures.
 5. Plant Material Supplier: Ordering Document, Order Confirmation. Submit documentation within thirty (30) days after Award of Contract that all plant materials have been located and are ready to be secured. Arrange specific review and/or tagging procedure of plant materials at time of submission.
 6. Shipping and Transportation Plan for distant material. The plan shall include:
 - Date of pick-up at nursery or place of storage.
 - Type of vehicle used for shipping.
 - Method of protecting trees during transit.
 - Dates in transit.
 - Date of delivery to site.
 - Projected date of installation.
 - Means of storage, watering and protection to be used between deliveries and installation.
 7. Shop Drawings: Supply shop drawings for all items associated with the landscape installation including, but not limited to; staking and guying details, tree protection fencing, steel edging installation, gravel paving, planter installation and drainage, landscape drain installation, etc.
- C. Submittal Schedule: All products in this section which are required for submittal shall be included in one (1) submittal package.

1.6 QUALITY ASSURANCE

- A. Quality Control: Plant material shall be subject to inspection and approval by Landscape Architect at place of growth or storage and upon delivery for conformity to specifications.
- B. Samples: The Owner reserves the right to request samples of materials for conformity to specifications at any time, including plants. Contractor shall furnish samples upon request. Rejected materials shall be immediately removed from the site at Contractor's expense. Cost of samples of materials not meeting specifications shall be paid by Contractor.
- C. Nursery Qualifications: Company specializing in growing and cultivating the plants with three years documented experience.
- D. Installer Qualifications: Company with a minimum of five years of experience in the installation of commercial landscaping and site construction.

- E. Tree Care Qualifications: Firm specializing in the pruning and care of trees. All work will be performed or directly supervised by a certified arborist. All work will be performed according to TCIA – Pruning Standards for Shade Trees. If the installation contractor does not employ a certified arborist, the work shall be subcontracted to a firm that meets the qualifications.
- F. Maintenance Services: Performed by qualified professional maintenance contractor. All pesticide applications will be done by an applicator certified by the Texas Department of Agriculture or the Structural Pest Control Board. If the installation contractor does not employ a certified pesticide applicator or licensed irrigator, the work shall be sub-contracted to a firm that meets the qualifications.

1.7 TAGGING

- A. Nursery review and plant selections: The Landscape Architect may elect to review any of the material at the place of growth. Upon review and acceptance of plant material photograph, specific items will be selected for field review by the Landscape Architect. The Landscape Contractor shall arrange the review and accompany the Landscape Architect for all reviews and tagging at place of growth, and upon delivery, for conformity to the specifications. Contractor shall insure a sufficient quantity of plants will be available whenever trips are arranged to a nursery for the purposes of tagging material for the project.
- B. Plants identified as “specimen” or "selected specimen" shall be approved and tagged at place of growth by Landscape Architect. For distant material, submit photographs with a clearly legible measuring device adjacent to plants for preliminary review. Such review shall not impair the right of review and rejection during progress of the work.
- C. Contractor is responsible for all travel related expenses for tagging trips necessary to select and procure material. Owner and Landscape Architect will accompany contractor, but travel expense for these individuals are not included in contractor’s scope of work.
- D. All plants inspected at the nursery by the Landscape Architect shall be tagged with serialized self-locking tags. Trees delivered to the site without these tags or with broken tags shall be sufficient reason for rejection.

1.8 PHOTOGRAPHIC ACCEPTANCE

- A. Photograph Acceptance and Nursery Review: Acceptance of material through photographs does not preclude rejection of unsatisfactory material upon delivery. The Landscape Architect reserves the right to refuse review from photographs or at the grower if, in his judgment suitable material or sufficient quantities are not available.

1.9 SUBSTITUTIONS

- A. Unavailable Material: If any plant material is not available, the Contractor shall bring this to the attention of the Landscape Architect at least 3 days prior to the bid due date. If there is no notice of the lack of availability, it will be assumed that the Contractor has located sources for all materials required to complete the work. If proof is submitted that any plant specified is not obtainable, a proposal will be considered for use of the nearest

equivalent size or variety with corresponding adjustment of Contract price. Substantiate such proof in writing no later than fifteen (15) days after award of contract.

Prior to selecting alternate material, the Landscape Architect may, at his discretion, attempt to locate the material. Should the specified plant material be located by the Landscape Architect for the Contractor, the Contractor shall secure the material from the new source at no change to the contract price.

- B. Substitutions of plant materials will not be permitted unless authorized in writing by Landscape Architect. If proof is submitted that any plant specified is not obtainable, a proposal will be considered for use of the nearest equivalent size or variety with corresponding adjustment of Contract Price. Such proof shall be substantiated and submitted in writing to Landscape Architect no later than fifteen (15) days after award of contract. These provisions shall not relieve Contractor of the responsibility of obtaining specified materials in advance if special growing conditions or other arrangements must be made in order to supply specified materials.

Prior to selecting alternate material, the Landscape Architect may, at his discretion, attempt to locate the material. Should the specified plant material be located by the Landscape Architect for the Contractor, the Contractor shall secure the material from the new source at no change to the contract price.

1.10 REGULATORY REQUIREMENTS

- A. Fertilizers, pesticides and other chemicals and materials required for the completion of the Work shall fully comply with city, county, state and federal regulatory agencies' requirements.
- B. Plant Materials: Described by ANSI Z60.1; free of disease or hazardous insects.

1.11 DELIVERY, STORAGE, AND HANDLING

- A. Deliver fertilizers, pesticides and other chemicals or materials in the manufacturer's original container. All labeling shall be attached and legible. Dry materials, such as fertilizer, will be delivered in waterproof bags showing weight, chemical analysis, and name of manufacturer.
- B. Labeling: All fertilizers, pesticides and other chemicals or materials shall include all of the manufacturer's original labeling legibly showing quantity, analysis and name of manufacturer. Representative samples of all varieties of plant material required will be tagged with labeling showing the botanical name, common name, size and grower. Material delivered to the site without this labeling is subject to rejection. Rejected material will be removed for the site and replaced at the Contractor's expense.
- C. Storage: Store products with protection from weather or other conditions which would damage or impair the effectiveness of the product. Protect plant containers from sun during summer months with temperatures above 80 degrees F. During hot weather the Contractor shall transport plant materials subject to heat damage between sunset and sunrise if transported in an open trailer or un-refrigerated box.
- D. Loading and Moving: Do not lift or handle plants by tops, stems or trunks at any

time. Do not bind or handle plants with any material or in any manner that could damage or disfigure the plant material at any time.

- 1 Protect all trunks, stems, branches and root balls during tree tying, wrapping and loading operations.
 - 2 Load balls or containers onto transport vehicle and secure in a manner that protects the structural integrity of the root balls.
 - 3 The Contractor shall be solely responsible for the safe transportation of plants to the site and their condition upon arrival. Trees damaged or dehydrated during transit and/or storage will be rejected.
 - 4 No trees are to be shipped and left in trailers or on trucks for storage. Arrange delivery so that the plant materials are shipped, off loaded, and safely stored or planted allowing the appropriate time from shipment to arrival with no delay. Balled and burlapped trees that are not planted the day of delivery shall be set upright and healed in with mulch until they are installed.
 - 5 The Landscape Architect may inspect any phase of this operation and may reject any plant material improperly handled during any phase of this operation.
- E. Anti-Desiccant: At Contractor's option, spray all evergreen or deciduous plant material in full leaf immediately before transporting with anti-desiccant. Apply an adequate film over trunks, branches, twigs and foliage.
- F. This Section shall not be interpreted as relieving the Contractor of the responsibility of providing healthy, viable plants, nor shall it have any affect upon the terms of the warranty specified herein.

1.12 ENVIRONMENTAL REQUIREMENTS

- A. Do not install plant material when ambient temperatures may drop below 32 degrees F for more than 24 hours. Do not install plant material when temperatures over 100 degrees F without written direction from the Landscape Architect or Owner's Representative.
- B. Do not install plant material when wind velocity exceeds 30 mph.

1.13 ESTABLISHMENT PERIOD AND FINAL ACCEPTANCE

- A. See Section 32 01 90 – Landscape Maintenance until Final Acceptance & Landscape Establishment for Ninety (90) Days (if applicable)
- B. Final acceptance of the Work will mark the beginning of the ninety-day landscape establishment period.

1.14 FINAL ACCEPTANCE

- A. Work under this Section will be conditionally accepted by Landscape Architect upon satisfactory completion of all work and punch-list corrections, but exclusive landscape establishment period or replacement of plant materials under the Warranty Period. The Contractor is responsible for all maintenance of the work until Final Acceptance, and the during the ninety-day establishment period. Upon completion of the landscape establishment period, the Owner will assume responsibility for maintenance of the Work.

1.15 WARRANTY

- A. **Warranty:** Warrant that all trees, shrubs, ground covers, and vines planted under this Contract will be healthy and in flourishing condition of active growth one (1) year from date of Final Acceptance. The Contractor shall be responsible for monitoring the condition of the landscape during the warranty period and for reporting any problems, in writing, to the Owner's Representative. Failure to report problems in a timely manner may make the Contractor responsible for the replacement of material damage from improper maintenance.
- B. **Delays:** All delays in completion of planting operations which extend the planting into more than one planting season shall extend the Warranty Period correspondingly. Delays due to water restrictions may extend the warranty period. Requests for changes to the warranty period will be made in writing to the Owner's Representative.
- C. **Condition of Plants:** Plants shall be free of dead or dying branches and branch tips, with all foliage of a normal density, size and color.
- D. **Replace,** without cost to Owner and as soon as weather conditions permit, all dead plants and all plants not in vigorous, thriving condition, as determined by the Owner or Owner's Representative during and at the end of Warranty Period. Plants shall be free of dead or dying branches and branch tips, and shall bear foliage of a normal density, size and color. Replacements shall meet the specifications of the original plant material, and closely match adjacent specimens of the same variety.
- E. **Replacement Quantities:**
 - 1 A new Warranty shall commence on date of replacement.
 - 2 Contractor shall be held responsible for as many replacements as necessary throughout the Warranty Period. The Contractor may ask for an alternate plant material in problem locations. The alternate plant material will be installed under the original warranty.
- F. Contractor shall not be held responsible for failure due to neglect by the Owner, vandalism, etc., during Warranty Period. Report such conditions to the Landscape Architect in writing.

PART 2 - PRODUCTS

2.1 TREES, PLANTS, VINES AND GROUND COVER

- A. **Trees, Plants, and Ground Cover:** Species and size identifiable in Plant Schedule in drawings.
- B. Unless otherwise noted in the specifications or plant list, all plants shall be nursery grown in accordance with good horticultural practices under climatic conditions similar to those of project for at least two years unless specifically otherwise authorized by Landscape Architect in writing. Unless specifically noted otherwise, all plants shall be exceptionally heavy, symmetrical, tightly knit, so trained or favored in development and appearance as to be superior in form, number of branches, compactness and symmetry.
- C. Plants shall be sound, healthy and vigorous, well branched and densely foliated when in

leaf. They shall be free of disease, insect pests, eggs, or larvae, and shall have healthy, well developed root systems. They shall be free from physical damage or adverse conditions that would prevent thriving growth.

- D. Container grown native grasses and aquatics (non-woody plants) shall have well-established root balls. Root balls of non-woody plants must not be separated, broken up, or otherwise damage prior to or during installation.
- E. Plants shall be true to species and variety and shall conform to measurements specified except that plants larger than specified may be used if approved by Landscape Architect. Use of such plants shall not increase Contract price. If larger plants are approved, the ball of earth or container size shall be increased as specified under "Applicable Standards" and subject to the approval of the Landscape Architect.
- F. Plants shall be measured when branches are in their normal position. Height and spread dimensions specified refer to main body of plant and not branch tip to tip. Trunk diameter measurements shall be taken at a point on the trunk six (6") inches above natural ground line for trees four (4") inches in diameter and smaller, and at a point twelve (12") inches above the natural ground line for trees larger than four (4") inches in diameter. Diameter measurements shall be taken using a diameter tape, not calipers.

The measurements specified are the minimum size acceptable and are the measurements after pruning, where pruning is required. Plants that meet the measurements specified, but do not possess a normal balance between height and spread shall be rejected.

- G. Container stock, when specified, shall be healthy, vigorous, well rooted, and established in the container in which it is growing. Container grown nursery stock shall have a well-established root system reaching the sides of the container to maintain a firm root ball when the container is removed, but shall not have excessive root growth encircling the inside of the container. Samples must prove no root-bound conditions exist. Container plants that have cracked or broken balls of earth when taken from container shall be rejected. Container stock shall not be pruned before delivery. Field grown plants recently transplanted into containers will not be accepted. Unless specified as 'containerized', no balled and burlap trees transplanted into containers will be accepted.
- H. Trees which have damaged, crooked or multiple leaders, unless specified, will be rejected. Trees with abrasions of the bark, sunscalds, disfiguring knots, or fresh cuts of limbs over three-quarter (3/4") inch which have not completely calloused, will be rejected.
- I. Balled and burlap (B&B) trees, when accepted shall have a minimum root ball size of ten (10x) times the diameter.
- J. Nursery grown B&B material shall be pruned and thinned at the place of growth immediately prior to digging as required for packaging and safe moving. Trees that are over-pruned or misshapen due to improper pruning will be rejected. Method of pruning shall be as approved in the field by the Landscape Architect. Do not remove self-locking tags during this pruning prior to delivery to site.
- K. Field collected or plantation grown stock shall conform to the applicable standards.

2.2 ANTI-TRANSPIRANT

- A. Anti-transpirant for retarding excessive loss of plant moisture and inhibiting wilt shall be sprayable, water insoluble polymer complex which will produce a moisture retarding barrier not removable by rain.
- B. WILT PRUF as manufactured by Wilt Pruf Products, Inc., Essex CT; or accepted equal.

2.3 SOIL MATERIALS

- A. Topsoil: Type specified in Section 32 91 19
- B. Soil Amendment Materials
 - 1. Pre-Plant Fertilizer: Containing fifty percent of the elements derived from organic sources; of proportion necessary to eliminate any deficiencies of topsoil, as indicated in analysis.
 - 2. Compost: Completely organic, aerobically composted humus product containing manure, wheat straw, plant matter, hardwood shavings and other organic components consisting of 80% vegetative material and 20% manure. Completely composted; free of weeds, weed seeds, insects, and pests. pH range 6.5-7.0 Supplied by Living Earth Technology, 972-869-9498
 - 3. Professional Bedding Soil: Bedding mix shall consist of compost and expanded shale. Gumbo Buster supplied by Soil Building Systems or equal can be substituted. (50% Shale and 50% Planting Bedding Mix)
 - 4. Top-dress Fertilizer: Per Organic Maintenance Specification
 - 5. Tree and Shrub Planting Fertilizer: Per Organic Maintenance Specification.
 - 6. Water: Clean, fresh, and free of substances or matter which could inhibit vigorous growth of plants. Watering for chemical tanks will not be allowed.
 - 7. Herbicide: For pre-plant preparation, Reference Organic Maintenance Specification. For post-plant weed control, Reference Organic Maintenance Specification. Applications must be approved for use in the State of Texas and be applied by licensed applicators. The Owner and/or Owners' Representative must be notified at least 48 in advance of applications. A copy of the applicator's log must be supplied to the Owner's Representative within 48 of any chemical application.
 - 8. Pesticide: Pesticides may be used for specific pest infestations, but only in limited application. Reference Organic Maintenance Specification. Applications must be approved for use in the State of Texas and be applied by licensed applicators. The Owner and/or Owners' Representative must be notified at least 48 in advance of pesticide applications. A copy of the applicator's log must be supplied to the Owner's Representative within 48 of any chemical application.

2.4 MULCH MATERIALS

- A. Mulching Material: Fine-ground shredded hardwood bark mulch – Double-ground, partially composted, and free of growth or germination inhibiting ingredients. pH range 6.0-7.0 Supplied by Living Earth Technology, 972-869-4332

2.5 ACCESSORIES

- A. Plant Staking Materials: Contractor shall use staking materials as necessary to meet the

requirements of the specification, subject to approval. Refer to details for staking and/or guying requirements.

1. Tree Stakes: 1.25# studded metal T-Posts -6' long.
 2. Wire: High-tensile 12 gauge; 200,000 psi; Class III zinc coating. Refer to details.
 3. Cable: 3/16" galvanized or stainless steel aircraft cable; 7x19; min. 4,200 psi break strength; secured with drop-forged galvanized clips
 4. Turnbuckles: Minimum 1/2"x6", hot-dipped galvanized or stainless steel, eye and eye.
 5. Ground Anchors: 30"x4" dia. galvanized ground screw for 3"-4" diameter trees, 48"x6" dia. for trees 5"-6" diameter.
 6. Plant Protectors: Reinforced black rubber hose sleeves over cable to protect plant stems, trunks, and branches. Tubing or thin-wall hose will not be accepted.
- B. Filter Fabric: Mirafi 140N as manufactured by Mirafi Construction Products, Pendergrass, GA.
- C. Steel Edging: 3/16" x 4" electrostatically applied, powder-coat painted steel as manufactured by the J.D. Russell Co., 1-800-888-6872
- D. Drainage Gravel: 5/8" to 1", smooth, washed gravel.

PART 3 EXECUTION

3.1 EXAMINATION

- A. Verify that prepared subsoil, planters, on-structure decks, etc. are ready to receive work. The Contractor assumes all responsibility for the correction of work installed on improper grades.
- B. Verify that required underground utilities are available, in proper location, and ready for use.
- C. Finish Grades: Verify that all grades are within one (1") inch, plus or minus, of required finish grade and that all topsoil has been installed (if applicable) as specified under Landscape Grading -Section 8.0.
- D. Notification: Submit written notification of all conditions inconsistent with specifications for site grading as described in Landscape Grading -Section 8.0.

3.2 DRAINAGE OF PLANTING AREAS

- A. Surface Drainage: Maintain positive surface drainage of planted areas as established under Landscape Grading -Section 8.0.
- B. Discrepancies: Contractor shall bear final responsibility for proper surface drainage of planted areas. Submit in writing, all discrepancies in the Drawings or Specifications, obstructions on the site, or prior work done by others, which Contractor feels precludes maintaining proper drainage. Include description of all work required for correction or relief of said responsibility.

3.3 DRAINAGE, DETRIMENTAL SOILS AND OBSTRUCTIONS

- A. Test drainage of plant beds and pits by filling with water twice in succession. Conditions permitting the retention of water in planting beds for more than twenty four (24) hours or percolation of less than one (1") inch per hour shall be brought to the attention of the Owner.
- B. Notify the Landscape Architect in writing of all soil or drainage conditions Contractor considers detrimental to growth of plant material.
- C. Obstructions: If rock, underground construction work, tree roots or other obstructions are encountered in the excavation of plant pits, alternate locations may be used as directed. Where locations cannot be changed, submit for acceptance a written proposal and cost estimate for cost required to remove the obstructions to a depth of not less than six (6") inches below the required pit depth. Proceed with work after written acceptance.

3.4 PREPARATION OF SUBSOIL

- A. Prepare subsoil to eliminate uneven areas. Maintain profiles and contours. Make changes in grade gradual. Blend slopes into level areas.
- B. Remove foreign materials, weeds and undesirable plants and their roots. Remove contaminated subsoil.
- C. Scarify subsoil to a depth of 6 inches where plants are to be placed. Repeat cultivation in areas where equipment, used for hauling and spreading topsoil, has compacted subsoil.
- D. Excavate planting pits and beds to the dimensions as shown on Detail Drawings, not less than two times the width of the root ball and slightly less than the depth of the root ball. Do not place trees on uncompacted backfill. If tree pits are excavated too deeply, add soil excavated from the tree pit and compact.

3.5 LAYOUT OF PLANTING AREAS

- A. Layout and Staking: Lay out plants at locations shown on Drawings. Use color-coded wire flags for each species of plant material. Stake the location of each tree, vine and major shrub. Outline shrub and groundcover masses and bed edges with marking paint.
- B. Locations of plants will be observed in the field by the Landscape Architect and will be adjusted to exact position before planting begins. Right is reserved to refuse review at this time if, in the Landscape Architect's opinion, a sufficient quantity of plants is not available. The Contractor shall be responsible for moving any plant material if layout was not approved by the Landscape Architect prior to planting.

3.6 STEEL EDGING

- A. General: Install edging prior to installation of adjacent sprinkler irrigation system.
- B. Edging: Install headers true to line and grade as shown on the Drawings. Align edging and set flush with adjacent paving. Curved edges shall be smooth and continuous with no flat areas or abrupt bends. Straight segments will be string-line-straight with no bows or bends.

- C. Stakes: Stakes shall be a minimum of twelve (12") inches long and longer as required for solid anchorage. Anchor with steel stakes spaced not more than three (3') feet o/c or as often as necessary to have smooth radius or straight tangent. Drive stake to one (1") inch below top of edging.

3.7 PLANTING OPERATIONS

- A. General:
 - 1. Protect plants at all times from sun or drying winds.
 - 2. Keep plants that cannot be planted immediately upon delivery in the shade, well-protected and well-watered.
- B. Do not bind or handle any plant with wire or rope at any time so as to damage bark or break branches. Lift and handle plants only from bottom of ball. Improperly handled plant material is subject to rejection.
- C. Ball and burlap (B&B) plants shall have firm balls of earth of a size to encompass enough of the fibrous and feeding root system as necessary for the complete recovery of the plant. At a minimum, root balls should be size per the American Standard for Nursery Stock (ANSI Z60.1-2004). Any plants with a root ball that is undersized, cracked or broken, before or during planting operations will not be accepted. B&B material shall be dug only when dormant. Pre-dug and stored B&B material shall be inspected and approved at the storage site. B&B trees with chicken wire or other wire mesh around the root balls will not be accepted.
- D. At Contractor's option and expense, spray all evergreen or deciduous plant material in full leaf immediately before digging with anti-desiccant, applying an adequate film over trunks, branches, twigs, and foliage.

3.8 SOIL PREPARATION

- A. General: Verify that prepared subsoil, planters, on-structure decks, etc. are ready to receive work. The Contractor assumes all responsibility for the correction of work installed on improper grades.
- B. Tree Pit Preparation:
 - 1. Excavation: Excavate planting pits and beds to the dimensions as shown on Detail Drawings, not less than two times the width of the root ball and slightly less than the depth of the root ball. Do not place trees on uncompacted backfill. If tree pits are excavated too deeply, add soil excavated from the tree pit and compact so that the top of root ball will be at 1"-2" above finished grade after settling. Scarify the walls and bottom of all plant pits immediately prior to the placement of plant and backfill mix. The Contractor shall remove all glazing caused by an auger or other mechanical excavation equipment.
 - 2. Tree Backfill Mix: Use native soil excavated from the tree pit. If the pit is excavated in rock, do not backfill with excavated material. Instead, use backfill with topsoil from on-site stockpile or import soil of a type similar to the existing site soil. Excess material is to be used for fine grading or lawfully disposed of at an off-site location depending on site grade conditions.

3. Ornamental Tree Pit Backfill: Mix soil excavated from the pits mixed with Professional Bedding Soil in a 5:1 ratio. If the pit is excavated rock, do not use excavated material as backfill. Instead, use topsoil from on-site stockpile or import soil of a type similar to the existing site soil. Mix in the same 5:1 ratio with Professional Bedding Soil. Excess tree pit spoil material is to be used for fine grading, if needed depending on site grade conditions, or lawfully disposed of at an off-site location at the Contractor's expense.
- C. Bed Preparation:
- 1 Smooth planted areas to conform to specified grades after full settlement has occurred. Contractor shall bear final responsibility for proper surface drainage of planted areas. Any discrepancy in the drawings or specifications, obstructions on the site, or prior work done by another party which Contractor feels precludes establishing proper drainage, shall be brought to the attention of the Landscape Architect in writing prior to any work being started.
 - 2 Till subsoil to a depth of 6 inches where plants are to be placed. In areas where equipment or vehicular traffic has compacted subsoil, rip or scarify the sub-grade to a depth of 12" prior to tilling.
 - 3 Uniformly spread 3 inches of compost and 3 inches of expanded shale in all bed areas and till into existing soil to a depth of 12". In seasonal color beds, use 4" of Professional Bedding Soil

3.9 TREE AND SPECIMEN SHRUB PLANTING

- A. Container stock shall be removed carefully without pulling on the trunk or stem. If required, cut can on two sides with approved cutter. Do not use spade to cut cans. Do not lift or handle container plants by trunk at any time. Prune away girdled roots and gently loosen root masses.
- B. For boxed material, break vertical bands and remove top and bottom of container. Carefully lower plant into pit, by approved method, and adjust elevation. Cut horizontal bands and remove sides. Prune away girdled roots and gently loosen root masses.
- C. Place B&B plants carefully in the prepared planting pit and adjust elevation. Backfill tree pit approximately 50%. Tamp soil and set tree plumb. Remove top 1/3 of the basket and burlap. Add and tamp the remainder of the backfill.
- D. Place bare root plant materials so roots lie in a natural position. Backfill with soil mixture in 6 inch lifts. Maintain plant in vertical position.
- E. Set plants plumb and orient for best appearance for review and final orientation by Landscape Architect, if requested.
- F. Carefully fill pits and compact by watering and tamping each eight (8") inches of backfill to support root ball.
- G. Fertilizer: Place evenly distributed in plant pits when backfilled 2/3 according to the organic maintenance specification.
- H. Adjustment: Adjust trees so that, after full settlement has occurred, the natural grade at the base of the trees is 1"-2" inches above the adjacent finish grade.

- I. Smooth surrounding areas to conform to specified grades after full settlement has occurred. Contractor shall bear final responsibility for proper surface drainage of planted areas. Any discrepancy in the drawings or specifications, obstructions on the site, or prior work done by another party which Contractor feels precludes establishing proper drainage, shall be brought to the attention of the Landscape Architect in writing.
- J. Watering Basin: Form circular ring of earth to create a three (3") inch high berm with tree or specimen shrub in the center. The inside diameter of the basin shall be equal to the diameter of the root ball.
- K. Water all trees immediately again after planting.
- L. Apply pre-emergent weed control material in areas to receive mulch.
- M. Spread mulch in watering basins to the depth of three (3") inches.
- N. Remove all flagging, tags, plastic ties, wire, string, cord or any other material that may damage the bark. DO NOT remove Landscape Architect's lock-rings or plant identification tags until instructed by the Landscape Architect.

3.10 SHRUB AND GROUNDCOVER PLANTING

- A. Tilling: Immediately prior to planting, re-till bed areas to be planted with groundcover, perennials or seasonal color.
- B. Planting: Set plant material so that the top of the root ball is slightly above the surrounding grade. Avoid air pockets. Equally space as directed by the details or plant list. Refer to details for plant mass or bed edge planting.
- C. Fertilizer: Apply topdressing fertilizer to all groundcover, perennial and seasonal color beds. Backfill all shrub pits ½ and add fertilizer per organic specifications.
- D. Smooth surrounding areas to conform to specified grades after full settlement has occurred. Contractor shall bear final responsibility for proper surface drainage of planted areas. Any discrepancy in the drawings or specifications, obstructions on the site, or prior work done by another party which Contractor feels precludes establishing proper drainage, shall be brought to the attention of the Landscape Architect in writing.
- E. Water all plant material immediately again after planting.
- F. Apply pre-emergent weed control material in areas to receive mulch.
- G. Spread mulch in bed areas to the depth of two (3") inches. Keep mulch away from plant stems.

3.11 AQUATIC PLANTING

- A. Staking: All aquatics to receive a minimum of one 3/8" re-bar pin. The pin shall be bent into an 'L' shape with the long leg 12" in length and the short leg 3" in length. Push pin

through root ball into sides or bottom of planting pit so that it is flush with the top of root ball.

- B. The following are planting requirements for various non-woody aquatics:
 - 1 Install aquatics when lakes are drained down (well turned off) below planting shelf. Planting areas to be moist but not flooded or saturated (boggy).
 - 2 Install at soil surface, but NOT above soil surface. Be sure crowns are fully covered and not washed out.
 - 3 Ensure there is full contact, with no air or water pockets, between root ball and surrounding soil. Water in.
 - 4 Install stakes as specified above.
 - 5 Maintain NON-flooded condition for minimum of three days after installation prior to restoring flooded condition.

3.12 PLANT SUPPORT

- A. Trees that are not capable of standing upright without falling or leaning shall be staked or guyed. The Contractor is responsible for material remaining plumb and straight for all given conditions through the guarantee period. Tree support shall be performed as outlined below.
- B. Staking shall be completed immediately after planting. Plants shall stand plumb after staking.
- C. Brace plants vertically with plant protector wrapped guy wires and stakes to the following:
 - 1 For trees 3" diameter and less, use two (2) steel T posts. Orient stakes, generally, one to the south of the trunk, and one to the north. Install a loop of wire from the trunk just above the lowest branches (or level with the top of the T post for plants that are full-to-the-ground) to the top of the T post. Provide hose to protect the bark of the tree. Twist the two strands of wire until slightly less than taut. DO NOT OVER-TIGHTEN. Trees should be free to move in light breezes.
 - 2 For trees larger than 3" diameter and less than 6" diameter, use three (3) steel T posts. Orient stakes, generally, two to the south of the trunk and one to the north, equally spaced. Install a loop of wire from the trunk just above the lowest branches (or level with the top of the T post for plants that are full-to-the-ground) to the top of the T post. Provide hose to protect the bark of the tree. Twist the two strands of wire until slightly less than taut. DO NOT OVERTIGHTEN. Trees should be free to move in light breezes.
 3. For trees 6" diameter and larger, use three (3) guy wires. Install three (3) ground-screw anchors oriented, generally, two to the south of the trunk, and one to the north, equally spaced. Run aircraft cable through the eye on the anchor and secure with two cable clips. Loop the other end of the cable through one eye of a turnbuckle and secure with two cable clips. Install a loop of aircraft cable, with hose to protect the bark, around the trunk just above the lowest branches and secure with two cable clips. Loop the other end of the cable through the second eye of the turnbuckle, pull tight and secure with cable clips. Remove any slack by tightening the turnbuckle. DO NOT OVER-TIGHTEN. The trees should be free to move in light breezes.
- D. Locate stakes as per Drawing Details outside root ball and as close to the main trunk as is

practical, avoiding root injury. Stakes shall be driven at least eighteen (18") inches into firm ground. Stake shall be straight and plumb. DO NOT install stakes at an angle.

Typically, stakes and guys will be oriented south to north or per local prevailing winds. Verify with Landscape Architect before installing stakes or guys. Site conditions may necessitate a different configuration.

- E. Auxiliary stem stakes shipped with trees shall be removed after planting.

3.13 TREE PRUNING

- A. Perform pruning of trees as recommended in ANSI A300.
- B. Prune newly planted trees as required to remove deadwood, suckers, broken, and split branches. DO NOT head-back any trees or remove lower branches.
- C. Prune B&B material, as may be directed by Landscape Architect, by removing a percentage of interior branching proportional to the root loss during digging (no more than 1/3).
- D. Use only clean, sharp tools.

3.14 CLEAN-UP

- A. Keep all areas of work clean, neat and orderly at all times. Clean walks and drive and remove trash daily.
- B. Clean up and remove all materials and debris from the entire site prior to Final Acceptance.

3.15 INSPECTIONS

- A. Perform field inspection and testing in accordance with Town of Addison Requirements
- B. Plants will be rejected if a ball of earth surrounding roots has been disturbed or damaged prior to or during planting.
- C. Make written request for inspections after planting operations are completed.
- D. Submit requests for progress inspections to the Owner at least two (2) days prior to anticipated inspection date.

END OF SECTION

Attachment A

Environmental Investigation



July 10, 2014
AVO 29751\WA01

The Town of Addison
16801 Westgrove Drive
Addison, TX 75001

Re: Winnwood Ponds Sediment Sampling
Located south of Prestonwood Blvd. and Belt Line Rd. intersection at Winnwood Park
Addison, Dallas County, Texas

Half Associates has completed the composite sediment sampling for the above referenced site. The Town of Addison is currently proposing to dewater and dredge the Winnwood Ponds and sampling activities were conducted to investigate the presence of polynuclear aromatic hydrocarbon (PAH), polychlorinated biphenyls (PCBs), pesticides, and metals (RCRA and copper and zinc) within the pond sediments that may have resulted from urban runoff. The Winnwood Ponds consists of three on-channel ponds (Pond 1, Pond 2, and Pond 3) with an approximate area of 1.45 acres that are located within a commercial and urban residential area that receives urban runoff through overland flow and from an unnamed tributary of White Rock Creek that enters the western side of Pond 1. Water depths within the Winnwood Ponds ranged between two (2) and ten (10) feet deep while sediment thicknesses were measured between zero (0) and three and one-half (3.5) feet.

Based on the laboratory data developed during this investigation, the following conclusions can be made:

- Copper, nickel, and zinc were detected in each of the three composite samples (SD-1, SD-2, and SD-3) at concentrations above their laboratory SDL and above their respective TSBCs; however, concentrations were below the applicable TRRP Tier 1 Residential Soil Action Levels.
- Chromium was detected in composite samples SD-2 and SD-3 at concentrations above its laboratory SDL and above its respective TSBC; however, concentrations were below its applicable TRRP Tier 1 Residential Soil Action Level.
- Chromium was detected above the laboratory SDL in composite samples SD-1 but below its TSBC and below its TRRP Tier 1 Residential Soil Action Level.
- Cadmium was detected in each of the three composite samples above the laboratory SDL but below its TRRP Tier 1 Residential Soil Action Level. There is no established TSBC for cadmium.
- Arsenic, lead, mercury, and selenium were detected in each of the three composite samples at concentrations above their respective TRRP Tier 1 Residential Soil Action Levels.
- PAH constituents acenaphthene, anthracene, benzo(a)anthracene, benzo(b)fluoranthene, benzo(g,h,i)perylene, benzo(k)fluoranthene, chrysene, fluoranthene, fluorene, indeno(1,2,3-cd)pyrene, phenanthrene, and pyrene were detected in composite sample

SD-1 above the laboratory SDL but at concentrations below the applicable TRRP Tier 1 Residential Soil Action Levels.

- PAH constituents benzo(a)anthracene, benzo(b)fluoranthene, benzo(g,h,i)perylene, benzo(k)fluoranthene, chrysene, fluoranthene, indeno(1,2,3-cd)pyrene, phenanthrene, and pyrene were detected in composite sample SD-2 above the laboratory SDL but at concentrations below the applicable TRRP Tier 1 Residential Soil Action Levels.
- PAH constituents benzo(a)anthracene, benzo(b)fluoranthene, benzo(g,h,i)perylene, benzo(k)fluoranthene, chrysene, fluoranthene, indeno(1,2,3-cd)pyrene, and phenanthrene were detected in composite sample SD-3 above the laboratory SDL but at concentrations below the applicable TRRP Tier 1 Residential Soil Action Levels.
- PAH constituents benzo(a)pyrene and dibenz(a,h)anthracene were detected in each of the three composite samples at concentrations above their respective TRRP Tier 1 Residential Soil Action Levels.
- Pesticide 4,4-DDT was detected above the laboratory SDL in composite samples SD-2 and SD-3 but below its TRRP Tier 1 Residential Soil Action Level. No other pesticides were detected above the SDL in samples SD-2 or SD-3. Pesticides were not detected in composite sample SD-1.
- Silver, acenaphthylene, naphthalene, and PCBs were not detected in composite sample SD-1 above the laboratory SDL.
- Silver, acenaphthene, anthracene, acenaphthylene, naphthalene, fluorene, and PCBs were not detected in composite sample SD-2 above the laboratory SDL.
- Silver, acenaphthene, anthracene, acenaphthylene, naphthalene, fluorene, pyrene, and PCBs were not detected in composite sample SD-3 above the laboratory SDL.
- Based on the arsenic, lead, mercury, selenium, benzo(a)pyrene and dibenz(a,h)anthracene concentrations in samples SD-1, SD-2, and SD-3 the sediments associated with the Winnwood Ponds may not be suitable for unrestricted reuse. Furthermore, based on the metals and organic constituents identified, sediments associated with the Winnwood Ponds may require disposal of as Class 1 or Class 2 material.

The analytical parameters evaluated during this investigation represent a general screening of the sediments within the Winnwood Ponds and are not intended to be used for waste classification purposes. Based on the final disposition of the sediments, the end recipient may require additional analysis beyond what was conducted as part of this investigation. Additional characterization to determine the final waste disposal classification for sediments removed from the ponds is anticipated. In addition, the sediment from Ponds 1, 2, and 3 do not appear to be suitable for unrestricted re-use based on the metals and PAH data collected.

Conclusions contained in the attached report are intended for the sole use of the client and other parties as specified in the consulting agreement between Halff Associates and the client, and will not be released to other parties without the written consent of the client.



Halff Associates is pleased to be of service to you on this project. If you have any questions regarding this report, please feel free to call me at (214) 346-6393.

Sincerely,

HALFF ASSOCIATES

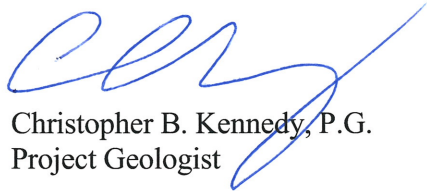
A handwritten signature in blue ink, appearing to read "C. Kennedy", written over the typed name and title.

Christopher B. Kennedy, P.G.
Project Geologist

Sediment Sampling Report

Conducted for

The Winnwood Ponds

Located South of Prestonwood Blvd and Belt Line Road

Intersection at Winnwood Park

Addison, Dallas County, Texas

Prepared for:

Town of Addison

16801 Westgrove Drive

Addison, TX 75001

Prepared By:



HALFF ASSOCIATES, INC.

1201 NORTH BOWSER ROAD
RICHARDSON, TX 75081

TEL (214) 346-6200
FAX (214) 739-0095

WWW.HALFF.COM

AVO 29751\WA01

July 2014

TABLE OF CONTENTS

1.0 INTRODUCTION AND BACKGROUND.....	1
1.1 Introduction	1
1.2 Background.....	1
2.0 FIELD INVESTIGATION.....	2
2.1 Sediment Sampling and Analysis	2
3.0 RESULTS	3
3.1 Sounding Data	3
3.2 Laboratory Data.....	3
3.2.1 Summary of Regulatory Process.....	3
3.2.2 Sediment Analytical Results	3
4.0 CONCLUSIONS	6
4.1 Conclusions	6

LIST OF FIGURES

Figure 1	Location Map
Figure 2	Sample Location Map for Winnwood Pond #1
Figure 3	Sample Location Map for Winnwood Pond #2
Figure 4	Sample Location Map for Winnwood Pond #3

LIST OF TABLES

Table 1	Summary of Sounding Data
Table 2	Summary of Analytical Results for SD-1
Table 3	Summary of Analytical Results for SD-2
Table 4	Summary of Analytical Results for SD-3
Table 5	Waste Classification Summary

APPENDICES

Appendix A	Chain of Custody Forms/Laboratory Reports
------------	-------------------------------------------

SEDIMENT SAMPLING REPORT

For

**The Winnwood Ponds
Located South of Prestonwood Boulevard and Belt Line Road Intersection
Addison, Dallas County, Texas**

1.0 INTRODUCTION AND BACKGROUND

1.1 *Introduction*

Half Associates, Inc. (Half) conducted sediment sampling activities on behalf of the Town of Addison for the Winnwood Ponds located along an unnamed tributary of White Rock Creek just south of the Prestonwood Boulevard and Belt Line Road intersection at Winnwood Park in Addison, Dallas County, Texas (Subject Property or Site). Winnwood Pond 1 is located just south of the Addison Municipal Building between Oaks Drive and Lake Forest Drive while Ponds 2 and 3 are located within Winnwood Park between Lake Forest Drive and Winnwood Road. Figure 1, the Site Location Map, shows the site location on the U.S. Geological Survey (USGS) Topographic Quadrangle Map "Addison, Texas." The sampling activities were conducted to investigate the presence of polynuclear aromatic hydrocarbon (PAH), polychlorinated biphenyls (PCBs), pesticides, and metals (RCRA and copper and zinc) within the pond sediments that may have resulted from urban runoff.

The scope of the investigation included the following tasks:

- Evaluation of each pond depth and sediment thicknesses;
- Collection and analysis of three, four-part composite sediment sample for metals (Arsenic [As], Cadmium [Cd], Chromium [Cr], Copper [Cu], Lead [Pb], Mercury [Hg], Nickel [Ni], Selenium [Se], Silver [Ag], and Zinc [Zn]) by EPA Method 6020A/7471B, and PAHs, PCBs, and pesticides by EPA Method 8270D; and
- Preparation of a brief report summarizing the work performed and including a sample location map, analytical data summary tables, and copies of analytical reports.

1.2 *Background*

The Town of Addison is currently proposing to dewater and dredge the Winnwood Ponds. The ponds are located along an unnamed tributary of White Rock Creek within an urban commercial and residential area. The ponds are surrounded by recreational hiking and biking trails with a narrow landscaped buffer zone that is composed primarily of maintained grass with native and ornamental trees. A gazebo and bridge structure is located between Ponds 2 and 3 and Pond 2 has a publicly accessible deck overlook. Ponds 1 and 3 have floating fountains that are operated by the Town of Addison. Pond 1 is approximately 0.3 acres in size; Pond 2 is approximately 0.5 acres in

size; and Pond 3 is approximately 0.65 acres in size. The ponds are configured such that Pond 1 discharges into Pond 2 through an unnamed tributary and Pond 2 then discharges into Pond 3 after passing over a man-made rock feature. Water discharging from Pond 3 re-enters the unnamed tributary of White Rock Creek after passing under Winnwood Road. The ponds range in depth from approximately 2 to 10 feet and receive urban runoff through overland flow and through the unnamed tributary of White Rock Creek which enters the west side of Pond 1.

2.0 FIELD INVESTIGATION

2.1 Sediment Sampling and Analysis

The Half Associates sediment sampling activities included the collection of sounding points at 44 locations across each of the Winnwood ponds followed by the collection of a four-part composite sediment sample from each pond for a total of three composite samples. Sounding points were collected using a graduated survey pole to determine both the depth of the pond at each location along with the approximate sediment thicknesses in the areas sounded. Sounding data was utilized to identify the areas of significant sediment accumulation which were subsequently sampled. The sounding locations along with the observed pond depths and sediment thicknesses are illustrated for each pond on the attached Figures 2, 3, and 4, Sample Location Maps.

Following the completion of the pond sounding activities, four sediment grab samples were collected from each pond using a dredge sampler from areas where either significant sediment accumulations were noted or in areas that discharge urban runoff into the ponds. For each pond, the sediment grab samples were then placed into a clean 5-gallon plastic container and then composited into a single sample. The composite sample collected from Pond 1 was comprised of sediment samples collected from the far western portion of the pond just east of the walking bridge, two locations near the central portion of the pond, and one from the far eastern portion of the pond just before Lake Forest Drive crosses over Pond 1. During the sounding activities conducted at Pond 1 several areas of thick leaf and organic debris buildup were observed across the pond. Sediment accumulations were primarily between these areas and ranged between 1 and 3.5 feet in thickness. The composite sample collected from Pond 2 was comprised of sediment samples collected from the far western portion of the pond, two locations near the south central portion of the pond, and from the north central portion of the pond. Sediment thickness in Pond 2 ranged from approximately 6 inches to 2 feet. During the sounding activities conducted at Pond 2, a large area was observed near the central portion of the pond comprised primarily of leaves and other organic debris. Furthermore, a downed tree obstructed a portion of the southern end of the pond. The composite sample collected from Pond 3 was comprised of sediment samples collected from western and central western portion, from the north central portion, and from the eastern portion of the pond. Unlike Ponds 1 and 2, significant accumulation of leaves and organic debris were not identified in Pond 3. Sediment thickness in pond three ranged from 6 inches to 2.5 feet.

Sampling equipment was thoroughly cleaned between each sediment sampling location point to prevent the possibility of cross contamination. Once composited, the representative sediment samples were placed in laboratory-supplied sample jars with Teflon-lined lids. The sediment samples were appropriately labeled and placed in an ice-filled, insulated cooler for shipment to the analytical laboratory. The sediment samples were submitted to DHL Analytical (DHL) in

Round Rock, Texas for analysis of metals (As, Cd, Cr, Cu, Pb, Hg, Ni, Se, Ag, and Zn) by EPA Method 6020A/7471B, PAHs, PCBs, and pesticides by EPA Method 8270D.

3.0 RESULTS

3.1 *Sounding Data*

Sounding data were collected from 44 locations across the three ponds. The sounding data collected included the depth of the ponds at each location sounded along with the estimated thickness of the sediment in that location. Table 1 provides a summary of the sounding data collected at the ponds and is included as an attachment to this report.

3.2 *Laboratory Data*

3.2.1 *Summary of Regulatory Process*

The Texas Risk Reduction Program (TRRP) rules as established by 30 Texas Administrative Code (TAC), Chapter 350 (30 TAC 350) specify objectives for releases that occur under the jurisdiction of a Texas Commission on Environmental Quality (TCEQ) Remediation Division Program. The intention of TRRP is to focus on releases that threaten or affect water resources or necessitate remediation. Action levels have been developed based on human health exposure pathways for surface soils, subsurface soils, and groundwater to determine which releases are subject to TRRP (“Determining What Releases are Subject to TRRP”, November 19, 2010). Action levels are defined as the lowest applicable Tier 1 residential Protective Concentration Level (PCL). If background (Texas-Specific Background Concentrations [TSBC]) is a higher concentration than the action level, then the background is the action level. The TRRP action levels for surface soil have been used as a screening criteria to evaluate the analytical data developed for the composite sediment samples collected at the subject property since dredged sediments may be re-used as surface soil once removed from the ponds.

3.2.2 *Sediment Analytical Results*

Three composite sediment samples were submitted to DHL for laboratory analysis. The three composite sediment samples were submitted for laboratory analysis of the metals arsenic, cadmium, chromium, copper, lead, mercury, nickel, selenium, silver, and zinc along with PAHs, PCBs, and pesticides. The results of the sediment sampling were compared to the TCEQ TRRP Tier 1 Residential Soil Action Levels and the TSBCs. In addition, the metals concentrations for each sample were also evaluated versus Dallas/Fort Worth area landfill permit limits to determine if the sediments from the ponds may require disposal as Class 1 or Class 2 material. The analytical results of the metals, PAH, PCB, and pesticides sampling are included on Tables 2, 3, 4, and 5. Copies of the chain of custody forms and laboratory analytical reports are included as Appendix A. The following is a summary of the results for each the composite samples:

Winnwood Pond 1(Sample SD-1)

Arsenic (7.99 mg/kg), cadmium (0.712 mg/kg), chromium (29.2 mg/kg), copper (35.7 mg/kg), lead (45.1 mg/kg), mercury (0.0405 mg/kg), nickel (24.6 mg/kg), selenium (4.08 mg/kg), and zinc (241 mg/kg) were each detected in the composite sediment sample SD-1 at concentrations above the laboratory sample detection limit (SDL). Silver was not detected in the sample above the SDL. Review of the data indicated that arsenic, copper, lead, mercury, nickel, selenium, and zinc were all detected at concentrations above their respective TSBC while chromium was below its respective TSBC. There is no established TSBC for cadmium. Cadmium, chromium, copper, nickel, silver, and zinc were not detected at concentrations above their TRRP Tier 1 Residential Soil Action Levels; however, arsenic, lead, mercury, and selenium were each detected at concentrations above their respective TRRP Tier 1 Residential Soil Action Levels.

Concentrations of the PAH constituents acenaphthene (0.116J mg/kg), anthracene (0.618 mg/kg), benzo(a)anthracene (3.1 mg/kg), benzo(a)pyrene (3.8 mg/kg), benzo(b)fluoranthene (4.52 mg/kg), benzo(g,h,i)perylene (2.42 mg/kg), benzo(k)fluoranthene (2.91 mg/kg), chrysene (4.38 mg/kg), dibenz(a,h)anthracene (0.757 mg/kg), fluoranthene (8.05 mg/kg), fluorene (0.17J mg/kg), indeno(1,2,3-cd)pyrene (2.25 mg/kg), phenanthrene (3.22 mg/kg), and pyrene (7.57 mg/kg) were detected above the laboratory SDL. Concentrations of the PAH constituents acenaphthylene and naphthalene, along with PCBs and pesticides were not detected above the laboratory SDL. Review of the PAH data indicate that benzo(a)pyrene and dibenz(a,h)anthracene were detected at concentrations above their respective the TRRP Tier 1 Residential Soil Action Levels. None of the remaining detected PAHs in SD-1 were above their respective TRRP Tier 1 Residential Soil Action Levels.

Based on the arsenic, lead, selenium, benzo(a)pyrene and dibenz(a,h)anthracene concentrations in sample SD-1, the sediments associated with Pond 1 may not be suitable for unrestricted reuse. Furthermore, based on the metals and organic constituents identified, sediments associated with Pond 1 may require disposal as Class 1 or Class 2 material. Based on the final disposition of the sediments, the end recipient may require additional analysis beyond what was conducted as part of this investigation.

Winnwood Pond 2 (Sample SD-2)

Arsenic (10.9 mg/kg), cadmium (0.93 mg/kg), chromium (44.6 mg/kg), copper (88 mg/kg), lead (43.3 mg/kg), mercury (0.0964 mg/kg), nickel (32.7 mg/kg), selenium (5.11 mg/kg), and zinc (497 mg/kg) were each detected in the composite sediment sample SD-2 at concentrations above the laboratory sample detection limit (SDL). Silver was not detected in the sample above the SDL. Review of the data indicated that arsenic, chromium, copper, lead, mercury, nickel, selenium, and zinc were all detected at concentrations above their respective TSBC. There is no established TSBC for cadmium. Cadmium, chromium, copper, nickel, and zinc were not detected at concentrations above their TRRP Tier 1 Residential Soil Action Levels; however, arsenic, lead, mercury, and selenium were each detected at concentrations above their respective TRRP Tier 1 Residential Soil Action Levels.

Concentrations of the PAH constituents benzo(a)anthracene (1.42 mg/kg), benzo(a)pyrene (2.12 mg/kg), benzo(b)fluoranthene (2.77 mg/kg), benzo(g,h,i)perylene (2.32 mg/kg), benzo(k)fluoranthene (2.02 mg/kg), chrysene (2.64 mg/kg), dibenz(a,h)anthracene (0.62 mg/kg), fluoranthene (5.11 mg/kg), indeno(1,2,3-cd)pyrene (1.99 mg/kg), phenanthrene (1.16 mg/kg), and pyrene (3.38 mg/kg) were detected above the laboratory SDL. Concentrations of the PAH constituents acenaphthene, acenaphthylene, anthracene, fluorene, and naphthalene, along with PCBs and were not detected above the laboratory SDL. Pesticides were not detected above the SDL with the exception of 4,4-DDT which was detected at a concentration of 0.0532J mg/kg. Review of the PAH data indicate that benzo(a)pyrene and dibenz(a,h)anthracene were detected at concentrations above their respective the TRRP Tier 1 Residential Soil Action Levels. None of the remaining detected PAHs or the pesticide 4,4-DDT in SD-2 were above their respective TRRP Tier 1 Residential Soil Action Levels.

Based on the arsenic, lead, mercury, selenium, benzo(a)pyrene and dibenz(a,h)anthracene concentrations in sample SD-2, the sediments associated with Pond 2 may not be suitable for unrestricted reuse. Furthermore, based on the metals and organic constituents identified, sediments associated with Pond 2 may require disposal as Class 1 or Class 2 material. Based on the final disposition of the sediments, the end recipient may require additional analysis beyond what was conducted as part of this investigation.

Winnwood Pond 3

Arsenic (10.2 mg/kg), cadmium (0.871 mg/kg), chromium (44.8 mg/kg), copper (91.6 mg/kg), lead (42.3 mg/kg), mercury (0.096 mg/kg), nickel (31.5 mg/kg), selenium (5.42 mg/kg), and zinc (487 mg/kg) were each detected in the composite sediment sample SD-3 at concentrations above the laboratory sample detection limit (SDL). Silver was not detected in the sample above the SDL. Review of the data indicate that arsenic, copper, lead, mercury, nickel, selenium, and zinc were all detected at concentrations above their respective TSBC while chromium was below its respective TSBC. There is no established TSBC for cadmium. Cadmium, chromium, copper, nickel, and zinc were not detected at concentrations above their TRRP Tier 1 Residential Soil Action Levels; however, arsenic, lead, mercury, and selenium were each detected at concentrations above their respective TRRP Tier 1 Residential Soil Action Levels.

Concentrations of the PAH constituents benzo(a)anthracene (1.27 mg/kg), benzo(a)pyrene (2.05 mg/kg), benzo(b)fluoranthene (3.20 mg/kg), benzo(g,h,i)perylene (2.25 mg/kg), benzo(k)fluoranthene (2.47 mg/kg), chrysene (2.67 mg/kg), dibenz(a,h)anthracene (0.65 mg/kg), fluoranthene (4.05 mg/kg), indeno(1,2,3-cd)pyrene (2.0 mg/kg), and phenanthrene (1.21 mg/kg), were detected above the laboratory SDL. Concentrations of the PAH constituents acenaphthene, acenaphthylene, anthracene, fluorene, naphthalene, and pyrene along with PCBs and were not detected above the laboratory SDL. Pesticides were not detected above the SDL with the exception of 4,4-DDT which was detected at a concentration of 0.0566J mg/kg. Review of the PAH data indicate that benzo(a)pyrene and dibenz(a,h)anthracene were detected at concentrations above their respective the TRRP Tier 1 Residential Soil Action Levels. None of the remaining detected PAHs or the pesticide 4,4-DDT in SD-3 were above their respective TRRP Tier 1 Residential Soil Action Levels.

Based on the arsenic, lead, mercury, selenium, benzo(a)pyrene and dibenz(a,h)anthracene concentrations in sample SD-3, the sediments associated with Pond 3 may not be suitable for unrestricted reuse. Furthermore, based on the metals and organic constituents identified, sediments associated with Pond 3 may require disposal as Class 1 or Class 2 material. Based on the final disposition of the sediments, the end recipient may require additional analysis beyond what was conducted as part of this investigation.

4.0 CONCLUSIONS

4.1 *Conclusions*

The Winnwood Ponds are comprised of three on channel ponds that comprise a total area of approximately 1.45 acres. The ponds are located along an unnamed tributary of White Rock Creek within an urban commercial and residential area of Addison, Texas. The ponds are configured such that Pond 1 discharges into Pond 2 through an unnamed tributary and Pond 2 then discharges into Pond 3 after passing over a man-made rock feature. Water discharging from Pond 3 re-enters the unnamed tributary of White Rock Creek after passing under Winnwood Road. The ponds range in depth from approximately 2 to 10 feet and receive urban runoff through overland flow and through the unnamed tributary of White Rock Creek which enters the west side of Pond 1. The majority of the measurable sediment in Pond 1 appeared to be located in small patches between areas of thick leaf and organic debris buildup. The majority of the measurable sediment in Pond 2 was located throughout the central portion of the pond and near the bridge and man-made rock feature leading to Pond 3. Measurable sediment in Pond 3 was located across the majority of the pond with the most significant accumulations observed near the central and southeastern portions of the pond.

The Town of Addison is currently proposing to dewater and dredge the Winnwood Ponds. Sampling activities were conducted to investigate the presence of PAHs, PCBs, pesticides, and metals impacted sediments within the ponds that may have resulted from urban runoff. Forty-four (44) locations were sounded across the three ponds to determine pond depths along with relative sediment thicknesses. Based on the sounding results four-part composite sediment samples were collected from each pond and submitted for laboratory analysis of RCRA metals ([As], [Cd], [Cr], [Cu], [Pb], [Hg], [Ni], [Se], [Ag], and [Zn]) by EPA Method 6020A/7471B and PAHs, PCBs, and pesticides by EPA Method 8270D.

Based on the laboratory data developed during this investigation, the following conclusions can be made:

Pond-1 (Composite Sample SD-1)

- Copper, nickel, and zinc were detected in composite sample SD-1 at concentrations above the laboratory SDL and above their respective TSBCs; however, concentrations were below the applicable TRRP Tier 1 Residential Soil Action Levels.
- Chromium was detected above the laboratory SDL in composite sample SD-1 but below its TSBC and below its TRRP Tier 1 Residential Soil Action Level.
- Cadmium was detected above the laboratory SDL in composite sample SD-1 but below its TRRP Tier 1 Residential Soil Action Level. There is no established TSBC for cadmium.
- Arsenic, lead, and selenium were detected in composite sample SD-1 at concentrations above their respective TRRP Tier 1 Residential Soil Action Levels.
- PAH constituents acenaphthene, anthracene, benzo(a)anthracene, benzo(b)fluoranthene, benzo(g,h,i)perylene, benzo(k)fluoranthene, chrysene, fluoranthene, fluorene, indeno(1,2,3-cd)pyrene, phenanthrene, and pyrene were detected in composite sample SD-1 above the laboratory SDL but at concentrations below the applicable TRRP Tier 1 Residential Soil Action Levels.
- PAH constituents benzo(a)pyrene and dibenz(a,h)anthracene were detected in composite sample SD-1 at concentrations above their respective TRRP Tier 1 Residential Soil Action Levels.
- Silver, acenaphthylene, naphthalene, pesticides and PCBs were not detected in composite sample SD-1 above the laboratory SDL.
- Based on the arsenic, lead, selenium, benzo(a)pyrene and dibenz(a,h)anthracene concentrations in sample SD-1, the sediments associated with Pond 1 may not be suitable for unrestricted reuse. Furthermore, based on the metals and organic constituents identified, sediments associated with Pond 1 may require disposal of as Class 1 or Class 2 material.

Pond-2 (Composite Sample SD-2)

- Chromium, copper, nickel, and zinc were detected in composite sample SD-2 at concentrations above the laboratory SDL and above their respective TSBCs; however, concentrations were below the applicable TRRP Tier 1 Residential Soil Action Levels.
- Cadmium was detected above the laboratory SDL in composite sample SD-2 but below its TRRP Tier 1 Residential Soil Action Level. There is no established TSBC for cadmium.
- Arsenic, lead, mercury, and selenium were detected in composite sample SD-2 at concentrations above their respective TRRP Tier 1 Residential Soil Action Levels.
- PAH constituents benzo(a)anthracene, benzo(b)fluoranthene, benzo(g,h,i)perylene, benzo(k)fluoranthene, chrysene, fluoranthene, indeno(1,2,3-cd)pyrene, phenanthrene, and pyrene were detected in composite sample SD-2 above the laboratory SDL but at concentrations below the applicable TRRP Tier 1 Residential Soil Action Levels.

- PAH constituents benzo(a)pyrene and dibenz(a,h)anthracene were detected in composite sample SD-2 above the laboratory SDL and at concentrations above their respective TRRP Tier 1 Residential Soil Action Levels.
- Pesticide 4,4-DDT was detected above the laboratory SDL in composite sample SD-2 but below its TRRP Tier 1 Residential Soil Action Level. No other pesticides were detected above the SDL.
- Silver, acenaphthene, anthracene, acenaphthylene, naphthalene, fluorene, and PCBs were not detected in composite sample SD-2 above the laboratory SDL.
- Based on the arsenic, lead, mercury, selenium, benzo(a)pyrene and dibenz(a,h)anthracene concentrations in sample SD-2, the sediments associated with Pond 2 may not be suitable for unrestricted reuse. Furthermore, based on the metals and organic constituents identified, sediments associated with Pond 1 may require disposal of as Class 1 or Class 2 material.

Pond-3 (Composite Sample SD-3)

- Chromium, copper, nickel, and zinc were detected in composite sample SD-3 at concentrations above the laboratory SDL and above their respective TSBCs; however, concentrations were below the applicable TRRP Tier 1 Residential Soil Action Levels.
- Cadmium was detected above the laboratory SDL in composite sample SD-3 but below its TRRP Tier 1 Residential Soil Action Level. There is no established TSBC for cadmium.
- Arsenic, lead, mercury, and selenium were detected in composite sample SD-3 at concentrations above their respective TRRP Tier 1 Residential Soil Action Levels.
- PAH constituents benzo(a)anthracene, benzo(b)fluoranthene, benzo(g,h,i)perylene, benzo(k)fluoranthene, chrysene, fluoranthene, indeno(1,2,3-cd)pyrene, and phenanthrene were detected in composite sample SD-3 above the laboratory SDL but at concentrations below the applicable TRRP Tier 1 Residential Soil Action Levels.
- PAH constituents benzo(a)pyrene and dibenz(a,h)anthracene were detected in composite sample SD-3 above their respective TRRP Tier 1 Residential Soil Action Levels.
- Pesticide 4,4-DDT was detected above the laboratory SDL in composite sample SD-3 but below its TRRP Tier 1 Residential Soil Action Level. No other pesticides were detected above the SDL.
- Silver, acenaphthene, anthracene, acenaphthylene, naphthalene, fluorene, pyrene, and PCBs were not detected in composite sample SD-3 above the laboratory SDL.
- Based on the arsenic, lead, mercury, selenium, benzo(a)pyrene and dibenz(a,h)anthracene concentrations in sample SD-3, the sediments associated with Pond 3 may not be suitable for unrestricted reuse. Furthermore, based on the metals and organic constituents identified, sediments associated with Pond 1 may require disposal of as Class 1 or Class 2 material.

The analytical parameters evaluated during this investigation represent a general screening of the sediments within the Winnwood Ponds and are not intended to be used for waste classification purposes. Based on the final disposition of the sediments, the end recipient may require additional analysis beyond what was conducted as part of this investigation. Additional characterization to determine the final waste disposal classification for sediments removed from

the ponds is anticipated. In addition, the sediment from Ponds 1, 2, and 3 do not appear to be suitable for unrestricted re-use based on the metals and PAH data collected.

The laboratory data presented in this report are indicative of the conditions that existed at the precise locations sampled, and at the time the sample was collected. Additionally, the data should be interpreted as being meaningful with respect to the parameters indicated in the laboratory report. Additionally, Halff Associates does not represent the analytical data as being true and correct; that is the sole responsibility of the laboratory. Conclusions contained in this report are intended for the sole use of the client and other parties as specified in the consulting agreement between Halff Associates and the client, and will not be released to other parties without the written consent of the client.

FIGURES

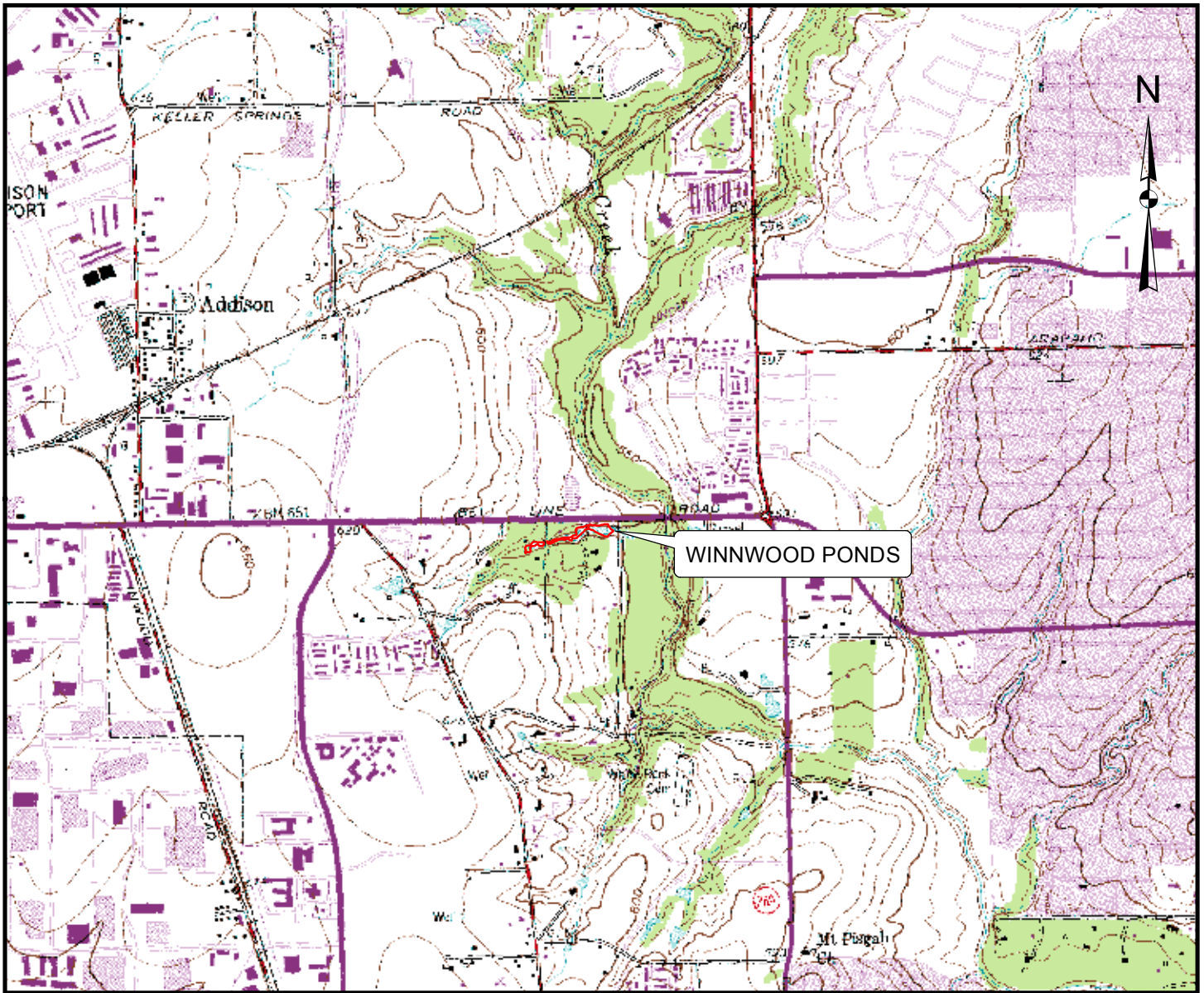

SCALE 1: 24000

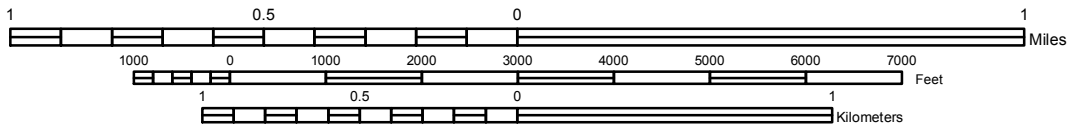

CONTOUR INTERVAL 10 FEET
 DOTTED LINES REPRESENT 5-FOOT CONTOURS
 NATIONAL GEODETIC VERTICAL DATUM OF 1929

ADDISON QUADRANGLE
 TEXAS -DALLAS CO.
 7.5 MINUTE SERIES (TOPOGRAPHIC)

FIGURE 1
LOCATION MAP

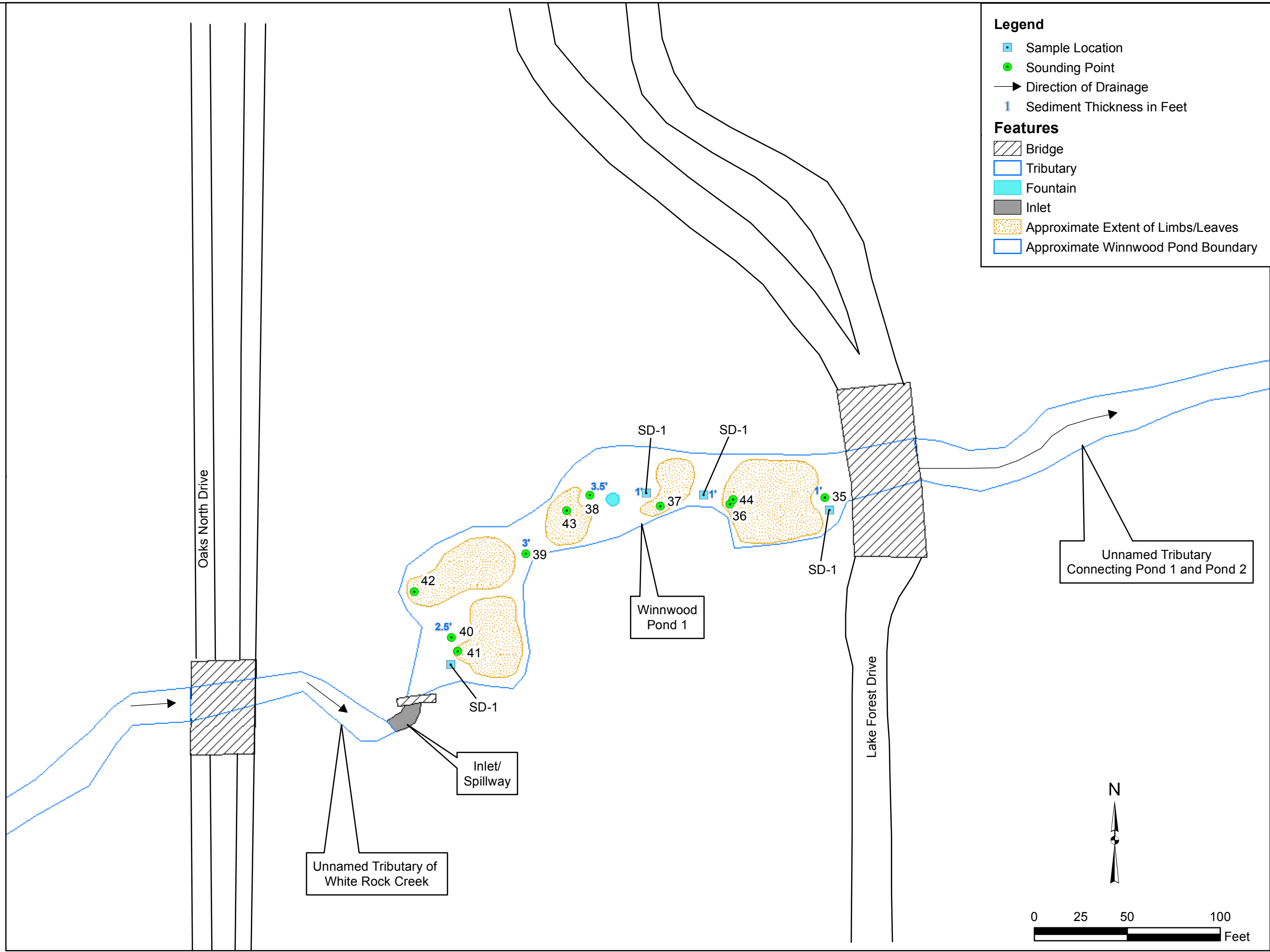

HALFF
 1201 NORTH BOWSER ROAD
 RICHARDSON, TEXAS 75081-2275
 TEL. (214) 346-6200
 FAX. (214) 739-0085

**SAMPLE LOCATION MAP
 WINNWOOD POND #1
 ADDISON, TX
 TOWN OF ADDISON**

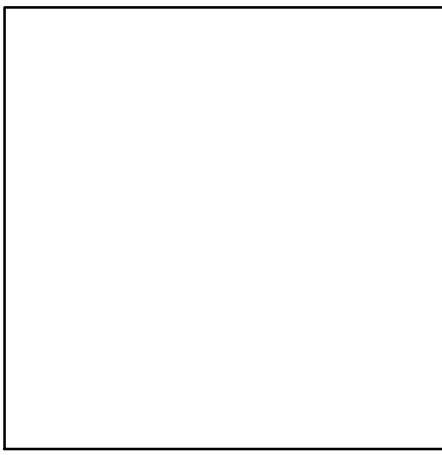
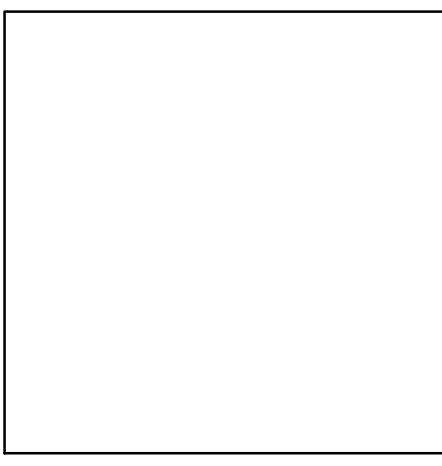

Project No.:	29751/WA01
Issued:	JULY 2014
Drawn By:	CM
Checked By:	CK
Scale:	AS NOTED
Sheet Title	SAMPLE LOCATION MAP WINNWOOD POND #1 ADDISON, TX
	TOWN OF ADDISON

Figure Number **2**

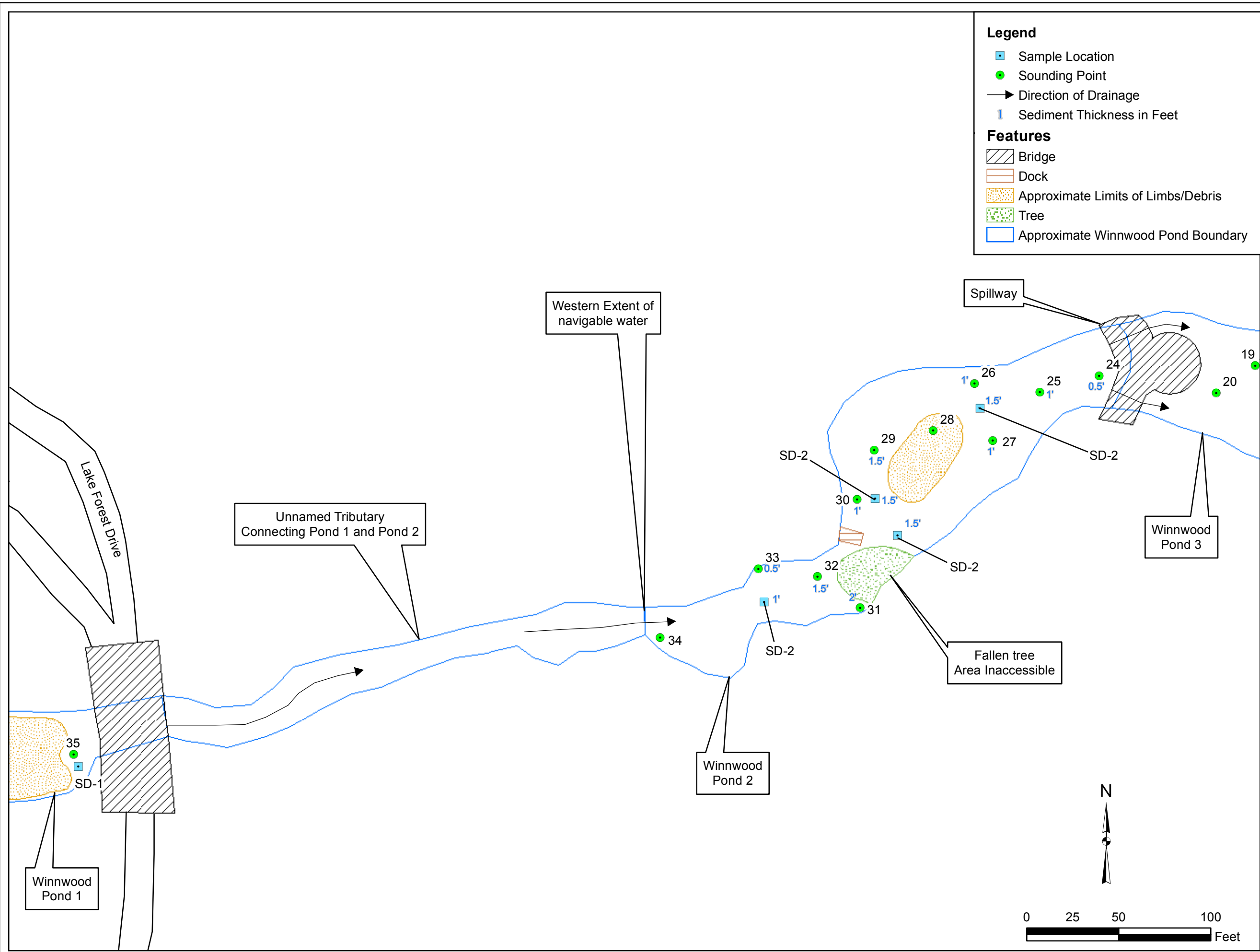

Legend

- Sample Location
- Sounding Point
- Direction of Drainage
- Sediment Thickness in Feet

Features

- Bridge
- Dock
- Approximate Limits of Limbs/Debris
- Tree
- Approximate Winnwood Pond Boundary

HALFF
 1201 NORTH BOWSER ROAD
 RICHARDSON, TEXAS 75081-2275
 TEL. (214) 346-6200
 FAX. (214) 739-0085

**SAMPLE LOCATION MAP
 WINNWOOD POND #2
 ADDISON, TX
 TOWN OF ADDISON**

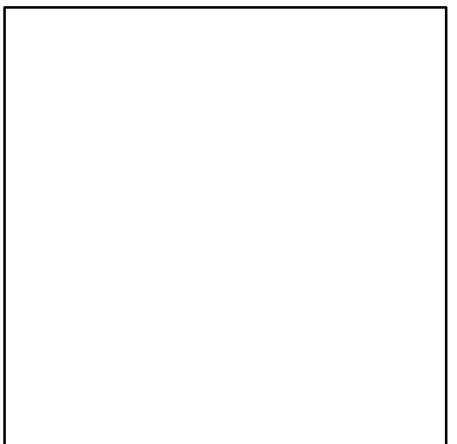
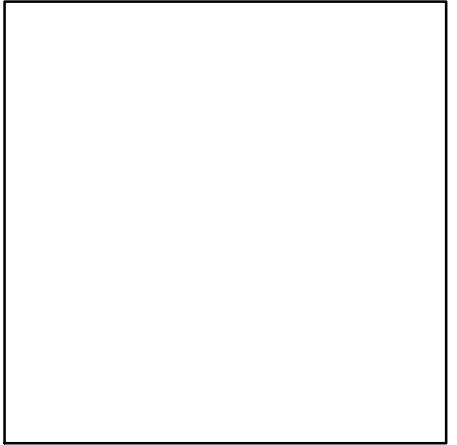



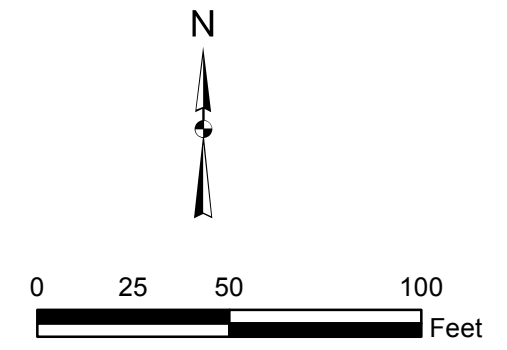

Project No.:	29751/WA01
Issued:	JULY 2014
Drawn By:	CM
Checked By:	CK
Scale:	AS NOTED
Sheet Title	SAMPLE LOCATION MAP WINNWOOD POND #2 ADDISON, TX TOWN OF ADDISON

Figure Number **3**



Belt Line Road

Legend

-  Sample Location
-  Sounding Point
-  Roadways
-  Direction of Drainage
-  Sediment Thickness in Feet

Features

-  Bridge
-  Fountain
-  Approximate Winnwood Pond Boundary



1201 NORTH BOWSER ROAD
RICHARDSON, TEXAS 75081-2275
TEL. (214) 346-6200
FAX. (214) 739-0085

**SAMPLE LOCATION MAP
WINNWOOD POND #3
ADDISON, TX
TOWN OF ADDISON**

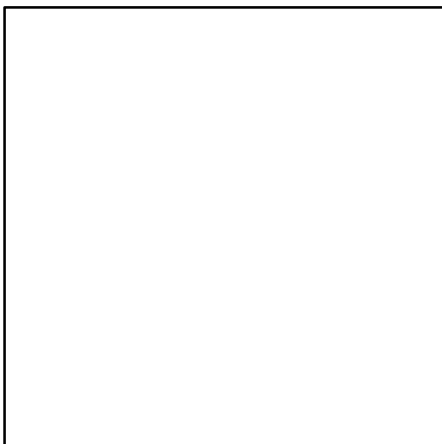
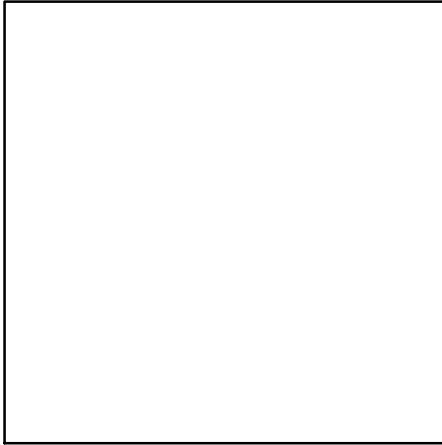
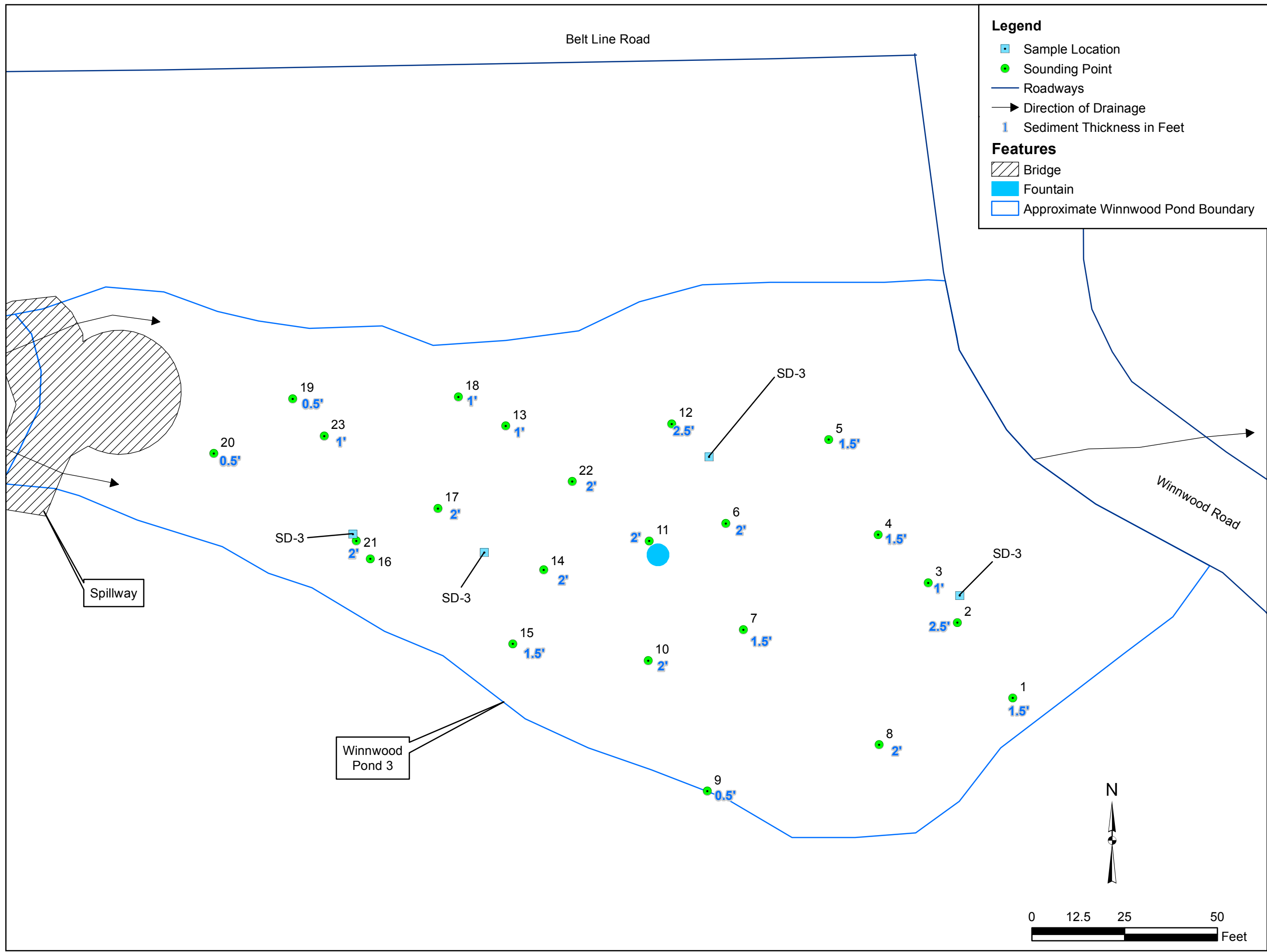

Project No.:	29751/WA01
Issued:	JULY 2014
Drawn By:	CM
Checked By:	CK
Scale:	AS NOTED
Sheet Title	SAMPLE LOCATION MAP WINNWOOD POND #3 ADDISON, TX TOWN OF ADDISON

Figure Number **4**

TABLES

**Table 1
Summary of Sounding Data
Winnwood Ponds
Town of Addison**

Pond ID	Field ID	Pond Depth (ft.)	Estimated Sediment Thickness (ft.)	Observations
Pond 1	35	4	1	Sediment was fine and silty with some sand. Hard bottom after sediment.
	36	8	2.5	Sediment was fine and silty with some sand. Hard bottom after sediment.
	37	4	None	Approximately 6 feet of leaves and other organic debris then hard bottom.
	38	5	3.5	Sediment was fine and silty with some sand and organics. Hard bottom after sediment.
	39	4	3	Sediment was fine and silty with some sand and organics. Hard bottom after sediment.
	40	5.5	2.5	Sediment was fine and silty with some sand and organics. Hard bottom after sediment.
	41	5	None	Thick area of leaves and organic debris then hard bottom. Thickness could not be determined.
	42	4	None	Approximately 5 feet of leaves and other organic debris then hard bottom.
Pond 2	43	4	None	Thick area of leaves and organic debris then hard bottom. Thickness could not be determined.
	44	5	None	Approximately 5 feet of leaves and other organic debris then hard bottom.
	19	7	0.5	Sediment was fine and silty with some sand and organics. Hard bottom after sediment.
	20	6	0.5	Sediment was fine and silty with some sand and organics. Hard bottom after sediment.
	21	5.5	2	Sediment was fine and silty with some sand and organics. Hard bottom after sediment.
	22	8	None	Thick area of leaves and organic debris. Thickness could not be determined.
	23	6.5	None	Thick area of leaves and organic debris. Thickness could not be determined.
	24	7	0.5	Sediment was fine and silty with some sand. Hard bottom after sediment.
	25	6.5	1	Sediment was fine and silty with some sand. Hard bottom after sediment.
	26	5.5	1.5	Sediment was fine and silty with some sand. Hard bottom after sediment.
	27	5	1	Sediment was fine and silty with some sand. Hard bottom after sediment.
	28	3	None	Tree limbs noted from 3 to 5 feet.
	29	3.5	1.5	Sediment was fine and silty with some sand. Hard bottom after sediment.
	30	4.5	1	Sediment was fine and silty with some sand. Hard bottom after sediment.
Pond 3	31	3	2	Gravel mixed with sediment. Hard bottom.
	32	3.5	1.5	Sediment mixed with leaves and other organic debris. Hard bottom.
	33	4	0.5	Sediment mixed with leaves and other organic debris. Hard bottom.
	34	2	None	Hard bottom after sediment.
	1	9	1.5	Sediment was fine and silty with some sand and organics. Hard bottom after sediment.
	2	9	2.5	Sediment was fine and silty with some sand and organics. Hard bottom after sediment.
	3	9.5	1	Sediment was fine and silty with some sand and organics. Hard bottom after sediment.
	4	9.5	1.5	Sediment was fine and silty with some sand and organics. Hard bottom after sediment.
	5	8	1.5	Sediment was fine and silty with some sand and organics. Hard bottom after sediment.
	6	9	2	Sediment was fine and silty with some sand and organics. Hard bottom after sediment.
	7	9.5	1.5	Sediment was fine and silty with some sand and organics. Hard bottom after sediment.
	8	8.5	2	Sediment was fine and silty with some sand and organics. Hard bottom after sediment.
	9	4.5	1.5	Sediment was fine and silty with some sand and organics. Hard bottom after sediment.
	10	9.5	2	Sediment was fine and silty with some sand and organics. Hard bottom after sediment.
	11	10	2	Sediment was fine and silty with some sand and organics. Hard bottom after sediment.
	12	9	2.5	Sediment was fine and silty with some sand and organics. Hard bottom after sediment.
	13	6.5	1	Sediment was fine and silty with some sand and organics. Hard bottom after sediment.
	14	8.5	2	Sediment was fine and silty with some sand and organics. Hard bottom after sediment.
15	6	1.5	Sediment was fine and silty with some sand and organics. Hard bottom after sediment.	
16	5	2	Sediment was fine and silty with some sand and organics. Hard bottom after sediment.	
17	7.5	2	Sediment was fine and silty with some sand and organics. Hard bottom after sediment.	
18	6.5	1	Sediment was fine and silty with some sand and organics. Hard bottom after sediment.	

Table 2
Summary of Analytical Results for SD-1
Winnwood Ponds - Pond 1
Town of Addison

Sample ID:	SD-1 (Composite)	Texas Specific Background Concentrations	TRRP Tier 1 Residential Soil Action Levels
Date:	5/14/2014		
Units	mg/kg	mg/kg	mg/kg
Total Metals:			
Arsenic	7.99	5.90	5.9
Cadmium	0.712	NE	1.5
Chromium	29.2	30	2,400
Copper	35.7	15	1,000
Lead	45.1	15	15
Mercury	0.0405	0.04	0.04
Nickel	24.6	10	160
Selenium	4.08	0.3	2.3
Silver	<0.119	NE	0.48
Zinc	241	30	2,400
Pesticides:			
4,4-DDD	<0.240	NE	13
4,4-DDE	<0.240	NE	12
4,4-DDT	<0.240	NE	15
Aldrin	<0.240	NE	0.1
alpha-BHC	<0.240	NE	0.0079
alpha-Chlordane	<0.240	NE	740
beta-BHC	<0.240	NE	0.029
Chlordane	<0.120	NE	9.6
delta-BHC	<0.240	NE	0.17
Dieldrin	<0.240	NE	0.049
Endosulfan I	<0.240	NE	31
Endosulfan II	<0.240	NE	92
Endosulfan Sulfate	<0.240	NE	4,700
Endrin	<0.240	NE	0.75
Endrin Aldehyde	<0.240	NE	630
Endrin Ketone	<0.240	NE	51
gamma-BHC	<0.240	NE	0.0092
gamma-Chlordane	<0.240	NE	41
Heptachlor	<0.240	NE	0.19
Heptachlor Epoxide	<0.240	NE	0.058
Methoxychlor	<0.240	NE	120
Toxaphene	<0.240	NE	12

Table 2
Summary of Analytical Results for SD-1
Winnwood Ponds - Pond 1
Town of Addison

Sample ID:	SD-1 (Composite)	Texas Specific Background Concentrations	TRRP Tier 1 Residential Soil Action Levels
Date:	5/14/2014		
Units	mg/kg	mg/kg	mg/kg
PAHs:			
Acenaphthene	0.116 J	NE	240
Acenaphthylene	<0.116	NE	410
Anthracene	0.618	NE	6,900
Benzo(a)anthracene	3.1	NE	5.7
Benzo(a)pyrene	3.8	NE	0.56
Benzo(b)fluoranthene	4.52	NE	5.7
Benzo(g,h,i)perylene	2.42	NE	1,800
Benzo(k)fluoranthene	2.91	NE	57
Chrysene	4.38	NE	560
Dibenz(a,h)anthracene	0.757	NE	0.55
Fluoranthene	8.05	NE	1,900
Fluorene	0.17 J	NE	300
Indeno(1,2,3-cd)pyrene	2.25	NE	5.7
Naphthalene	<0.116	NE	31
Phenanthrene	3.22	NE	420
Pyrene	7.57	NE	1,100
PCBs:			
Aroclor 1016	<0.193	NE	1.1
Aroclor 1221	<0.193	NE	1.1
Aroclor 1232	<0.193	NE	1.1
Aroclor 1242	<0.193	NE	1.1
Aroclor 1248	<0.193	NE	1.1
Aroclor 1254	<0.193	NE	1.1
Aroclor 1260	<0.193	NE	1.1
Total PCBs	<0.193	NE	1.1

Notes:

mg/kg - milligrams per kilogram

NE - Not Established

J - Estimated value. Analyte detected below quantitation limits but above sample detection limits.

Bolded value indicates result exceeds the TRRP Tier 1 Residential Soil Action Level.

Soil PCLs based on the June 29, 2012 TRRP Tables.

Table 3
Summary of Analytical Results for SD-2
Winnwood Ponds - Pond 2
Town of Addison

Sample ID:	SD-2 (Composite)	Texas Specific Background Concentrations	TRRP Tier 1 Residential Soil Action Levels
Date:	5/14/2014		
Units	mg/kg	mg/kg	mg/kg
Total Metals:			
Arsenic	10.9	5.90	5.9
Cadmium	0.93	NE	1.5
Chromium	44.6	30	2,400
Copper	88	15	1,000
Lead	43.3	15	15
Mercury	0.0964	0.04	0.04
Nickel	32.7	10	160
Selenium	5.11	0.3	2.3
Silver	<0.239	NE	0.48
Zinc	497	30	2,400
Pesticides:			
4,4-DDD	<0.0444	NE	13
4,4-DDE	<0.0444	NE	12
4,4-DDT	0.0532 J	NE	15
Aldrin	<0.0444	NE	0.1
alpha-BHC	<0.0444	NE	0.0079
alpha-Chlordane	<0.0444	NE	740
beta-BHC	<0.0444	NE	0.029
Chlordane	<0.222	NE	9.6
delta-BHC	<0.0444	NE	0.17
Dieldrin	<0.0444	NE	0.049
Endosulfan I	<0.0444	NE	31
Endosulfan II	<0.0444	NE	92
Endosulfan Sulfate	<0.0444	NE	4,700
Endrin	<0.0444	NE	0.75
Endrin Aldehyde	<0.0444	NE	630
Endrin Ketone	<0.0444	NE	51
gamma-BHC	<0.0444	NE	0.0092
gamma-Chlordane	<0.0444	NE	41
Heptachlor	<0.0444	NE	0.19
Heptachlor Epoxide	<0.0444	NE	0.058
Methoxychlor	<0.0444	NE	120
Toxaphene	<1.77	NE	12

Table 3
Summary of Analytical Results for SD-2
Winnwood Ponds - Pond 2
Town of Addison

Sample ID:	SD-2 (Composite)	Texas Specific Background Concentrations	TRRP Tier 1 Residential Soil Action Levels
Date:	5/14/2014		
Units	mg/kg	mg/kg	mg/kg
PAHs:			
Acenaphthene	<0.232	NE	240
Acenaphthylene	<0.232	NE	410
Anthracene	<0.232	NE	6,900
Benzo(a)anthracene	1.42	NE	5.7
Benzo(a)pyrene	2.12	NE	0.56
Benzo(b)fluoranthene	2.77	NE	5.7
Benzo(g,h,i)perylene	2.32	NE	1,800
Benzo(k)fluoranthene	2.02	NE	57
Chrysene	2.64	NE	560
Dibenz(a,h)anthracene	0.62	NE	0.55
Fluoranthene	5.11	NE	1,900
Fluorene	<0.232	NE	300
Indeno(1,2,3-cd)pyrene	1.99	NE	5.7
Naphthalene	<0.232	NE	31
Phenanthrene	1.16	NE	420
Pyrene	3.38	NE	1,100
PCBs:			
Aroclor 1016	<0.386	NE	1.1
Aroclor 1221	<0.386	NE	1.1
Aroclor 1232	<0.386	NE	1.1
Aroclor 1242	<0.386	NE	1.1
Aroclor 1248	<0.386	NE	1.1
Aroclor 1254	<0.386	NE	1.1
Aroclor 1260	<0.386	NE	1.1
Total PCBs	<0.386	NE	1.1

Notes:

mg/kg - milligrams per kilogram

NE - Not Established

J - Estimated value. Analyte detected below quantitation limits but above sample detection limits.

Bolded value indicates result exceeds the TRRP Tier 1 Residential Soil Action Level.

Soil PCLs based on the June 29, 2012 TRRP Tables.

Table 4
Summary of Analytical Results for SD-3
Winnwood Ponds - Pond 3
Town of Addison

Sample ID:	SD-3 (Composite)	Texas Specific Background Concentrations	TRRP Tier 1 Residential Soil Action Levels
Date:	5/14/2014		
Units	mg/kg	mg/kg	mg/kg
Total Metals:			
Arsenic	10.2	5.90	5.9
Cadmium	0.871	NE	1.5
Chromium	44.8	30	2,400
Copper	91.6	15	1,000
Lead	42.3	15	15
Mercury	0.096	0.04	0.04
Nickel	31.5	10	160
Selenium	5.42	0.3	2.3
Silver	<0.309	NE	0.48
Zinc	487	30	2,400
Pesticides:			
4,4-DDD	<0.0468	NE	13
4,4-DDE	<0.0468	NE	12
4,4-DDT	0.0566 J	NE	15
Aldrin	<0.0468	NE	0.1
alpha-BHC	<0.0468	NE	0.0079
alpha-Chlordane	<0.0468	NE	740
beta-BHC	<0.0468	NE	0.029
Chlordane	<0.234	NE	9.6
delta-BHC	<0.0468	NE	0.17
Dieldrin	<0.0468	NE	0.049
Endosulfan I	<0.0468	NE	31
Endosulfan II	<0.0468	NE	92
Endosulfan Sulfate	<0.0468	NE	4,700
Endrin	<0.0468	NE	0.75
Endrin Aldehyde	<0.0468	NE	630
Endrin Ketone	<0.0468	NE	51
gamma-BHC	<0.0468	NE	0.0092
gamma-Chlordane	<0.0468	NE	41
Heptachlor	<0.0468	NE	0.19
Heptachlor Epoxide	<0.0468	NE	0.058
Methoxychlor	<0.0468	NE	120
Toxaphene	<1.87	NE	12

Table 4
Summary of Analytical Results for SD-3
Winnwood Ponds - Pond 3
Town of Addison

Sample ID:	SD-3 (Composite)	Texas Specific Background Concentrations	TRRP Tier 1 Residential Soil Action Levels
Date:	5/14/2014		
Units	mg/kg	mg/kg	mg/kg
PAHs:			
Acenaphthene	<0.228	NE	240
Acenaphthylene	<0.228	NE	410
Anthracene	<0.228	NE	6,900
Benzo(a)anthracene	1.27	NE	5.7
Benzo(a)pyrene	2.05	NE	0.56
Benzo(b)fluoranthene	3.20	NE	5.7
Benzo(g,h,i)perylene	2.25	NE	1,800
Benzo(k)fluoranthene	2.47	NE	57
Chrysene	2.67	NE	560
Dibenz(a,h)anthracene	0.65	NE	0.55
Fluoranthene	4.05	NE	1,900
Fluorene	<0.228	NE	300
Indeno(1,2,3-cd)pyrene	2.00	NE	5.7
Naphthalene	<0.228	NE	31
Phenanthrene	1.21	NE	420
Pyrene	<0.228	NE	1,100
PCBs:			
Aroclor 1016	<0.379	NE	1.1
Aroclor 1221	<0.379	NE	1.1
Aroclor 1232	<0.379	NE	1.1
Aroclor 1242	<0.379	NE	1.1
Aroclor 1248	<0.379	NE	1.1
Aroclor 1254	<0.379	NE	1.1
Aroclor 1260	<0.379	NE	1.1
Total PCBs	<0.379	NE	1.1

Notes:

mg/kg - milligrams per kilogram

NE - Not Established

J - Estimated value. Analyte detected below quantitation limits but above sample detection limits.

Bolded value indicates result exceeds the TRRP Tier 1 Residential Soil Action Level.

Soil PCLs based on the June 29, 2012 TRRP Tables.

**Table 5
Waste Classification Summary
Winnwood Ponds
Town of Addison**

Sample I.D.	Sample Date	Total Concentrations					
		Arsenic* (mg/kg)	Lead* (mg/kg)	Mercury* (mg/kg)	Selenium* (mg/kg)	benzo(a)pyrene* (mg/kg)	dibenz(a,h)anthracene* (mg/kg)
SD-1 (Pond 1)	5/14/2014	7.99	45.1	0.0405	4.08	3.8	0.757
SD-2 (Pond 2)	5/14/2014	10.9	43.3	0.0964	5.11	2.12	0.62
SD-3 (Pond 3)	5/14/2014	10.2	42.3	0.096	5.42	2.05	0.65
Texas Class 1 Regulaotry Levels (mg/kg)		<100	<100	<4	<20	NE	NE
Texas Class 2 Regualtory Level(mg/kg)		<36	<30	NE	NE	NE	NE

Notes:

mg/kg - milligrams per kilogram

NE - Not Established

Texas Class 1 and Class 2 Regulatory Levels based on DFW area landfill permit limits

Bolded values exceed the Texas Class 2 Regulatory Level

APPENDIX A
CHAIN OF CUSTODY FORMS/LABORATORY REPORTS



June 02, 2014

Kent Belaire
Halff Associates, Inc
1201 North Bowser Road
Richardson, Texas 75081

TEL: (214) 346-6392

FAX (214) 273-1307

RE: Winnwood Ponds - Addison

Order No.: 1405176

Dear Kent Belaire:

DHL Analytical, Inc. received 3 sample(s) on 5/15/2014 for the analyses presented in the following report.

REVISION#1 This revision consists of reporting only the PAH compounds for the Semivolatiles analysis as per the client. Please replace this revised report with the original report.

There were no problems with the analyses and all data met requirements of NELAC except where noted in the Case Narrative. All non-NELAC methods will be identified accordingly in the case narrative and all estimated uncertainties of test results are within method or EPA specifications.

If you have any questions regarding these tests results, please feel free to call. Thank you for using DHL Analytical.

Sincerely,

A handwritten signature in red ink, appearing to read 'John DuPont', written in a cursive style.

John DuPont
General Manager

This report was performed under the accreditation of the State of Texas Laboratory Certification Number: T104704211-14-12



Table of Contents

Miscellaneous Documents	3
CaseNarrative 1405176	9
WorkOrderSampleSummary 1405176	11
PrepDatesReport 1405176	12
AnalyticalDatesReport 1405176	13
Analytical Report 1405176	14
AnalyticalQCSummaryReport 1405176	20
MQLSummaryReport 1405176	48



Airbill No. Z0918714

Lone Star Overnight
1-800-800-8984
www.lso.com

SHIP TO:
JENNIFER BARKER
DHL ANALYTICAL
2300 DOUBLE CREEK DR.
ROUND ROCK, TX 78664
5123888222

From:
CAROL MAY
HALFF ASSOCIATES
1201 NORTH BOWSER RD
RICHARDSON, TX 75081
2143466200

B AUS

LSO PRIORITY OVERNIGHT
10:30 IN MOST CITIES
LATER IN REMOTE CITIES

PRINT DATE: 5/14/2014
QUICKCODE: DHL ANALYTICAL
REF 1: N/A 1D00V.0000

WEIGHT: 60.00LBS

CUSTODY SEAL
DATE: 5/14/14

QEC
Environmental Containers
1-800-304-255-3900

Sample Receipt Checklist

Client Name Halff Associates, Inc

Date Received: 5/15/2014

Work Order Number 1405176

Received by JB

Checklist completed by: [Signature] 5/15/2014
Signature Date

Reviewed by: [Initials] 5/15/2014
Initials Date

Carrier name LoneStar

- Shipping container/cooler in good condition? Yes [checked] No [] Not Present []
Custody seals intact on shipping container/cooler? Yes [checked] No [] Not Present []
Custody seals intact on sample bottles? Yes [] No [] Not Present [checked]
Chain of custody present? Yes [checked] No []
Chain of custody signed when relinquished and received? Yes [checked] No []
Chain of custody agrees with sample labels? Yes [checked] No []
Samples in proper container/bottle? Yes [checked] No []
Sample containers intact? Yes [checked] No []
Sufficient sample volume for indicated test? Yes [checked] No []
All samples received within holding time? Yes [checked] No []
Container/Temp Blank temperature in compliance? Yes [checked] No [] 1.2 °C
Water - VOA vials have zero headspace? Yes [] No [] No VOA vials submitted [checked]
Water - pH<2 acceptable upon receipt? Yes [] No [] NA [checked] LOT #
Adjusted? _____ Checked by _____
Water - pH>9 (S) or pH>12 (CN) acceptable upon receipt? Yes [] No [] NA [checked] LOT #
Adjusted? _____ Checked by _____

Any No response must be detailed in the comments section below.

Client contacted _____ Date contacted: _____ Person contacted _____

Contacted by: _____ Regarding _____

Comments: _____

Corrective Action _____

DHL Analytical, Inc.							
Laboratory Review Checklist: Reportable Data							
Project Name: Winnwood Ponds - Addison			Date: 6/2/14				
Reviewer Name: Carlos Castro			Laboratory Work Order: 1405176				
Prep Batch Number(s): See Prep Dates Report			Run Batch: See Analytical Dates Report				
# ¹	A ²	Description	Yes	No	NA ³	NR ⁴	ER# ⁵
		Chain-of-Custody (C-O-C)					
R1	OI	1) Did samples meet the laboratory's standard conditions of sample acceptability upon receipt?	X				R1-01
		2) Were all departures from standard conditions described in an exception report?			X		
R2	OI	Sample and Quality Control (QC) Identification					
		1) Are all field sample ID numbers cross-referenced to the laboratory ID numbers?	X				
		2) Are all laboratory ID numbers cross-referenced to the corresponding QC data?	X				
R3	OI	Test Reports					
		1) Were all samples prepared and analyzed within holding times?	X				
		2) Other than those results < MQL, were all other raw values bracketed by calibration standards?	X				
		3) Were calculations checked by a peer or supervisor?	X				
		4) Were all analyte identifications checked by a peer or supervisor?	X				
		5) Were sample detection limits reported for all analytes not detected?	X				
		6) Were all results for soil and sediment samples reported on a dry weight basis?	X				
		7) Were % moisture (or solids) reported for all soil and sediment samples?	X				
		8) Were bulk soils/solids samples for volatile analysis extracted with methanol per EPA Method 5035?			X		
		9) If required for the project, TICs reported?			X		
R4	O	Surrogate Recovery Data					
		1) Were surrogates added prior to extraction?	X				
		2) Were surrogate percent recoveries in all samples within the laboratory QC limits?		X			R4-02
R5	OI	Test Reports/Summary Forms for Blank Samples					
		1) Were appropriate type(s) of blanks analyzed?	X				
		2) Were blanks analyzed at the appropriate frequency?	X				
		3) Where method blanks taken through the entire analytical process, including preparation and, if applicable, cleanup procedures?	X				
		4) Were blank concentrations < MQL?	X				
R6	OI	Laboratory Control Samples (LCS):					
		1) Were all COCs included in the LCS?	X				
		2) Was each LCS taken through the entire analytical procedure, including prep and cleanup steps?	X				
		3) Were LCSs analyzed at the required frequency?	X				
		4) Were LCS (and LCSD, if applicable) %Rs within the laboratory QC limits?	X				
		5) Does the detectability data document the laboratory's capability to detect the COCs at the MDL used to calculate the SDLs?	X				
		6) Was the LCSD RPD within QC limits (if applicable)?	X				
R7	OI	Matrix Spike (MS) and Matrix Spike Duplicate (MSD) Data					
		1) Were the project/method specified analytes included in the MS and MSD?	X				
		2) Were MS/MSD analyzed at the appropriate frequency?	X				
		3) Were MS (and MSD, if applicable) %Rs within the laboratory QC limits?		X			R7-03
		4) Were MS/MSD RPDs within laboratory QC limits?		X			R7-04
R8	OI	Analytical Duplicate Data					
		1) Were appropriate analytical duplicates analyzed for each matrix?	X				
		2) Were analytical duplicates analyzed at the appropriate frequency?	X				
		3) Were RPDs or relative standard deviations within the laboratory QC limits?	X				
R9	OI	Method Quantitation Limits (MQLs):					
		1) Are the MQLs for each method analyte included in the laboratory data package?	X				
		2) Do the MQLs correspond to the concentration of the lowest non-zero calibration standard?	X				
		3) Are unadjusted MQLs and DCSs included in the laboratory data package?	X				
R10	OI	Other Problems/Anomalies					
		1) Are all known problems/anomalies/special conditions noted in this LRC and ER?	X				R10-01
		2) Was applicable and available technology used to lower the SDL to minimize the matrix interference affects on the sample results?	X				
		3) Is the laboratory NELAC-accredited under the Texas Laboratory Accreditation Program for the analytes, matrices and methods associated with this laboratory data package?	X				

1 Items identified by the letter "R" should be included in the laboratory data package submitted to the TCEQ in the TRRP-required report(s). Items identified by the letter "S" should be retained and made available upon request for the appropriate retention period.

2 O = organic analyses; I = inorganic analyses (and general chemistry, when applicable).

3 NA = Not applicable.

4 NR = Not Reviewed.

5 ER# = Exception Report identification number (an Exception Report should be completed for an item if "NR" or "No" is checked).

DHL Analytical, Inc.							
Laboratory Review Checklist (continued): Supporting Data							
Project Name: Winnwood Ponds - Addison				Date: 6/2/14			
Reviewer Name: Carlos Castro				Laboratory Work Order: 1405176			
# ¹	A ²	Description	Yes	No	NA ³	NR ⁴	ER# ⁵
S1	OI	Initial Calibration (ICAL)					
		1) Were response factors and/or relative response factors for each analyte within QC limits?	X				
		2) Were percent RSDs or correlation coefficient criteria met?	X				
		3) Was the number of standards recommended in the method used for all analytes?	X				
		4) Were all points generated between the lowest and highest standard used to calculate the curve?	X				
		5) Are ICAL data available for all instruments used?	X				
		6) Has the initial calibration curve been verified using an appropriate second source standard?	X				
S2	OI	Initial and Continuing calibration Verification (ICCV and CCV) and Continuing Calibration blank (CCB):					
		1) Was the CCV analyzed at the method-required frequency?	X				
		2) Were percent differences for each analyte within the method-required QC limits?		X			S2-02
		3) Was the ICAL curve verified for each analyte?	X				
		4) Was the absolute value of the analyte concentration in the inorganic CCB < MDL?	X				
S3	O	Mass Spectral Tuning:					
		1) Was the appropriate compound for the method used for tuning?	X				
		2) Were ion abundance data within the method-required QC limits?	X				
S4	O	Internal Standards (IS):					
		1) Were IS area counts and retention times within the method-required QC limits?	X				
S5	OI	Raw Data (NELAC Section 5.5.10)					
		1) Were the raw data (for example, chromatograms, spectral data) reviewed by an analyst?	X				
		2) Were data associated with manual integrations flagged on the raw data?	X				
S6	O	Dual Column Confirmation					
		1) Did dual column confirmation results meet the method-required QC?			X		
S7	O	Tentatively Identified Compounds (TICs):					
		1) If TICs were requested, were the mass spectra and TIC data subject to appropriate checks?			X		
S8	I	Interference Check Sample (ICS) Results:					
		1) Were percent recoveries within method QC limits?	X				
S9	I	Serial Dilutions, Post Digestion Spikes, and Method of Standard Additions					
		1) Were percent differences, recoveries, and the linearity within the QC limits specified in the method?		X			S9-01
S10	OI	Method Detection Limit (MDL) Studies					
		1) Was a MDL study performed for each reported analyte?	X				
		2) Is the MDL either adjusted or supported by the analysis of DCSSs?	X				
S11	OI	Proficiency Test Reports:					
		1) Was the lab's performance acceptable on the applicable proficiency tests or evaluation studies?	X				
S12	OI	Standards Documentation					
		1) Are all standards used in the analyses NIST-traceable or obtained from other appropriate sources?	X				
S13	OI	Compound/Analyte Identification Procedures					
		1) Are the procedures for compound/analyte identification documented?	X				
S14	OI	Demonstration of Analyst Competency (DOC)					
		1) Was DOC conducted consistent with NELAC Chapter 5 – Appendix C?	X				
		2) Is documentation of the analyst's competency up-to-date and on file?	X				
S15	OI	Verification/Validation Documentation for Methods (NELAC Chapter 5)					
		1) Are all the methods used to generate the data documented, verified, and validated, where applicable?	X				
S16	OI	Laboratory Standard Operating Procedures (SOPs):					
		1) Are laboratory SOPs current and on file for each method performed?	X				

1 Items identified by the letter "R" should be included in the laboratory data package submitted to the TCEQ in the TRRP-required report(s). Items identified by the letter "S" should be retained and made available upon request for the appropriate retention period.

2 O = organic analyses; I = inorganic analyses (and general chemistry, when applicable).

3 NA = Not applicable.

4 NR = Not Reviewed.

5 ER# = Exception Report identification number (an Exception Report should be completed for an item if "NR" or "No" is checked).

Laboratory Data Package Signature Page – RG-366/TRRP-13

This data package consists of:

This signature page, the laboratory review checklist, and the following reportable data:

- R1 Field chain-of-custody documentation;
- R2 Sample identification cross-reference;
- R3 Test reports (analytical data sheets) for each environmental sample that includes:
 - a) Items consistent with NELAC Chapter 5,
 - b) dilution factors,
 - c) preparation methods,
 - d) cleanup methods, and
 - e) if required for the project, tentatively identified compounds (TICs).
- R4 Surrogate recovery data including:
 - a) Calculated recovery (%R), and
 - b) The laboratory's surrogate QC limits.
- R5 Test reports/summary forms for blank samples;
- R6 Test reports/summary forms for laboratory control samples (LCSs) including:
 - a) LCS spiking amounts,
 - b) Calculated %R for each analyte, and
 - c) The laboratory's LCS QC limits.
- R7 Test reports for project matrix spike/matrix spike duplicates (MS/MSDs) including:
 - a) Samples associated with the MS/MSD clearly identified,
 - b) MS/MSD spiking amounts,
 - c) Concentration of each MS/MSD analyte measured in the parent and spiked samples,
 - d) Calculated %Rs and relative percent differences (RPDs), and
 - e) The laboratory's MS/MSD QC limits
- R8 Laboratory analytical duplicate (if applicable) recovery and precision:
 - a) The amount of analyte measured in the duplicate,
 - b) The calculated RPD, and
 - c) The laboratory's QC limits for analytical duplicates.
- R9 List of method quantitation limits (MQLs) and detectability check sample results for each analyte for each method and matrix;
- R10 Other problems or anomalies.

The Exception Report for every "No" or "Not Reviewed (NR)" item in Laboratory Review checklist and for each analyte, matrix, and method for which the laboratory does not hold NELAC accreditation under the Texas Laboratory Accreditation Program.

Release Statement: I am responsible for the release of this laboratory data package. This laboratory is NELAC accredited under the Texas Laboratory Accreditation Program for all the methods, analytes, and matrices reported in this data package except as noted in the Exception Reports. The data have been reviewed and are technically compliant with the requirements of the methods used, except where noted by the laboratory in the Exception Reports. By my signature below, I affirm to the best of my knowledge that all problems/anomalies observed by the laboratory have been identified in the Laboratory Review Checklist, and no information or data affecting the quality of the data has been knowingly withheld.

This laboratory was last inspected by TCEQ on May 6-10, 2013. Any findings affecting the data in this laboratory data package are noted in the Exception Reports herein. The official signing the cover page of the report in which these data are used is responsible for releasing this data package and is by signature affirming the above release statement is true.

John DuPont – General Manager

Scott Schroeder – Technical Director

Signature

06/02/14
Date

CLIENT: Halff Associates, Inc
Project: Winnwood Ponds - Addison
Lab Order: 1405176

CASE NARRATIVE

The samples were analyzed using the methods outlined in the following references:

Method SW8270D - Semivolatile Organics
Method SW8270D - Pesticide Analysis
Method SW8270D - PCB Analysis
Method SW6020A - Metals Analysis
Method SW7471B - Mercury Analysis
Method D2216 - Percent Moisture Analysis

Exception Report R1-01

The samples were received and log-in performed on 5/15/14. A total of 3 samples were received. The samples arrived in good condition and were properly packaged.

Exception Report R4-02

For Semivolatiles analysis performed on 5/27/14 the surrogate recoveries for the method blank and matrix spike duplicate were slightly above control limits for Nitrobenzene-d5 or 4-Terphenyl-d14. These are flagged accordingly in the QC summary report. The remaining surrogates were within control limits. No further corrective actions were taken.

Exception Report R7-03 & R7-04

For Semivolatiles analysis performed on 5/27/14 the matrix spike and matrix spike duplicate (1405185-09 MS/MSD) had the RPD slightly above control limits for Dibenz[a,h]anthracene. This is flagged accordingly in the QC summary report. The sample selected for the matrix spike and matrix spike duplicate was not from this work order. The percent recovery was within control limits for this compound. No further corrective actions were taken.

For Pesticide analysis performed on 5/27/14 the matrix spike and matrix spike duplicate recoveries (1405163-04 MS/MSD) were below control limits for 4,4'-DDE and/or Endosulfan II. These are flagged accordingly. The sample selected for the matrix spike and matrix spike duplicate was not from this work order. The LCS was within control limits for these compounds. No further corrective actions were taken.

For Metals analysis performed on 5/27/14 the matrix spike and matrix spike duplicate recoveries (1405109-08 MS/MSD) were out of control limits for three analytes. These are flagged accordingly. The sample selected for the matrix spike and matrix spike duplicate was not from this work order. The LCS was within control limits for these analytes. No further corrective actions were taken.

CLIENT: Halff Associates, Inc
Project: Winnwood Ponds - Addison
Lab Order: 1405176

CASE NARRATIVE

Exception Report R10-01

For Semivolatiles analysis, Pesticide analysis, and PCB analysis samples SD-1, SD-2 and SD-3 were diluted prior to analysis due to the nature of the samples (concentration of non-target compounds or color of the extract).

Exception Report S2-02

For Pesticide analysis, the recoveries of two compounds for the Initial Verification Calibration (ICV-140527) were slightly above the method control limits specified in SW8260C (80-120% recovery). These are flagged accordingly in the QC summary report. The number of target compounds outside of the method control limits for the ICV are less than 20% of the total number of compounds being reported; this is allowed in SW8260C specifications. These compounds were within method control limits in the LCS. No further corrective actions were taken.

Exception Report S9-01

For Metals analysis performed on 5/27/14 the PDS recovery was above control limits for Copper. This is flagged accordingly in the QC summary report. The serial dilution was within control limits for this analyte. No further corrective actions were taken.

For Metals analysis performed on 5/27/14 the RPD for the serial dilution was above control limits for Selenium. This is flagged accordingly. The PDS was within control limits for this analyte. No further corrective actions were taken.

CLIENT: Halff Associates, Inc
Project: Winnwood Ponds - Addison
Lab Order: 1405176

Work Order Sample Summary

Lab Smp ID	Client Sample ID	Tag Number	Date Collected	Date Recved
1405176-01	SD-1		05/14/14 02:20 PM	5/15/2014
1405176-02	SD-2		05/14/14 12:30 PM	5/15/2014
1405176-03	SD-3		05/14/14 11:30 AM	5/15/2014

Lab Order: 1405176
Client: Halff Associates, Inc
Project: Winnwood Ponds - Addison

PREP DATES REPORT

Sample ID	Client Sample ID	Collection Date	Matrix	Test Number	Test Name	Prep Date	Batch ID
1405176-01A	SD-1	05/14/14 02:20 PM	Sediment	SW7471A	Mercury Soil Prep, Total	05/23/14 08:00 AM	63756
	SD-1	05/14/14 02:20 PM	Sediment	SW3050B	Soil Prep Total Metals: ICP-MS	05/23/14 08:00 AM	63755
1405176-01B	SD-1	05/14/14 02:20 PM	Sediment	SW3550C	Soil Prep Sonication: BNA	05/22/14 08:14 AM	63726
	SD-1	05/14/14 02:20 PM	Sediment	SW3550C	Soil Prep Sonication: PCB	05/22/14 08:27 AM	63727
	SD-1	05/14/14 02:20 PM	Sediment	SW3550C	Soil Prep Sonication: Pest	05/22/14 02:28 PM	63748
1405176-01C	SD-1	05/14/14 02:20 PM	Sediment	D2216	Moisture Preparation	05/25/14 12:00 PM	63769
1405176-02A	SD-2	05/14/14 12:30 PM	Sediment	SW7471A	Mercury Soil Prep, Total	05/23/14 08:00 AM	63756
	SD-2	05/14/14 12:30 PM	Sediment	SW3050B	Soil Prep Total Metals: ICP-MS	05/23/14 08:00 AM	63755
1405176-02B	SD-2	05/14/14 12:30 PM	Sediment	SW3550C	Soil Prep Sonication: BNA	05/22/14 08:14 AM	63726
	SD-2	05/14/14 12:30 PM	Sediment	SW3550C	Soil Prep Sonication: PCB	05/22/14 08:27 AM	63727
	SD-2	05/14/14 12:30 PM	Sediment	SW3550C	Soil Prep Sonication: Pest	05/22/14 02:28 PM	63748
1405176-02C	SD-2	05/14/14 12:30 PM	Sediment	D2216	Moisture Preparation	05/25/14 12:00 PM	63769
1405176-03A	SD-3	05/14/14 11:30 AM	Sediment	SW7471A	Mercury Soil Prep, Total	05/23/14 08:00 AM	63756
	SD-3	05/14/14 11:30 AM	Sediment	SW3050B	Soil Prep Total Metals: ICP-MS	05/23/14 08:00 AM	63755
1405176-03B	SD-3	05/14/14 11:30 AM	Sediment	SW3550C	Soil Prep Sonication: BNA	05/22/14 08:14 AM	63726
	SD-3	05/14/14 11:30 AM	Sediment	SW3550C	Soil Prep Sonication: PCB	05/22/14 08:27 AM	63727
	SD-3	05/14/14 11:30 AM	Sediment	SW3550C	Soil Prep Sonication: Pest	05/22/14 02:28 PM	63748
1405176-03C	SD-3	05/14/14 11:30 AM	Sediment	D2216	Moisture Preparation	05/25/14 12:00 PM	63769

Lab Order: 1405176
 Client: Half Associates, Inc
 Project: Winnwood Ponds - Addison

ANALYTICAL DATES REPORT

Sample ID	Client Sample ID	Matrix	Test Number	Test Name	Batch ID	Dilution	Analysis Date	Run ID
1405176-01A	SD-1	Sediment	SW7471B	Total Mercury: Soil/Solid	63756	1	05/27/14 11:47 AM	CETAC2_HG_140527 A
	SD-1	Sediment	SW6020A	Trace Metals: ICP-MS - Solid	63755	5	05/27/14 08:12 PM	ICP-MS3_140527A
1405176-01B	SD-1	Sediment	SW8270D	PCB by GC/MS - Soil/Solid	63727	5	05/22/14 07:37 PM	GCMS8_140522A
	SD-1	Sediment	SW8270D	Pesticide by GC/MS -Soil	63748	5	05/28/14 12:26 AM	GCMS10_140527A
	SD-1	Sediment	SW8270D	Semivolatiles by GC/MS - Soil	63726	5	05/27/14 07:08 PM	GCMS9_140527A
1405176-01C	SD-1	Sediment	D2216	Percent Moisture	63769	1	05/26/14 10:12 AM	PMOIST_140525F
1405176-02A	SD-2	Sediment	SW7471B	Total Mercury: Soil/Solid	63756	1	05/27/14 11:54 AM	CETAC2_HG_140527 A
	SD-2	Sediment	SW6020A	Trace Metals: ICP-MS - Solid	63755	5	05/27/14 08:18 PM	ICP-MS3_140527A
1405176-02B	SD-2	Sediment	SW8270D	PCB by GC/MS - Soil/Solid	63727	5	05/22/14 08:08 PM	GCMS8_140522A
	SD-2	Sediment	SW8270D	Pesticide by GC/MS -Soil	63748	5	05/28/14 12:57 AM	GCMS10_140527A
	SD-2	Sediment	SW8270D	Semivolatiles by GC/MS - Soil	63726	5	05/27/14 07:32 PM	GCMS9_140527A
1405176-02C	SD-2	Sediment	D2216	Percent Moisture	63769	1	05/26/14 10:12 AM	PMOIST_140525F
1405176-03A	SD-3	Sediment	SW7471B	Total Mercury: Soil/Solid	63756	1	05/27/14 11:56 AM	CETAC2_HG_140527 A
	SD-3	Sediment	SW6020A	Trace Metals: ICP-MS - Solid	63755	5	05/27/14 08:24 PM	ICP-MS3_140527A
1405176-03B	SD-3	Sediment	SW8270D	PCB by GC/MS - Soil/Solid	63727	5	05/22/14 08:39 PM	GCMS8_140522A
	SD-3	Sediment	SW8270D	Pesticide by GC/MS -Soil	63748	5	05/28/14 01:28 AM	GCMS10_140527A
	SD-3	Sediment	SW8270D	Semivolatiles by GC/MS - Soil	63726	5	05/27/14 07:55 PM	GCMS9_140527A
1405176-03C	SD-3	Sediment	D2216	Percent Moisture	63769	1	05/26/14 10:12 AM	PMOIST_140525F

DHL Analytical, Inc.

Date: 02-Jun-14

CLIENT: Half Associates, Inc
Project: Winnwood Ponds - Addison
Project No:
Lab Order: 1405176

Client Sample ID: SD-1
Lab ID: 1405176-01
Collection Date: 05/14/14 02:20 PM
Matrix: SEDIMENT

Analyses	Result	SDL	RL	Qual	Units	DF	Date Analyzed
TOTAL MERCURY: SOIL/SOLID		SW7471B			Analyst: SM		
Mercury	0.0705	0.0163	0.0407		mg/Kg-dry	1	05/27/14 11:47 AM
TRACE METALS: ICP-MS - SOLID		SW6020A			Analyst: SW		
Arsenic	7.99	0.593	1.19		mg/Kg-dry	5	05/27/14 08:12 PM
Cadmium	0.712	0.119	0.356		mg/Kg-dry	5	05/27/14 08:12 PM
Chromium	29.2	0.593	2.37		mg/Kg-dry	5	05/27/14 08:12 PM
Copper	35.7	0.593	2.37		mg/Kg-dry	5	05/27/14 08:12 PM
Lead	45.1	0.119	0.356		mg/Kg-dry	5	05/27/14 08:12 PM
Nickel	24.6	0.593	2.37		mg/Kg-dry	5	05/27/14 08:12 PM
Selenium	4.08	0.178	0.593		mg/Kg-dry	5	05/27/14 08:12 PM
Silver	<0.119	0.119	0.237		mg/Kg-dry	5	05/27/14 08:12 PM
Zinc	241	1.19	2.97		mg/Kg-dry	5	05/27/14 08:12 PM
SEMIVOLATILES BY GC/MS - SOIL		SW8270D			Analyst: KL		
Acenaphthene	0.116	0.116	0.308	J	mg/Kg-dry	5	05/27/14 07:08 PM
Acenaphthylene	<0.116	0.116	0.308		mg/Kg-dry	5	05/27/14 07:08 PM
Anthracene	0.618	0.116	0.308		mg/Kg-dry	5	05/27/14 07:08 PM
Benzo[a]anthracene	3.10	0.116	0.308		mg/Kg-dry	5	05/27/14 07:08 PM
Benzo[a]pyrene	3.80	0.116	0.308		mg/Kg-dry	5	05/27/14 07:08 PM
Benzo[b]fluoranthene	4.52	0.116	0.308		mg/Kg-dry	5	05/27/14 07:08 PM
Benzo[g,h,i]perylene	2.42	0.116	0.308		mg/Kg-dry	5	05/27/14 07:08 PM
Benzo[k]fluoranthene	2.91	0.116	0.308		mg/Kg-dry	5	05/27/14 07:08 PM
Chrysene	4.38	0.116	0.308		mg/Kg-dry	5	05/27/14 07:08 PM
Dibenz[a,h]anthracene	0.757	0.116	0.308		mg/Kg-dry	5	05/27/14 07:08 PM
Fluoranthene	8.05	0.116	0.308		mg/Kg-dry	5	05/27/14 07:08 PM
Fluorene	0.170	0.116	0.308	J	mg/Kg-dry	5	05/27/14 07:08 PM
Indeno[1,2,3-cd]pyrene	2.25	0.116	0.308		mg/Kg-dry	5	05/27/14 07:08 PM
Naphthalene	<0.116	0.116	0.308		mg/Kg-dry	5	05/27/14 07:08 PM
Phenanthrene	3.22	0.116	0.308		mg/Kg-dry	5	05/27/14 07:08 PM
Pyrene	7.57	0.116	0.308		mg/Kg-dry	5	05/27/14 07:08 PM
Surr: 2-Fluorobiphenyl	115	0	60-125		%REC	5	05/27/14 07:08 PM
Surr: 4-Terphenyl-d14	105	0	45-125		%REC	5	05/27/14 07:08 PM
Surr: Nitrobenzene-d5	110	0	45-125		%REC	5	05/27/14 07:08 PM
PESTICIDE BY GC/MS -SOIL		SW8270D			Analyst: KL		
4,4'-DDD	<0.0240	0.0240	0.0721		mg/Kg-dry	5	05/28/14 12:26 AM
4,4'-DDE	<0.0240	0.0240	0.0721		mg/Kg-dry	5	05/28/14 12:26 AM
4,4'-DDT	<0.0240	0.0240	0.0721		mg/Kg-dry	5	05/28/14 12:26 AM
Aldrin	<0.0240	0.0240	0.0721		mg/Kg-dry	5	05/28/14 12:26 AM
alpha-BHC	<0.0240	0.0240	0.0721		mg/Kg-dry	5	05/28/14 12:26 AM

Qualifiers: ND - Not Detected at the SDL
 J - Analyte detected between SDL and RL
 B - Analyte detected in the associated Method Blank
 DF- Dilution Factor
 N - Parameter not NELAC certified
 See Final Page of Report for MQLs and MDLs

S - Spike Recovery outside control limits
 C - Sample Result or QC discussed in Case Narrative
 RL - Reporting Limit (MQL adjusted for moisture and sample size)
 SDL - Sample Detection Limit
 E - TPH pattern not Gas or Diesel Range Pattern

DHL Analytical, Inc.

Date: 02-Jun-14

CLIENT: Halff Associates, Inc
Project: Winnwood Ponds - Addison
Project No:
Lab Order: 1405176

Client Sample ID: SD-1
Lab ID: 1405176-01
Collection Date: 05/14/14 02:20 PM
Matrix: SEDIMENT

Analyses	Result	SDL	RL	Qual	Units	DF	Date Analyzed
PESTICIDE BY GC/MS -SOIL		SW8270D			Analyst: KL		
alpha-Chlordane	<0.0240	0.0240	0.0721		mg/Kg-dry	5	05/28/14 12:26 AM
beta-BHC	<0.0240	0.0240	0.0721		mg/Kg-dry	5	05/28/14 12:26 AM
Chlordane	<0.120	0.120	0.360		mg/Kg-dry	5	05/28/14 12:26 AM
delta-BHC	<0.0240	0.0240	0.0721		mg/Kg-dry	5	05/28/14 12:26 AM
Dieldrin	<0.0240	0.0240	0.0721		mg/Kg-dry	5	05/28/14 12:26 AM
Endosulfan I	<0.0240	0.0240	0.0721		mg/Kg-dry	5	05/28/14 12:26 AM
Endosulfan II	<0.0240	0.0240	0.0721		mg/Kg-dry	5	05/28/14 12:26 AM
Endosulfan sulfate	<0.0240	0.0240	0.0721		mg/Kg-dry	5	05/28/14 12:26 AM
Endrin	<0.0240	0.0240	0.0721		mg/Kg-dry	5	05/28/14 12:26 AM
Endrin aldehyde	<0.0240	0.0240	0.0721		mg/Kg-dry	5	05/28/14 12:26 AM
Endrin ketone	<0.0240	0.0240	0.0721		mg/Kg-dry	5	05/28/14 12:26 AM
gamma-BHC	<0.0240	0.0240	0.0721		mg/Kg-dry	5	05/28/14 12:26 AM
gamma-Chlordane	<0.0240	0.0240	0.0721		mg/Kg-dry	5	05/28/14 12:26 AM
Heptachlor	<0.0240	0.0240	0.0721		mg/Kg-dry	5	05/28/14 12:26 AM
Heptachlor epoxide	<0.0240	0.0240	0.0721		mg/Kg-dry	5	05/28/14 12:26 AM
Methoxychlor	<0.0240	0.0240	0.601		mg/Kg-dry	5	05/28/14 12:26 AM
Toxaphene	<0.961	0.961	3.00		mg/Kg-dry	5	05/28/14 12:26 AM
Surr: 2-Fluorobiphenyl	86.7	0	43-125		%REC	5	05/28/14 12:26 AM
Surr: 4-Terphenyl-d14	95.2	0	32-125		%REC	5	05/28/14 12:26 AM
PCB BY GC/MS - SOIL/SOLID		SW8270D			Analyst: KL		
Aroclor 1016	<0.193	0.193	0.386		mg/Kg-dry	5	05/22/14 07:37 PM
Aroclor 1221	<0.193	0.193	0.386		mg/Kg-dry	5	05/22/14 07:37 PM
Aroclor 1232	<0.193	0.193	0.386		mg/Kg-dry	5	05/22/14 07:37 PM
Aroclor 1242	<0.193	0.193	0.386		mg/Kg-dry	5	05/22/14 07:37 PM
Aroclor 1248	<0.193	0.193	0.386		mg/Kg-dry	5	05/22/14 07:37 PM
Aroclor 1254	<0.193	0.193	0.386		mg/Kg-dry	5	05/22/14 07:37 PM
Aroclor 1260	<0.193	0.193	0.386		mg/Kg-dry	5	05/22/14 07:37 PM
Surr: 2-Fluorobiphenyl	103	0	43-125		%REC	5	05/22/14 07:37 PM
Surr: 4-Terphenyl-d14	109	0	32-125		%REC	5	05/22/14 07:37 PM
PERCENT MOISTURE		D2216			Analyst: JL		
Percent Moisture	58.9	0	0		WT%	1	05/26/14 10:12 AM

Qualifiers: ND - Not Detected at the SDL
 J - Analyte detected between SDL and RL
 B - Analyte detected in the associated Method Blank
 DF- Dilution Factor
 N - Parameter not NELAC certified
 See Final Page of Report for MQLs and MDLs

S - Spike Recovery outside control limits
 C - Sample Result or QC discussed in Case Narrative
 RL - Reporting Limit (MQL adjusted for moisture and sample size)
 SDL - Sample Detection Limit
 E - TPH pattern not Gas or Diesel Range Pattern

DHL Analytical, Inc.

Date: 02-Jun-14

CLIENT: Half Associates, Inc
Project: Winnwood Ponds - Addison
Project No:
Lab Order: 1405176

Client Sample ID: SD-2
Lab ID: 1405176-02
Collection Date: 05/14/14 12:30 PM
Matrix: SEDIMENT

Analyses	Result	SDL	RL	Qual	Units	DF	Date Analyzed
TOTAL MERCURY: SOIL/SOLID		SW7471B			Analyst: SM		
Mercury	0.0964	0.0354	0.0884		mg/Kg-dry	1	05/27/14 11:54 AM
TRACE METALS: ICP-MS - SOLID		SW6020A			Analyst: SW		
Arsenic	10.9	1.20	2.39		mg/Kg-dry	5	05/27/14 08:18 PM
Cadmium	0.930	0.239	0.718		mg/Kg-dry	5	05/27/14 08:18 PM
Chromium	44.6	1.20	4.78		mg/Kg-dry	5	05/27/14 08:18 PM
Copper	88.0	1.20	4.78		mg/Kg-dry	5	05/27/14 08:18 PM
Lead	43.3	0.239	0.718		mg/Kg-dry	5	05/27/14 08:18 PM
Nickel	32.7	1.20	4.78		mg/Kg-dry	5	05/27/14 08:18 PM
Selenium	5.11	0.359	1.20		mg/Kg-dry	5	05/27/14 08:18 PM
Silver	<0.239	0.239	0.478		mg/Kg-dry	5	05/27/14 08:18 PM
Zinc	497	2.39	5.98		mg/Kg-dry	5	05/27/14 08:18 PM
SEMIVOLATILES BY GC/MS - SOIL		SW8270D			Analyst: KL		
Acenaphthene	<0.232	0.232	0.617		mg/Kg-dry	5	05/27/14 07:32 PM
Acenaphthylene	<0.232	0.232	0.617		mg/Kg-dry	5	05/27/14 07:32 PM
Anthracene	<0.232	0.232	0.617		mg/Kg-dry	5	05/27/14 07:32 PM
Benzo[a]anthracene	1.42	0.232	0.617		mg/Kg-dry	5	05/27/14 07:32 PM
Benzo[a]pyrene	2.12	0.232	0.617		mg/Kg-dry	5	05/27/14 07:32 PM
Benzo[b]fluoranthene	2.77	0.232	0.617		mg/Kg-dry	5	05/27/14 07:32 PM
Benzo[g,h,i]perylene	2.32	0.232	0.617		mg/Kg-dry	5	05/27/14 07:32 PM
Benzo[k]fluoranthene	2.02	0.232	0.617		mg/Kg-dry	5	05/27/14 07:32 PM
Chrysene	2.64	0.232	0.617		mg/Kg-dry	5	05/27/14 07:32 PM
Dibenz[a,h]anthracene	0.618	0.232	0.617		mg/Kg-dry	5	05/27/14 07:32 PM
Fluoranthene	5.11	0.232	0.617		mg/Kg-dry	5	05/27/14 07:32 PM
Fluorene	<0.232	0.232	0.617		mg/Kg-dry	5	05/27/14 07:32 PM
Indeno[1,2,3-cd]pyrene	1.99	0.232	0.617		mg/Kg-dry	5	05/27/14 07:32 PM
Naphthalene	<0.232	0.232	0.617		mg/Kg-dry	5	05/27/14 07:32 PM
Phenanthrene	1.16	0.232	0.617		mg/Kg-dry	5	05/27/14 07:32 PM
Pyrene	3.38	0.232	0.617		mg/Kg-dry	5	05/27/14 07:32 PM
Surr: 2-Fluorobiphenyl	90.0	0	60-125		%REC	5	05/27/14 07:32 PM
Surr: 4-Terphenyl-d14	90.0	0	45-125		%REC	5	05/27/14 07:32 PM
Surr: Nitrobenzene-d5	90.0	0	45-125		%REC	5	05/27/14 07:32 PM
PESTICIDE BY GC/MS -SOIL		SW8270D			Analyst: KL		
4,4'-DDD	<0.0444	0.0444	0.133		mg/Kg-dry	5	05/28/14 12:57 AM
4,4'-DDE	<0.0444	0.0444	0.133		mg/Kg-dry	5	05/28/14 12:57 AM
4,4'-DDT	0.0532	0.0444	0.133	J	mg/Kg-dry	5	05/28/14 12:57 AM
Aldrin	<0.0444	0.0444	0.133		mg/Kg-dry	5	05/28/14 12:57 AM
alpha-BHC	<0.0444	0.0444	0.133		mg/Kg-dry	5	05/28/14 12:57 AM

Qualifiers: ND - Not Detected at the SDL
 J - Analyte detected between SDL and RL
 B - Analyte detected in the associated Method Blank
 DF- Dilution Factor
 N - Parameter not NELAC certified
 See Final Page of Report for MQLs and MDLs

S - Spike Recovery outside control limits
 C - Sample Result or QC discussed in Case Narrative
 RL - Reporting Limit (MQL adjusted for moisture and sample size)
 SDL - Sample Detection Limit
 E - TPH pattern not Gas or Diesel Range Pattern

DHL Analytical, Inc.

Date: 02-Jun-14

CLIENT: Half Associates, Inc
Project: Winnwood Ponds - Addison
Project No:
Lab Order: 1405176

Client Sample ID: SD-2
Lab ID: 1405176-02
Collection Date: 05/14/14 12:30 PM
Matrix: SEDIMENT

Analyses	Result	SDL	RL	Qual	Units	DF	Date Analyzed
PESTICIDE BY GC/MS -SOIL		SW8270D			Analyst: KL		
alpha-Chlordane	<0.0444	0.0444	0.133		mg/Kg-dry	5	05/28/14 12:57 AM
beta-BHC	<0.0444	0.0444	0.133		mg/Kg-dry	5	05/28/14 12:57 AM
Chlordane	<0.222	0.222	0.665		mg/Kg-dry	5	05/28/14 12:57 AM
delta-BHC	<0.0444	0.0444	0.133		mg/Kg-dry	5	05/28/14 12:57 AM
Dieldrin	<0.0444	0.0444	0.133		mg/Kg-dry	5	05/28/14 12:57 AM
Endosulfan I	<0.0444	0.0444	0.133		mg/Kg-dry	5	05/28/14 12:57 AM
Endosulfan II	<0.0444	0.0444	0.133		mg/Kg-dry	5	05/28/14 12:57 AM
Endosulfan sulfate	<0.0444	0.0444	0.133		mg/Kg-dry	5	05/28/14 12:57 AM
Endrin	<0.0444	0.0444	0.133		mg/Kg-dry	5	05/28/14 12:57 AM
Endrin aldehyde	<0.0444	0.0444	0.133		mg/Kg-dry	5	05/28/14 12:57 AM
Endrin ketone	<0.0444	0.0444	0.133		mg/Kg-dry	5	05/28/14 12:57 AM
gamma-BHC	<0.0444	0.0444	0.133		mg/Kg-dry	5	05/28/14 12:57 AM
gamma-Chlordane	<0.0444	0.0444	0.133		mg/Kg-dry	5	05/28/14 12:57 AM
Heptachlor	<0.0444	0.0444	0.133		mg/Kg-dry	5	05/28/14 12:57 AM
Heptachlor epoxide	<0.0444	0.0444	0.133		mg/Kg-dry	5	05/28/14 12:57 AM
Methoxychlor	<0.0444	0.0444	1.11		mg/Kg-dry	5	05/28/14 12:57 AM
Toxaphene	<1.77	1.77	5.54		mg/Kg-dry	5	05/28/14 12:57 AM
Surr: 2-Fluorobiphenyl	87.4	0	43-125		%REC	5	05/28/14 12:57 AM
Surr: 4-Terphenyl-d14	96.1	0	32-125		%REC	5	05/28/14 12:57 AM
PCB BY GC/MS - SOIL/SOLID		SW8270D			Analyst: KL		
Aroclor 1016	<0.386	0.386	0.773		mg/Kg-dry	5	05/22/14 08:08 PM
Aroclor 1221	<0.386	0.386	0.773		mg/Kg-dry	5	05/22/14 08:08 PM
Aroclor 1232	<0.386	0.386	0.773		mg/Kg-dry	5	05/22/14 08:08 PM
Aroclor 1242	<0.386	0.386	0.773		mg/Kg-dry	5	05/22/14 08:08 PM
Aroclor 1248	<0.386	0.386	0.773		mg/Kg-dry	5	05/22/14 08:08 PM
Aroclor 1254	<0.386	0.386	0.773		mg/Kg-dry	5	05/22/14 08:08 PM
Aroclor 1260	<0.386	0.386	0.773		mg/Kg-dry	5	05/22/14 08:08 PM
Surr: 2-Fluorobiphenyl	90.5	0	43-125		%REC	5	05/22/14 08:08 PM
Surr: 4-Terphenyl-d14	99.9	0	32-125		%REC	5	05/22/14 08:08 PM
PERCENT MOISTURE		D2216			Analyst: JL		
Percent Moisture	78.7	0	0		WT%	1	05/26/14 10:12 AM

Qualifiers: ND - Not Detected at the SDL
 J - Analyte detected between SDL and RL
 B - Analyte detected in the associated Method Blank
 DF- Dilution Factor
 N - Parameter not NELAC certified
 See Final Page of Report for MQLs and MDLs

S - Spike Recovery outside control limits
 C - Sample Result or QC discussed in Case Narrative
 RL - Reporting Limit (MQL adjusted for moisture and sample size)
 SDL - Sample Detection Limit
 E - TPH pattern not Gas or Diesel Range Pattern

DHL Analytical, Inc.

Date: 02-Jun-14

CLIENT: Half Associates, Inc
Project: Winnwood Ponds - Addison
Project No:
Lab Order: 1405176

Client Sample ID: SD-3
Lab ID: 1405176-03
Collection Date: 05/14/14 11:30 AM
Matrix: SEDIMENT

Analyses	Result	SDL	RL	Qual	Units	DF	Date Analyzed
TOTAL MERCURY: SOIL/SOLID		SW7471B			Analyst: SM		
Mercury	0.0960	0.0384	0.0960		mg/Kg-dry	1	05/27/14 11:56 AM
TRACE METALS: ICP-MS - SOLID		SW6020A			Analyst: SW		
Arsenic	10.2	1.24	2.48		mg/Kg-dry	5	05/27/14 08:24 PM
Cadmium	0.871	0.248	0.744		mg/Kg-dry	5	05/27/14 08:24 PM
Chromium	44.8	1.24	4.96		mg/Kg-dry	5	05/27/14 08:24 PM
Copper	91.6	1.24	4.96		mg/Kg-dry	5	05/27/14 08:24 PM
Lead	42.3	0.248	0.744		mg/Kg-dry	5	05/27/14 08:24 PM
Nickel	31.5	1.24	4.96		mg/Kg-dry	5	05/27/14 08:24 PM
Selenium	5.42	0.372	1.24		mg/Kg-dry	5	05/27/14 08:24 PM
Silver	0.309	0.248	0.496	J	mg/Kg-dry	5	05/27/14 08:24 PM
Zinc	487	2.48	6.20		mg/Kg-dry	5	05/27/14 08:24 PM
SEMIVOLATILES BY GC/MS - SOIL		SW8270D			Analyst: KL		
Acenaphthene	<0.228	0.228	0.605		mg/Kg-dry	5	05/27/14 07:55 PM
Acenaphthylene	<0.228	0.228	0.605		mg/Kg-dry	5	05/27/14 07:55 PM
Anthracene	<0.228	0.228	0.605		mg/Kg-dry	5	05/27/14 07:55 PM
Benzo[a]anthracene	1.27	0.228	0.605		mg/Kg-dry	5	05/27/14 07:55 PM
Benzo[a]pyrene	2.05	0.228	0.605		mg/Kg-dry	5	05/27/14 07:55 PM
Benzo[b]fluoranthene	3.20	0.228	0.605		mg/Kg-dry	5	05/27/14 07:55 PM
Benzo[g,h,i]perylene	2.25	0.228	0.605		mg/Kg-dry	5	05/27/14 07:55 PM
Benzo[k]fluoranthene	2.47	0.228	0.605		mg/Kg-dry	5	05/27/14 07:55 PM
Chrysene	2.67	0.228	0.605		mg/Kg-dry	5	05/27/14 07:55 PM
Dibenz[a,h]anthracene	0.652	0.228	0.605		mg/Kg-dry	5	05/27/14 07:55 PM
Fluoranthene	4.05	0.228	0.605		mg/Kg-dry	5	05/27/14 07:55 PM
Fluorene	<0.228	0.228	0.605		mg/Kg-dry	5	05/27/14 07:55 PM
Indeno[1,2,3-cd]pyrene	2.00	0.228	0.605		mg/Kg-dry	5	05/27/14 07:55 PM
Naphthalene	<0.228	0.228	0.605		mg/Kg-dry	5	05/27/14 07:55 PM
Phenanthrene	1.21	0.228	0.605		mg/Kg-dry	5	05/27/14 07:55 PM
Pyrene	2.85	0.228	0.605		mg/Kg-dry	5	05/27/14 07:55 PM
Surr: 2-Fluorobiphenyl	95.0	0	60-125		%REC	5	05/27/14 07:55 PM
Surr: 4-Terphenyl-d14	95.0	0	45-125		%REC	5	05/27/14 07:55 PM
Surr: Nitrobenzene-d5	120	0	45-125		%REC	5	05/27/14 07:55 PM
PESTICIDE BY GC/MS -SOIL		SW8270D			Analyst: KL		
4,4'-DDD	<0.0468	0.0468	0.140		mg/Kg-dry	5	05/28/14 01:28 AM
4,4'-DDE	<0.0468	0.0468	0.140		mg/Kg-dry	5	05/28/14 01:28 AM
4,4'-DDT	0.0566	0.0468	0.140	J	mg/Kg-dry	5	05/28/14 01:28 AM
Aldrin	<0.0468	0.0468	0.140		mg/Kg-dry	5	05/28/14 01:28 AM
alpha-BHC	<0.0468	0.0468	0.140		mg/Kg-dry	5	05/28/14 01:28 AM

Qualifiers: ND - Not Detected at the SDL
 J - Analyte detected between SDL and RL
 B - Analyte detected in the associated Method Blank
 DF - Dilution Factor
 N - Parameter not NELAC certified
 See Final Page of Report for MQLs and MDLs

S - Spike Recovery outside control limits
 C - Sample Result or QC discussed in Case Narrative
 RL - Reporting Limit (MQL adjusted for moisture and sample size)
 SDL - Sample Detection Limit
 E - TPH pattern not Gas or Diesel Range Pattern

DHL Analytical, Inc.

Date: 02-Jun-14

CLIENT: Half Associates, Inc
Project: Winnwood Ponds - Addison
Project No:
Lab Order: 1405176

Client Sample ID: SD-3
Lab ID: 1405176-03
Collection Date: 05/14/14 11:30 AM
Matrix: SEDIMENT

Analyses	Result	SDL	RL	Qual	Units	DF	Date Analyzed
PESTICIDE BY GC/MS -SOIL		SW8270D			Analyst: KL		
alpha-Chlordane	<0.0468	0.0468	0.140		mg/Kg-dry	5	05/28/14 01:28 AM
beta-BHC	<0.0468	0.0468	0.140		mg/Kg-dry	5	05/28/14 01:28 AM
Chlordane	<0.234	0.234	0.702		mg/Kg-dry	5	05/28/14 01:28 AM
delta-BHC	<0.0468	0.0468	0.140		mg/Kg-dry	5	05/28/14 01:28 AM
Dieldrin	<0.0468	0.0468	0.140		mg/Kg-dry	5	05/28/14 01:28 AM
Endosulfan I	<0.0468	0.0468	0.140		mg/Kg-dry	5	05/28/14 01:28 AM
Endosulfan II	<0.0468	0.0468	0.140		mg/Kg-dry	5	05/28/14 01:28 AM
Endosulfan sulfate	<0.0468	0.0468	0.140		mg/Kg-dry	5	05/28/14 01:28 AM
Endrin	<0.0468	0.0468	0.140		mg/Kg-dry	5	05/28/14 01:28 AM
Endrin aldehyde	<0.0468	0.0468	0.140		mg/Kg-dry	5	05/28/14 01:28 AM
Endrin ketone	<0.0468	0.0468	0.140		mg/Kg-dry	5	05/28/14 01:28 AM
gamma-BHC	<0.0468	0.0468	0.140		mg/Kg-dry	5	05/28/14 01:28 AM
gamma-Chlordane	<0.0468	0.0468	0.140		mg/Kg-dry	5	05/28/14 01:28 AM
Heptachlor	<0.0468	0.0468	0.140		mg/Kg-dry	5	05/28/14 01:28 AM
Heptachlor epoxide	<0.0468	0.0468	0.140		mg/Kg-dry	5	05/28/14 01:28 AM
Methoxychlor	<0.0468	0.0468	1.17		mg/Kg-dry	5	05/28/14 01:28 AM
Toxaphene	<1.87	1.87	5.85		mg/Kg-dry	5	05/28/14 01:28 AM
Surr: 2-Fluorobiphenyl	85.5	0	43-125		%REC	5	05/28/14 01:28 AM
Surr: 4-Terphenyl-d14	95.0	0	32-125		%REC	5	05/28/14 01:28 AM
PCB BY GC/MS - SOIL/SOLID		SW8270D			Analyst: KL		
Aroclor 1016	<0.379	0.379	0.759		mg/Kg-dry	5	05/22/14 08:39 PM
Aroclor 1221	<0.379	0.379	0.759		mg/Kg-dry	5	05/22/14 08:39 PM
Aroclor 1232	<0.379	0.379	0.759		mg/Kg-dry	5	05/22/14 08:39 PM
Aroclor 1242	<0.379	0.379	0.759		mg/Kg-dry	5	05/22/14 08:39 PM
Aroclor 1248	<0.379	0.379	0.759		mg/Kg-dry	5	05/22/14 08:39 PM
Aroclor 1254	<0.379	0.379	0.759		mg/Kg-dry	5	05/22/14 08:39 PM
Aroclor 1260	<0.379	0.379	0.759		mg/Kg-dry	5	05/22/14 08:39 PM
Surr: 2-Fluorobiphenyl	100	0	43-125		%REC	5	05/22/14 08:39 PM
Surr: 4-Terphenyl-d14	105	0	32-125		%REC	5	05/22/14 08:39 PM
PERCENT MOISTURE		D2216			Analyst: JL		
Percent Moisture	79.2	0	0		WT%	1	05/26/14 10:12 AM

Qualifiers: ND - Not Detected at the SDL
 J - Analyte detected between SDL and RL
 B - Analyte detected in the associated Method Blank
 DF- Dilution Factor
 N - Parameter not NELAC certified
 See Final Page of Report for MQLs and MDLs

S - Spike Recovery outside control limits
 C - Sample Result or QC discussed in Case Narrative
 RL - Reporting Limit (MQL adjusted for moisture and sample size)
 SDL - Sample Detection Limit
 E - TPH pattern not Gas or Diesel Range Pattern

CLIENT: Halff Associates, Inc
Work Order: 1405176
Project: Winnwood Ponds - Addison

ANALYTICAL QC SUMMARY REPORT

RunID: CETAC2_HG_140514C

Sample ID	DCS-63529	Batch ID:	63529	TestNo:	SW7471B	Units:	mg/Kg				
SampType:	DCS	Run ID:	CETAC2_HG_140514C	Analysis Date:	5/14/2014 2:44:09 PM	Prep Date:	5/14/2014				
Analyte		Result	RL	SPK value	Ref Val	%REC	LowLimit	HighLimit	%RPD	RPDLimit	Qual
Mercury		0.0217	0.0400	0.02000	0	108	80	120	0	0	

Qualifiers: B Analyte detected in the associated Method Blank
 J Analyte detected between MDL and RL
 ND Not Detected at the Method Detection Limit
 RL Reporting Limit
 J Analyte detected between SDL and RL

DF Dilution Factor
 MDL Method Detection Limit
 R RPD outside accepted control limits
 S Spike Recovery outside control limits
 N Parameter not NELAC certified

CLIENT: Halff Associates, Inc
Work Order: 1405176
Project: Winnwood Ponds - Addison

ANALYTICAL QC SUMMARY REPORT

RunID: CETAC2_HG_140527A

The QC data in batch 63756 applies to the following samples: 1405176-01A, 1405176-02A, 1405176-03A

Sample ID MB-63756	Batch ID: 63756	TestNo: SW7471B	Units: mg/Kg							
SampType: MBLK	Run ID: CETAC2_HG_140527A	Analysis Date: 5/27/2014 10:59:45 AM	Prep Date: 5/23/2014							
Analyte	Result	RL	SPK value	Ref Val	%REC	LowLimit	HighLimit	%RPD	RPDLimit	Qual
Mercury	<0.0160	0.0400								

Sample ID LCS-63756	Batch ID: 63756	TestNo: SW7471B	Units: mg/Kg							
SampType: LCS	Run ID: CETAC2_HG_140527A	Analysis Date: 5/27/2014 11:02:01 AM	Prep Date: 5/23/2014							
Analyte	Result	RL	SPK value	Ref Val	%REC	LowLimit	HighLimit	%RPD	RPDLimit	Qual
Mercury	0.221	0.0400	0.2000	0	110	85	115			

Sample ID LCSD-63756	Batch ID: 63756	TestNo: SW7471B	Units: mg/Kg							
SampType: LCSD	Run ID: CETAC2_HG_140527A	Analysis Date: 5/27/2014 11:04:17 AM	Prep Date: 5/23/2014							
Analyte	Result	RL	SPK value	Ref Val	%REC	LowLimit	HighLimit	%RPD	RPDLimit	Qual
Mercury	0.219	0.0400	0.2000	0	110	85	115	0.909	25	

Sample ID 1405109-08A SD	Batch ID: 63756	TestNo: SW7471B	Units: mg/Kg-dry							
SampType: SD	Run ID: CETAC2_HG_140527A	Analysis Date: 5/27/2014 11:08:50 AM	Prep Date: 5/23/2014							
Analyte	Result	RL	SPK value	Ref Val	%REC	LowLimit	HighLimit	%RPD	RPDLimit	Qual
Mercury	<0.0899	0.225	0	0.02630				0	10	

Sample ID 1405109-08A PDS	Batch ID: 63756	TestNo: SW7471B	Units: mg/Kg-dry							
SampType: PDS	Run ID: CETAC2_HG_140527A	Analysis Date: 5/27/2014 11:11:06 AM	Prep Date: 5/23/2014							
Analyte	Result	RL	SPK value	Ref Val	%REC	LowLimit	HighLimit	%RPD	RPDLimit	Qual
Mercury	0.301	0.0450	0.2810	0.02630	97.8	85	115			

Sample ID 1405109-08A MS	Batch ID: 63756	TestNo: SW7471B	Units: mg/Kg-dry							
SampType: MS	Run ID: CETAC2_HG_140527A	Analysis Date: 5/27/2014 11:13:21 AM	Prep Date: 5/23/2014							
Analyte	Result	RL	SPK value	Ref Val	%REC	LowLimit	HighLimit	%RPD	RPDLimit	Qual
Mercury	0.257	0.0430	0.2151	0.02630	107	80	120			

Sample ID 1405109-08A MSD	Batch ID: 63756	TestNo: SW7471B	Units: mg/Kg-dry							
SampType: MSD	Run ID: CETAC2_HG_140527A	Analysis Date: 5/27/2014 11:15:37 AM	Prep Date: 5/23/2014							
Analyte	Result	RL	SPK value	Ref Val	%REC	LowLimit	HighLimit	%RPD	RPDLimit	Qual
Mercury	0.246	0.0421	0.2104	0.02630	104	80	120	4.35	25	

Qualifiers: B Analyte detected in the associated Method Blank DF Dilution Factor
J Analyte detected between MDL and RL MDL Method Detection Limit
ND Not Detected at the Method Detection Limit R RPD outside accepted control limits
RL Reporting Limit S Spike Recovery outside control limits
J Analyte detected between SDL and RL N Parameter not NELAC certified

CLIENT: Halff Associates, Inc
Work Order: 1405176
Project: Winnwood Ponds - Addison

ANALYTICAL QC SUMMARY REPORT

RunID: CETAC2_HG_140527A

Sample ID ICV1-140527	Batch ID: R73345	TestNo: SW7471B	Units: mg/Kg							
SampType: ICV	Run ID: CETAC2_HG_140527A	Analysis Date: 5/27/2014 10:52:54 AM	Prep Date:							
Analyte	Result	RL	SPK value	Ref Val	%REC	LowLimit	HighLimit	%RPD	RPDLimit	Qual

Mercury	0.00424	0.0400	0.004000	0	106	90	110			
---------	---------	--------	----------	---	-----	----	-----	--	--	--

Sample ID CCV1-140527	Batch ID: R73345	TestNo: SW7471B	Units: mg/Kg							
SampType: CCV	Run ID: CETAC2_HG_140527A	Analysis Date: 5/27/2014 11:22:27 AM	Prep Date:							
Analyte	Result	RL	SPK value	Ref Val	%REC	LowLimit	HighLimit	%RPD	RPDLimit	Qual

Mercury	0.00201	0.0400	0.002000	0	101	90	110			
---------	---------	--------	----------	---	-----	----	-----	--	--	--

Sample ID CCV2-140527	Batch ID: R73345	TestNo: SW7471B	Units: mg/Kg							
SampType: CCV	Run ID: CETAC2_HG_140527A	Analysis Date: 5/27/2014 11:49:43 AM	Prep Date:							
Analyte	Result	RL	SPK value	Ref Val	%REC	LowLimit	HighLimit	%RPD	RPDLimit	Qual

Mercury	0.00206	0.0400	0.002000	0	103	90	110			
---------	---------	--------	----------	---	-----	----	-----	--	--	--

Sample ID CCV3-140527	Batch ID: R73345	TestNo: SW7471B	Units: mg/Kg							
SampType: CCV	Run ID: CETAC2_HG_140527A	Analysis Date: 5/27/2014 12:07:57 PM	Prep Date:							
Analyte	Result	RL	SPK value	Ref Val	%REC	LowLimit	HighLimit	%RPD	RPDLimit	Qual

Mercury	0.00204	0.0400	0.002000	0	102	90	110			
---------	---------	--------	----------	---	-----	----	-----	--	--	--

Qualifiers:	<p>B Analyte detected in the associated Method Blank</p> <p>J Analyte detected between MDL and RL</p> <p>ND Not Detected at the Method Detection Limit</p> <p>RL Reporting Limit</p> <p>J Analyte detected between SDL and RL</p>	<p>DF Dilution Factor</p> <p>MDL Method Detection Limit</p> <p>R RPD outside accepted control limits</p> <p>S Spike Recovery outside control limits</p> <p>N Parameter not NELAC certified</p>
--------------------	-----------------------------------------------------------------------------------------------------------------------------------------------------------------------------------------------------------------------------------	------------------------------------------------------------------------------------------------------------------------------------------------------------------------------------------------

CLIENT: Halff Associates, Inc
Work Order: 1405176
Project: Winnwood Ponds - Addison

ANALYTICAL QC SUMMARY REPORT

RunID: ICP-MS3_140327A

Sample ID: DCS-62478-1	Batch ID: 62478	TestNo: SW6020A	Units: mg/Kg
SampType: DCS	Run ID: ICP-MS3_140327A	Analysis Date: 3/27/2014 12:50:00 PM	Prep Date: 3/24/2014

Analyte	Result	RL	SPK value	Ref Val	%REC	LowLimit	HighLimit	%RPD	RPDLimit	Qual
Arsenic	0.147	1.00	0.1500	0	97.7	80	120	0	0	
Cadmium	0.152	0.300	0.1500	0	101	80	120	0	0	
Copper	0.168	2.00	0.1500	0	112	80	120	0	0	
Lead	0.156	0.300	0.1500	0	104	80	120	0	0	
Nickel	0.124	2.00	0.1500	0	82.4	80	120	0	0	
Selenium	0.143	0.500	0.1500	0	95.1	80	120	0	0	
Silver	0.141	0.200	0.1500	0	93.7	80	120	0	0	

Sample ID: DCS-62478-2	Batch ID: 62478	TestNo: SW6020A	Units: mg/Kg
SampType: DCS2	Run ID: ICP-MS3_140327A	Analysis Date: 3/27/2014 12:56:00 PM	Prep Date: 3/24/2014

Analyte	Result	RL	SPK value	Ref Val	%REC	LowLimit	HighLimit	%RPD	RPDLimit	Qual
Chromium	1.07	2.00	1.000	0	107	80	120	0	0	

Sample ID: DCS-62478-3	Batch ID: 62478	TestNo: SW6020A	Units: mg/Kg
SampType: DCS3	Run ID: ICP-MS3_140327A	Analysis Date: 3/27/2014 1:02:00 PM	Prep Date: 3/24/2014

Analyte	Result	RL	SPK value	Ref Val	%REC	LowLimit	HighLimit	%RPD	RPDLimit	Qual
Zinc	5.43	2.50	5.000	0	109	80	120	0	0	

Qualifiers: B Analyte detected in the associated Method Blank J Analyte detected between MDL and RL ND Not Detected at the Method Detection Limit RL Reporting Limit J Analyte detected between SDL and RL	DF Dilution Factor MDL Method Detection Limit R RPD outside accepted control limits S Spike Recovery outside control limits N Parameter not NELAC certified
----------------------------------------------------------------------------------------------------------------------------------------------------------------------------------------------------------------------------------	-------------------------------------------------------------------------------------------------------------------------------------------------------------------------

CLIENT: Halff Associates, Inc
Work Order: 1405176
Project: Winnwood Ponds - Addison

ANALYTICAL QC SUMMARY REPORT

RunID: ICP-MS3_140527A

The QC data in batch 63755 applies to the following samples: 1405176-01A, 1405176-02A, 1405176-03A

Sample ID MB-63755	Batch ID: 63755	TestNo: SW6020A	Units: mg/Kg							
SampType: MBLK	Run ID: ICP-MS3_140527A	Analysis Date: 5/27/2014 5:17:00 PM	Prep Date: 5/23/2014							
Analyte	Result	RL	SPK value	Ref Val	%REC	LowLimit	HighLimit	%RPD	RPDLimit	Qual

Arsenic	<0.500	1.00								
Cadmium	<0.100	0.300								
Chromium	<0.500	2.00								
Copper	<0.500	2.00								
Lead	<0.100	0.300								
Nickel	<0.500	2.00								
Selenium	<0.150	0.500								
Silver	<0.100	0.200								
Zinc	<1.00	2.50								

Sample ID LCS-63755	Batch ID: 63755	TestNo: SW6020A	Units: mg/Kg							
SampType: LCS	Run ID: ICP-MS3_140527A	Analysis Date: 5/27/2014 5:24:00 PM	Prep Date: 5/23/2014							
Analyte	Result	RL	SPK value	Ref Val	%REC	LowLimit	HighLimit	%RPD	RPDLimit	Qual

Arsenic	46.7	1.00	50.00	0	93.4	80	120			
Cadmium	47.6	0.300	50.00	0	95.2	80	120			
Chromium	47.2	2.00	50.00	0	94.4	80	120			
Copper	46.6	2.00	50.00	0	93.2	80	120			
Lead	48.7	0.300	50.00	0	97.4	80	120			
Nickel	47.8	2.00	50.00	0	95.6	80	120			
Selenium	47.5	0.500	50.00	0	95.0	80	120			
Silver	49.1	0.200	50.00	0	98.2	80	120			
Zinc	47.6	2.50	50.00	0	95.2	80	120			

Sample ID LCSD-63755	Batch ID: 63755	TestNo: SW6020A	Units: mg/Kg							
SampType: LCSD	Run ID: ICP-MS3_140527A	Analysis Date: 5/27/2014 5:30:00 PM	Prep Date: 5/23/2014							
Analyte	Result	RL	SPK value	Ref Val	%REC	LowLimit	HighLimit	%RPD	RPDLimit	Qual

Arsenic	49.0	1.00	50.00	0	98.0	80	120	4.81	20	
Cadmium	49.3	0.300	50.00	0	98.6	80	120	3.56	20	
Chromium	50.2	2.00	50.00	0	100	80	120	6.06	20	
Copper	48.6	2.00	50.00	0	97.2	80	120	4.20	20	
Lead	51.2	0.300	50.00	0	102	80	120	5.01	20	
Nickel	49.6	2.00	50.00	0	99.1	80	120	3.60	20	
Selenium	48.9	0.500	50.00	0	97.8	80	120	2.85	20	
Silver	51.1	0.200	50.00	0	102	80	120	3.94	20	
Zinc	49.7	2.50	50.00	0	99.4	80	120	4.32	20	

Qualifiers:	<p>B Analyte detected in the associated Method Blank</p> <p>J Analyte detected between MDL and RL</p> <p>ND Not Detected at the Method Detection Limit</p> <p>RL Reporting Limit</p> <p>J Analyte detected between SDL and RL</p>	<p>DF Dilution Factor</p> <p>MDL Method Detection Limit</p> <p>R RPD outside accepted control limits</p> <p>S Spike Recovery outside control limits</p> <p>N Parameter not NELAC certified</p>
--------------------	-----------------------------------------------------------------------------------------------------------------------------------------------------------------------------------------------------------------------------------	------------------------------------------------------------------------------------------------------------------------------------------------------------------------------------------------

CLIENT: Halff Associates, Inc
Work Order: 1405176
Project: Winnwood Ponds - Addison

ANALYTICAL QC SUMMARY REPORT

RunID: ICP-MS3_140527A

Sample ID 1405109-08A SD	Batch ID: 63755	TestNo: SW6020A	Units: mg/Kg-dry
SampType: SD	Run ID: ICP-MS3_140527A	Analysis Date: 5/27/2014 5:48:00 PM	Prep Date: 5/23/2014

Analyte	Result	RL	SPK value	Ref Val	%REC	LowLimit	HighLimit	%RPD	RPDLimit	Qual
Cadmium	<0.566	1.70	0	0.2076				0	10	
Copper	434	11.3	0	427.3				1.58	10	
Lead	10.0	1.70	0	9.899				1.34	10	
Nickel	3.19	11.3	0	3.188				0.177	10	
Selenium	1.88	2.83	0	1.403				28.9	10	R
Silver	<0.566	1.13	0	0				0	10	
Zinc	22.8	14.2	0	20.84				8.97	10	

Sample ID 1405109-08A PDS	Batch ID: 63755	TestNo: SW6020A	Units: mg/Kg-dry
SampType: PDS	Run ID: ICP-MS3_140527A	Analysis Date: 5/27/2014 6:48:00 PM	Prep Date: 5/23/2014

Analyte	Result	RL	SPK value	Ref Val	%REC	LowLimit	HighLimit	%RPD	RPDLimit	Qual
Cadmium	60.4	0.340	56.63	0.2076	106	80	120			
Copper	547	2.27	56.63	427.3	212	80	120			S
Lead	71.8	0.340	56.63	9.899	109	80	120			
Nickel	65.5	2.27	56.63	3.188	110	80	120			
Selenium	62.1	0.566	56.63	1.403	107	80	120			
Silver	63.1	0.227	56.63	0	111	80	120			
Zinc	84.4	2.83	56.63	20.84	112	80	120			

Sample ID 1405109-08A MS	Batch ID: 63755	TestNo: SW6020A	Units: mg/Kg-dry
SampType: MS	Run ID: ICP-MS3_140527A	Analysis Date: 5/27/2014 6:54:00 PM	Prep Date: 5/23/2014

Analyte	Result	RL	SPK value	Ref Val	%REC	LowLimit	HighLimit	%RPD	RPDLimit	Qual
Arsenic	803	1.13	56.63	818.0	-27.0	80	120			S
Cadmium	55.6	0.340	56.63	0.2076	97.9	80	120			
Chromium	738	2.27	56.63	648.1	158	80	120			S
Copper	377	2.27	56.63	427.3	-89.5	80	120			S
Lead	65.6	0.340	56.63	9.899	98.4	80	120			
Nickel	58.5	2.27	56.63	3.188	97.7	80	120			
Selenium	57.3	0.566	56.63	1.403	98.6	80	120			
Silver	55.8	0.227	56.63	0	98.5	80	120			
Zinc	73.7	2.83	56.63	20.84	93.4	80	120			

Sample ID 1405109-08A MSD	Batch ID: 63755	TestNo: SW6020A	Units: mg/Kg-dry
SampType: MSD	Run ID: ICP-MS3_140527A	Analysis Date: 5/27/2014 7:00:00 PM	Prep Date: 5/23/2014

Analyte	Result	RL	SPK value	Ref Val	%REC	LowLimit	HighLimit	%RPD	RPDLimit	Qual
Arsenic	721	1.13	56.63	818.0	-171	80	120	10.7	20	S
Cadmium	55.6	0.340	56.63	0.2076	97.8	80	120	0.050	20	
Chromium	608	2.27	56.63	648.1	-71.5	80	120	19.3	20	S

Qualifiers: B Analyte detected in the associated Method Blank DF Dilution Factor
J Analyte detected between MDL and RL MDL Method Detection Limit
ND Not Detected at the Method Detection Limit R RPD outside accepted control limits
RL Reporting Limit S Spike Recovery outside control limits
J Analyte detected between SDL and RL N Parameter not NELAC certified

CLIENT: Halff Associates, Inc
Work Order: 1405176
Project: Winnwood Ponds - Addison

ANALYTICAL QC SUMMARY REPORT

RunID: ICP-MS3_140527A

Sample ID: 1405109-08A MSD	Batch ID: 63755	TestNo: SW6020A	Units: mg/Kg-dry
SampType: MSD	Run ID: ICP-MS3_140527A	Analysis Date: 5/27/2014 7:00:00 PM	Prep Date: 5/23/2014

Analyte	Result	RL	SPK value	Ref Val	%REC	LowLimit	HighLimit	%RPD	RPDLimit	Qual
Copper	406	2.27	56.63	427.3	-38.0	80	120	7.46	20	S
Lead	64.7	0.340	56.63	9.899	96.8	80	120	1.39	20	
Nickel	57.3	2.27	56.63	3.188	95.5	80	120	2.15	20	
Selenium	56.7	0.566	56.63	1.403	97.7	80	120	0.944	20	
Silver	54.8	0.227	56.63	0	96.8	80	120	1.74	20	
Zinc	73.4	2.83	56.63	20.84	92.8	80	120	0.423	20	

Qualifiers: B Analyte detected in the associated Method Blank
 J Analyte detected between MDL and RL
 ND Not Detected at the Method Detection Limit
 RL Reporting Limit
 J Analyte detected between SDL and RL

DF Dilution Factor
 MDL Method Detection Limit
 R RPD outside accepted control limits
 S Spike Recovery outside control limits
 N Parameter not NELAC certified

CLIENT: Halff Associates, Inc
Work Order: 1405176
Project: Winnwood Ponds - Addison

ANALYTICAL QC SUMMARY REPORT

RunID: ICP-MS3_140527A

Sample ID: ILCVL-140527	Batch ID: R73359	TestNo: SW6020A	Units: mg/L
SampType: LCVL	Run ID: ICP-MS3_140527A	Analysis Date: 5/27/2014 1:45:00 PM	Prep Date:

Analyte	Result	RL	SPK value	Ref Val	%REC	LowLimit	HighLimit	%RPD	RPDLimit	Qual
Arsenic	0.00490	0.00500	0.00500	0	98.0	70	130			
Cadmium	0.000880	0.00100	0.00100	0	88.0	70	130			
Chromium	0.00496	0.00500	0.00500	0	99.3	70	130			
Copper	0.00488	0.0100	0.00500	0	97.5	70	130			
Lead	0.00101	0.00100	0.00100	0	101	70	130			
Nickel	0.00494	0.0100	0.00500	0	98.8	70	130			
Selenium	0.00550	0.00500	0.00500	0	110	70	130			
Silver	0.00180	0.00200	0.00200	0	89.9	70	130			
Zinc	0.00474	0.00500	0.00500	0	94.9	70	130			

Sample ID: LCVL2-140527	Batch ID: R73359	TestNo: SW6020A	Units: mg/L
SampType: LCVL	Run ID: ICP-MS3_140527A	Analysis Date: 5/27/2014 5:05:00 PM	Prep Date:

Analyte	Result	RL	SPK value	Ref Val	%REC	LowLimit	HighLimit	%RPD	RPDLimit	Qual
Arsenic	0.00477	0.00500	0.00500	0	95.4	70	130			
Cadmium	0.00109	0.00100	0.00100	0	109	70	130			
Chromium	0.00504	0.00500	0.00500	0	101	70	130			
Copper	0.00472	0.0100	0.00500	0	94.3	70	130			
Lead	0.00107	0.00100	0.00100	0	107	70	130			
Nickel	0.00480	0.0100	0.00500	0	95.9	70	130			
Selenium	0.00507	0.00500	0.00500	0	101	70	130			
Silver	0.00188	0.00200	0.00200	0	94.2	70	130			
Zinc	0.00485	0.00500	0.00500	0	97.1	70	130			

Sample ID: LCVL3-140527	Batch ID: R73359	TestNo: SW6020A	Units: mg/L
SampType: LCVL	Run ID: ICP-MS3_140527A	Analysis Date: 5/27/2014 7:42:00 PM	Prep Date:

Analyte	Result	RL	SPK value	Ref Val	%REC	LowLimit	HighLimit	%RPD	RPDLimit	Qual
Arsenic	0.00512	0.00500	0.00500	0	102	70	130			
Cadmium	0.000973	0.00100	0.00100	0	97.3	70	130			
Chromium	0.00497	0.00500	0.00500	0	99.5	70	130			
Copper	0.00464	0.0100	0.00500	0	92.8	70	130			
Lead	0.00105	0.00100	0.00100	0	104	70	130			
Nickel	0.00487	0.0100	0.00500	0	97.3	70	130			
Selenium	0.00544	0.00500	0.00500	0	109	70	130			
Silver	0.00179	0.00200	0.00200	0	89.5	70	130			
Zinc	0.00485	0.00500	0.00500	0	97.1	70	130			

Qualifiers: B Analyte detected in the associated Method Blank DF Dilution Factor
J Analyte detected between MDL and RL MDL Method Detection Limit
ND Not Detected at the Method Detection Limit R RPD outside accepted control limits
RL Reporting Limit S Spike Recovery outside control limits
J Analyte detected between SDL and RL N Parameter not NELAC certified

CLIENT: Halff Associates, Inc
Work Order: 1405176
Project: Winnwood Ponds - Addison

ANALYTICAL QC SUMMARY REPORT

RunID: ICP-MS3_140527A

Sample ID LCVL4-140527	Batch ID: R73359	TestNo: SW6020A	Units: mg/L
SampType: LCVL	Run ID: ICP-MS3_140527A	Analysis Date: 5/27/2014 9:24:00 PM	Prep Date:

Analyte	Result	RL	SPK value	Ref Val	%REC	LowLimit	HighLimit	%RPD	RPDLimit	Qual
Arsenic	0.00484	0.00500	0.00500	0	96.7	70	130			
Cadmium	0.000971	0.00100	0.00100	0	97.1	70	130			
Chromium	0.00475	0.00500	0.00500	0	95.0	70	130			
Copper	0.00469	0.0100	0.00500	0	93.7	70	130			
Lead	0.00101	0.00100	0.00100	0	101	70	130			
Nickel	0.00494	0.0100	0.00500	0	98.7	70	130			
Selenium	0.00515	0.00500	0.00500	0	103	70	130			
Silver	0.00177	0.00200	0.00200	0	88.3	70	130			
Zinc	0.00444	0.00500	0.00500	0	88.7	70	130			

Sample ID ICV1-140527	Batch ID: R73359	TestNo: SW6020A	Units: mg/L
SampType: ICV	Run ID: ICP-MS3_140527A	Analysis Date: 5/27/2014 1:33:00 PM	Prep Date:

Analyte	Result	RL	SPK value	Ref Val	%REC	LowLimit	HighLimit	%RPD	RPDLimit	Qual
Arsenic	0.0980	0.00500	0.100	0	98.0	90	110			
Cadmium	0.0971	0.00100	0.100	0	97.1	90	110			
Chromium	0.100	0.00500	0.100	0	101	90	110			
Copper	0.0980	0.0100	0.100	0	98.0	90	110			
Lead	0.0985	0.00100	0.100	0	98.5	90	110			
Nickel	0.101	0.0100	0.100	0	101	90	110			
Selenium	0.0980	0.00500	0.100	0	98.0	90	110			
Silver	0.0944	0.00200	0.100	0	94.4	90	110			
Zinc	0.101	0.00500	0.100	0	101	90	110			

Sample ID CCV2-140527	Batch ID: R73359	TestNo: SW6020A	Units: mg/L
SampType: CCV	Run ID: ICP-MS3_140527A	Analysis Date: 5/27/2014 4:53:00 PM	Prep Date:

Analyte	Result	RL	SPK value	Ref Val	%REC	LowLimit	HighLimit	%RPD	RPDLimit	Qual
Arsenic	0.196	0.00500	0.200	0	98.1	90	110			
Cadmium	0.198	0.00100	0.200	0	99.1	90	110			
Chromium	0.199	0.00500	0.200	0	99.6	90	110			
Copper	0.192	0.0100	0.200	0	96.0	90	110			
Lead	0.201	0.00100	0.200	0	100	90	110			
Nickel	0.192	0.0100	0.200	0	96.1	90	110			
Selenium	0.196	0.00500	0.200	0	98.2	90	110			
Silver	0.198	0.00200	0.200	0	99.2	90	110			
Zinc	0.205	0.00500	0.200	0	102	90	110			

Qualifiers: B Analyte detected in the associated Method Blank DF Dilution Factor
J Analyte detected between MDL and RL MDL Method Detection Limit
ND Not Detected at the Method Detection Limit R RPD outside accepted control limits
RL Reporting Limit S Spike Recovery outside control limits
J Analyte detected between SDL and RL N Parameter not NELAC certified

CLIENT: Halff Associates, Inc
Work Order: 1405176
Project: Winnwood Ponds - Addison

ANALYTICAL QC SUMMARY REPORT

RunID: ICP-MS3_140527A

Sample ID CCV3-140527	Batch ID: R73359	TestNo: SW6020A	Units: mg/L
SampType: CCV	Run ID: ICP-MS3_140527A	Analysis Date: 5/27/2014 7:06:00 PM	Prep Date:

Analyte	Result	RL	SPK value	Ref Val	%REC	LowLimit	HighLimit	%RPD	RPDLimit	Qual
Arsenic	0.204	0.00500	0.200	0	102	90	110			
Cadmium	0.197	0.00100	0.200	0	98.6	90	110			
Chromium	0.199	0.00500	0.200	0	99.6	90	110			
Copper	0.194	0.0100	0.200	0	97.2	90	110			
Lead	0.200	0.00100	0.200	0	100	90	110			
Nickel	0.196	0.0100	0.200	0	97.9	90	110			
Selenium	0.205	0.00500	0.200	0	103	90	110			
Silver	0.198	0.00200	0.200	0	98.8	90	110			
Zinc	0.206	0.00500	0.200	0	103	90	110			

Sample ID CCV4-140527	Batch ID: R73359	TestNo: SW6020A	Units: mg/L
SampType: CCV	Run ID: ICP-MS3_140527A	Analysis Date: 5/27/2014 8:48:00 PM	Prep Date:

Analyte	Result	RL	SPK value	Ref Val	%REC	LowLimit	HighLimit	%RPD	RPDLimit	Qual
Arsenic	0.202	0.00500	0.200	0	101	90	110			
Cadmium	0.196	0.00100	0.200	0	98.2	90	110			
Chromium	0.197	0.00500	0.200	0	98.6	90	110			
Copper	0.199	0.0100	0.200	0	99.7	90	110			
Lead	0.199	0.00100	0.200	0	99.4	90	110			
Nickel	0.203	0.0100	0.200	0	102	90	110			
Selenium	0.206	0.00500	0.200	0	103	90	110			
Silver	0.200	0.00200	0.200	0	100	90	110			
Zinc	0.204	0.00500	0.200	0	102	90	110			

Qualifiers:	<p>B Analyte detected in the associated Method Blank</p> <p>J Analyte detected between MDL and RL</p> <p>ND Not Detected at the Method Detection Limit</p> <p>RL Reporting Limit</p> <p>J Analyte detected between SDL and RL</p>	<p>DF Dilution Factor</p> <p>MDL Method Detection Limit</p> <p>R RPD outside accepted control limits</p> <p>S Spike Recovery outside control limits</p> <p>N Parameter not NELAC certified</p>
--------------------	----------------------------------------------------------------------------------------------------------------------------------------------------------------------------------------------------------------------------------------------------------------------	-----------------------------------------------------------------------------------------------------------------------------------------------------------------------------------------------------------------------------------

CLIENT: Halff Associates, Inc
Work Order: 1405176
Project: Winnwood Ponds - Addison

ANALYTICAL QC SUMMARY REPORT

RunID: ICP-MS4_140523B

Sample ID	DCS-63730-1	Batch ID:	63730	TestNo:	SW6020A	Units:	mg/Kg			
SampType:	DCS	Run ID:	ICP-MS4_140523B	Analysis Date:	5/23/2014 12:42:00 PM	Prep Date:	5/22/2014			
Analyte	Result	RL	SPK value	Ref Val	%REC	LowLimit	HighLimit	%RPD	RPDLimit	Qual
Arsenic	0.144	1.00	0.1500	0	95.7	80	120	0	0	
Chromium	0.149	2.00	0.1500	0	99.3	80	120	0	0	

Qualifiers: B Analyte detected in the associated Method Blank J Analyte detected between MDL and RL ND Not Detected at the Method Detection Limit RL Reporting Limit J Analyte detected between SDL and RL	DF Dilution Factor MDL Method Detection Limit R RPD outside accepted control limits S Spike Recovery outside control limits N Parameter not NELAC certified
----------------------------------------------------------------------------------------------------------------------------------------------------------------------------------------------------------------------------------	-------------------------------------------------------------------------------------------------------------------------------------------------------------------------

CLIENT: Halff Associates, Inc
Work Order: 1405176
Project: Winnwood Ponds - Addison

ANALYTICAL QC SUMMARY REPORT

RunID: ICP-MS4_140528A

The QC data in batch 63755 applies to the following samples: 1405176-01A, 1405176-02A, 1405176-03A

Sample ID 1405109-08A SD	Batch ID: 63755	TestNo: SW6020A	Units: mg/Kg-dry							
SampType: SD	Run ID: ICP-MS4_140528A	Analysis Date: 5/28/2014 1:11:00 PM	Prep Date: 5/23/2014							
Analyte	Result	RL	SPK value	Ref Val	%REC	LowLimit	HighLimit	%RPD	RPDLimit	Qual
Arsenic	768	28.3	0	783.2				1.95	10	
Chromium	642	56.6	0	690.1				7.21	10	

Sample ID 1405109-08A PDS	Batch ID: 63755	TestNo: SW6020A	Units: mg/Kg-dry							
SampType: PDS	Run ID: ICP-MS4_140528A	Analysis Date: 5/28/2014 1:13:00 PM	Prep Date: 5/23/2014							
Analyte	Result	RL	SPK value	Ref Val	%REC	LowLimit	HighLimit	%RPD	RPDLimit	Qual
Arsenic	1040	5.66	283.1	783.2	91.0	80	120			
Chromium	945	11.3	283.1	690.1	90.2	80	120			

Qualifiers:	B Analyte detected in the associated Method Blank	DF Dilution Factor
	J Analyte detected between MDL and RL	MDL Method Detection Limit
	ND Not Detected at the Method Detection Limit	R RPD outside accepted control limits
	RL Reporting Limit	S Spike Recovery outside control limits
	J Analyte detected between SDL and RL	N Parameter not NELAC certified

CLIENT: Halff Associates, Inc
Work Order: 1405176
Project: Winnwood Ponds - Addison

ANALYTICAL QC SUMMARY REPORT

RunID: ICP-MS4_140528A

Sample ID ICV-140528	Batch ID: R73383	TestNo: SW6020A	Units: mg/L							
SampType: ICV	Run ID: ICP-MS4_140528A	Analysis Date: 5/28/2014 10:22:00 AM	Prep Date:							
Analyte	Result	RL	SPK value	Ref Val	%REC	LowLimit	HighLimit	%RPD	RPDLimit	Qual
Arsenic	0.0928	0.00500	0.100	0	92.8	90	110			
Chromium	0.0987	0.00500	0.100	0	98.7	90	110			

Sample ID LCVL-140528	Batch ID: R73383	TestNo: SW6020A	Units: mg/L							
SampType: LCVL	Run ID: ICP-MS4_140528A	Analysis Date: 5/28/2014 10:26:00 AM	Prep Date:							
Analyte	Result	RL	SPK value	Ref Val	%REC	LowLimit	HighLimit	%RPD	RPDLimit	Qual
Arsenic	0.00460	0.00500	0.00500	0	91.9	70	130			
Chromium	0.00505	0.00500	0.00500	0	101	70	130			

Sample ID CCV4-140528	Batch ID: R73383	TestNo: SW6020A	Units: mg/L							
SampType: CCV	Run ID: ICP-MS4_140528A	Analysis Date: 5/28/2014 12:47:00 PM	Prep Date:							
Analyte	Result	RL	SPK value	Ref Val	%REC	LowLimit	HighLimit	%RPD	RPDLimit	Qual
Arsenic	0.186	0.00500	0.200	0	93.0	90	110			
Chromium	0.219	0.00500	0.200	0	110	90	110			

Sample ID LCVL4-140528	Batch ID: R73383	TestNo: SW6020A	Units: mg/L							
SampType: LCVL	Run ID: ICP-MS4_140528A	Analysis Date: 5/28/2014 12:51:00 PM	Prep Date:							
Analyte	Result	RL	SPK value	Ref Val	%REC	LowLimit	HighLimit	%RPD	RPDLimit	Qual
Arsenic	0.00458	0.00500	0.00500	0	91.6	70	130			
Chromium	0.00508	0.00500	0.00500	0	102	70	130			

Sample ID CCV5-140528	Batch ID: R73383	TestNo: SW6020A	Units: mg/L							
SampType: CCV	Run ID: ICP-MS4_140528A	Analysis Date: 5/28/2014 1:15:00 PM	Prep Date:							
Analyte	Result	RL	SPK value	Ref Val	%REC	LowLimit	HighLimit	%RPD	RPDLimit	Qual
Arsenic	0.191	0.00500	0.200	0	95.3	90	110			
Chromium	0.205	0.00500	0.200	0	102	90	110			

Sample ID LCVL5-140528	Batch ID: R73383	TestNo: SW6020A	Units: mg/L							
SampType: LCVL	Run ID: ICP-MS4_140528A	Analysis Date: 5/28/2014 1:18:00 PM	Prep Date:							
Analyte	Result	RL	SPK value	Ref Val	%REC	LowLimit	HighLimit	%RPD	RPDLimit	Qual
Arsenic	0.00462	0.00500	0.00500	0	92.4	70	130			
Chromium	0.00510	0.00500	0.00500	0	102	70	130			

Qualifiers: B Analyte detected in the associated Method Blank DF Dilution Factor
J Analyte detected between MDL and RL MDL Method Detection Limit
ND Not Detected at the Method Detection Limit R RPD outside accepted control limits
RL Reporting Limit S Spike Recovery outside control limits
J Analyte detected between SDL and RL N Parameter not NELAC certified

CLIENT: Halff Associates, Inc
Work Order: 1405176
Project: Winnwood Ponds - Addison

ANALYTICAL QC SUMMARY REPORT

RunID: GCMS10_140228A

Sample ID: DCS1-62013	Batch ID: 62013	TestNo: SW8270D	Units: mg/Kg
SampType: DCS	Run ID: GCMS10_140228A	Analysis Date: 2/28/2014 4:25:00 PM	Prep Date: 2/24/2014

Analyte	Result	RL	SPK value	Ref Val	%REC	LowLimit	HighLimit	%RPD	RPDLimit	Qual
4,4'-DDD	0.00675	0.00600	0.005000	0	135	10	400	0	0	
4,4'-DDE	0.00522	0.00600	0.005000	0	104	10	400	0	0	
4,4'-DDT	0.00740	0.00600	0.005000	0	148	10	400	0	0	
Aldrin	0.00405	0.00600	0.005000	0	81.0	10	400	0	0	
alpha-BHC	0.00450	0.00600	0.005000	0	90.0	10	400	0	0	
alpha-Chlordane	0.00545	0.00600	0.005000	0	109	10	400	0	0	
beta-BHC	0.00501	0.00600	0.005000	0	100	10	400	0	0	
delta-BHC	0.00363	0.00600	0.005000	0	72.6	10	400	0	0	
Dieldrin	0.00587	0.00600	0.005000	0	117	10	400	0	0	
Endosulfan I	0.00549	0.00600	0.005000	0	110	10	400	0	0	
Endosulfan II	0.00664	0.00600	0.005000	0	133	10	400	0	0	
Endosulfan sulfate	0.00710	0.00600	0.005000	0	142	10	400	0	0	
Endrin	0.00808	0.00600	0.005000	0	162	10	400	0	0	
Endrin aldehyde	0.00826	0.00600	0.005000	0	165	10	400	0	0	
Endrin ketone	0.00796	0.00600	0.005000	0	159	10	400	0	0	
gamma-BHC	0.00449	0.00600	0.005000	0	89.8	10	400	0	0	
gamma-Chlordane	0.00527	0.00600	0.005000	0	105	10	400	0	0	
Heptachlor	0.00637	0.00600	0.005000	0	127	10	400	0	0	
Heptachlor epoxide	0.00656	0.00600	0.005000	0	131	10	400	0	0	
Methoxychlor	0.00729	0.00600	0.005000	0	146	10	400	0	0	

Sample ID: DCS2-62013	Batch ID: 62013	TestNo: SW8270D	Units: mg/Kg
SampType: DCS	Run ID: GCMS10_140228A	Analysis Date: 2/28/2014 5:26:00 PM	Prep Date: 2/24/2014

Analyte	Result	RL	SPK value	Ref Val	%REC	LowLimit	HighLimit	%RPD	RPDLimit	Qual
Chlordane	0.0206	0.0300	0.02000	0	103	10	400	0	0	
Toxaphene	0.218	0.250	0.2000	0	109	10	400	0	0	

Qualifiers:

B	Analyte detected in the associated Method Blank	DF	Dilution Factor
J	Analyte detected between MDL and RL	MDL	Method Detection Limit
ND	Not Detected at the Method Detection Limit	R	RPD outside accepted control limits
RL	Reporting Limit	S	Spike Recovery outside control limits
J	Analyte detected between SDL and RL	N	Parameter not NELAC certified

CLIENT: Halff Associates, Inc
Work Order: 1405176
Project: Winnwood Ponds - Addison

ANALYTICAL QC SUMMARY REPORT

RunID: GCMS10_140527A

The QC data in batch 63748 applies to the following samples: 1405176-01B, 1405176-02B, 1405176-03B

Sample ID: LCS-63748	Batch ID: 63748	TestNo: SW8270D	Units: mg/Kg
SampType: LCS	Run ID: GCMS10_140527A	Analysis Date: 5/27/2014 4:13:00 PM	Prep Date: 5/22/2014

Analyte	Result	RL	SPK value	Ref Val	%REC	LowLimit	HighLimit	%RPD	RPDLimit	Qual
4,4'-DDD	0.0770	0.00600	0.1000	0	77.0	50	139			
4,4'-DDE	0.0812	0.00600	0.1000	0	81.2	68	126			
4,4'-DDT	0.0924	0.00600	0.1000	0	92.4	46	135			
Aldrin	0.0697	0.00600	0.1000	0	69.7	47	120			
alpha-BHC	0.0798	0.00600	0.1000	0	79.8	62	125			
alpha-Chlordane	0.0731	0.00600	0.1000	0	73.1	63	121			
beta-BHC	0.0763	0.00600	0.1000	0	76.3	62	127			
delta-BHC	0.0708	0.00600	0.1000	0	70.8	57	130			
Dieldrin	0.0703	0.00600	0.1000	0	70.3	67	125			
Endosulfan I	0.0723	0.00600	0.1000	0	72.3	41	147			
Endosulfan II	0.0747	0.00600	0.1000	0	74.7	37	141			
Endosulfan sulfate	0.0845	0.00600	0.1000	0	84.5	62	135			
Endrin	0.102	0.00600	0.1000	0	102	61	133			
Endrin aldehyde	0.0701	0.00600	0.1000	0	70.1	37	147			
Endrin ketone	0.0766	0.00600	0.1000	0	76.6	65	135			
gamma-BHC	0.0765	0.00600	0.1000	0	76.5	59	123			
gamma-Chlordane	0.0720	0.00600	0.1000	0	72.0	48	124			
Heptachlor	0.0804	0.00600	0.1000	0	80.4	51	140			
Heptachlor epoxide	0.0714	0.00600	0.1000	0	71.4	66	130			
Methoxychlor	0.0991	0.00600	0.1000	0	99.1	57	143			
Surr: 2-Fluorobiphenyl	1.01		1.000		101	43	125			
Surr: 4-Terphenyl-d14	1.15		1.000		115	32	125			

Sample ID: 1405163-04AMS	Batch ID: 63748	TestNo: SW8270D	Units: mg/Kg-dry
SampType: MS	Run ID: GCMS10_140527A	Analysis Date: 5/27/2014 4:43:00 PM	Prep Date: 5/22/2014

Analyte	Result	RL	SPK value	Ref Val	%REC	LowLimit	HighLimit	%RPD	RPDLimit	Qual
4,4'-DDD	0.114	0.00707	0.1179	0.01355	85.3	50	139			
4,4'-DDE	0.425	0.00707	0.1179	0.3510	63.0	68	126			S
4,4'-DDT	0.149	0.00707	0.1179	0.01342	115	46	135			
Aldrin	0.0791	0.00707	0.1179	0	67.1	47	120			
alpha-BHC	0.0890	0.00707	0.1179	0	75.5	62	125			
alpha-Chlordane	0.0899	0.00707	0.1179	0	76.3	63	121			
beta-BHC	0.0888	0.00707	0.1179	0	75.4	62	127			
delta-BHC	0.0815	0.00707	0.1179	0	69.2	57	130			
Dieldrin	0.105	0.00707	0.1179	0.01607	75.5	67	125			
Endosulfan I	0.106	0.00707	0.1179	0.01131	80.5	41	147			
Endosulfan II	0.0666	0.00707	0.1179	0.04527	18.1	37	141			S
Endosulfan sulfate	0.108	0.00707	0.1179	0	91.9	62	135			
Endrin	0.156	0.00707	0.1179	0.01715	118	61	133			

Qualifiers: B Analyte detected in the associated Method Blank DF Dilution Factor
J Analyte detected between MDL and RL MDL Method Detection Limit
ND Not Detected at the Method Detection Limit R RPD outside accepted control limits
RL Reporting Limit S Spike Recovery outside control limits
J Analyte detected between SDL and RL N Parameter not NELAC certified

CLIENT: Half Associates, Inc
 Work Order: 1405176
 Project: Winnwood Ponds - Addison

ANALYTICAL QC SUMMARY REPORT

RunID: GCMS10_140527A

Sample ID: 1405163-04AMS	Batch ID: 63748	TestNo: SW8270D	Units: mg/Kg-dry
SampType: MS	Run ID: GCMS10_140527A	Analysis Date: 5/27/2014 4:43:00 PM	Prep Date: 5/22/2014

Analyte	Result	RL	SPK value	Ref Val	%REC	LowLimit	HighLimit	%RPD	RPDLimit	Qual
Endrin aldehyde	0.104	0.00707	0.1179	0.01208	78.2	37	147			
Endrin ketone	0.107	0.00707	0.1179	0	90.7	65	135			
gamma-BHC	0.0864	0.00707	0.1179	0	73.3	59	123			
gamma-Chlordane	0.0888	0.00707	0.1179	0	75.4	48	124			
Heptachlor	0.0934	0.00707	0.1179	0	79.2	51	140			
Heptachlor epoxide	0.0943	0.00707	0.1179	0	80.0	66	130			
Methoxychlor	0.129	0.00707	0.1179	0	110	57	143			
Surr: 2-Fluorobiphenyl	1.08		1.179		91.5	43	125			
Surr: 4-Terphenyl-d14	1.28		1.179		109	32	125			

Sample ID: 1405163-04AMSD	Batch ID: 63748	TestNo: SW8270D	Units: mg/Kg-dry
SampType: MSD	Run ID: GCMS10_140527A	Analysis Date: 5/27/2014 5:14:00 PM	Prep Date: 5/22/2014

Analyte	Result	RL	SPK value	Ref Val	%REC	LowLimit	HighLimit	%RPD	RPDLimit	Qual
4,4'-DDD	0.115	0.00702	0.1170	0.01355	86.6	50	139	0.721	30	
4,4'-DDE	0.488	0.00702	0.1170	0.3510	117	68	126	13.7	30	
4,4'-DDT	0.150	0.00702	0.1170	0.01342	117	46	135	0.782	30	
Aldrin	0.0777	0.00702	0.1170	0	66.4	47	120	1.84	30	
alpha-BHC	0.0874	0.00702	0.1170	0	74.7	62	125	1.83	30	
alpha-Chlordane	0.0872	0.00702	0.1170	0	74.6	63	121	3.06	30	
beta-BHC	0.0852	0.00702	0.1170	0	72.8	62	127	4.19	30	
delta-BHC	0.0802	0.00702	0.1170	0	68.6	57	130	1.61	30	
Dieldrin	0.108	0.00702	0.1170	0.01607	78.5	67	125	2.75	30	
Endosulfan I	0.106	0.00702	0.1170	0.01131	81.1	41	147	0.080	30	
Endosulfan II	0.0823	0.00702	0.1170	0.04527	31.6	37	141	21.1	30	S
Endosulfan sulfate	0.108	0.00702	0.1170	0	92.1	62	135	0.484	30	
Endrin	0.159	0.00702	0.1170	0.01715	121	61	133	1.99	30	
Endrin aldehyde	0.107	0.00702	0.1170	0.01208	81.3	37	147	2.83	30	
Endrin ketone	0.109	0.00702	0.1170	0	93.4	65	135	2.18	30	
gamma-BHC	0.0840	0.00702	0.1170	0	71.8	59	123	2.86	30	
gamma-Chlordane	0.0878	0.00702	0.1170	0	75.1	48	124	1.11	30	
Heptachlor	0.0928	0.00702	0.1170	0	79.4	51	140	0.602	30	
Heptachlor epoxide	0.0883	0.00702	0.1170	0	75.5	66	130	6.51	30	
Methoxychlor	0.128	0.00702	0.1170	0	110	57	143	0.712	30	
Surr: 2-Fluorobiphenyl	1.06		1.170		90.6	43	125	0		
Surr: 4-Terphenyl-d14	1.28		1.170		110	32	125	0		

Sample ID: 1405201-02AMS	Batch ID: 63748	TestNo: SW8270D	Units: mg/Kg-dry
SampType: MS	Run ID: GCMS10_140527A	Analysis Date: 5/27/2014 5:45:00 PM	Prep Date: 5/22/2014

Analyte	Result	RL	SPK value	Ref Val	%REC	LowLimit	HighLimit	%RPD	RPDLimit	Qual
---------	--------	----	-----------	---------	------	----------	-----------	------	----------	------

Qualifiers:

B	Analyte detected in the associated Method Blank	DF	Dilution Factor
J	Analyte detected between MDL and RL	MDL	Method Detection Limit
ND	Not Detected at the Method Detection Limit	R	RPD outside accepted control limits
RL	Reporting Limit	S	Spike Recovery outside control limits
J	Analyte detected between SDL and RL	N	Parameter not NELAC certified

CLIENT: Halff Associates, Inc
Work Order: 1405176
Project: Winnwood Ponds - Addison

ANALYTICAL QC SUMMARY REPORT

RunID: GCMS10_140527A

Sample ID: 1405201-02AMS	Batch ID: 63748	TestNo: SW8270D	Units: mg/Kg-dry
SampType: MS	Run ID: GCMS10_140527A	Analysis Date: 5/27/2014 5:45:00 PM	Prep Date: 5/22/2014

Analyte	Result	RL	SPK value	Ref Val	%REC	LowLimit	HighLimit	%RPD	RPDLimit	Qual
4,4'-DDD	0.140	0.00947	0.1579	0	88.7	50	139			
4,4'-DDE	0.133	0.00947	0.1579	0	84.1	68	126			
4,4'-DDT	0.197	0.00947	0.1579	0.01304	116	46	135			
Aldrin	0.109	0.00947	0.1579	0	69.0	47	120			
alpha-BHC	0.124	0.00947	0.1579	0	78.6	62	125			
alpha-Chlordane	0.123	0.00947	0.1579	0	77.7	63	121			
beta-BHC	0.122	0.00947	0.1579	0	77.1	62	127			
delta-BHC	0.117	0.00947	0.1579	0	74.4	57	130			
Dieldrin	0.124	0.00947	0.1579	0	78.4	67	125			
Endosulfan I	0.124	0.00947	0.1579	0	78.8	41	147			
Endosulfan II	0.133	0.00947	0.1579	0	84.4	37	141			
Endosulfan sulfate	0.148	0.00947	0.1579	0	94.0	62	135			
Endrin	0.201	0.00947	0.1579	0	127	61	133			
Endrin aldehyde	0.133	0.00947	0.1579	0	84.1	37	147			
Endrin ketone	0.149	0.00947	0.1579	0	94.5	65	135			
gamma-BHC	0.119	0.00947	0.1579	0	75.2	59	123			
gamma-Chlordane	0.123	0.00947	0.1579	0	77.8	48	124			
Heptachlor	0.134	0.00947	0.1579	0	84.6	51	140			
Heptachlor epoxide	0.127	0.00947	0.1579	0	80.7	66	130			
Methoxychlor	0.169	0.00947	0.1579	0	107	57	143			
Surr: 2-Fluorobiphenyl	1.47		1.579		93.2	43	125			
Surr: 4-Terphenyl-d14	1.73		1.579		109	32	125			

Sample ID: 1405201-02AMSD	Batch ID: 63748	TestNo: SW8270D	Units: mg/Kg-dry
SampType: MSD	Run ID: GCMS10_140527A	Analysis Date: 5/27/2014 6:16:00 PM	Prep Date: 5/22/2014

Analyte	Result	RL	SPK value	Ref Val	%REC	LowLimit	HighLimit	%RPD	RPDLimit	Qual
4,4'-DDD	0.147	0.00921	0.1535	0	96.1	50	139	5.19	30	
4,4'-DDE	0.130	0.00921	0.1535	0	84.5	68	126	2.34	30	
4,4'-DDT	0.158	0.00921	0.1535	0.01304	94.7	46	135	21.5	30	
Aldrin	0.106	0.00921	0.1535	0	68.9	47	120	2.96	30	
alpha-BHC	0.120	0.00921	0.1535	0	78.0	62	125	3.54	30	
alpha-Chlordane	0.120	0.00921	0.1535	0	78.2	63	121	2.17	30	
beta-BHC	0.118	0.00921	0.1535	0	76.9	62	127	3.09	30	
delta-BHC	0.114	0.00921	0.1535	0	74.1	57	130	3.26	30	
Dieldrin	0.121	0.00921	0.1535	0	78.5	67	125	2.58	30	
Endosulfan I	0.124	0.00921	0.1535	0	81.0	41	147	0.147	30	
Endosulfan II	0.138	0.00921	0.1535	0	89.6	37	141	3.11	30	
Endosulfan sulfate	0.147	0.00921	0.1535	0	96.1	62	135	0.665	30	
Endrin	0.204	0.00921	0.1535	0	133	61	133	1.48	30	
Endrin aldehyde	0.131	0.00921	0.1535	0	85.2	37	147	1.57	30	

Qualifiers: B Analyte detected in the associated Method Blank DF Dilution Factor
J Analyte detected between MDL and RL MDL Method Detection Limit
ND Not Detected at the Method Detection Limit R RPD outside accepted control limits
RL Reporting Limit S Spike Recovery outside control limits
J Analyte detected between SDL and RL N Parameter not NELAC certified

CLIENT: Halff Associates, Inc
Work Order: 1405176
Project: Winnwood Ponds - Addison

ANALYTICAL QC SUMMARY REPORT

RunID: GCMS10_140527A

Sample ID: 1405201-02AMSD	Batch ID: 63748	TestNo: SW8270D	Units: mg/Kg-dry
SampType: MSD	Run ID: GCMS10_140527A	Analysis Date: 5/27/2014 6:16:00 PM	Prep Date: 5/22/2014

Analyte	Result	RL	SPK value	Ref Val	%REC	LowLimit	HighLimit	%RPD	RPDLimit	Qual
Endrin ketone	0.146	0.00921	0.1535	0	95.2	65	135	2.07	30	
gamma-BHC	0.115	0.00921	0.1535	0	74.9	59	123	3.24	30	
gamma-Chlordane	0.121	0.00921	0.1535	0	79.0	48	124	1.23	30	
Heptachlor	0.131	0.00921	0.1535	0	85.3	51	140	1.95	30	
Heptachlor epoxide	0.126	0.00921	0.1535	0	81.8	66	130	1.51	30	
Methoxychlor	0.134	0.00921	0.1535	0	87.5	57	143	23.1	30	
Surr: 2-Fluorobiphenyl	1.38		1.535		89.8	43	125	0		
Surr: 4-Terphenyl-d14	1.67		1.535		109	32	125	0		

Sample ID: MB-63748	Batch ID: 63748	TestNo: SW8270D	Units: mg/Kg
SampType: MBLK	Run ID: GCMS10_140527A	Analysis Date: 5/27/2014 6:47:00 PM	Prep Date: 5/22/2014

Analyte	Result	RL	SPK value	Ref Val	%REC	LowLimit	HighLimit	%RPD	RPDLimit	Qual
4,4'-DDD	<0.00200	0.00600								
4,4'-DDE	<0.00200	0.00600								
4,4'-DDT	<0.00200	0.00600								
Aldrin	<0.00200	0.00600								
alpha-BHC	<0.00200	0.00600								
alpha-Chlordane	<0.00200	0.00600								
beta-BHC	<0.00200	0.00600								
Chlordane	<0.0100	0.0300								
delta-BHC	<0.00200	0.00600								
Dieldrin	<0.00200	0.00600								
Endosulfan I	<0.00200	0.00600								
Endosulfan II	<0.00200	0.00600								
Endosulfan sulfate	<0.00200	0.00600								
Endrin	<0.00200	0.00600								
Endrin aldehyde	<0.00200	0.00600								
Endrin ketone	<0.00200	0.00600								
gamma-BHC	<0.00200	0.00600								
gamma-Chlordane	<0.00200	0.00600								
Heptachlor	<0.00200	0.00600								
Heptachlor epoxide	<0.00200	0.00600								
Methoxychlor	<0.00200	0.00600								
Toxaphene	<0.0800	0.250								
Surr: 2-Fluorobiphenyl	0.979		1.000		97.9	43	125			
Surr: 4-Terphenyl-d14	1.18		1.000		118	32	125			

Qualifiers:

B	Analyte detected in the associated Method Blank	DF	Dilution Factor
J	Analyte detected between MDL and RL	MDL	Method Detection Limit
ND	Not Detected at the Method Detection Limit	R	RPD outside accepted control limits
RL	Reporting Limit	S	Spike Recovery outside control limits
J	Analyte detected between SDL and RL	N	Parameter not NELAC certified

CLIENT: Halff Associates, Inc
Work Order: 1405176
Project: Winnwood Ponds - Addison

ANALYTICAL QC SUMMARY REPORT

RunID: GCMS10_140527A

Sample ID: ICV-140527	Batch ID: R73351	TestNo: SW8270D	Units: mg/Kg
SampType: ICV	Run ID: GCMS10_140527A	Analysis Date: 5/27/2014 3:11:00 PM	Prep Date:

Analyte	Result	RL	SPK value	Ref Val	%REC	LowLimit	HighLimit	%RPD	RPDLimit	Qual
4,4'-DDD	0.191	0.00600	0.2000	0	95.4	80	120			
4,4'-DDE	0.194	0.00600	0.2000	0	97.2	80	120			
4,4'-DDT	0.239	0.00600	0.2000	0	120	80	120			
Aldrin	0.164	0.00600	0.2000	0	82.2	80	120			
alpha-BHC	0.191	0.00600	0.2000	0	95.4	80	120			
alpha-Chlordane	0.178	0.00600	0.2000	0	88.8	80	120			
beta-BHC	0.183	0.00600	0.2000	0	91.5	80	120			
delta-BHC	0.166	0.00600	0.2000	0	82.9	80	120			
Dieldrin	0.172	0.00600	0.2000	0	86.2	80	120			
Endosulfan I	0.178	0.00600	0.2000	0	88.8	80	120			
Endosulfan II	0.180	0.00600	0.2000	0	90.0	80	120			
Endosulfan sulfate	0.213	0.00600	0.2000	0	106	80	120			
Endrin	0.242	0.00600	0.2000	0	121	80	120			S
Endrin aldehyde	0.161	0.00600	0.2000	0	80.4	80	120			
Endrin ketone	0.188	0.00600	0.2000	0	94.0	80	120			
gamma-BHC	0.184	0.00600	0.2000	0	92.2	80	120			
gamma-Chlordane	0.173	0.00600	0.2000	0	86.7	80	120			
Heptachlor	0.189	0.00600	0.2000	0	94.5	80	120			
Heptachlor epoxide	0.182	0.00600	0.2000	0	91.2	80	120			
Methoxychlor	0.242	0.00600	0.2000	0	121	80	120			S
Surr: 2-Fluorobiphenyl	0.806		0.8000		101	80	120			
Surr: 4-Terphenyl-d14	0.861		0.8000		108	80	120			

Sample ID: ICV-140527 C/T	Batch ID: R73351	TestNo: SW8270D	Units: mg/Kg
SampType: ICV	Run ID: GCMS10_140527A	Analysis Date: 5/27/2014 3:42:00 PM	Prep Date:

Analyte	Result	RL	SPK value	Ref Val	%REC	LowLimit	HighLimit	%RPD	RPDLimit	Qual
Chlordane	0.823	0.0300	1.000	0	82.3	80	120			
Toxaphene	11.7	0.250	10.00	0	117	80	120			

Qualifiers:

B	Analyte detected in the associated Method Blank	DF	Dilution Factor
J	Analyte detected between MDL and RL	MDL	Method Detection Limit
ND	Not Detected at the Method Detection Limit	R	RPD outside accepted control limits
RL	Reporting Limit	S	Spike Recovery outside control limits
J	Analyte detected between SDL and RL	N	Parameter not NELAC certified

CLIENT: Halff Associates, Inc
Work Order: 1405176
Project: Winnwood Ponds - Addison

ANALYTICAL QC SUMMARY REPORT

RunID: GCMS8_140412A

Sample ID	DCS-62852	Batch ID:	62852	TestNo:	SW8270D	Units:	mg/Kg			
SampType:	DCS	Run ID:	GCMS8_140412A	Analysis Date:	4/12/2014 2:07:00 PM	Prep Date:	4/11/2014			
Analyte	Result	RL	SPK value	Ref Val	%REC	LowLimit	HighLimit	%RPD	RPDLimit	Qual
Aroclor 1016	0.0388	0.0500	0.05000	0	77.6	20	400	0	0	
Aroclor 1260	0.0445	0.0500	0.05000	0	89.1	20	400	0	0	

Qualifiers: B Analyte detected in the associated Method Blank J Analyte detected between MDL and RL ND Not Detected at the Method Detection Limit RL Reporting Limit J Analyte detected between SDL and RL	DF Dilution Factor MDL Method Detection Limit R RPD outside accepted control limits S Spike Recovery outside control limits N Parameter not NELAC certified
----------------------------------------------------------------------------------------------------------------------------------------------------------------------------------------------------------------------------------	-------------------------------------------------------------------------------------------------------------------------------------------------------------------------

CLIENT: Halff Associates, Inc
Work Order: 1405176
Project: Winnwood Ponds - Addison

ANALYTICAL QC SUMMARY REPORT

RunID: GCMS8_140522A

The QC data in batch 63727 applies to the following samples: 1405176-01B, 1405176-02B, 1405176-03B

Sample ID LCS-63727	Batch ID: 63727	TestNo: SW8270D	Units: mg/Kg
SampType: LCS	Run ID: GCMS8_140522A	Analysis Date: 5/22/2014 4:31:00 PM	Prep Date: 5/22/2014

Analyte	Result	RL	SPK value	Ref Val	%REC	LowLimit	HighLimit	%RPD	RPDLimit	Qual
Aroclor 1016	0.834	0.0500	1.000	0	83.4	41	138			
Aroclor 1260	0.841	0.0500	1.000	0	84.1	61	131			
Surr: 2-Fluorobiphenyl	1.01		1.000		101	43	125			
Surr: 4-Terphenyl-d14	1.17		1.000		117	32	125			

Sample ID MB-63727	Batch ID: 63727	TestNo: SW8270D	Units: mg/Kg
SampType: MBLK	Run ID: GCMS8_140522A	Analysis Date: 5/22/2014 5:02:00 PM	Prep Date: 5/22/2014

Analyte	Result	RL	SPK value	Ref Val	%REC	LowLimit	HighLimit	%RPD	RPDLimit	Qual
Aroclor 1016	<0.0250	0.0500								
Aroclor 1221	<0.0250	0.0500								
Aroclor 1232	<0.0250	0.0500								
Aroclor 1242	<0.0250	0.0500								
Aroclor 1248	<0.0250	0.0500								
Aroclor 1254	<0.0250	0.0500								
Aroclor 1260	<0.0250	0.0500								
Surr: 2-Fluorobiphenyl	1.10		1.000		110	43	125			
Surr: 4-Terphenyl-d14	1.23		1.000		123	32	125			

Sample ID 1405176-03BMS	Batch ID: 63727	TestNo: SW8270D	Units: mg/Kg-dry
SampType: MS	Run ID: GCMS8_140522A	Analysis Date: 5/22/2014 9:10:00 PM	Prep Date: 5/22/2014

Analyte	Result	RL	SPK value	Ref Val	%REC	LowLimit	HighLimit	%RPD	RPDLimit	Qual
Aroclor 1016	2.55	0.787	3.148	0	81.1	41	138			
Aroclor 1260	2.70	0.787	3.148	0	85.7	61	131			
Surr: 2-Fluorobiphenyl	3.18		3.148		101	43	125			
Surr: 4-Terphenyl-d14	3.26		3.148		104	32	125			

Sample ID 1405176-03BMSD	Batch ID: 63727	TestNo: SW8270D	Units: mg/Kg-dry
SampType: MSD	Run ID: GCMS8_140522A	Analysis Date: 5/22/2014 9:41:00 PM	Prep Date: 5/22/2014

Analyte	Result	RL	SPK value	Ref Val	%REC	LowLimit	HighLimit	%RPD	RPDLimit	Qual
Aroclor 1016	2.63	0.794	3.175	0	83.0	41	138	3.14	50	
Aroclor 1260	2.69	0.794	3.175	0	84.6	61	131	0.374	50	
Surr: 2-Fluorobiphenyl	3.20		3.175		101	43	125	0	0	
Surr: 4-Terphenyl-d14	3.18		3.175		100	32	125	0	0	

Qualifiers:

B Analyte detected in the associated Method Blank	DF Dilution Factor
J Analyte detected between MDL and RL	MDL Method Detection Limit
ND Not Detected at the Method Detection Limit	R RPD outside accepted control limits
RL Reporting Limit	S Spike Recovery outside control limits
J Analyte detected between SDL and RL	N Parameter not NELAC certified

CLIENT: Halff Associates, Inc
Work Order: 1405176
Project: Winnwood Ponds - Addison

ANALYTICAL QC SUMMARY REPORT

RunID: GCMS8_140522A

Sample ID ICV-140522	Batch ID: R73291	TestNo: SW8270D	Units: mg/Kg
SampType: ICV	Run ID: GCMS8_140522A	Analysis Date: 5/22/2014 4:00:00 PM	Prep Date:

Analyte	Result	RL	SPK value	Ref Val	%REC	LowLimit	HighLimit	%RPD	RPDLimit	Qual
Aroclor 1016	1.85	0.0500	2.000	0	92.6	80	120			
Aroclor 1260	1.71	0.0500	2.000	0	85.5	80	120			
Surr: 2-Fluorobiphenyl	1.94		2.000		97.1	80	120			
Surr: 4-Terphenyl-d14	1.76		2.000		88.1	80	120			

Qualifiers: B Analyte detected in the associated Method Blank DF Dilution Factor
 J Analyte detected between MDL and RL MDL Method Detection Limit
 ND Not Detected at the Method Detection Limit R RPD outside accepted control limits
 RL Reporting Limit S Spike Recovery outside control limits
 J Analyte detected between SDL and RL N Parameter not NELAC certified

CLIENT: Halff Associates, Inc
Work Order: 1405176
Project: Winnwood Ponds - Addison

ANALYTICAL QC SUMMARY REPORT

RunID: GCMS9_140428A

Sample ID: DCS1-63175	Batch ID: 63175	TestNo: SW8270D	Units: mg/Kg
SampType: DCS	Run ID: GCMS9_140428A	Analysis Date: 4/28/2014 12:47:00 PM	Prep Date: 4/25/2014

Analyte	Result	RL	SPK value	Ref Val	%REC	LowLimit	HighLimit	%RPD	RPDLimit	Qual
Acenaphthene	0.0160	0.0266	0.02000	0	80.0	10	400	0	0	
Acenaphthylene	0.0147	0.0266	0.02000	0	73.3	10	400	0	0	
Anthracene	0.0167	0.0266	0.02000	0	83.3	10	400	0	0	
Benzo[a]anthracene	0.0220	0.0266	0.02000	0	110	10	400	0	0	
Benzo[a]pyrene	0.0167	0.0266	0.02000	0	83.3	10	400	0	0	
Benzo[b]fluoranthene	0.0160	0.0266	0.02000	0	80.0	10	400	0	0	
Benzo[g,h,i]perylene	0.0167	0.0266	0.02000	0	83.3	10	400	0	0	
Benzo[k]fluoranthene	0.0167	0.0266	0.02000	0	83.3	10	400	0	0	
Chrysene	0.0173	0.0266	0.02000	0	86.7	10	400	0	0	
Dibenz[a,h]anthracene	0.0167	0.0266	0.02000	0	83.3	10	400	0	0	
Fluoranthene	0.0173	0.0266	0.02000	0	86.7	10	400	0	0	
Fluorene	0.0160	0.0266	0.02000	0	80.0	10	400	0	0	
Indeno[1,2,3-cd]pyrene	0.0167	0.0266	0.02000	0	83.3	10	400	0	0	
Naphthalene	0.0127	0.0266	0.02000	0	63.3	10	400	0	0	
Phenanthrene	0.0180	0.0266	0.02000	0	90.0	10	400	0	0	
Pyrene	0.0160	0.0266	0.02000	0	80.0	10	400	0	0	

Qualifiers: B Analyte detected in the associated Method Blank J Analyte detected between MDL and RL ND Not Detected at the Method Detection Limit RL Reporting Limit J Analyte detected between SDL and RL	DF Dilution Factor MDL Method Detection Limit R RPD outside accepted control limits S Spike Recovery outside control limits N Parameter not NELAC certified
----------------------------------------------------------------------------------------------------------------------------------------------------------------------------------------------------------------------------------	-------------------------------------------------------------------------------------------------------------------------------------------------------------------------

CLIENT: Half Associates, Inc
Work Order: 1405176
Project: Winnwood Ponds - Addison

ANALYTICAL QC SUMMARY REPORT

RunID: GCMS9_140527A

The QC data in batch 63726 applies to the following samples: 1405176-01B, 1405176-02B, 1405176-03B

Sample ID LCS-63726	Batch ID: 63726	TestNo: SW8270D	Units: mg/Kg
SampType: LCS	Run ID: GCMS9_140527A	Analysis Date: 5/27/2014 1:15:00 PM	Prep Date: 5/22/2014

Analyte	Result	RL	SPK value	Ref Val	%REC	LowLimit	HighLimit	%RPD	RPDLimit	Qual
Acenaphthene	1.31	0.0266	1.340	0	97.6	46	125			
Acenaphthylene	1.05	0.0266	1.340	0	78.3	44	125			
Anthracene	1.25	0.0266	1.340	0	93.2	53	125			
Benzo[a]anthracene	1.24	0.0266	1.340	0	92.3	52	125			
Benzo[a]pyrene	1.32	0.0266	1.340	0	98.6	50	125			
Benzo[b]fluoranthene	1.34	0.0266	1.340	0	99.9	45	125			
Benzo[g,h,i]perylene	1.32	0.0266	1.340	0	98.8	38	126			
Benzo[k]fluoranthene	1.31	0.0266	1.340	0	97.5	45	125			
Chrysene	1.31	0.0266	1.340	0	97.8	53	125			
Dibenz[a,h]anthracene	1.34	0.0266	1.340	0	100	41	125			
Fluoranthene	1.36	0.0266	1.340	0	101	54	125			
Fluorene	1.21	0.0266	1.340	0	90.4	49	125			
Indeno[1,2,3-cd]pyrene	1.35	0.0266	1.340	0	100	38	125			
Naphthalene	1.18	0.0266	1.340	0	88.2	40	125			
Phenanthrene	1.22	0.0266	1.340	0	91.0	50	125			
Pyrene	1.19	0.0266	1.340	0	89.0	46	125			
Surr: 2-Fluorobiphenyl	0.773		0.6670		116	60	135			
Surr: 4-Terphenyl-d14	0.707		0.6670		106	60	129			
Surr: Nitrobenzene-d5	0.727		0.6670		109	45	125			

Sample ID 1405185-09BMS	Batch ID: 63726	TestNo: SW8270D	Units: mg/Kg-dry
SampType: MS	Run ID: GCMS9_140527A	Analysis Date: 5/27/2014 1:39:00 PM	Prep Date: 5/22/2014

Analyte	Result	RL	SPK value	Ref Val	%REC	LowLimit	HighLimit	%RPD	RPDLimit	Qual
Acenaphthene	1.27	0.0292	1.469	0	86.5	46	125			
Acenaphthylene	1.05	0.0292	1.469	0	71.8	44	125			
Anthracene	1.29	0.0292	1.469	0	87.9	53	125			
Benzo[a]anthracene	1.29	0.0292	1.469	0	88.1	52	125			
Benzo[a]pyrene	1.40	0.0292	1.469	0	95.5	50	125			
Benzo[b]fluoranthene	1.49	0.0292	1.469	0	101	45	125			
Benzo[g,h,i]perylene	1.43	0.0292	1.469	0	97.5	38	126			
Benzo[k]fluoranthene	1.43	0.0292	1.469	0	97.1	45	125			
Chrysene	1.36	0.0292	1.469	0	92.3	53	125			
Dibenz[a,h]anthracene	1.30	0.0292	1.469	0	88.7	41	125			
Fluoranthene	1.61	0.0292	1.469	0	110	54	125			
Fluorene	1.13	0.0292	1.469	0	76.8	49	125			
Indeno[1,2,3-cd]pyrene	1.29	0.0292	1.469	0	88.1	38	125			
Naphthalene	1.19	0.0292	1.469	0	81.3	40	125			
Phenanthrene	1.27	0.0292	1.469	0	86.6	50	125			
Pyrene	1.30	0.0292	1.469	0	88.6	46	125			

Qualifiers:

B Analyte detected in the associated Method Blank	DF Dilution Factor
J Analyte detected between MDL and RL	MDL Method Detection Limit
ND Not Detected at the Method Detection Limit	R RPD outside accepted control limits
RL Reporting Limit	S Spike Recovery outside control limits
J Analyte detected between SDL and RL	N Parameter not NELAC certified

CLIENT: Halff Associates, Inc
Work Order: 1405176
Project: Winnwood Ponds - Addison

ANALYTICAL QC SUMMARY REPORT

RunID: GCMS9_140527A

Sample ID 1405185-09BMS	Batch ID: 63726	TestNo: SW8270D	Units: mg/Kg-dry							
SampType: MS	Run ID: GCMS9_140527A	Analysis Date: 5/27/2014 1:39:00 PM	Prep Date: 5/22/2014							
Analyte	Result	RL	SPK value	Ref Val	%REC	LowLimit	HighLimit	%RPD	RPDLimit	Qual
Surr: 2-Fluorobiphenyl	0.753		0.7310		103	60	135			
Surr: 4-Terphenyl-d14	0.804		0.7310		110	60	129			
Surr: Nitrobenzene-d5	0.709		0.7310		97.0	45	125			

Sample ID 1405185-09BMSD	Batch ID: 63726	TestNo: SW8270D	Units: mg/Kg-dry							
SampType: MSD	Run ID: GCMS9_140527A	Analysis Date: 5/27/2014 2:02:00 PM	Prep Date: 5/22/2014							
Analyte	Result	RL	SPK value	Ref Val	%REC	LowLimit	HighLimit	%RPD	RPDLimit	Qual
Acenaphthene	1.54	0.0302	1.521	0	101	46	125	19.4	30	
Acenaphthylene	1.22	0.0302	1.521	0	80.0	44	125	14.3	30	
Anthracene	1.47	0.0302	1.521	0	96.6	53	125	13.0	30	
Benzo[a]anthracene	1.50	0.0302	1.521	0	98.6	52	125	14.8	30	
Benzo[a]pyrene	1.62	0.0302	1.521	0	107	50	125	14.6	30	
Benzo[b]fluoranthene	1.60	0.0302	1.521	0	105	45	125	7.14	30	
Benzo[g,h,i]perylene	1.77	0.0302	1.521	0	117	38	126	21.3	30	
Benzo[k]fluoranthene	1.73	0.0302	1.521	0	114	45	125	19.4	30	
Chrysene	1.57	0.0302	1.521	0	103	53	125	14.8	30	
Dibenz[a,h]anthracene	1.78	0.0302	1.521	0	117	41	125	31.2	30	R
Fluoranthene	1.66	0.0302	1.521	0	109	54	125	2.71	30	
Fluorene	1.41	0.0302	1.521	0	92.4	49	125	22.0	30	
Indeno[1,2,3-cd]pyrene	1.75	0.0302	1.521	0	115	38	125	29.9	30	
Naphthalene	1.39	0.0302	1.521	0	91.1	40	125	14.9	30	
Phenanthrene	1.51	0.0302	1.521	0	99.0	50	125	16.9	30	
Pyrene	1.72	0.0302	1.521	0	113	46	125	28.0	30	
Surr: 2-Fluorobiphenyl	0.870		0.7573		115	60	135	0	0	
Surr: 4-Terphenyl-d14	1.04		0.7573		138	60	129	0	0	S
Surr: Nitrobenzene-d5	0.946		0.7573		125	45	125	0	0	

Sample ID MB-63726	Batch ID: 63726	TestNo: SW8270D	Units: mg/Kg							
SampType: MBLK	Run ID: GCMS9_140527A	Analysis Date: 5/27/2014 3:36:00 PM	Prep Date: 5/22/2014							
Analyte	Result	RL	SPK value	Ref Val	%REC	LowLimit	HighLimit	%RPD	RPDLimit	Qual
Acenaphthene	<0.0100	0.0266								
Acenaphthylene	<0.0100	0.0266								
Anthracene	<0.0100	0.0266								
Benzo[a]anthracene	<0.0100	0.0266								
Benzo[a]pyrene	<0.0100	0.0266								
Benzo[b]fluoranthene	<0.0100	0.0266								
Benzo[g,h,i]perylene	<0.0100	0.0266								
Benzo[k]fluoranthene	<0.0100	0.0266								
Chrysene	<0.0100	0.0266								

Qualifiers: B Analyte detected in the associated Method Blank DF Dilution Factor
J Analyte detected between MDL and RL MDL Method Detection Limit
ND Not Detected at the Method Detection Limit R RPD outside accepted control limits
RL Reporting Limit S Spike Recovery outside control limits
J Analyte detected between SDL and RL N Parameter not NELAC certified

CLIENT: Halff Associates, Inc
Work Order: 1405176
Project: Winnwood Ponds - Addison

ANALYTICAL QC SUMMARY REPORT

RunID: GCMS9_140527A

Sample ID MB-63726	Batch ID: 63726	TestNo: SW8270D	Units: mg/Kg
SampType: MBLK	Run ID: GCMS9_140527A	Analysis Date: 5/27/2014 3:36:00 PM	Prep Date: 5/22/2014

Analyte	Result	RL	SPK value	Ref Val	%REC	LowLimit	HighLimit	%RPD	RPDLimit	Qual
Dibenz[a,h]anthracene	<0.0100	0.0266								
Fluoranthene	<0.0100	0.0266								
Fluorene	<0.0100	0.0266								
Indeno[1,2,3-cd]pyrene	<0.0100	0.0266								
Naphthalene	<0.0100	0.0266								
Phenanthrene	<0.0100	0.0266								
Pyrene	<0.0100	0.0266								
Surr: 2-Fluorobiphenyl	0.880		0.6670		132	60	135			
Surr: 4-Terphenyl-d14	0.720		0.6670		108	60	129			
Surr: Nitrobenzene-d5	0.860		0.6670		129	45	125			S

Qualifiers: B Analyte detected in the associated Method Blank
 J Analyte detected between MDL and RL
 ND Not Detected at the Method Detection Limit
 RL Reporting Limit
 J Analyte detected between SDL and RL

DF Dilution Factor
 MDL Method Detection Limit
 R RPD outside accepted control limits
 S Spike Recovery outside control limits
 N Parameter not NELAC certified

CLIENT: Halff Associates, Inc
Work Order: 1405176
Project: Winnwood Ponds - Addison

ANALYTICAL QC SUMMARY REPORT

RunID: GCMS9_140527A

Sample ID ICV-140527	Batch ID: R73355	TestNo: SW8270D	Units: mg/Kg
SampType: ICV	Run ID: GCMS9_140527A	Analysis Date: 5/27/2014 12:52:00 PM	Prep Date:

Analyte	Result	RL	SPK value	Ref Val	%REC	LowLimit	HighLimit	%RPD	RPDLimit	Qual
Acenaphthene	3.65	0.0266	4.000	0	91.2	80	120			
Acenaphthylene	4.04	0.0266	4.000	0	101	80	120			
Anthracene	4.05	0.0266	4.000	0	101	80	120			
Benzo[a]anthracene	3.73	0.0266	4.000	0	93.4	80	120			
Benzo[a]pyrene	4.18	0.0266	4.000	0	104	80	120			
Benzo[b]fluoranthene	4.10	0.0266	4.000	0	103	80	120			
Benzo[g,h,i]perylene	4.08	0.0266	4.000	0	102	80	120			
Benzo[k]fluoranthene	3.96	0.0266	4.000	0	99.1	80	120			
Chrysene	3.69	0.0266	4.000	0	92.4	80	120			
Dibenz[a,h]anthracene	4.11	0.0266	4.000	0	103	80	120			
Fluoranthene	4.13	0.0266	4.000	0	103	80	120			
Fluorene	3.62	0.0266	4.000	0	90.4	80	120			
Indeno[1,2,3-cd]pyrene	4.12	0.0266	4.000	0	103	80	120			
Naphthalene	3.92	0.0266	4.000	0	98.0	80	120			
Phenanthrene	3.83	0.0266	4.000	0	95.7	80	120			
Pyrene	3.84	0.0266	4.000	0	96.1	80	120			
Surr: 2-Fluorobiphenyl	3.48		4.000		87.0	80	120			
Surr: 4-Terphenyl-d14	3.75		4.000		93.8	80	120			
Surr: Nitrobenzene-d5	4.11		4.000		103	80	120			

Qualifiers:	B Analyte detected in the associated Method Blank	DF Dilution Factor	
	J Analyte detected between MDL and RL	MDL Method Detection Limit	
	ND Not Detected at the Method Detection Limit	R RPD outside accepted control limits	
	RL Reporting Limit	S Spike Recovery outside control limits	
	J Analyte detected between SDL and RL	N Parameter not NELAC certified	

CLIENT: Halff Associates, Inc
Work Order: 1405176
Project: Winnwood Ponds - Addison

ANALYTICAL QC SUMMARY REPORT

RunID: PMOIST_140525F

The QC data in batch 63769 applies to the following samples: 1405176-01C, 1405176-02C, 1405176-03C

Sample ID	1405257-02A-DUP	Batch ID:	63769	TestNo:	D2216	Units:	WT%			
SampType:	DUP	Run ID:	PMOIST_140525F	Analysis Date:	5/26/2014 10:12:00 AM	Prep Date:	5/25/2014			
Analyte	Result	RL	SPK value	Ref Val	%REC	LowLimit	HighLimit	%RPD	RPDLimit	Qual
Percent Moisture	26.5	0	0	24.98				5.76	30	

Qualifiers:	B Analyte detected in the associated Method Blank	DF Dilution Factor
	J Analyte detected between MDL and RL	MDL Method Detection Limit
	ND Not Detected at the Method Detection Limit	R RPD outside accepted control limits
	RL Reporting Limit	S Spike Recovery outside control limits
	J Analyte detected between SDL and RL	N Parameter not NELAC certified

CLIENT: Half Associates, Inc
Work Order: 1405176
Project: Winnwood Ponds - Addison

MQL SUMMARY REPORT

TestNo: SW8270D	MDL	MQL			
Analyte	mg/Kg	mg/Kg			
1,2,4-Trichlorobenzene	0.0100	0.0266	Chrysene	0.0100	0.0266
1,2-Dichlorobenzene	0.0100	0.0266	Dibenz[a,h]anthracene	0.0100	0.0266
1,3-Dichlorobenzene	0.0100	0.0266	Dibenzofuran	0.0100	0.0266
1,4-Dichlorobenzene	0.0100	0.0266	Diethyl phthalate	0.0400	0.0660
2,4,5-Trichlorophenol	0.0100	0.0266	Dimethyl phthalate	0.0400	0.0660
2,4,6-Trichlorophenol	0.0100	0.0266	Di-n-butyl phthalate	0.0400	0.0660
2,4-Dichlorophenol	0.0100	0.0266	Di-n-octyl phthalate	0.0400	0.0660
2,4-Dimethylphenol	0.0100	0.0266	Fluoranthene	0.0100	0.0266
2,4-Dinitrophenol	0.0500	0.132	Fluorene	0.0100	0.0266
2,4-Dinitrotoluene	0.0100	0.0266	Hexachlorobenzene	0.0100	0.0266
2,6-Dichlorophenol	0.0100	0.0266	Hexachlorobutadiene	0.0100	0.0266
2,6-Dinitrotoluene	0.0100	0.0266	Hexachlorocyclopentadiene	0.0300	0.0660
2-Chloronaphthalene	0.0100	0.0266	Hexachloroethane	0.0100	0.0266
2-Chlorophenol	0.0100	0.0266	Indeno[1,2,3-cd]pyrene	0.0100	0.0266
2-Methylnaphthalene	0.0100	0.0266	Isophorone	0.0300	0.0660
2-Methylphenol	0.0100	0.0266	Naphthalene	0.0100	0.0266
2-Nitroaniline	0.0100	0.0266	Nitrobenzene	0.0100	0.0266
2-Nitrophenol	0.0100	0.0266	N-Nitrosodiethylamine	0.0100	0.0266
3,3'-Dichlorobenzidine	0.0100	0.0266	N-Nitrosodi-n-propylamine	0.0100	0.0266
3-Nitroaniline	0.0100	0.0266	N-Nitrosodiphenylamine	0.0100	0.0266
4,6-Dinitro-2-methylphenol	0.0300	0.0660	Pentachlorophenol	0.0100	0.0266
4-Bromophenyl phenyl ether	0.0100	0.0266	Phenanthrene	0.0100	0.0266
4-Chloro-3-methylphenol	0.0100	0.0266	Phenol	0.0100	0.0266
4-Chloroaniline	0.0300	0.0660	Pyrene	0.0100	0.0266
4-Chlorophenyl phenyl ether	0.0100	0.0266			
4-Methylphenol	0.0200	0.0266			
4-Nitroaniline	0.0100	0.0266			
4-Nitrophenol	0.0500	0.132			
Acenaphthene	0.0100	0.0266			
Acenaphthylene	0.0100	0.0266			
Aniline	0.0100	0.0266			
Anthracene	0.0100	0.0266			
Benzo[a]anthracene	0.0100	0.0266			
Benzo[a]pyrene	0.0100	0.0266			
Benzo[b]fluoranthene	0.0100	0.0266			
Benzo[g,h,i]perylene	0.0100	0.0266			
Benzo[k]fluoranthene	0.0100	0.0266			
Benzyl alcohol	0.0100	0.0660			
Bis(2-chloroethoxy)methane	0.0100	0.0266			
Bis(2-chloroethyl)ether	0.0100	0.0266			
Bis(2-chloroisopropyl)ether	0.0100	0.0266			
Bis(2-ethylhexyl)phthalate	0.0300	0.0660			
Butyl benzyl phthalate	0.0400	0.0660			
Carbazole	0.0100	0.0266			

Qualifiers: MQL -Method Quantitation Limit as defined by TRRP
 MDL -Method Detection Limit as defined by TRRP

CLIENT: Halff Associates, Inc
Work Order: 1405176
Project: Winnwood Ponds - Addison

MQL SUMMARY REPORT

TestNo: SW8270D	MDL	ML
Analyte	mg/Kg	mg/Kg
4,4'-DDD	0.00200	0.00600
4,4'-DDE	0.00200	0.00600
4,4'-DDT	0.00200	0.00600
Aldrin	0.00200	0.00600
alpha-BHC	0.00200	0.00600
alpha-Chlordane	0.00200	0.00600
beta-BHC	0.00200	0.00600
Chlordane	0.0100	0.0300
delta-BHC	0.00200	0.00600
Dieldrin	0.00200	0.00600
Endosulfan I	0.00200	0.00600
Endosulfan II	0.00200	0.00600
Endosulfan sulfate	0.00200	0.00600
Endrin	0.00200	0.00600
Endrin aldehyde	0.00200	0.00600
Endrin ketone	0.00200	0.00600
gamma-BHC	0.00200	0.00600
gamma-Chlordane	0.00200	0.00600
Heptachlor	0.00200	0.00600
Heptachlor epoxide	0.00200	0.00600
Methoxychlor	0.00200	0.00600
Toxaphene	0.0800	0.250

TestNo: SW8270D	MDL	ML
Analyte	mg/Kg	mg/Kg
Aroclor 1016	0.0250	0.0500
Aroclor 1221	0.0250	0.0500
Aroclor 1232	0.0250	0.0500
Aroclor 1242	0.0250	0.0500
Aroclor 1248	0.0250	0.0500
Aroclor 1254	0.0250	0.0500
Aroclor 1260	0.0250	0.0500

TestNo: SW7471B	MDL	ML
Analyte	mg/Kg	mg/Kg
Mercury	0.0160	0.0400

TestNo: SW6020A	MDL	ML
Analyte	mg/Kg	mg/Kg
Arsenic	0.500	1.00
Cadmium	0.100	0.300
Chromium	0.500	2.00
Copper	0.500	2.00
Lead	0.100	0.300
Nickel	0.500	2.00
Selenium	0.150	0.500
Silver	0.100	0.200
Zinc	1.00	2.50

Qualifiers: MQL -Method Quantitation Limit as defined by TRRP
MDL -Method Detection Limit as defined by TRRP

Attachment B

Section 404 – Letter of Permission

- 1. Application*
- 2. Letter of Permission*

Insert Letter of Permission

17. DIRECTIONS TO THE SITE

From Fort Worth, Texas, head east on SH-121 (Airport Fwy) towards Dallas. Exit SH-161 (President George Bush Turnpike) and head north. Exit and turn right onto Belt Line Road and proceed east. Continue east on Belt Line Road for approximately 6.5 miles passing the Dallas North Tollway. Project area lies south of Belt Line Road between Oaks North Drive and Winnwood Road in Addison, Texas.

18. Nature of Activity (Description of project, include all features)

The proposed project would consist of minor dredging activities and removal of approximately 4,000 to 5,000 cubic yards of sediment within three on channel surface impoundments located within Winnwood Park

19. Project Purpose (Describe the reason or purpose of the project, see instructions)

The Town of Addison has proposed the removal of accumulated sediment to enhance water quality, flood control, and improve the aesthetic value of the three on channel surface impoundments located within Winnwood Park

USE BLOCKS 20-23 IF DREDGED AND/OR FILL MATERIAL IS TO BE DISCHARGED

20. Reason(s) for Discharge

Dredged and/or fill material will not be discharged in the scope of the proposed action

21. Type(s) of Material Being Discharged and the Amount of Each Type in Cubic Yards:

Type	Type	Type
Amount in Cubic Yards	Amount in Cubic Yards	Amount in Cubic Yards

22. Surface Area in Acres of Wetlands or Other Waters Filled (see instructions)

Acres No wetlands or other waters will be filled within the scope of the proposed action
or
Linear Feet

23. Description of Avoidance, Minimization, and Compensation (see instructions)

Due to the fact, that no waters of the United States should be permanently adversely affected by the proposed action compensatory mitigation should be unnecessary.

24. Is Any Portion of the Work Already Complete? Yes No IF YES, DESCRIBE THE COMPLETED WORK

-The sediments within the Winnwood Ponds have been sampled and analyzed

-Presence/ Absence surveys for threatened and endangered aquatic fauna have been completed within the Winnwood Ponds

25. Addresses of Adjoining Property Owners, Lessees, Etc., Whose Property Adjoins the Waterbody (if more than can be entered here, please attach a supplemental list).

a. Address- This information is for individual permits and is not a requirement for the letter of permission procedure

City - State - Zip -

b. Address-

City - State - Zip -

c. Address-

City - State - Zip -

d. Address-

City - State - Zip -

e. Address-

City - State - Zip -

26. List of Other Certificates or Approvals/Denials received from other Federal, State, or Local Agencies for Work Described in This Application.

AGENCY	TYPE APPROVAL*	IDENTIFICATION NUMBER	DATE APPLIED	DATE APPROVED	DATE DENIED

* Would include but is not restricted to zoning, building, and flood plain permits

27. Application is hereby made for permit or permits to authorize the work described in this application. I certify that this information in this application is complete and accurate. I further certify that I possess the authority to undertake the work described herein or am acting as the duly authorized agent of the applicant.

_____	_____	_____	_____
SIGNATURE OF APPLICANT	DATE	SIGNATURE OF AGENT	DATE

2014-10-30

The Application must be signed by the person who desires to undertake the proposed activity (applicant) or it may be signed by a duly authorized agent if the statement in block 11 has been filled out and signed.

18 U.S.C. Section 1001 provides that: Whoever, in any manner within the jurisdiction of any department or agency of the United States knowingly and willfully falsifies, conceals, or covers up any trick, scheme, or disguises a material fact or makes any false, fictitious or fraudulent statements or representations or makes or uses any false writing or document knowing same to contain any false, fictitious or fraudulent statements or entry, shall be fined not more than \$10,000 or imprisoned not more than five years or both.

Attachment C

Record Drawings – Creek System Improvements 1989

B11-5

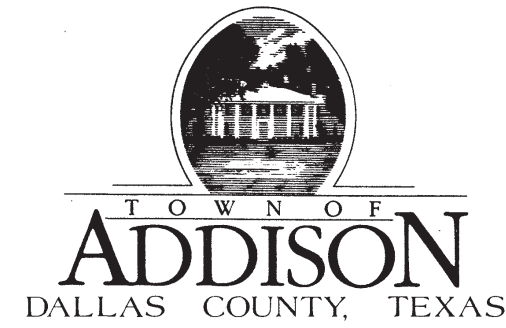
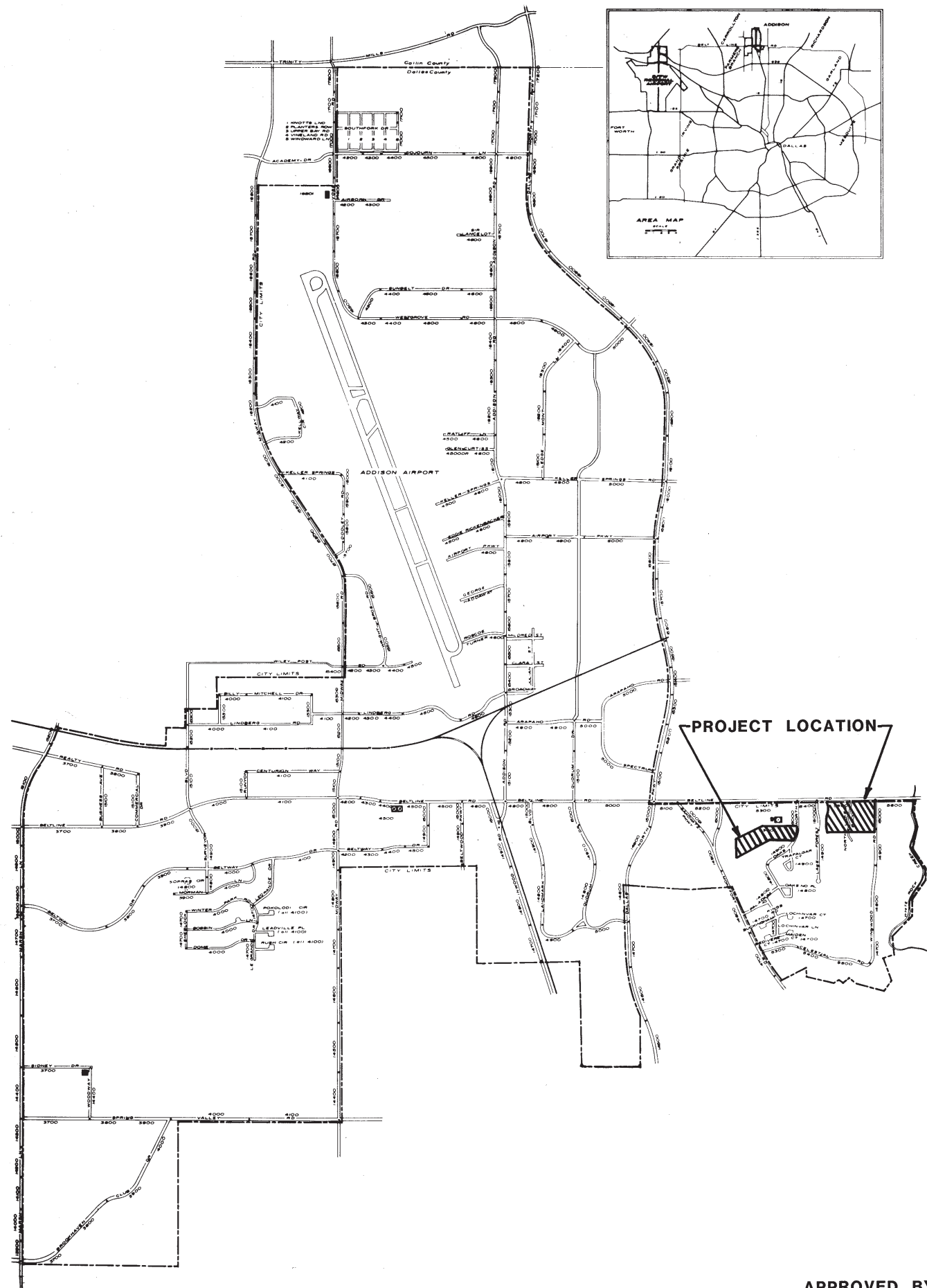

CONSTRUCTION PLANS FOR

CREEK SYSTEM IMPROVEMENTS

MAYOR
LYNN SPRUILL

COUNCIL MEMBERS :
JIM DUFFY
RICHARD RODER
JOHN NOLAN
JOHN BRANCH
RILEY REINKER

CITY MANAGER :
RON WHITEHEAD

DIRECTOR OF LANDSCAPE :
SLADE STRICKLAND

INDEX TO DRAWINGS

SHEET NO.	DESCRIPTION
1.	COVER SHEET
2.	VICINITY MAP
3.	EXISTING AND PROPOSED HYDRAULIC PROFILE
4.	WINNWOOD PARK - EAST POND LAYOUT
5.	WINNWOOD PARK - WEST POND LAYOUT
6.	WINNWOOD PARK - PUMP STATION PLAN AND SECTION
7.	WINNWOOD PARK - PUMP STATION DETAILS
8.	WINNWOOD PARK - MISCELLANEOUS DETAILS
9.	CROSS SECTIONS - WINNWOOD PARK EAST
10.	CROSS SECTIONS - WINNWOOD PARK WEST
11.	CROSS SECTIONS - WINNWOOD PARK WEST
12.	FINANCE CENTER - POND LAYOUT
13.	TOWN HALL - POND LAYOUT
14.	FINANCE CENTER - PUMP STATION SITE PLAN
15.	FINANCE CENTER - PUMP STATION PLAN/SECTION
16.	FINANCE CENTER - PUMP STATION DETAILS
17.	FINANCE CENTER - MISCELLANEOUS DETAILS
18.	CROSS SECTIONS - FINANCE CENTER
19.	CROSS SECTIONS - FINANCE CENTER
20.	CROSS SECTIONS - TOWN HALL
21.	TOWN HALL/OAKS NORTH DRIVE - DITCH IMPROVEMENTS
22.	ELECTRICAL - TYP. PUMP STATION
23.	ELECTRICAL - SCHEMATICS & DETAILS

APPROVED BY: _____ DATE: _____
D. LYNN SPRUILL, MAYOR

GINN, INC.
Consulting Engineers Dallas, Texas

B11-5



Randall C. Hill
1-20-89

TOWN HALL CREEK SYSTEM IMPROVEMENTS FULL

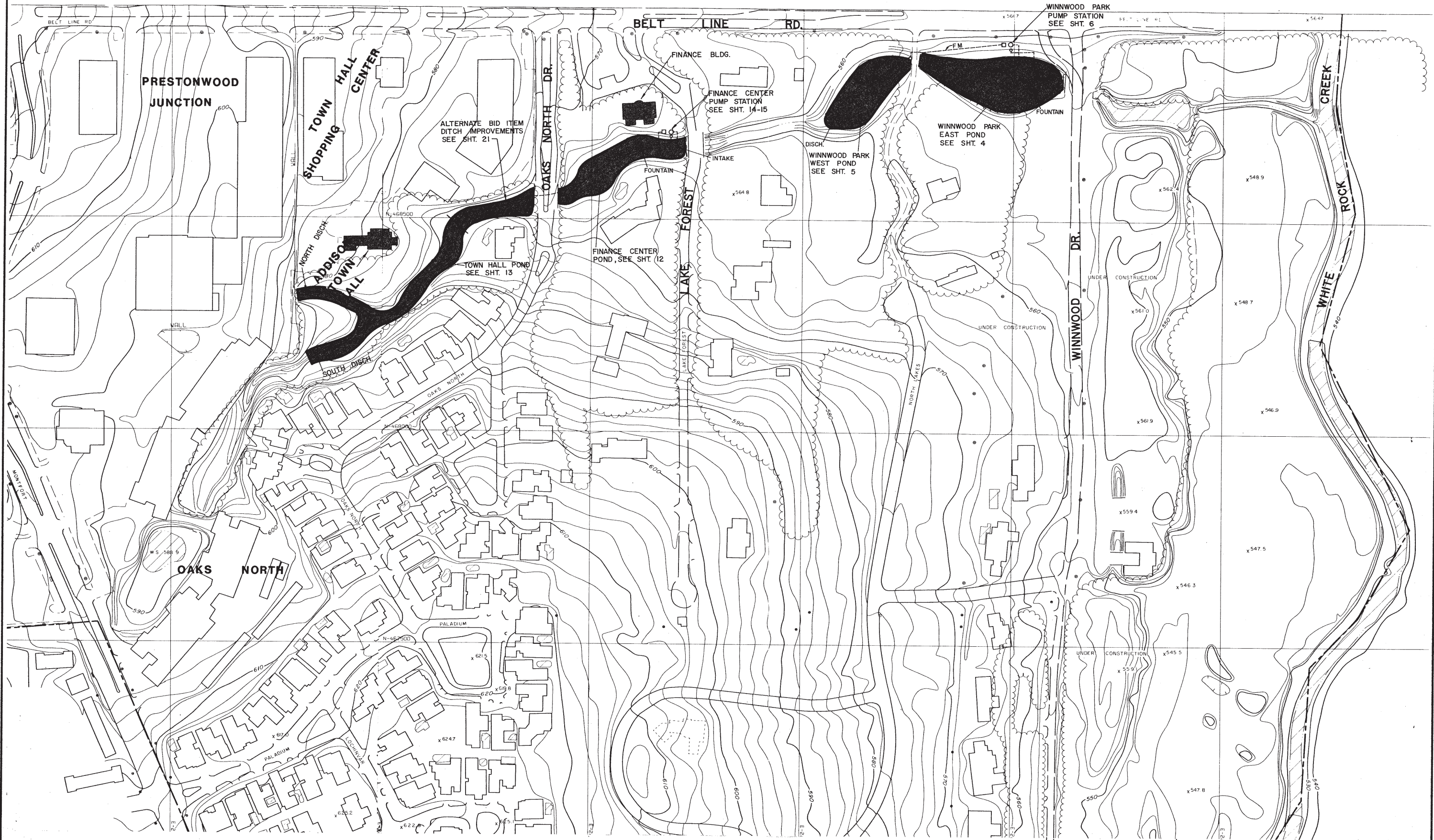

B.M. "□" on Eastmost SE corner parking area at SW corner of Town Hall
ELEV. = 580.77 (MSL)

B.M. "□" on W. curb Oaks North - 6' south of end of bridge
ELEV. = 567.64 (MSL)

B.M. "□" Cut On Edge Of Concrete Porch Of Church At 5555 Celestial.
Elev. = 577.95 (M.S.L.)

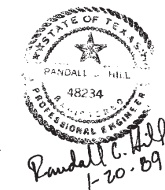

No.	Revision	By	Date
TOWN OF ADDISON DALLAS COUNTY, TEXAS CREEK SYSTEM IMPROVEMENTS			
VICINITY MAP			
GINN, INC. Consulting Engineers Dallas, Texas			
Designed - AFG	Drawn - CL	Date - DEC 1988	Job No. - 369
Approved - HWG	Checked - RCH	Scale - 1" = 100'	Sheet 2 Of 23

REC'D 3/28/89

FINAL SURVEY
 SURVEYED BY
 PLOTTED BY
 NOTE BOOK NO.
 TEMPLATE NO.
 AREAS CHECKED

ORIGINAL SURVEY
 SURVEYED BY
 PLOTTED BY
 NOTE BOOK NO.
 TEMPLATE NO.
 AREAS CHECKED

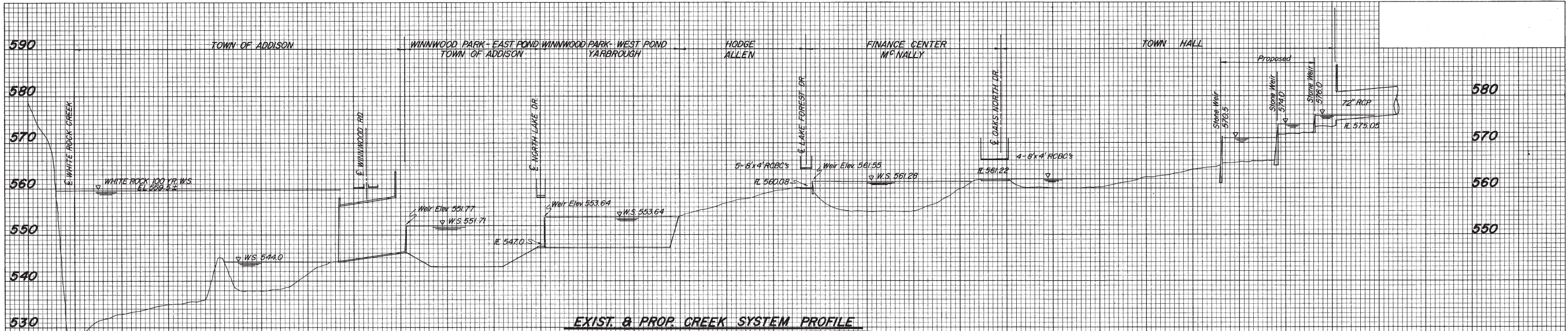

EXIST. & PROP. CREEK SYSTEM PROFILE

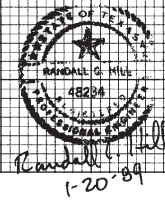

H-1

1-20-89

No.	Revision	By	Date
TOWN OF ADDISON DALLAS COUNTY, TEXAS CREEK SYSTEM IMPROVEMENTS EXIST & PROP HYDRAULIC PROFILE GINN, INC. Consulting Engineers Dallas, Texas			
Designed - RCH	Drawn - RLO	Date - OCT, 1988	Job No. - 369
Approved - HWG	Checked - RCH	Scale - H: 1"=100', V: 1"=5'	Sheet 3 of 23

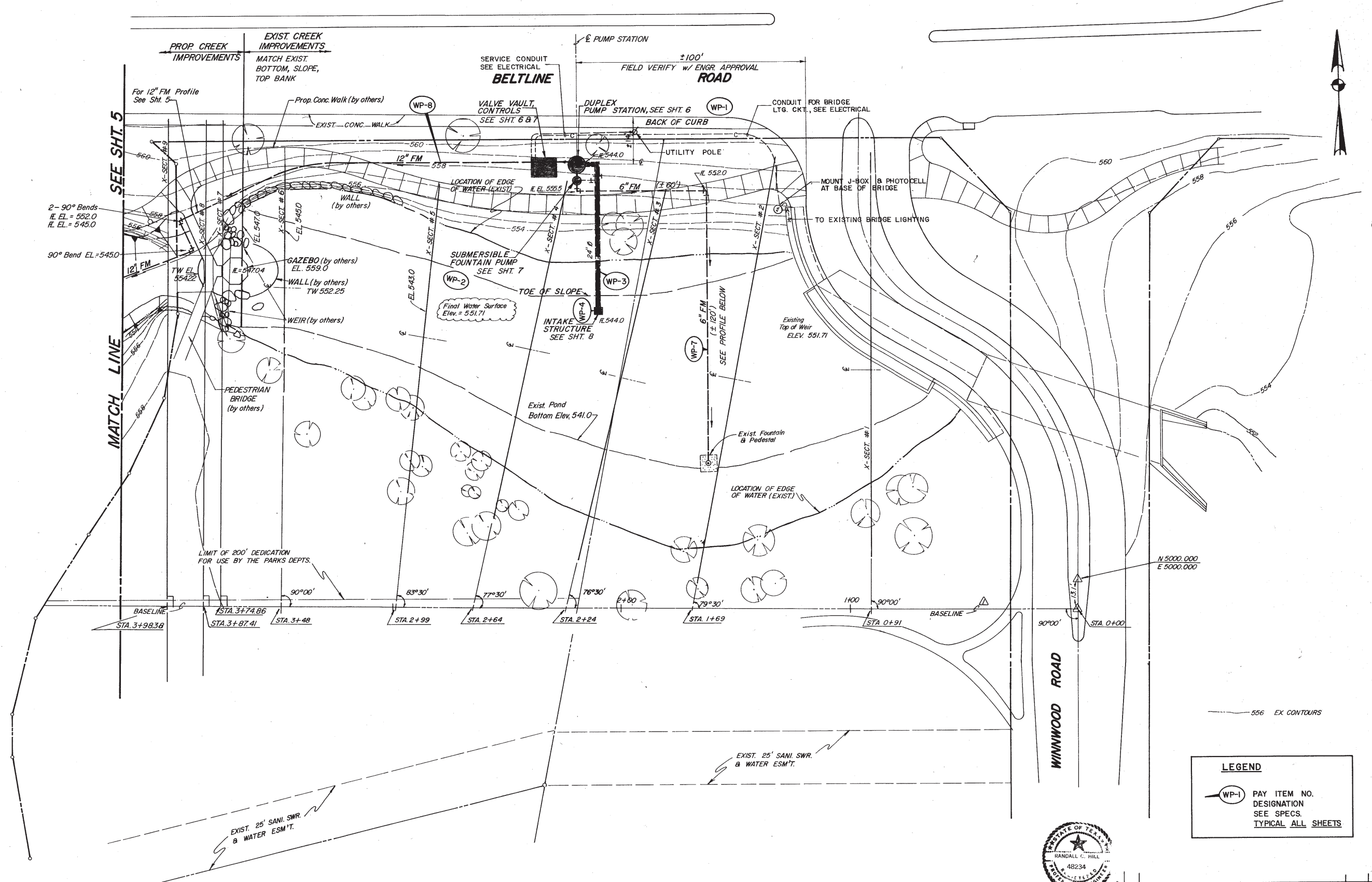

MATCH LINE SEE SHT. 5

2- 90° Bends
H. EL. = 552.0
H. EL. = 545.0

90° Bend EL = 545.0

MATCH LINE SEE SHT. 5

LEGEND

WP-1 PAY ITEM NO. DESIGNATION SEE SPECS. TYPICAL ALL SHEETS



Randall C. Hill
1-20-89

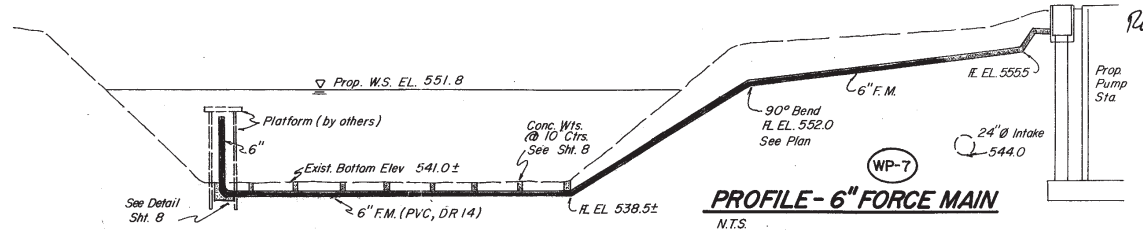

No.	Revision	By	Date

TOWN OF ADDISON
DALLAS COUNTY, TEXAS
CREEK SYSTEM IMPROVEMENTS
WINNWOOD PARK EAST POND LAYOUT
GINN, INC.
Consulting Engineers Dallas, Texas

Designed - RCH Drawn - RLO Date - OCT., 1988 Job No. - 369
Approved - HWG Checked - RCH Scale - 1" = 20' Sheet 4 of 23

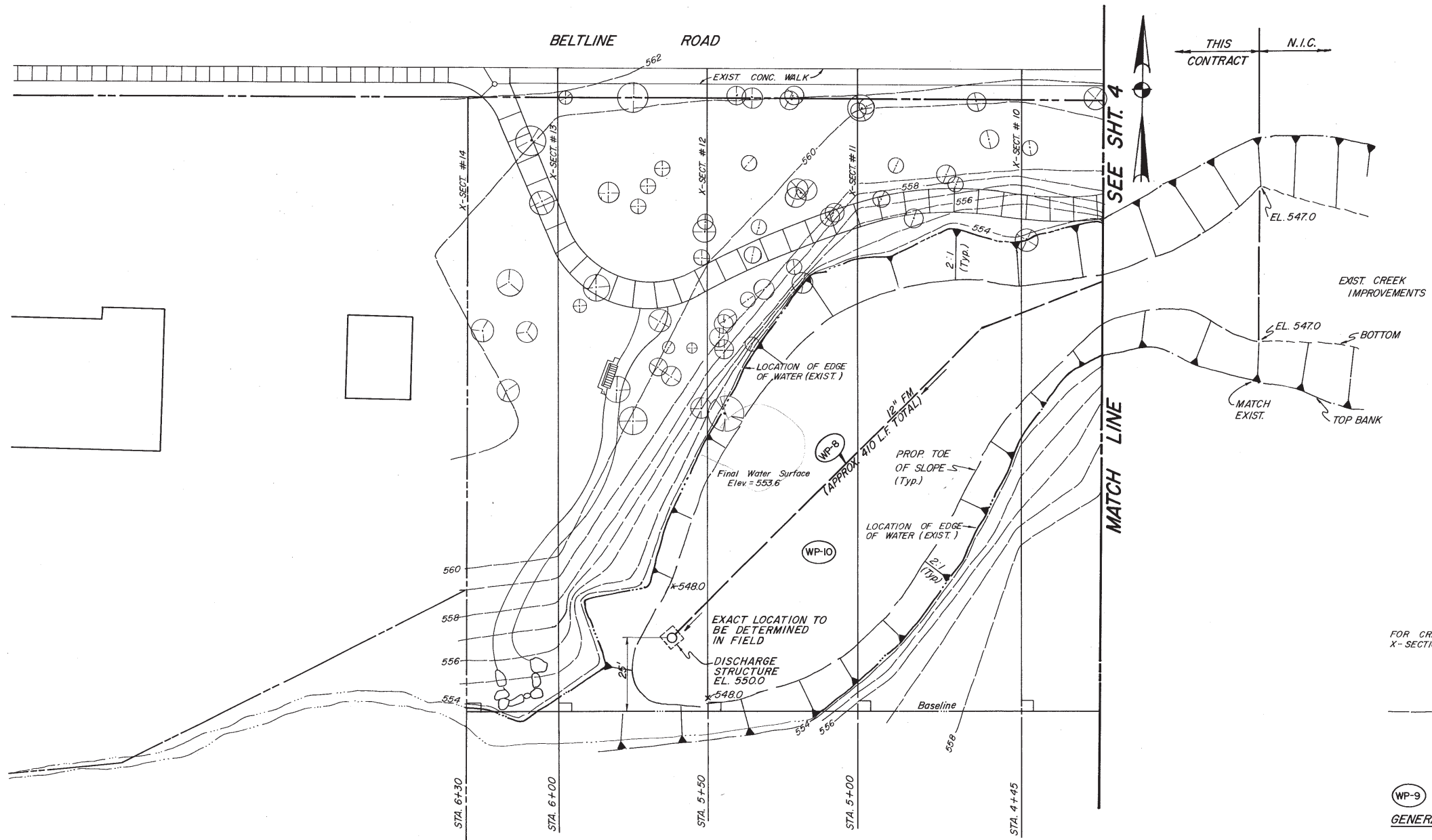

FOR CREEK IMPROVEMENTS USE X-SECTIONS SEE SHT. 9,10, & 11

556 EX. CONTOURS

WP-9

GENERAL NOTES: (REFERENCE CROSS-SECTION SHEETS)

1. Contractor Shall Drain Pond; Allow Adequate Time To Have Engineer Perform Cross Sections To Verify Existing Conditions Of Creek Bottom; And Then Contractor Shall Perform All Necessary Excavation Required To Dimensions, Lines And Grades As Shown On Plans.
2. Final Cross Sections Will Be Performed By Engineer For Use In Determining Final Quantities Of Excavation For Payment.
3. Quantities Provided For Bidding Purposes Were Estimates Only. Actual Quantities Will Be Basis For Payment.

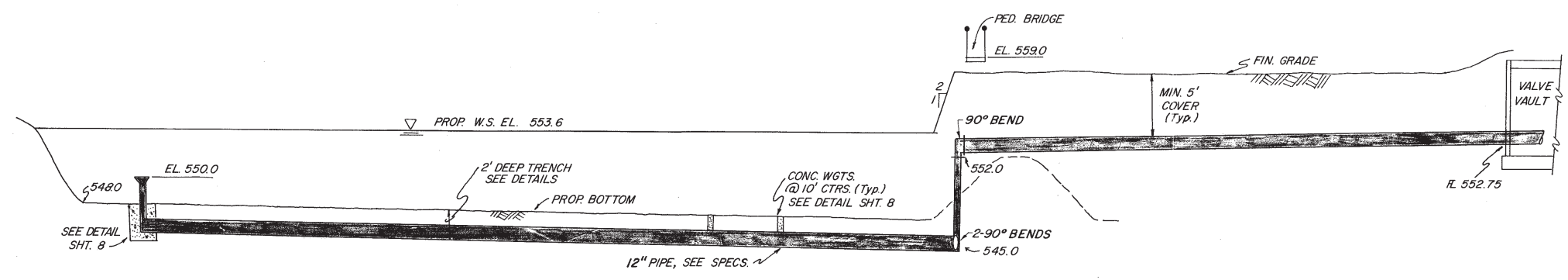

12" DIAM. (DISCHARGE) FORCE MAIN WP-8
N.T.S.

Professional Engineer Seal
Randall L. Hill
1-20-89

L-2

No.	Revision	By	Date
TOWN OF ADDISON DALLAS COUNTY, TEXAS CREEK SYSTEM IMPROVEMENTS WINNWOOD PARK WEST POND LAYOUT GINN, INC. Consulting Engineers Dallas, Texas			
Designed - RCH	Drawn - RLO	Date - OCT., 1988	Job No. - 369
Approved - HWG	Checked - RCH	Scale - 1" = 20'	Sheet 5 of 23

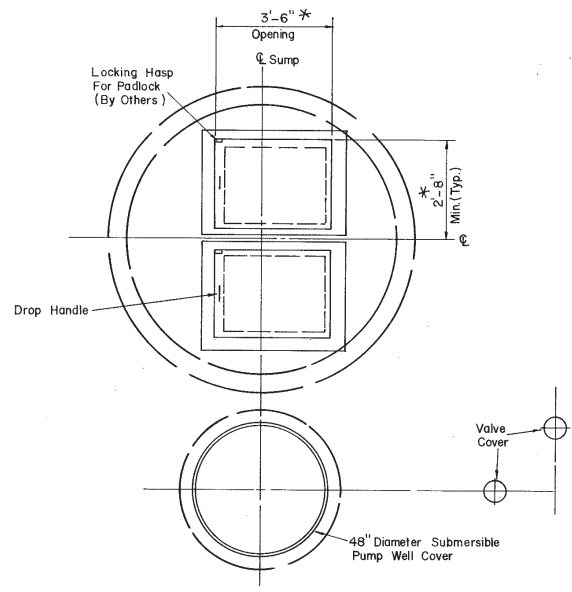

TOP VIEW
3/8" = 1'-0"
* DEPENDENT UPON PUMP MFG.

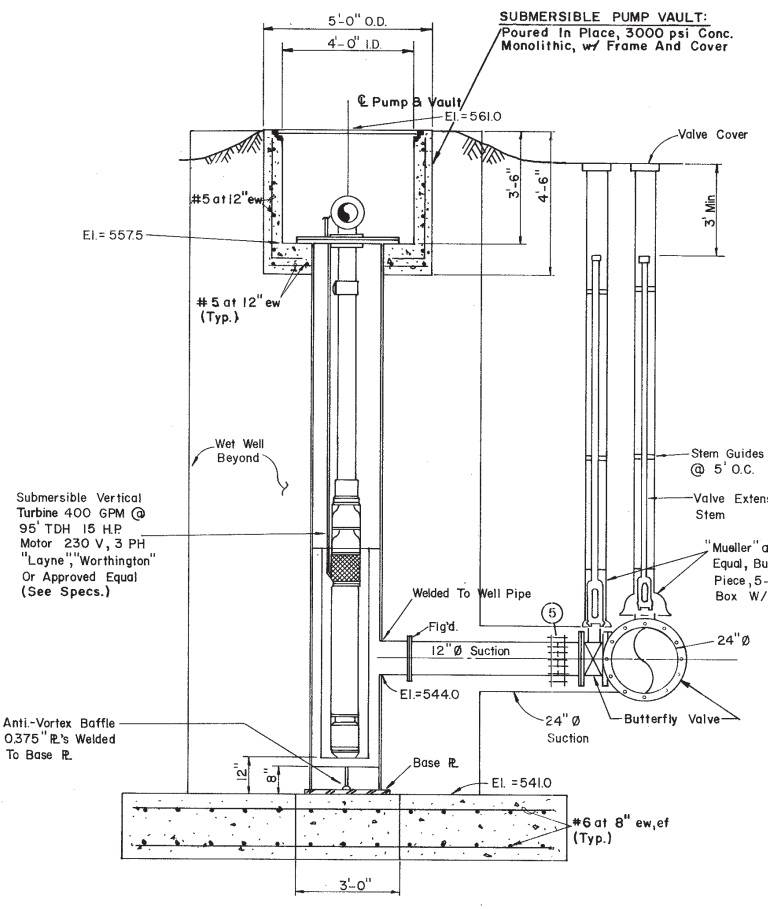

SECTION B

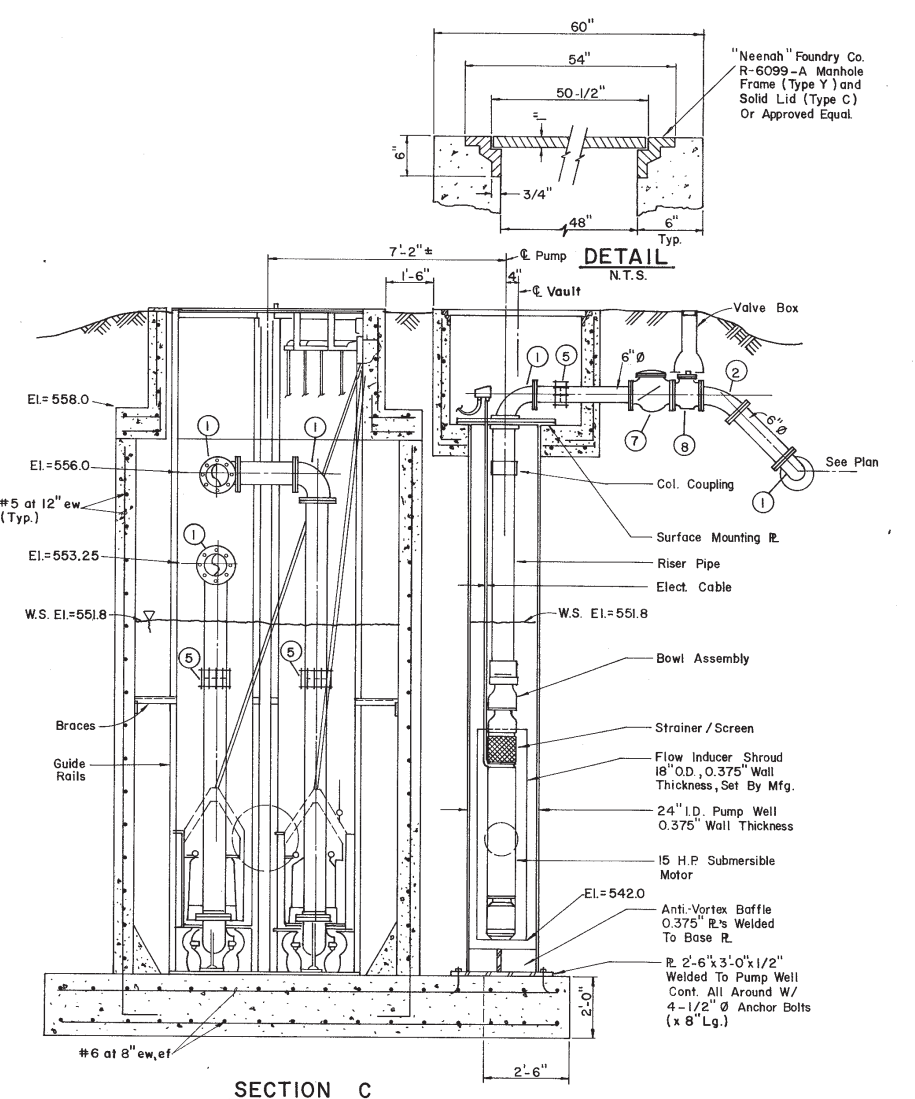

SECTION C

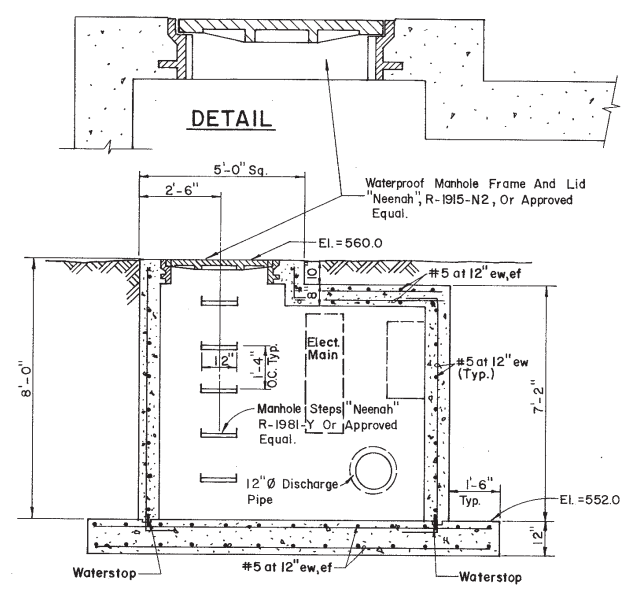

SECTION D

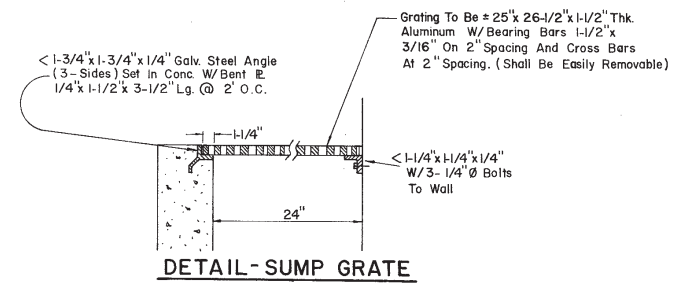

DETAIL - SUMP GRATE

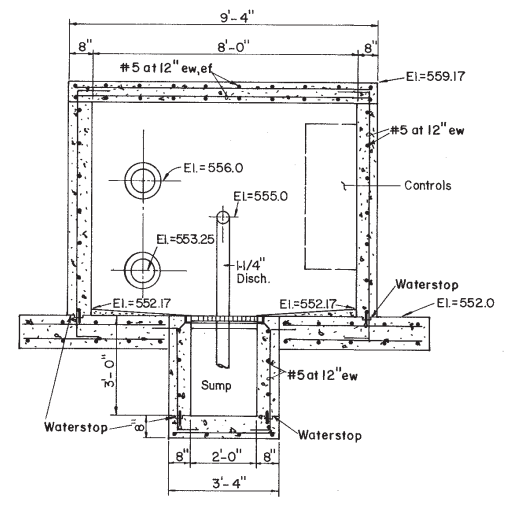

SECTION E

- LEGEND**
- ① 90° Bend (Flanged)
 - ② 45° Bend (Flanged)
 - ③ 8" x 8" x 8" Lateral (Flanged)
 - ④ 12" x 8" Reducer (Flanged)
 - ⑤ "Dresser" Type Coupling (Size Indicated)
 - ⑥ Cast in Place Wall Pipe (Fig. B & PE.)
 - ⑦ "Clow" F-1426, Or Approved Equal
 - ⑧ Check Valve (See Specs)
 - ⑨ Plug Valve (See Specs)
 - ⑩ 1-1/4" Check Valve
 - ⑪ 1-1/4" Gate Valve



No.	Revision	By	Date
TOWN OF ADDISON DALLAS COUNTY, TEXAS CREEK SYSTEM IMPROVEMENTS WINNWOOD PARK PUMP STATION DETAILS GINN, INC. Consulting Engineers Dallas, Texas			
Designed - AGF	Drawn - CL	Date - DEC. 1988	Job No. - 369
Approved - HWG	Checked - RCH	Scale - 3/8" = 1'-0"	Sheet 7 of 23

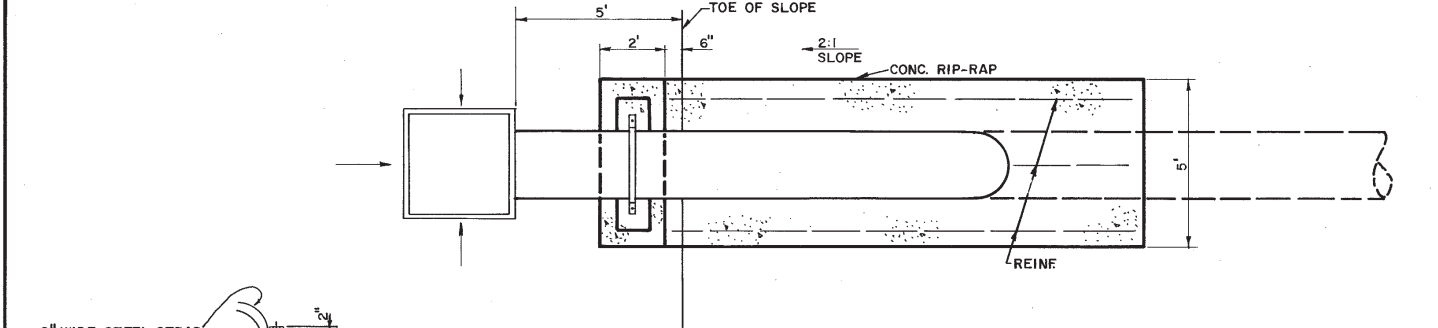

PLAN

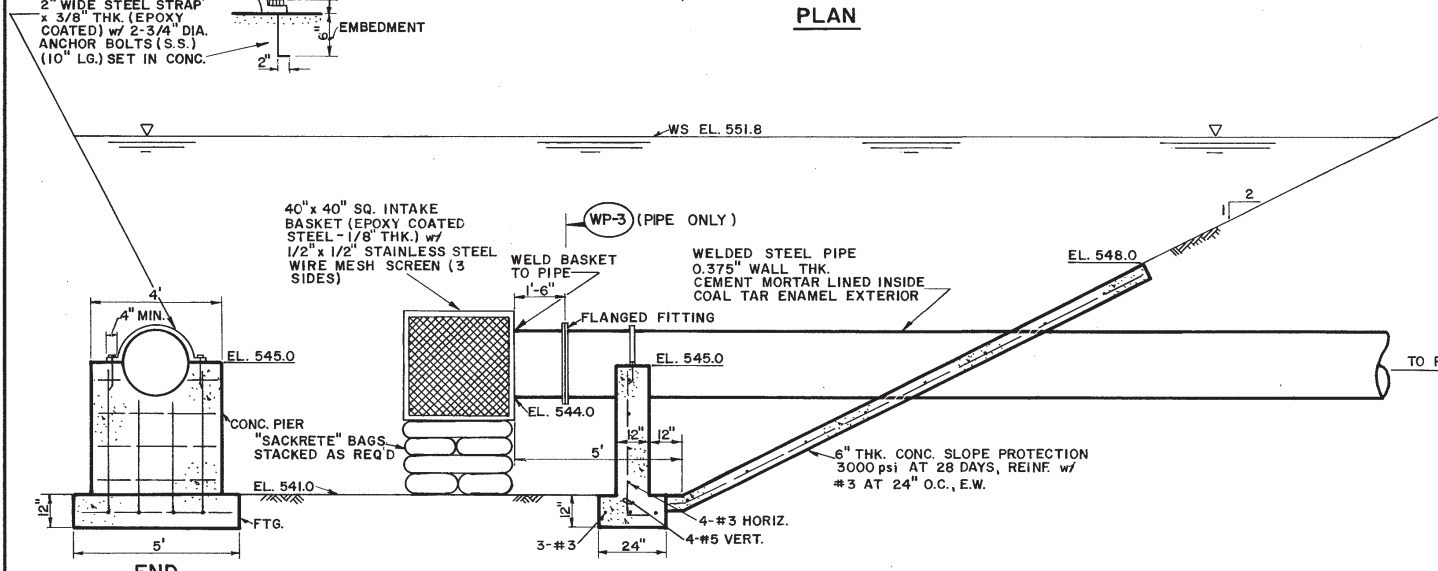

ELEVATION

INTAKE STRUCTURE DETAILS

SCALE: 3/8" = 1'-0"

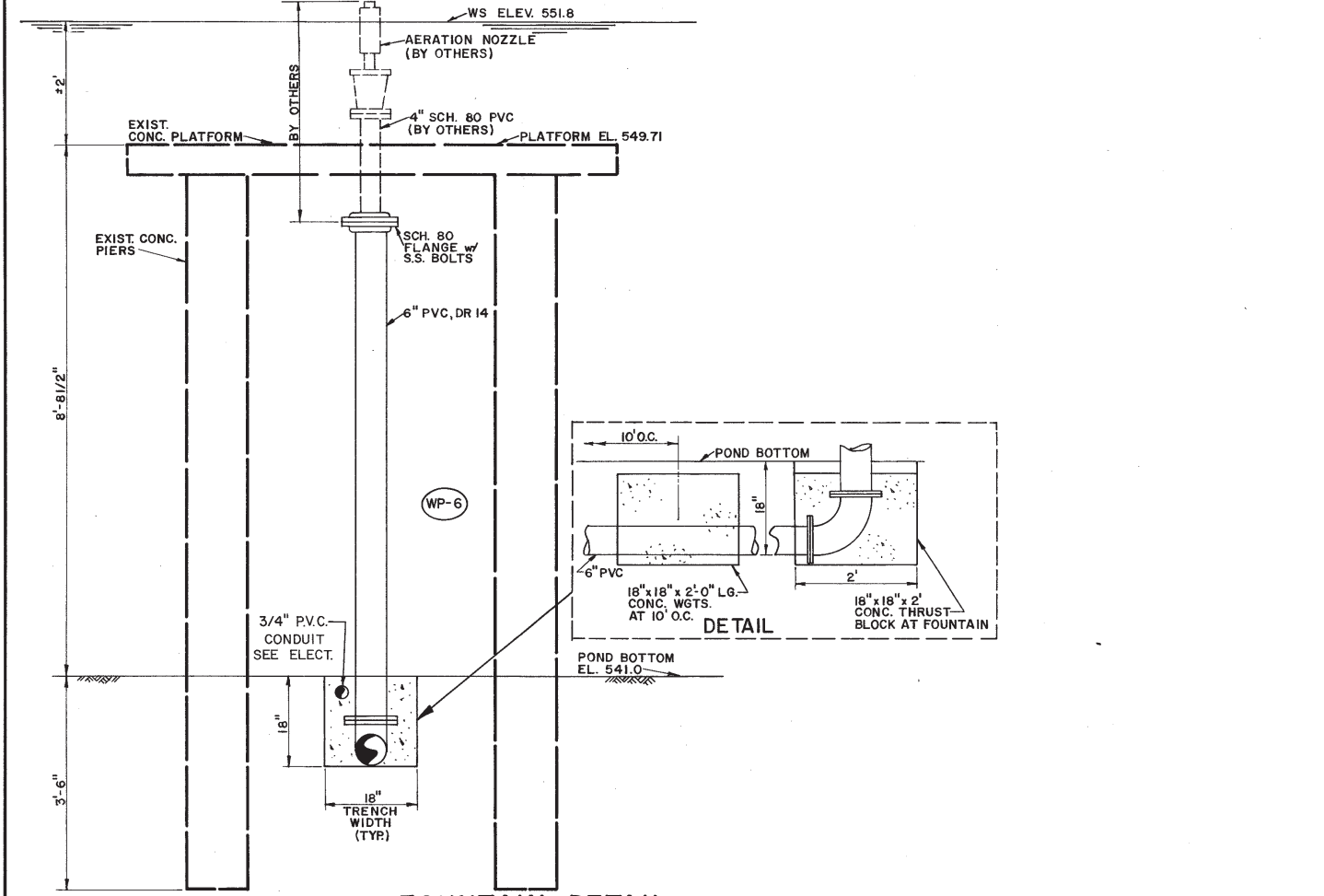

FOUNTAIN DETAIL

SCALE: 3/4" = 1'-0"

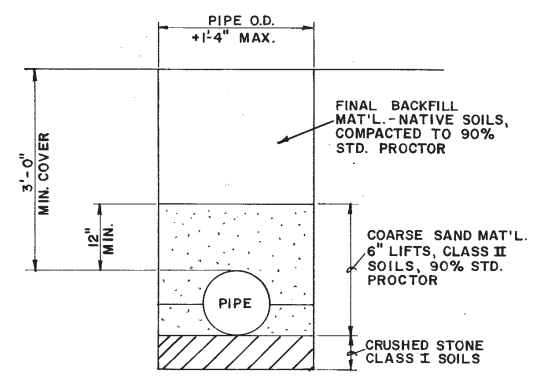

TYP. EMBEDMENT/BACKFILL DETAILS (FOR PIPE NOT SUBMERGED)

SCALE: 3/4" = 1'-0"

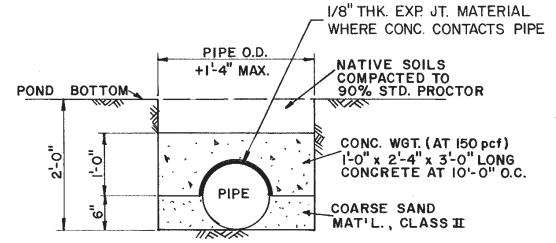

TYP. EMBEDMENT/BACKFILL DETAILS (FOR SUBMERGED PIPE)

SCALE: 3/4" = 1'-0"

12" DIA. DISCHARGE PIPE DETAILS

WP-8

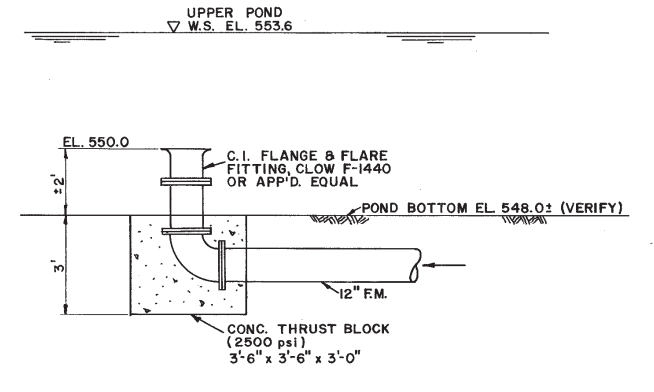

DISCHARGE STRUCTURE

WP-8

SCALE: 3/8" = 1'-0"

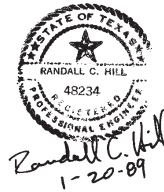

Randall C. Hill
1-20-89

No.	Revision	By	Date
TOWN OF ADDISON DALLAS COUNTY, TEXAS CREEK SYSTEM IMPROVEMENTS WINNWOOD PARK MISCELLANEOUS DETAILS GINN, INC. Consulting Engineers Dallas, Texas			
Designed - AGF	Drawn - DEM	Date - DEC. 1988	Job No. - 369
Approved - HWG	Checked - RCH	Scale - AS SHOWN	Sheet 8 of 23

FINAL SURVEY DATE
 SURVEYED BY
 PLOTTED BY
 NOTE BOOK NO.
 TEMPLATE NO.
 AREAS CHECKED

ORIGINAL SURVEY DATE
 SURVEYED BY
 PLOTTED BY
 NOTE BOOK NO.
 TEMPLATE NO.
 AREAS CHECKED

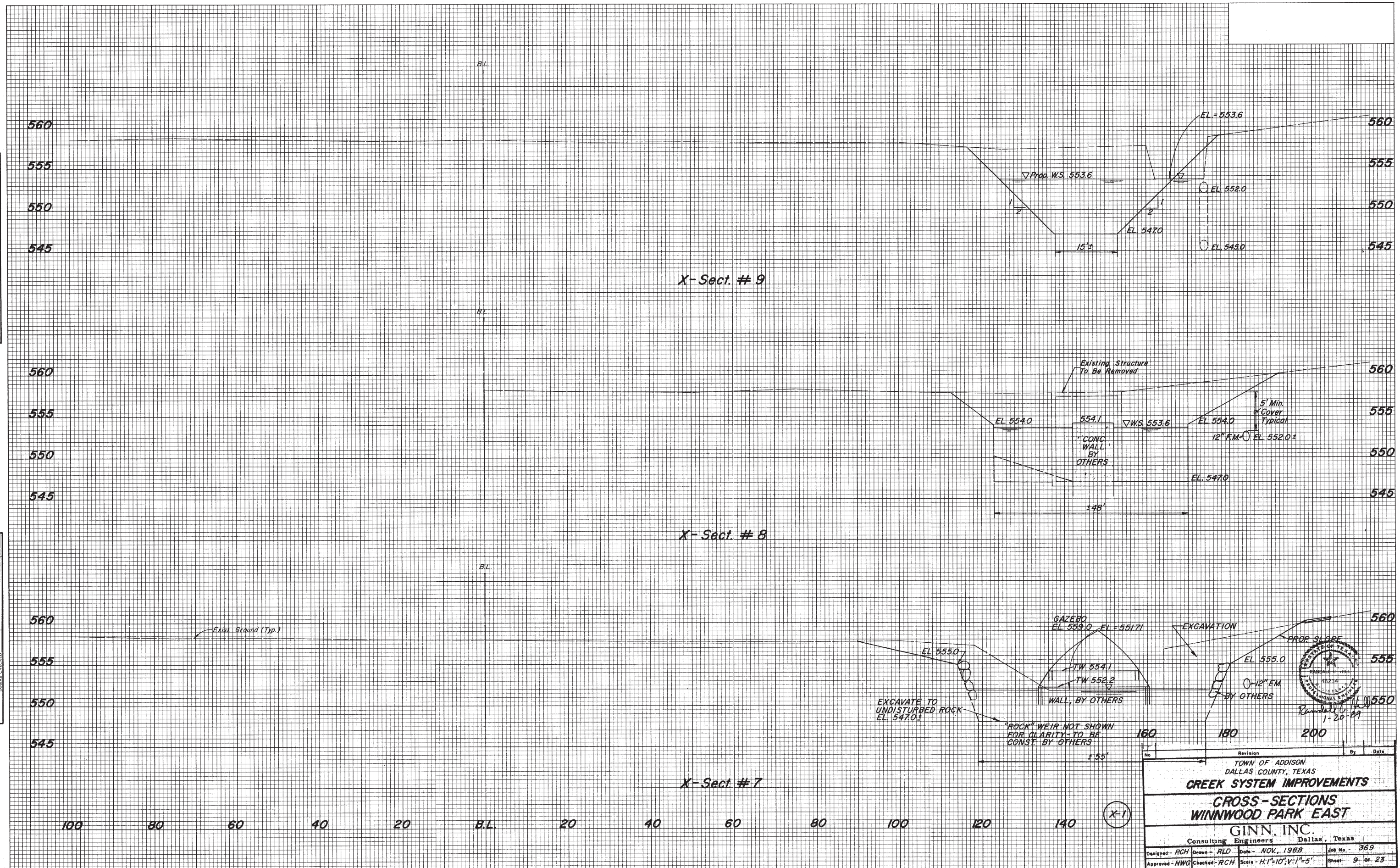

Revision		By	Date
TOWN OF ADDISON DALLAS COUNTY, TEXAS			
CREEK SYSTEM IMPROVEMENTS			
CROSS-SECTIONS WINNWOOD PARK EAST			
GINN, INC.			
Consulting Engineers Dallas, Texas			
Designed - RCH	Drawn - RLD	Date - NOV, 1988	Job No. - 369
Approved - HWG	Checked - RCH	Scale - H:1"=10'; V:1"=5'	Sheet - 9 of 23

DATE
BY
SURVEYED
TEMPLATE
NOTE BOOK
AREAS CHECKED

DATE
BY
ORIGINAL SURVEY
TEMPLATE
NOTE BOOK
AREAS CHECKED

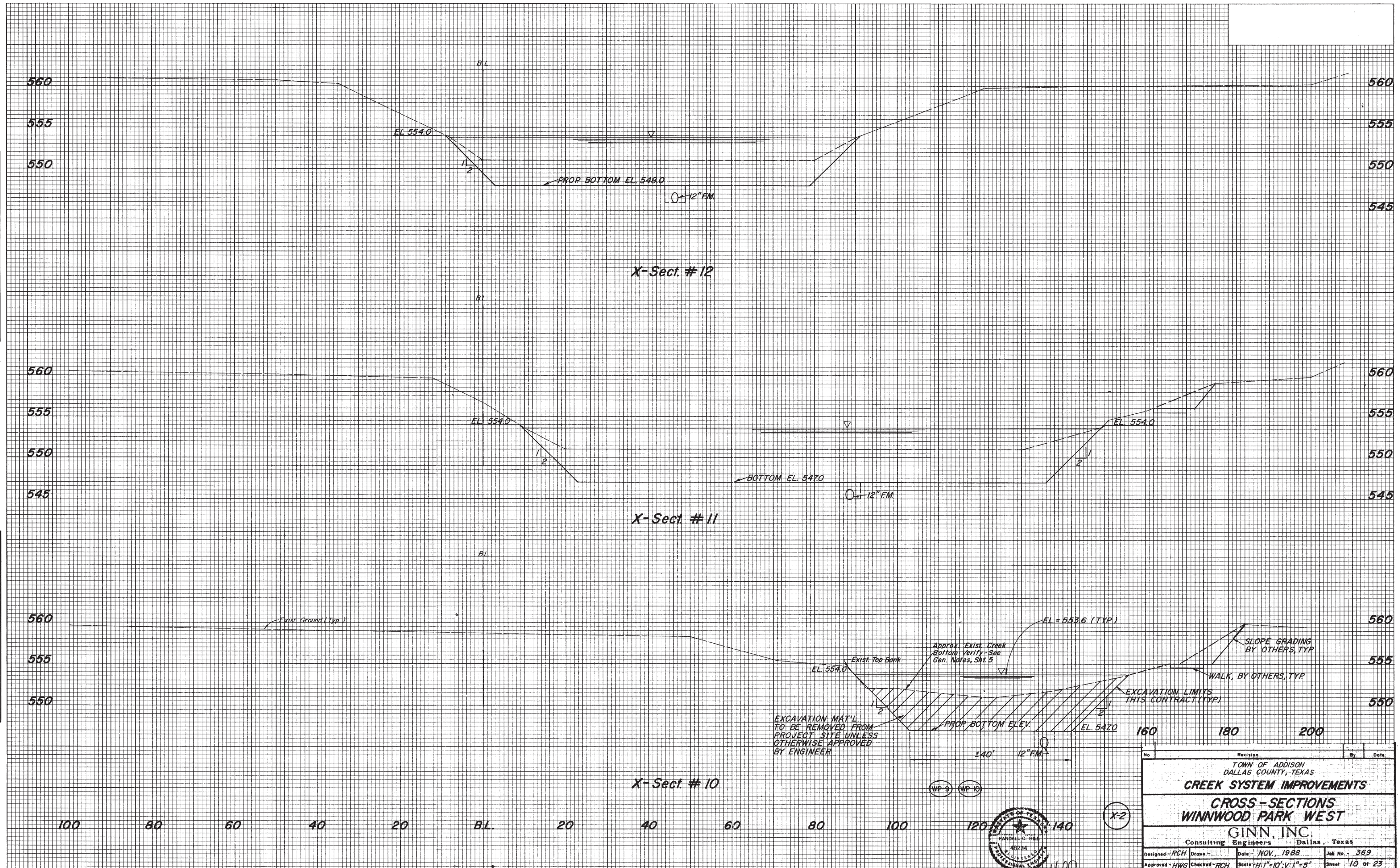

HIGHWAY FEDERAL AID SHEET
PLATE 3-FULL CROSS SECTION-FULL LINE
NOTED
PRINTED IN U.S.A.

WP-9 WP-10



Randall C. Hill
1-20-89

X-2

No.	Revision	By	Date
TOWN OF ADDISON DALLAS COUNTY, TEXAS			
CREEK SYSTEM IMPROVEMENTS			
CROSS-SECTIONS WINNWOOD PARK WEST			
GINN, INC. Consulting Engineers Dallas, Texas			
Designed - RCH	Drawn -	Date - NOV., 1988	Job No. - 369
Approved - HWG	Checked - RCH	Scale: H:1"=10'; V:1"=5'	Sheet 10 of 23

FINAL SURVEY
 SURVEYED BY
 NOTE BOOK NO.
 TEMPLATE AREAS CHECKED

ORIGINAL SURVEY
 SURVEYED BY
 NOTE BOOK NO.
 TEMPLATE AREAS CHECKED

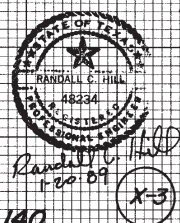
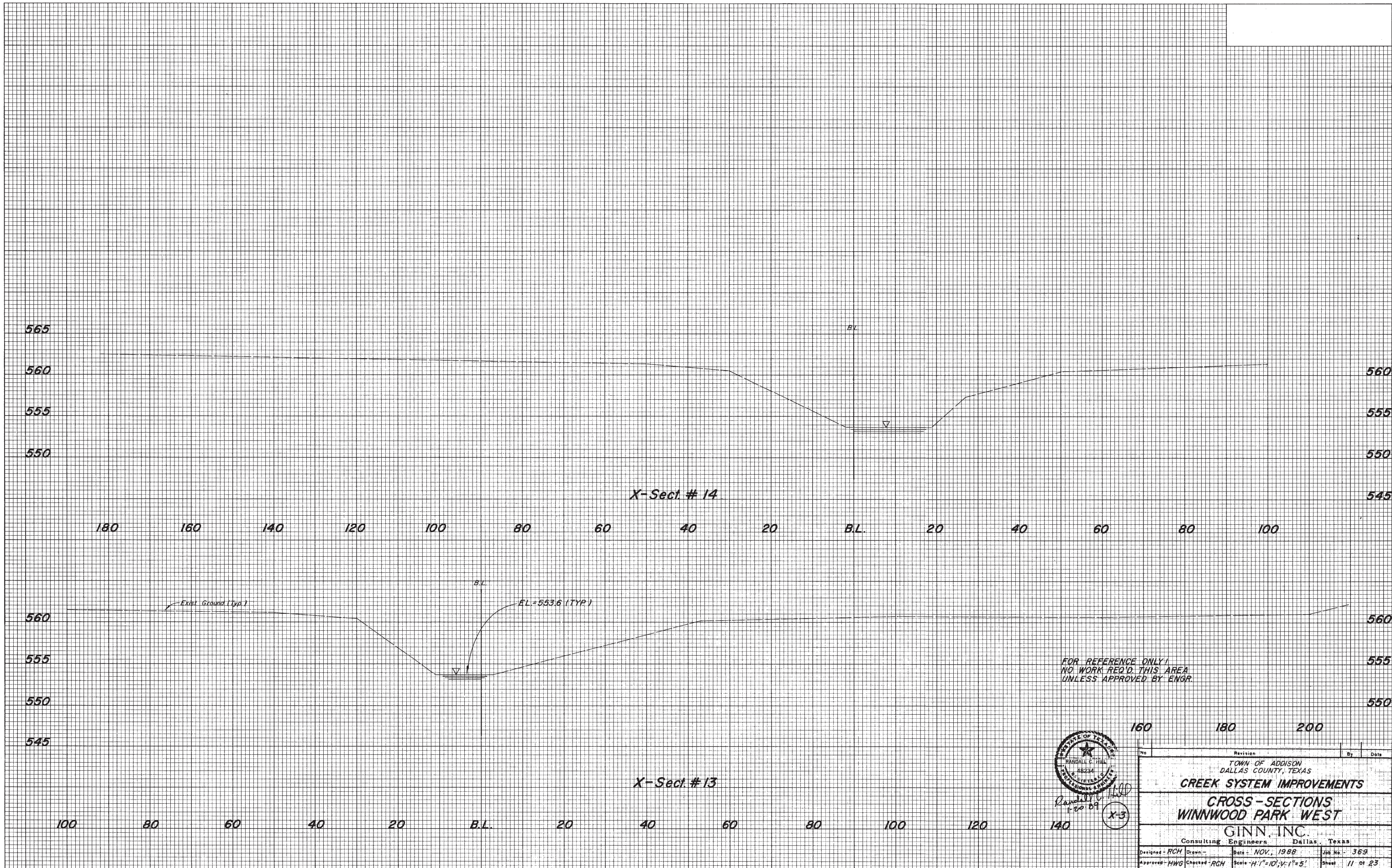

NO.	Revision	By	Date
	TOWN OF ADDISON DALLAS COUNTY, TEXAS		
CREEK SYSTEM IMPROVEMENTS			
CROSS-SECTIONS WINNWOOD PARK WEST			
GINN, INC. Consulting Engineers, Dallas, Texas			
Designed - RCH	Drawn -	Date - NOV, 1988	Job No. - 369
Approved - HWG	Checked - RCH	Scale - H:1"=10'; V:1"=5'	Sheet 11 of 23

BELTLINE ROAD

OAKS NORTH DRIVE

OAKS NORTH

NB LANE

Existing utility pole with new 3 phase pole mounted transformers

Do NOT cut pavement. Install conduit under pavement by means other than open cut.

Existing service conduit for existing single phase loads at Finance Center pad mounted transformer. Verify and locate exact routing before excavating for new pump station service.

New pump station service conduit - See electrical drawings for details.

Exist. utility pad mounted transformer

FINANCE CENTER PUMP STATION FOR DETAILS THIS AREA, SEE SHT. 14-17

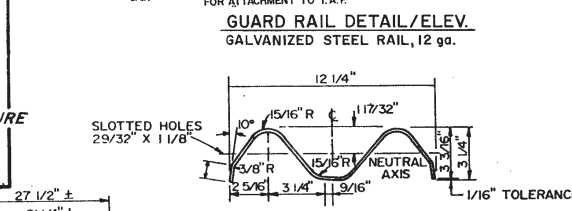
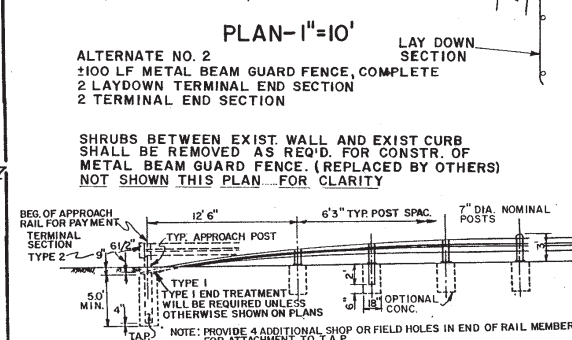
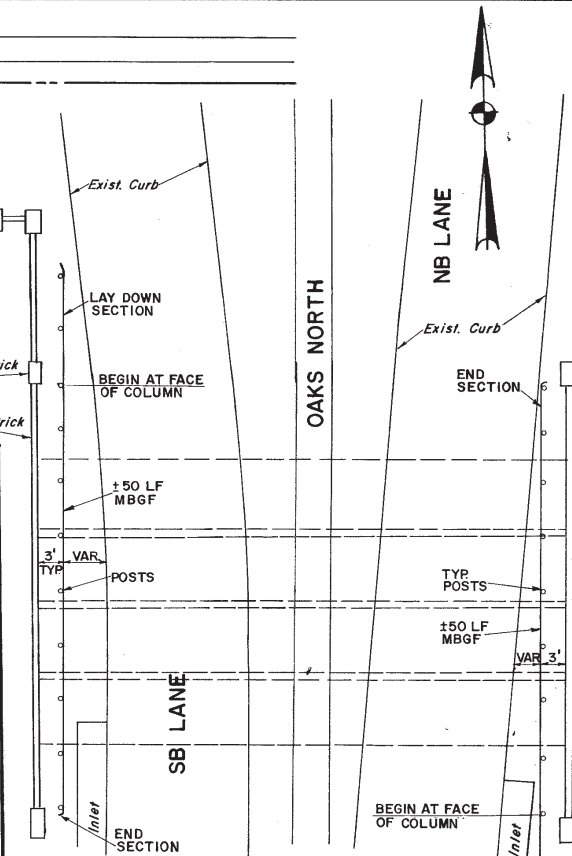

No.	Revision	By	Date

TOWN OF ADDISON
 DALLAS COUNTY, TEXAS

CREEK SYSTEM IMPROVEMENTS

FINANCE CENTER POND LAYOUT

GINN, INC.
 Consulting Engineers Dallas, Texas

Designed - RCH Drawn - DEM Date - OCT, 1988 Job No. - 369
 Approved - HWG Checked - RCH Scale - 1" = 20' Sheet 12 of 23



LAWRENCE McNALLY

GINN, INC. logo

369

Handwritten: Randall C. Hill 1-20-89

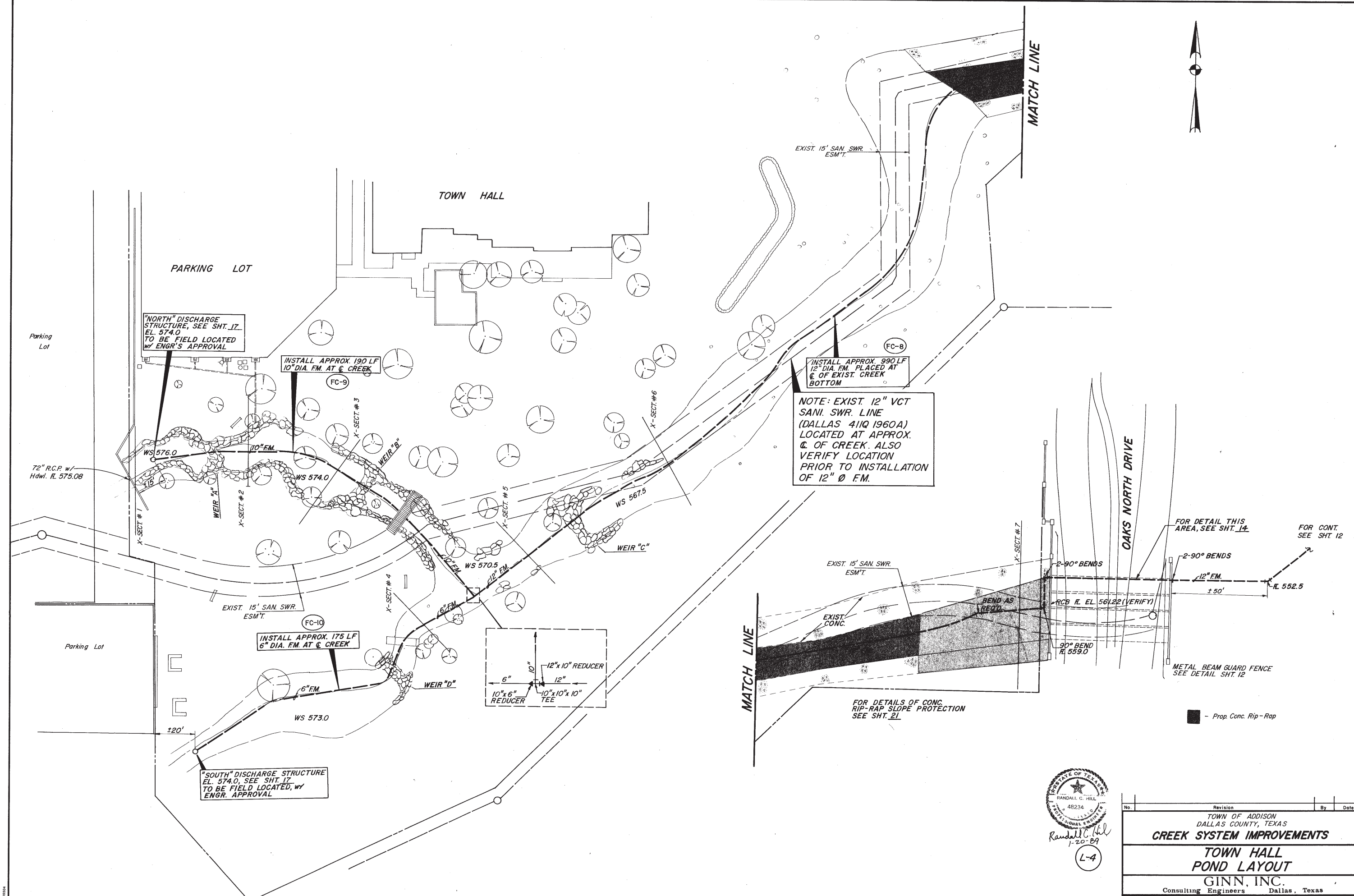

"NORTH" DISCHARGE STRUCTURE, SEE SHT. 17, EL. 574.0 TO BE FIELD LOCATED w/ ENGR'S APPROVAL

INSTALL APPROX. 190 LF 10" DIA. FM. AT & CREEK

INSTALL APPROX. 990 LF 12" DIA. FM. PLACED AT & OF EXIST. CREEK BOTTOM

NOTE: EXIST. 12" VCT SANI. SWR. LINE (DALLAS 411Q 1960A) LOCATED AT APPROX. & OF CREEK. ALSO VERIFY LOCATION PRIOR TO INSTALLATION OF 12" Ø FM.

INSTALL APPROX. 175 LF 6" DIA. FM. AT & CREEK

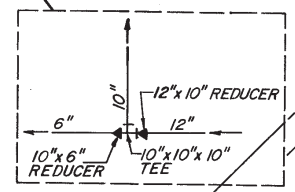

"SOUTH" DISCHARGE STRUCTURE EL. 574.0, SEE SHT. 17, TO BE FIELD LOCATED, w/ ENGR. APPROVAL

FOR DETAILS OF CONC. RIP-RAP SLOPE PROTECTION SEE SHT. 21

FOR DETAIL THIS AREA, SEE SHT. 14

FOR CONT. SEE SHT. 12

METAL BEAM GUARD FENCE SEE DETAIL SHT. 12

Prop. Conc. Rip-Rap

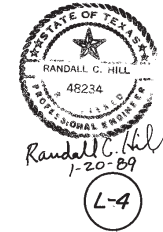

L-4

No.	Revision	By	Date
TOWN OF ADDISON DALLAS COUNTY, TEXAS			
CREEK SYSTEM IMPROVEMENTS			
TOWN HALL POND LAYOUT			
GINN, INC. Consulting Engineers Dallas, Texas			
Designed - RCH	Drawn - DEM	Date - OCT, 1988	Job No. - 369
Approved - HWG	Checked - RCH	Scale - 1" = 20'	Sheet 13 Of 23

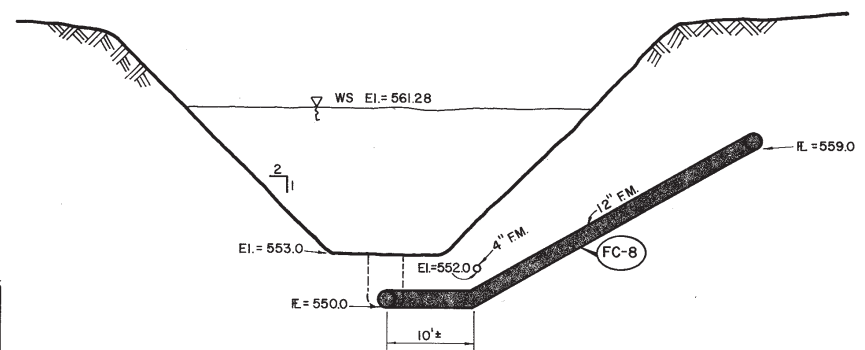
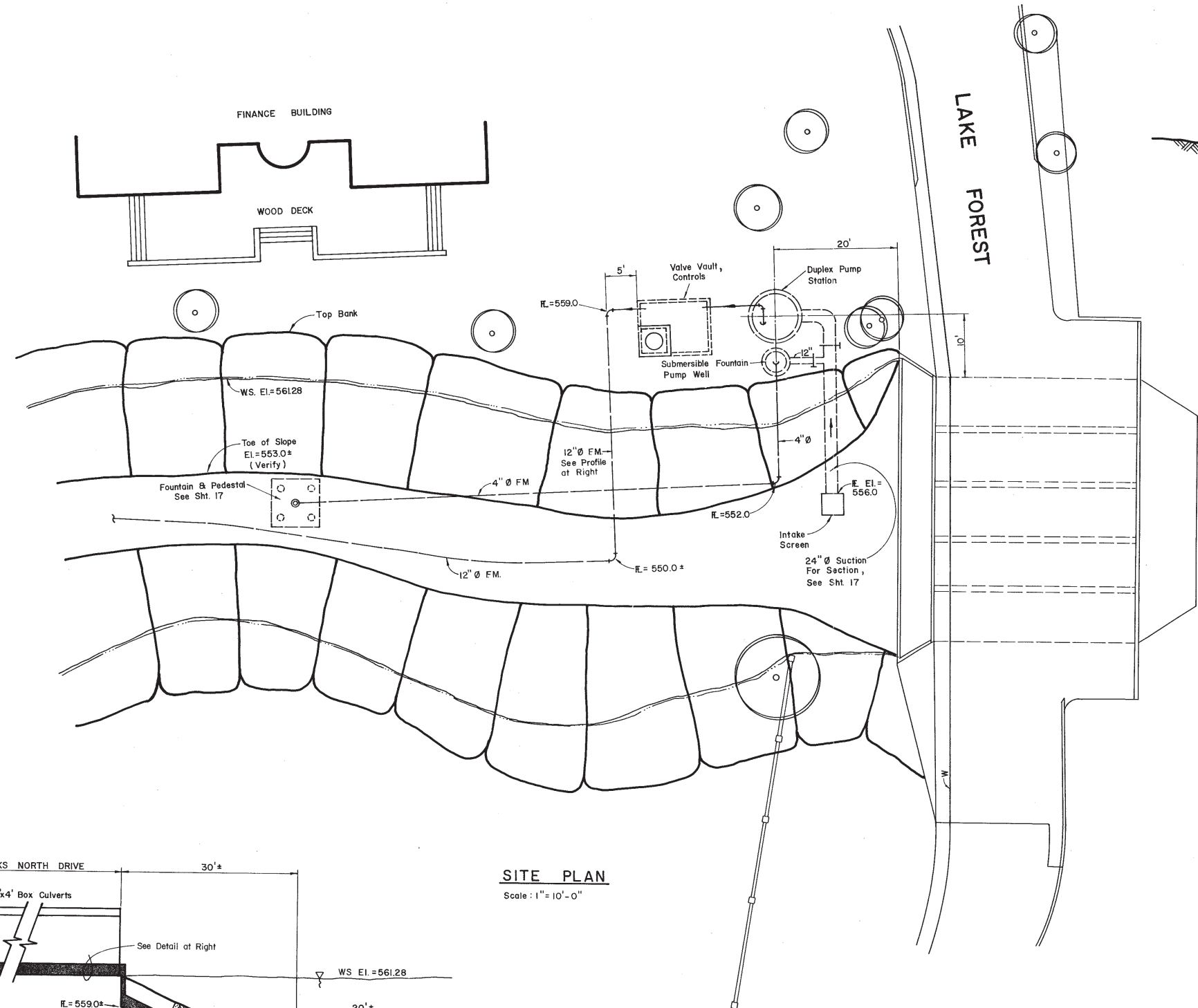

12" DISCHARGE PROFILE
Scale: 1" = 10' Horizontal, 1" = 5' Vertical

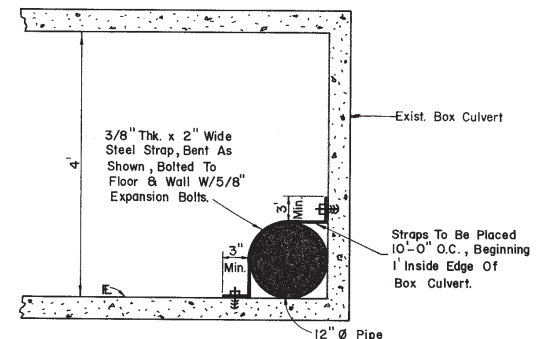

DETAIL PIPE LOCATION
No Scale

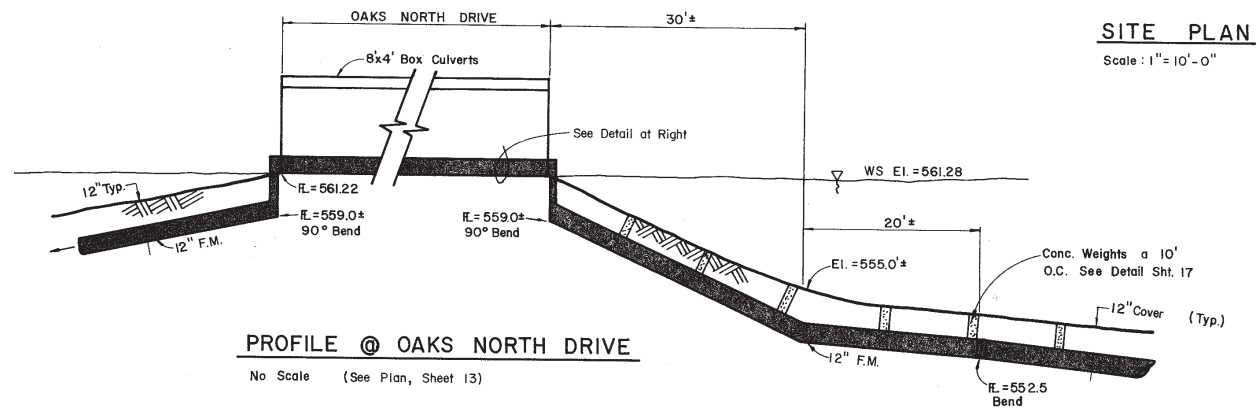

PROFILE @ OAKS NORTH DRIVE
No Scale (See Plan, Sheet 13)

SITE PLAN
Scale: 1" = 10'-0"

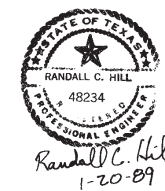

No.	Revision	By	Date
TOWN OF ADDISON DALLAS COUNTY, TEXAS CREEK SYSTEM IMPROVEMENTS FINANCE CENTER PUMP STATION SITE PLAN GINN, INC. Consulting Engineers Dallas, Texas			
Designed - RCH	Drawn - RLO	Date - OCT., 1988	Job No. - 369
Approved - HWG	Checked - RCH	Scale - 1" = 20'	Sheet 14 of 23

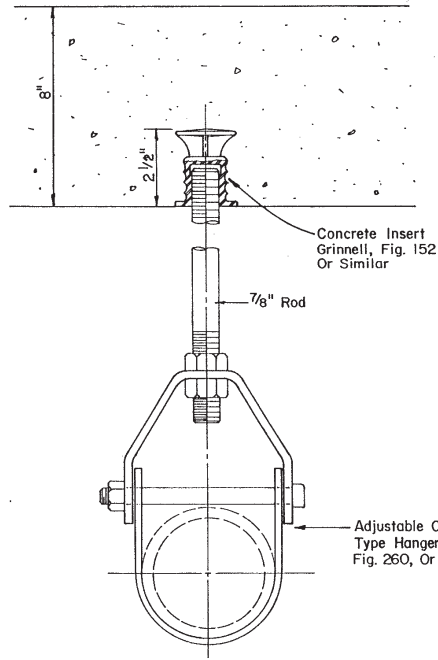

PIPE HANGER DETAIL
NO SCALE

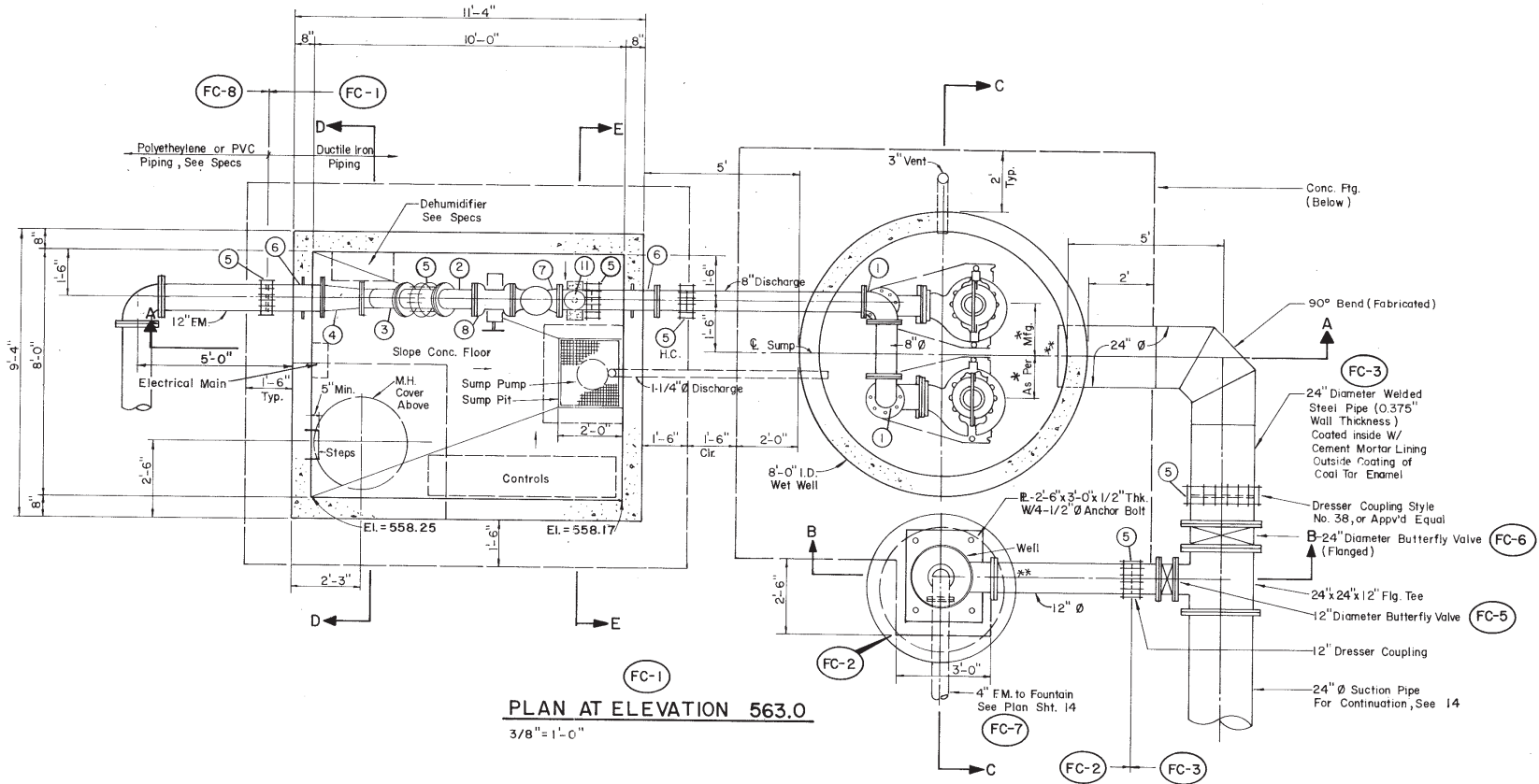

PLAN AT ELEVATION 563.0
3/8" = 1'-0"

* DENOTES DIMENSION TO BE SET BY PUMP SUPPLIER

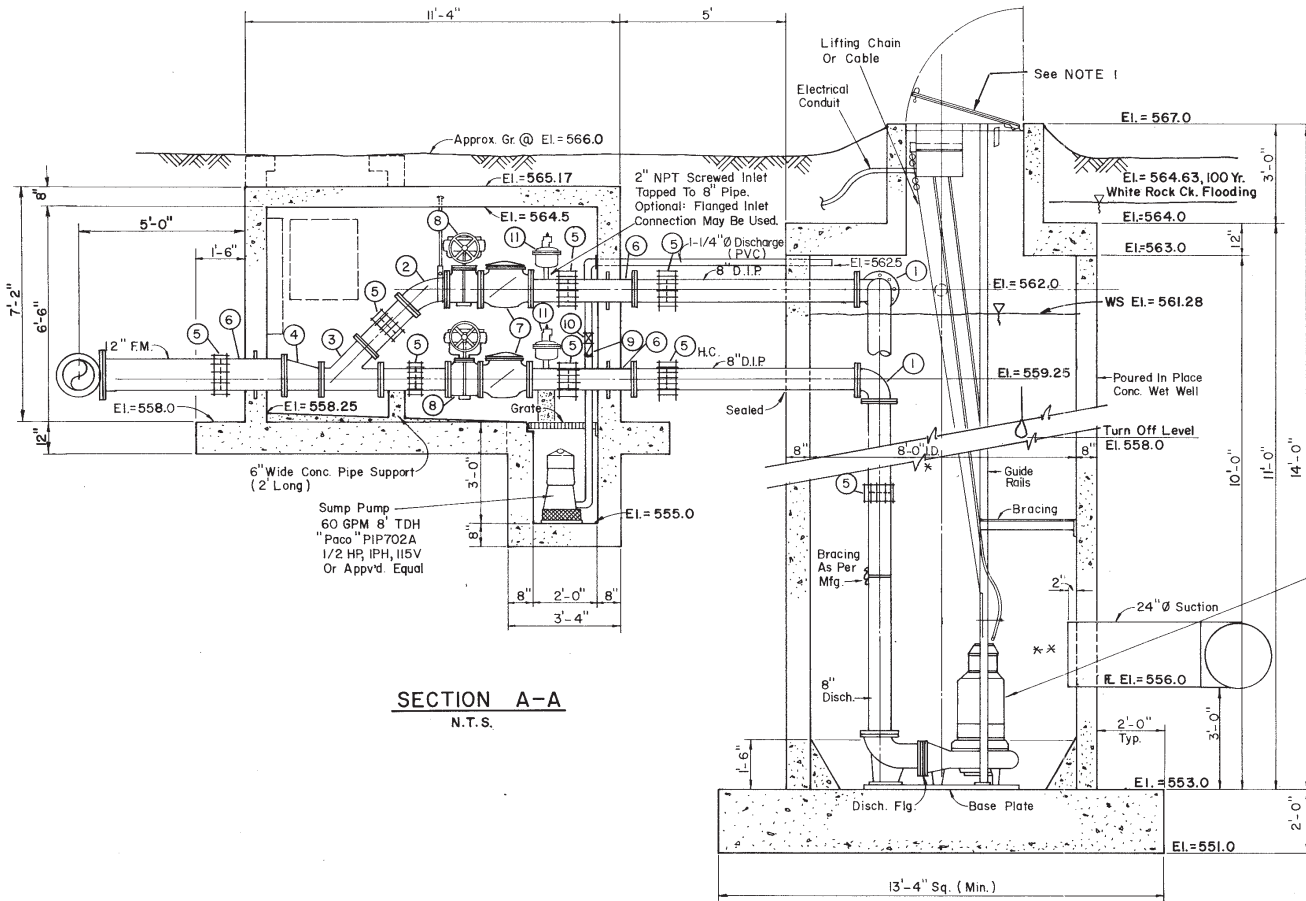

SECTION A-A
N.T.S.

- LEGEND**
- ① 90° Bend (Flanged)
 - ② 45° Bend (Flanged)
 - ③ 8" x 8" x 8" Lateral (Flanged)
 - ④ 12" x 8" Reducer (Flanged)
 - ⑤ "Dresser" Type Coupling (Size Indicated)
 - ⑥ Cast in Place Wall Pipe (Fig. 8 P.E.)
"Clow" F-1426, Or Approved Equal
 - ⑦ Check Valve (See Specs)
 - ⑧ Plug Valve (See Specs)
 - ⑨ 1-1/4" Check Valve
 - ⑩ 1-1/4" Gate Valve
 - ⑪ Air Valve
"Crispin" Model DL20, 2" Deep Well
Air Valve as Manufactured by
Multiplex Manufacturing Company, or
Approved Equal.

* PUMP SUPPLIER SHALL VERIFY THAT INSIDE DIAMETER IS ACCEPTABLE FOR HIS PUMPS.

** PUMP SUPPLIER SHALL VERIFY SIZE AND LOCATION OF SECTION LINE AND SHAPE OF SUMP. CHECK FOR DETRIMENTAL VELOCITIES AND VORTICES.

Duplex Pumps "Hydromatic" Submersibles
Model SBLX, 870 RPM, 1500 GPM @
40' TDH (Each) 20 HP, 3PH, 230 V
Or Approved Equal.

H.C. = Hornessed Coupling

NOTE 1:
Access door configuration, size, dimensions, installation, lifting chain or cable, guide rails, etc. are shown so as to be included in this construction. Actual details may have to be modified based upon pump station manufacturer's specific requirements. Contractor shall submit shop drawings to engineer for approval prior to any work being done. Optional flat slab top on pump station will be considered if all information is supplied for proper review.

NOTE: SEE SHEETS 6 & 7 FOR STEEL DESIGN



No.	Revision	By	Date
TOWN OF ADDISON DALLAS COUNTY, TEXAS CREEK SYSTEM IMPROVEMENTS			
FINANCE CENTER PUMP STATION PLAN AND SECTION GINN, INC. Consulting Engineers Dallas, Texas			
Designed - AGF	Drawn - CL	Date - DEC. 1988	Job No. - 369
Approved - HWG	Checked - RCH	Scale - AS NOTED	Sheet 15 of 23

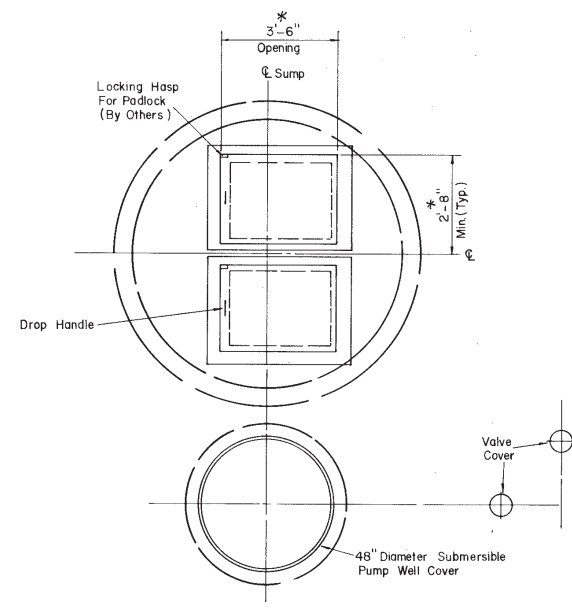

TOP VIEW
3/8" = 1'-0"
* DEPENDENT UPON PUMP MFG.

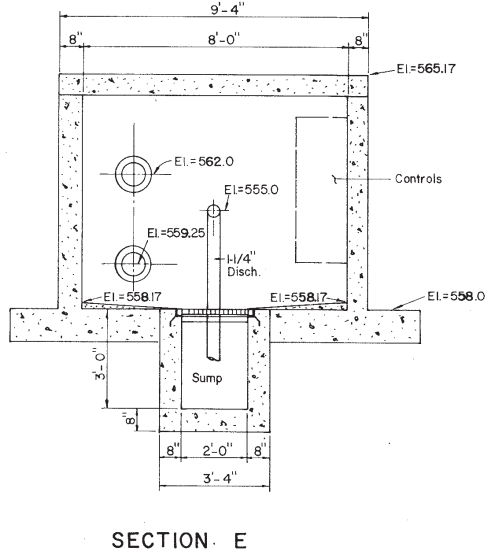
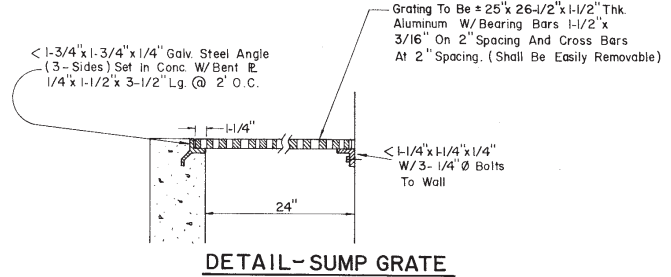
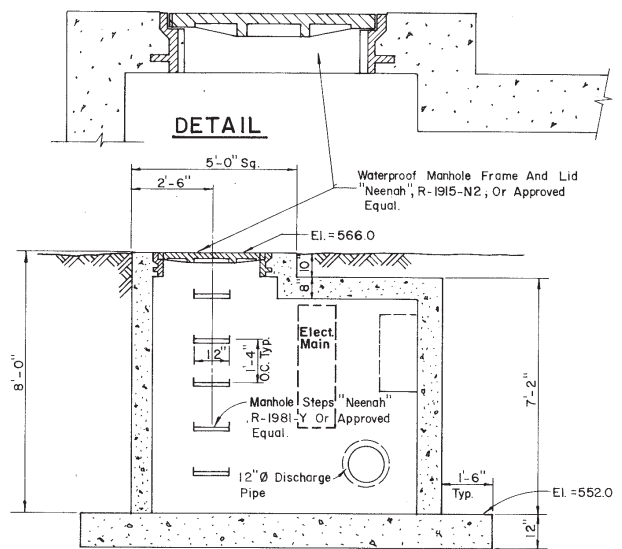
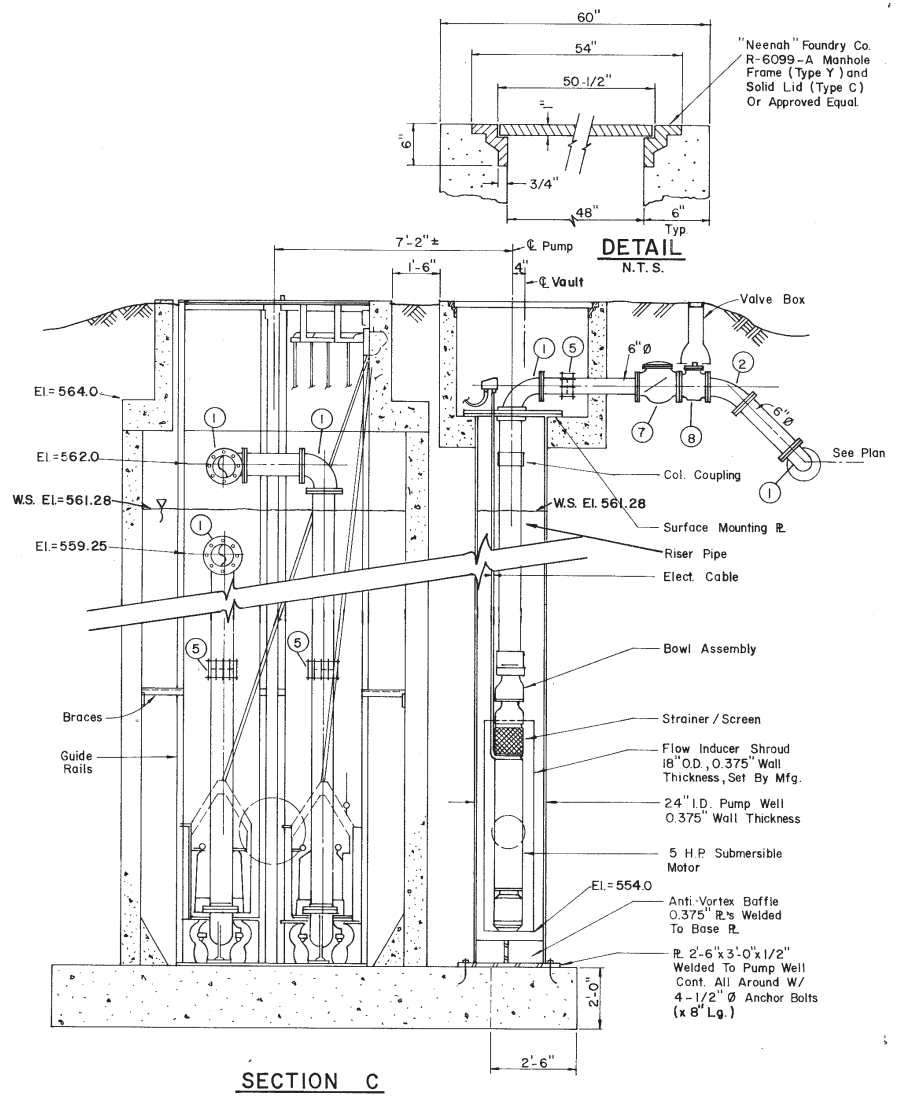
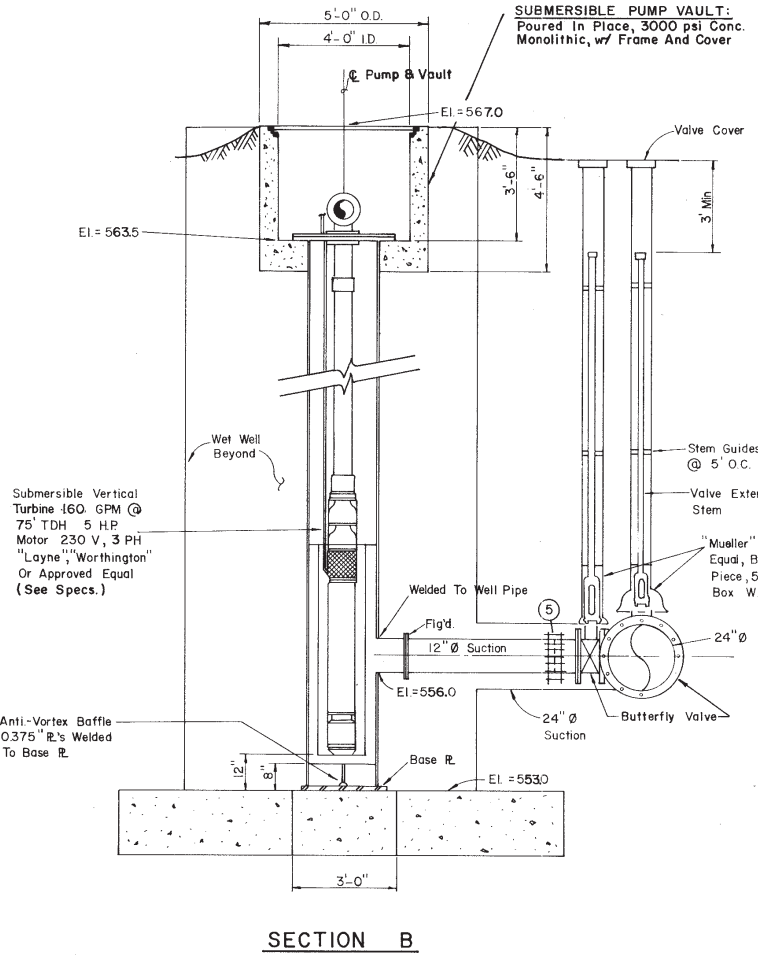

LEGEND

- ① 90° Bend (Flanged)
- ② 45° Bend (Flanged)
- ③ 8" x 8" x 8" Lateral (Flanged)
- ④ 12" x 8" Reducer (Flanged)
- ⑤ "Dresser" Type Coupling (Size Indicated)
- ⑥ Cast In Place Wall Pipe (Fig. & P.E.)
- "Clow" F-1426, Or Approved Equal
- ⑦ Check Valve (See Specs)
- ⑧ Plug Valve (See Specs)
- ⑨ 1-1/4" Check Valve
- ⑩ 1-1/4" Gate Valve

NOTE: SEE SHEETS 6 & 7 FOR STEEL DESIGN



Revision		By		Date	
TOWN OF ADDISON DALLAS COUNTY, TEXAS CREEK SYSTEM IMPROVEMENTS FINANCE CENTER PUMP STATION DETAILS GINN, INC. Consulting Engineers Dallas, Texas					
Designed - AGF	Drawn - CL	Date - DEC. 1988	Job No. - 369		
Approved - HWG	Checked - RCH	Scale - 3/8" = 1'-0"	Sheet 16 of 23		

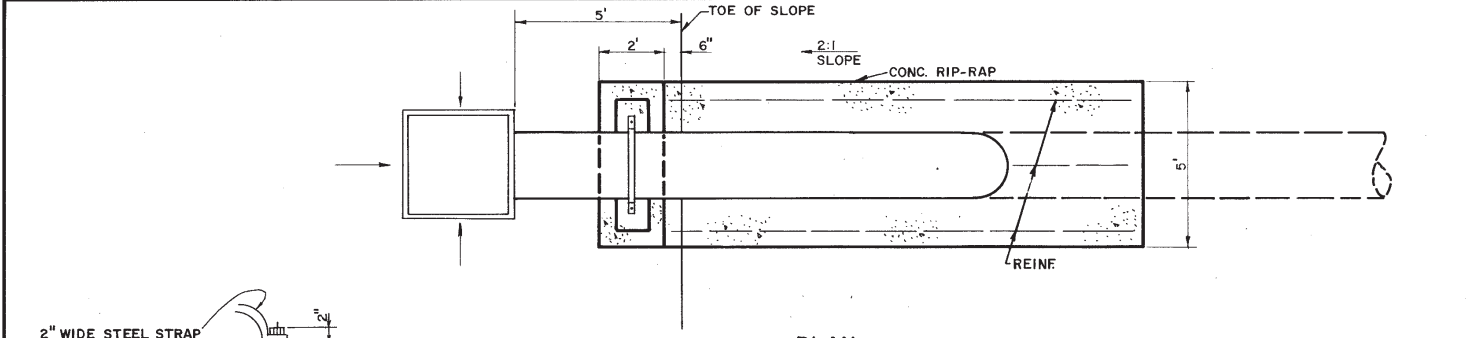

PLAN

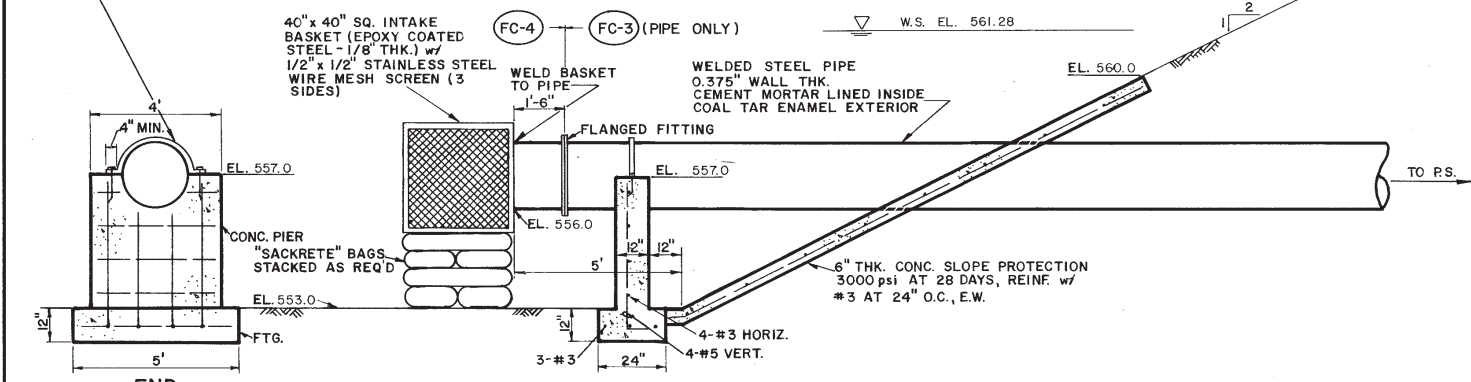
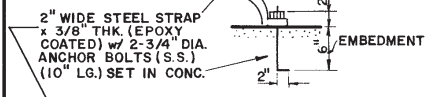

INTAKE STRUCTURE DETAILS (FC-4)

SCALE: 3/8" = 1'-0"

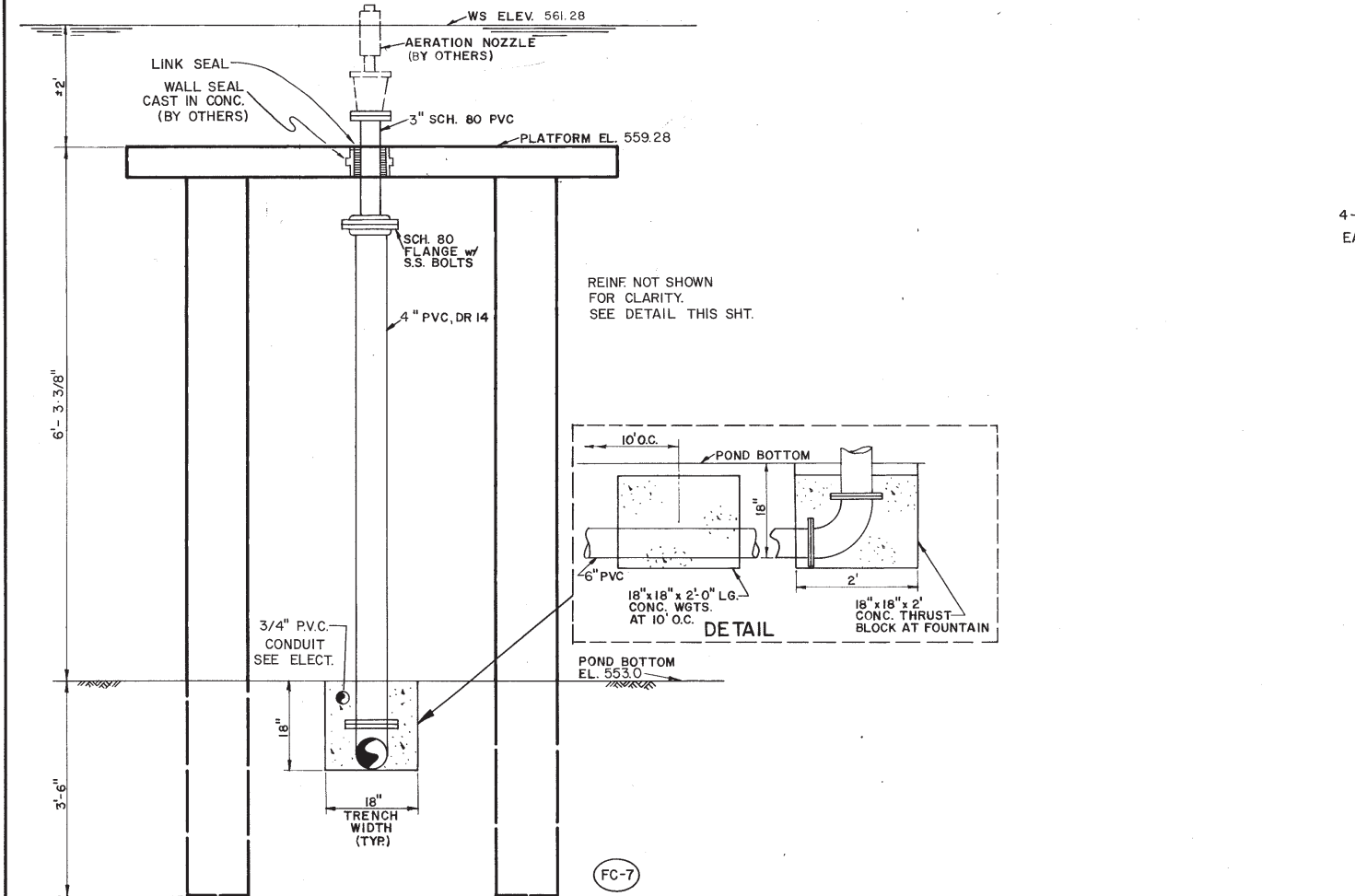

FOUNTAIN DETAIL (FC-7)

N.T.S.

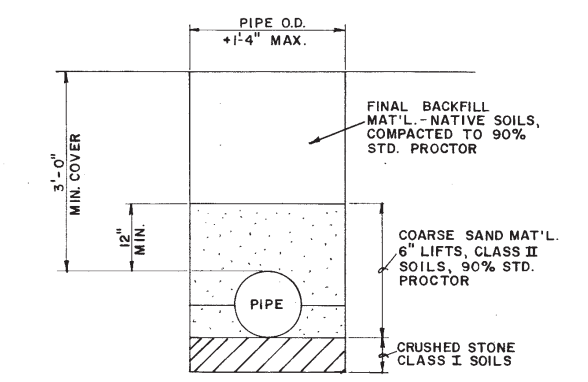

TYP. EMBEDMENT/BACKFILL DETAILS (FOR PIPE NOT SUBMERGED)

SCALE: 3/4" = 1'-0"

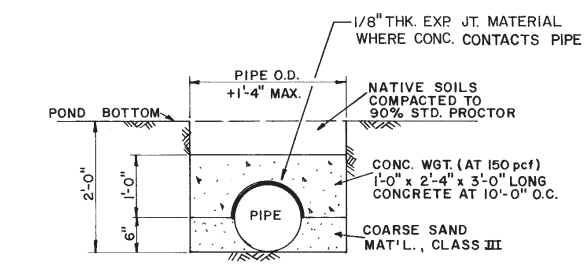

TYP. EMBEDMENT/BACKFILL DETAILS (FOR SUBMERGED PIPE)

SCALE: 3/4" = 1'-0"

DISCHARGE PIPE DETAILS

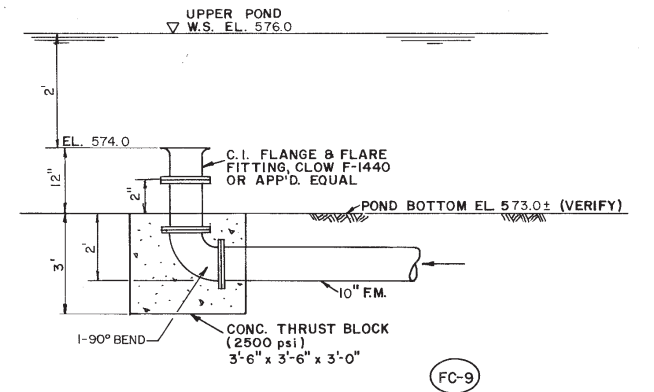

NORTH DISCHARGE STRUCTURE (FC-9)

N.T.S.

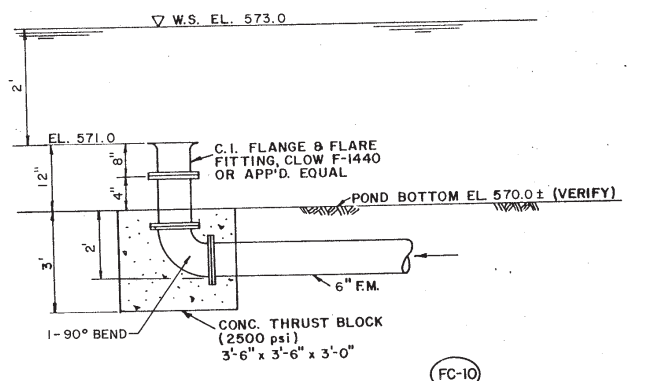

SOUTH DISCHARGE STRUCTURE (FC-10)

SCALE: N.T.S.

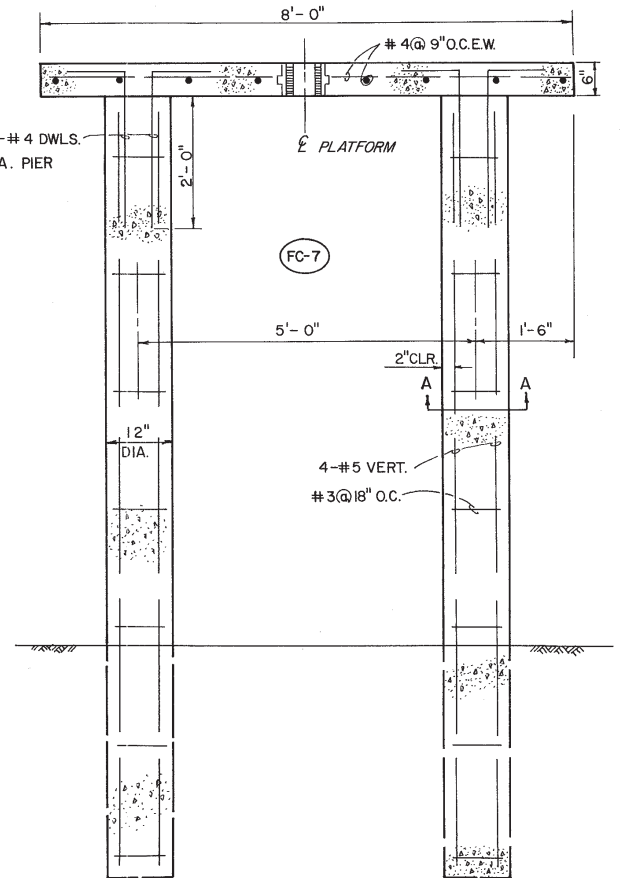

REINFORCEMENT DETAIL

N.T.S.

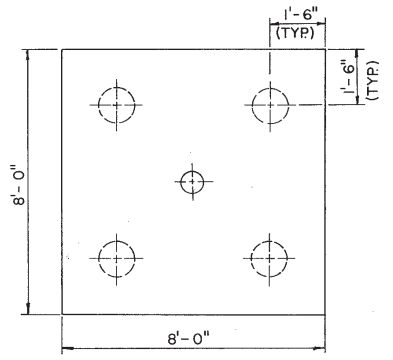

PLATFORM PLAN

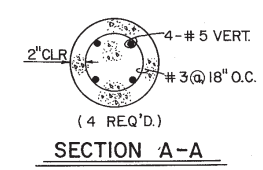

Randall C. Hill
1-20-89

No.	Revision	By	Date
TOWN OF ADDISON DALLAS COUNTY, TEXAS CREEK SYSTEM IMPROVEMENTS			
FINANCE CENTER/TOWN HALL MISCELLANEOUS DETAILS			
GINN, INC. Consulting Engineers Dallas, Texas			
Designed - AGF	Drawn - DEM	Date - DEC., 1988	Job No. - 369
Approved - HWG	Checked - RCH	Scale - AS NOTED	Sheet 17 of 23

FINAL SURVEY BY DATE
 SURVEYED BY
 PLOTTED BY
 NOTE BOOK NO. AREAS CHECKED

ORIGINAL SURVEY BY DATE
 SURVEYED BY
 PLOTTED BY
 NOTE BOOK NO. AREAS CHECKED

VOL = 109 C.Y.

565
560
555

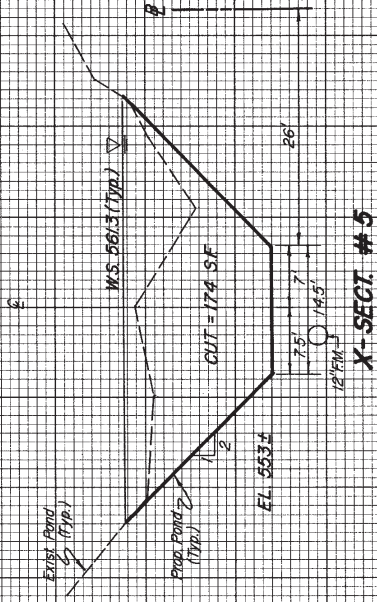

X-SECT. #5

VOL = 149 C.Y.

565
560
555

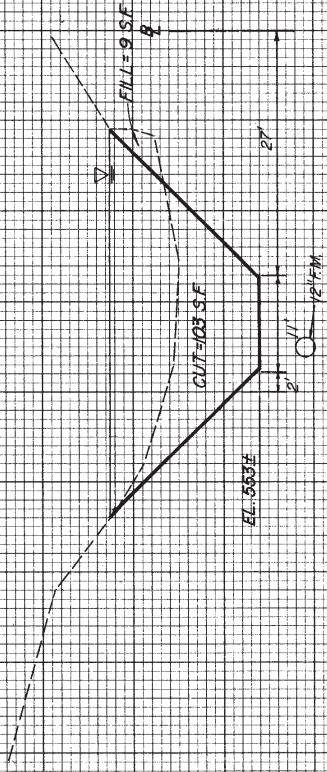

X-SECT. #4

VOL = 143 C.Y.

565
560
555

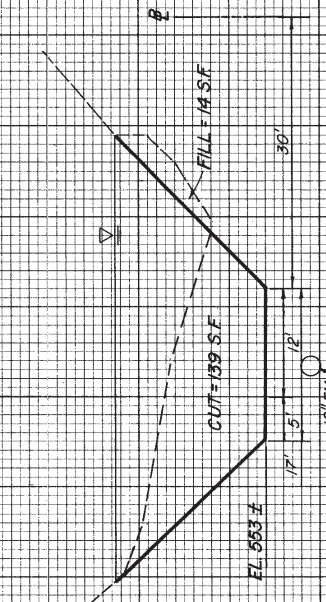

X-SECT. #3

VOL = 150 C.Y.

565
560
555

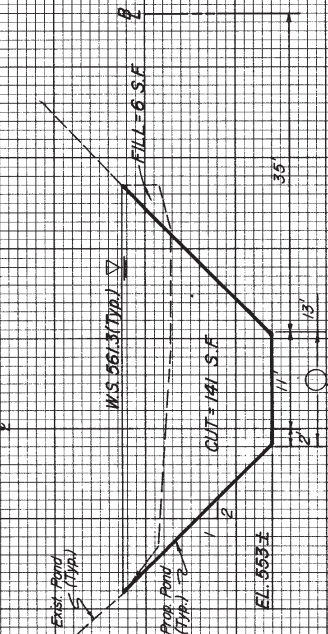

X-SECT. #2

VOL = 150 C.Y.

565
560
555

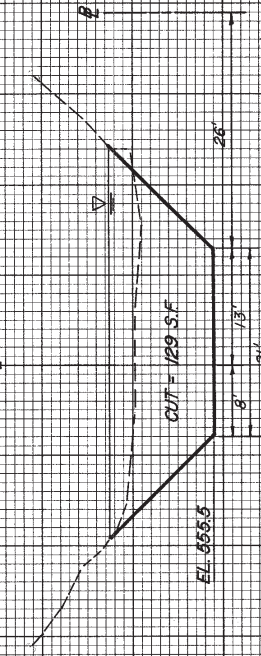

X-SECT. #1

VOL = 31 C.Y.



Randall S. Hix
 1-20-89
 X-4

TOWN OF ADDISON DALLAS COUNTY, TEXAS			
CREEK SYSTEM IMPROVEMENTS			
CROSS-SECTIONS FINANCE CENTER			
GINN, INC. Consulting Engineers Dallas, Texas			
Designed - RCH	Drawn - RLO	Date - OCT., 1988	Job No. - 369
Approved - HMG	Checked - RCH	Scale - H:1"=10', V:1"=5'	Sheet 18 of 23

FINAL SURVEY
 SURVEYED BY
 PLOTTED DATE
 NOTE BOOK NO.
 AREA CHECKED

ORIGINAL SURVEY
 SURVEYED BY
 PLOTTED DATE
 NOTE BOOK NO.
 AREA CHECKED

VOL = 47 CY

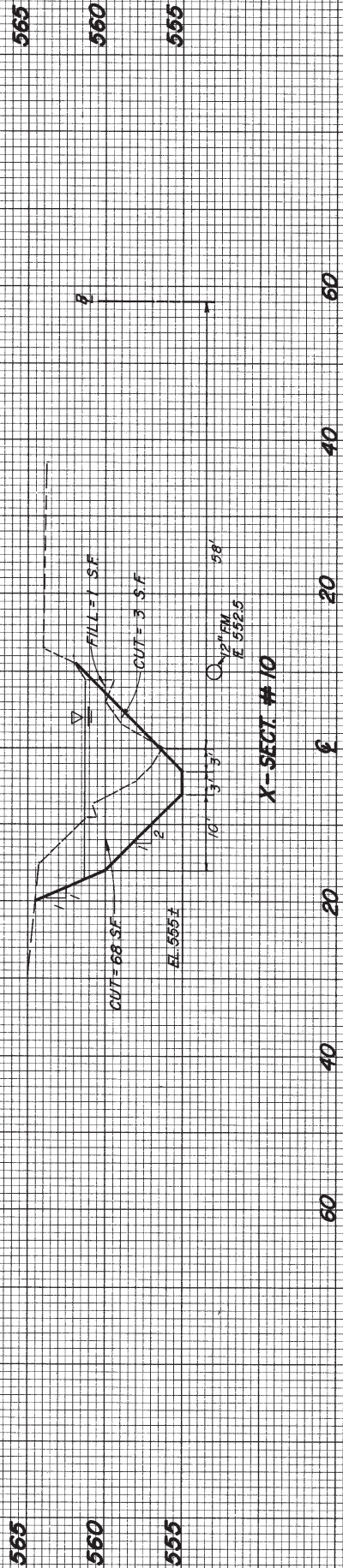

X-SECT. # 10

VOL = 860 CY

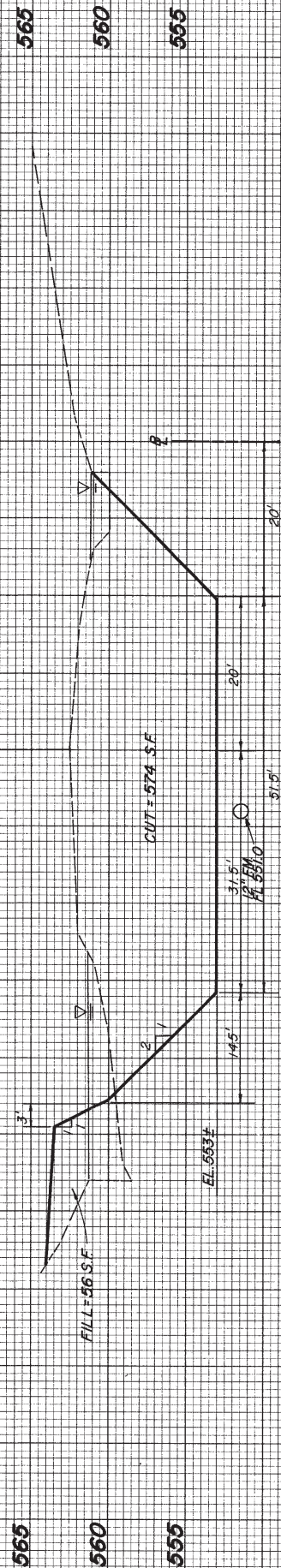

X-SECT. # 9

VOL = 530 CY

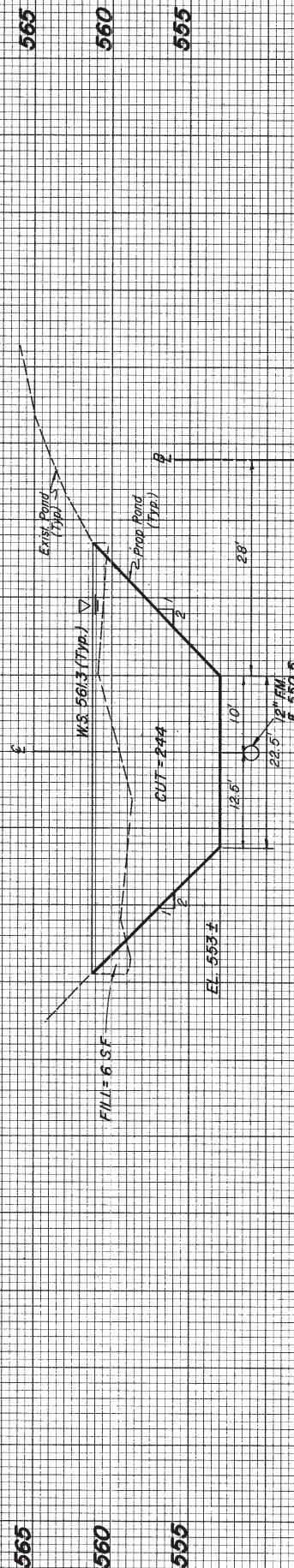

X-SECT. # 8

VOL = 235 CY

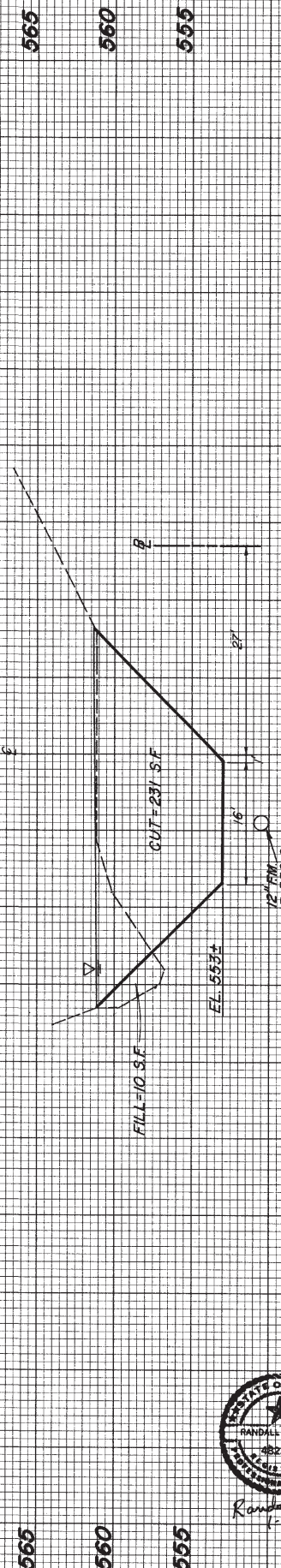

X-SECT. # 7

VOL = 224 CY

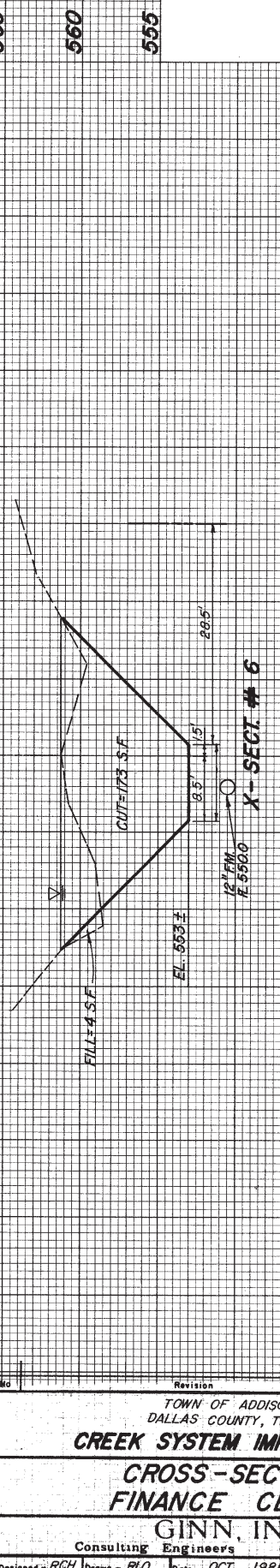

X-SECT. # 6

VOL = 109 CY

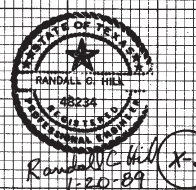

Revision		By		Date	
TOWN OF ADDISON DALLAS COUNTY, TEXAS					
CREEK SYSTEM IMPROVEMENTS					
CROSS-SECTIONS					
FINANCE CENTER					
GINN, INC.					
Consulting Engineers Dallas Texas					
Designed - RCH	Drawn - RLO	Date - OCT, 1988	Job No. - 389		
Approved - HWG	Checked - RCH	Scale - H:1"=10'; V:1"=5'	Sheet 19 of 23		

FINAL SURVEY PLOTTED
 NOTE BOOK NO. _____
 BY _____ DATE _____
 AREAS CHECKED _____

ORIGINAL SURVEY PLOTTED
 NOTE BOOK NO. _____
 BY _____ DATE _____
 AREAS CHECKED _____

575 570 565

30

20

10

0

10

20

30

X-SECT. #6

▽ H.S. 567.5

12" FM

575 570 565

0

▽ 570.5

X-SECT. #5

12" FM

575 570

0

6" FM

X-SECT. #4

575 570 565

0

▽ 574.0

X-SECT. #3

10" FM

580 575

0

X-SECT. #2

580 575 570

0

72" RCP

BETOND

X-SECT. #1

40

30

20

10

0

10

20

30

575 570 565

575 570 565

575 570

575 570 565

580 575

580 575



X-6

Revision		By	Date
TOWN OF ADDISON DALLAS COUNTY, TEXAS CREEK SYSTEM IMPROVEMENTS			
TOWN HALL CROSS-SECTIONS			
GINN, INC. Consulting Engineers Dallas, Texas			
Designed - RCH	Drawn - RLO	Date - OCT., 1988	Job No. - 369
Approved - HWG	Checked - RCH	Scale - H: 1" = 5', V: 1" = 5'	Sheet 20 of 23

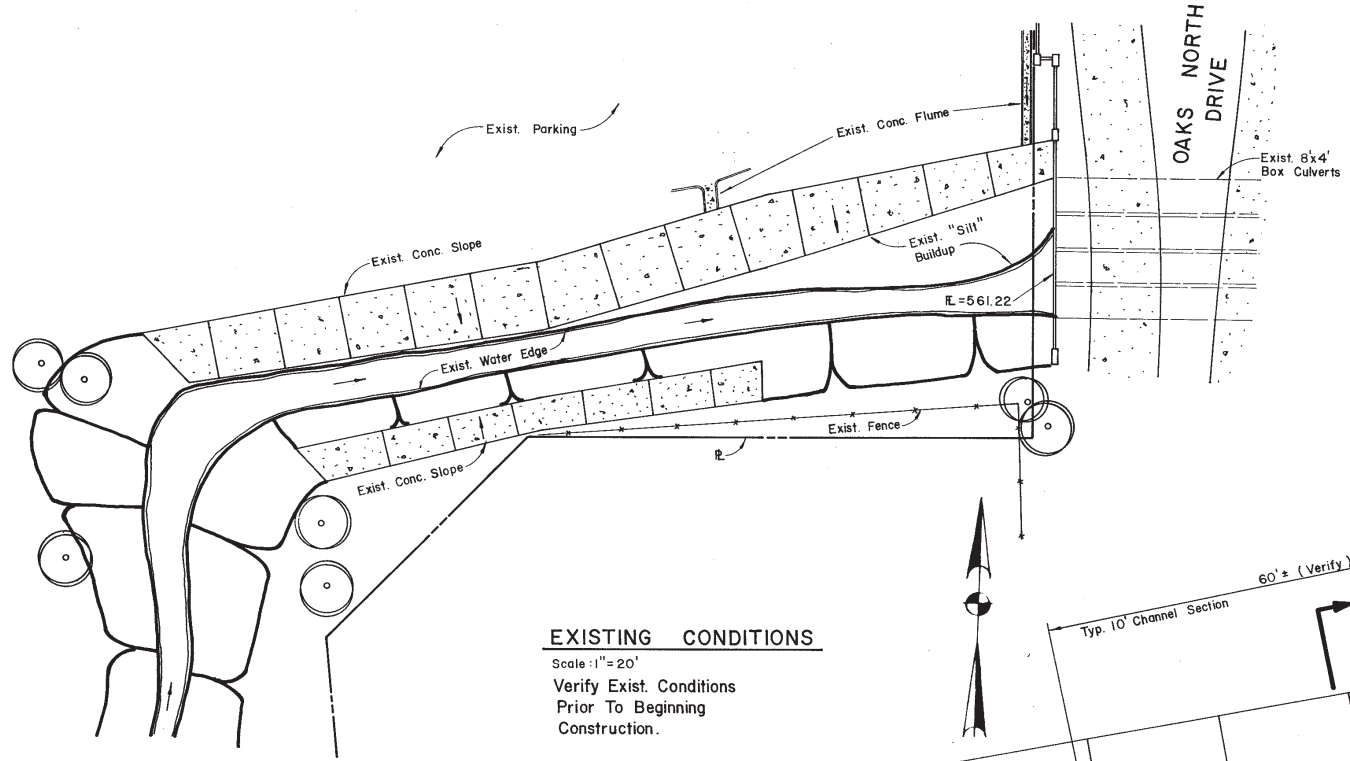

EXISTING CONDITIONS

Scale: 1" = 20'
 Verify Exist. Conditions
 Prior To Beginning
 Construction.

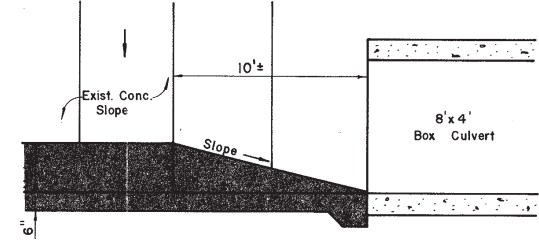

SECTION Y-Y
 No Scale

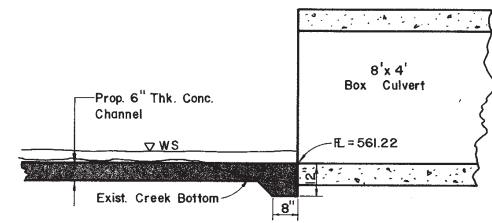

SECTION X-X
DETAIL AT BOX CULVERT
 Scale: 3/8" = 1'

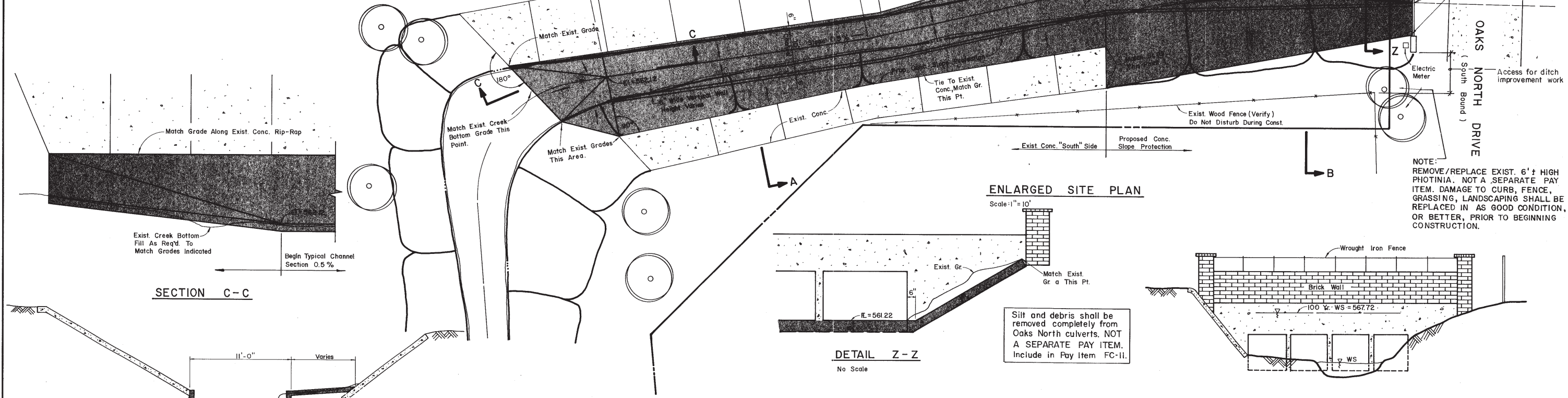

ENLARGED SITE PLAN

Scale: 1" = 10'

NOTE:
 REMOVE/REPLACE EXIST. 6'± HIGH
 PHOTINIA. NOT A SEPARATE PAY
 ITEM. DAMAGE TO CURB, FENCE,
 GRASSING, LANDSCAPING SHALL BE
 REPLACED IN AS GOOD CONDITION,
 OR BETTER, PRIOR TO BEGINNING
 CONSTRUCTION.

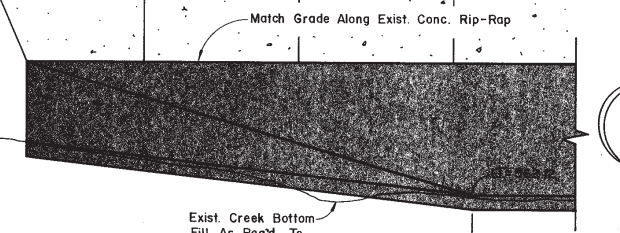

SECTION C-C

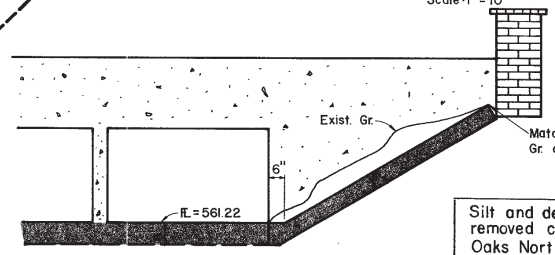

DETAIL Z-Z
 No Scale

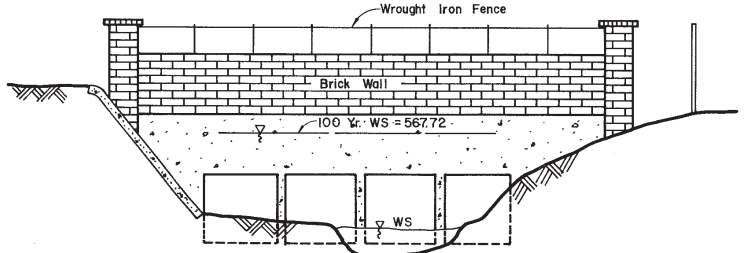

EXIST. ELEVATION @ OAKS NORTH DRIVE

(Looking East) (For Ref. Only)

No Scale

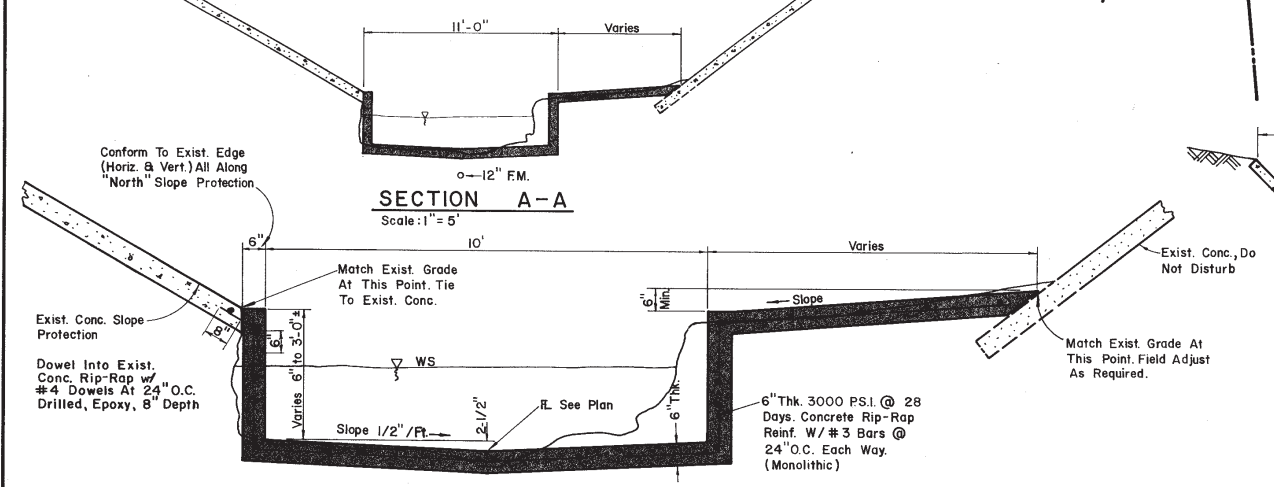

TYPICAL CHANNEL SECTION DETAIL
 Scale: 1/2" = 1'-0"

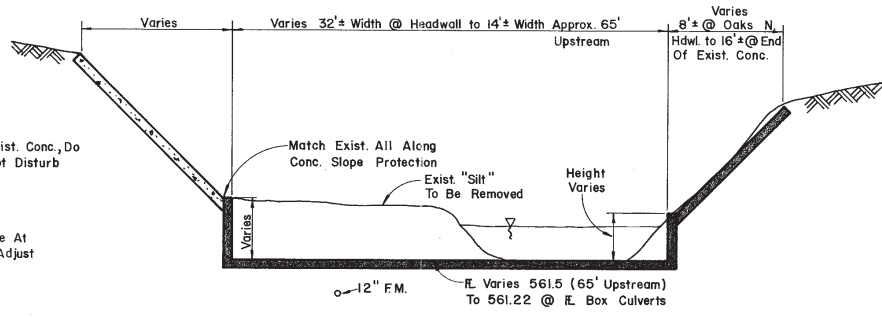

SECTION B-B
 No Scale

NOTE:

1. Provide 3/4" Exp. Joints a 40' Maximum Spacing. Use Redwood Material.
2. Provide Construction Joints Max. 10' Spacing Each Way In All Conc.



Randall C. Hill
 1-20-89
 (ALT-1)

ADD ALTERNATE NO. 1

Revision		By	Date
TOWN OF ADDISON DALLAS COUNTY, TEXAS CREEK SYSTEM IMPROVEMENTS TOWN HALL/OAKS NORTH DRIVE DITCH IMPROVEMENTS GINN, INC. Consulting Engineers Dallas, Texas			
Designed - AGF	Drawn - GL	Date - DEC. 1988	Job No. - 369
Approved - HWG	Checked - RCH	Scale - AS NOTED	Sheet 21 of 23

LEGEND

---	BELOW GRADE WIRING	☐	CURRENT TRANSFORMER
---	EXPOSED WIRING	⌂	BOLT INTO DRILLED EXPANSION SHEILD
---	HOME RUN-HOT, NEUTRAL, EGC SHOWN	⌂	SWITCH MOUNTED IN SURFACE WALL BOX
⊗	MOTOR-3HP SHOWN	⌂	DUPLEX RECP IN SURFACE WALL BOX
⊙	CEILING MOUNTED LIGHT FIXTURE	⌂	REMOTE DEVICE
⊙	WALL MOUNTED LIGHT FIXTURE	⌂	FUSE
⊙	FLUORESCENT FIXTURE	⌂	GROUND
⊙	POLE FLOODLIGHT (2 LUMINAIRES SHOWN)	⌂	GROUND FAULT RELAY & CT
⊙	EMERGENCY LIGHT FIXTURE	⌂	OVERLOADS
⊙	PILOT LIGHT, RED SHOWN	⌂	SAFETY SWITCH
⊙	MOTOR CONTROLLER (STARTER)	⌂	FUSED SAFETY SWITCH
⊙	NORMALLY CLOSED CONTACTS	⌂	SAFETY SWITCH WITH CIRCUIT BREAKER
⊙	NORMALLY OPEN CONTACTS	⌂	THERMOSTAT (AS USED ON PLANS)
⊙	LIMIT SWITCH-NORMALLY OPEN SHOWN	⌂	CONDUIT RISE
⊙	MOMENTARY OFF PUSHBUTTON	⌂	CONDUIT DROP
⊙	MOMENTARY ON PUSHBUTTON	⌂	CONTACTOR COIL
⊙	MAINTAINED PUSHBUTTON	⌂	CIRCUIT BREAKER
⊙	VOLTMETER	⌂	SURGE CAPACITOR
⊙	VOLTMETER WITH PHASE SELECTOR SWITCH	⌂	LIGHTING ARRESTER
⊙	AMMETER	⌂	JUNCTION BOX
⊙	AMMETER WITH PHASE SELECTOR SWITCH	⌂	TIMED CONTACTS
⊙	PRESSURE SWITCH	⌂	THERMOSTAT (AS USED ON DIAGRAMS)
⊙	SLOW SWITCH	⌂	LIQUID LEVEL SWITCH
⊙	DRAIN-OUT CONTACTS	⌂	TRANSFORMER
⊙	DUPLEX RECEPTACLE	⌂	PHASE OR DIAMETER
⊙	SPECIAL OUTLET	⌂	TELEPHONE OUTLET
⊙	FLUSH FLOOR RECEPTACLE	⌂	FLUSH FLOOR TELEPHONE OUTLET
⊙	T-FITTING	⌂	WEATHER/RAIN FITTING
⊙	TA-FITTING	⌂	FIELD TERMINAL
⊙	AFV ABOVE FINISHED FLOOR	⌂	MOTORIZED INTAKE VENT
⊙	LA LIGHTING ARRESTER	⌂	LIMIT SWITCH
⊙	EC EMPTY CONDUIT	⌂	FVNR FULL VOLTAGE NON-REVERSING
⊙	PB PUSHBUTTON	⌂	RVNR REDUCED VOLTAGE NON-REVERSING
⊙	HOA HAND-OFF-AUTOMATIC SELECTOR SWITCH	⌂	GFP GROUND FAULT PROTECTION
⊙	LTF LIQUID TIGHT FLEXIBLE CONDUIT	⌂	GFI GROUND FAULT CIRCUIT INTERRUPTER
⊙	MO REMOTE PILOT OPERATOR	⌂	CPT CONTROL POWER TRANSFORMER
⊙	HDB HOT DIP GALVANIZED	⌂	CU COPPER
⊙	E&C EQUIPMENT GROUNDING CONDUCTOR	⌂	EDCH ELECTRICALLY OPERATED ELECTRICALLY HELD
⊙	MCP MOTOR CIRCUIT PROTECTOR	⌂	EDMH ELECTRICALLY OPERATED MECHANICALLY HELD
⊙	BFP BLOWN FUSE PROTECTION	⌂	PC PHOTOCELL
⊙	ETM ELAPSED TIME METER	⌂	ICD INSTANT CLOSE, TIMED OPEN
⊙	MSP MAIN SERVICE PANEL	⌂	TCID TIMED CLOSE, INSTANT OPEN
⊙	HOW HARDWARE	⌂	NOC NORMALLY OPEN, TIMED CLOSE
⊙	HH HANDHOLE	⌂	CT CURRENT TRANSFORMER
⊙	STN STL STAINLESS STEEL	⌂	OLS OVERLOADS
⊙	CKT CIRCUIT	⌂	DES DRILLED EXPANSION SHEILD
⊙	BRKT BRACKET	⌂	ASC ALUMINUM SLOTTED CHANNEL
⊙	M&B MOTORIZED BACKDRIFT DAMPER	⌂	C&C CONCRETE
⊙	MV MERCURY VAPOR	⌂	PMR POWER
⊙	HPS HIGH PRESSURE SODIUM	⌂	DEP EXPANSION/DEFLECTION
⊙	S/S SAFETY SWITCH	⌂	MTD MOUNTED
⊙	8 SPST SWITCH	⌂	NO NORMALLY OPEN
⊙	8 SPST SWITCH	⌂	NC NORMALLY CLOSED
⊙	8 SPST SWITCH	⌂	C&D CONDUIT
⊙	8 SPST SWITCH	⌂	EF EXHAUST FAN
⊙	8 SWITCH WITH PILOT LIGHT	⌂	LLCO LOW LEVEL CUT OFF
⊙	8 MANUAL MOTOR STARTER	⌂	ALUM ALUMINUM
⊙	N/P NAME PLATE	⌂	S/N SOLID NEUTRAL
⊙	DC ON CENTER	⌂	XFMR TRANSFORMER
⊙	WP WEATHER PROOF	⌂	XMTR TRANSMITTER
⊙	RECP RECEPTACLE	⌂	XFER TRANSFER
⊙	RTD REMOTE TEMPERATURE DETECTOR	⌂	GND GROUND, GROUNDING, GROUNDED
⊙	EXOW EXOTHERMIC WELD	⌂	PVC POLYVINYL CHLORIDE
⊙	PCC PLASTIC COATED CONDUIT	⌂	SWGR SWITCHGEAR
⊙	ZRC ZINC RICH COMPOUND	⌂	RECR RECEIVER
⊙	CR CONTROL RELAY	⌂	FLA FULL LOAD AMPERAGE
⊙	BRB BEARING	⌂	MCC MOTOR CONTROL CENTER
⊙	PNL PANEL	⌂	HTG HEATING
⊙	SCH SCHEDULE	⌂	TYP TYPICAL
⊙	PMT PAD MOUNTED TRANSFORMER	⌂	FOR FEEDER
⊙	SIZE	⌂	MFR MANUFACTURER
⊙	SW SWITCH	⌂	TDR TIME-DELAY RELAY
⊙	RPD REMOTE PILOT DEVICE	⌂	SF SUPPLY FAN
⊙	RHD HIGH INTENSITY DISCHARGE	⌂	HTR HEATER
⊙	LPS LOW PRESSURE SODIUM	⌂	ITR INDICATE, TOTALIZE, RECORD
⊙	MM METAL HALIDE	⌂	DSL DOUBLE
⊙	LT LIGHT	⌂	PP PHASE PROTECTION
⊙	MLO MAIN LUSS ONLY	⌂	UH UNIT HEATER
⊙	MTR MOTOR	⌂	UB UNDERGROUND
⊙	N NEUTRAL		
⊙	MC MOTOR CONTROLLER		
⊙			
⊙			
⊙			
⊙			

CONDUIT AND CABLE SCHEDULE

CONDUIT TAG	WINNWOOD PUMP STATION	FINANCE CENTER PUMP STATION
C # 1	PMP MFR CABLES 3" C	PMP MFR CABLES 3" C
C # 1N	3 #6, #8G, 1" C 3 #10, #10N, #10G 4 #14 CONTROL	3 #6, #8G, 1" C 3 #10, #10N, #10G 4 #14 CONTROL
C # 2	PMP MFR CABLES, 3"C	PMP MFR CABLES, 3"C
C # 2N	3 #6, #8G, 1" C 4 #14 CONTROL	3 #6, #8G, 1" C 4 #14 CONTROL
C # 3	PMP MFR CABLES, 3"C	PMP MFR CABLES, 1-1/2 "C
C # 3N	3 #6, #8 G, 1" C 4 #14 CONTROL	3 #6, #8G, 1" C 4 #14 CONTROL
C # 4	2 #3, #3N, #6G, 1"C	2 #3, #3N, #6G, 1"C
C # 5	3 #10, #10 N, #10 G, 1"C 6 #14, #14 G (2 CONTROL WIRES TO EACH MC)	3 #10, #10 N, #10G, 1"C 6 #14, #14G (2 CONTROL WIRES TO EACH MC)
C # 6	3 #4/0, #3N, #4G 2"	3 #4/0, #3N, #4G 2"C
C # 7	3 #4/0, #3N, #4G 2"C	3 #4/0, #3N, #4G 2"C
C # 8	3 #4/0, #3N, 2"C	3 #4/0, #3N, 2"C
C # 9	8 #14, #14S 1"C	8 #14, #14G 1"C
C # 10	1 #14, #14N, #14G AND 2 #14, FOR CONTROL TO EACH TIME CLOCK	1 #14, #14N, #14G AND 2 #14, FOR CONTROL TO EACH TIME CLOCK

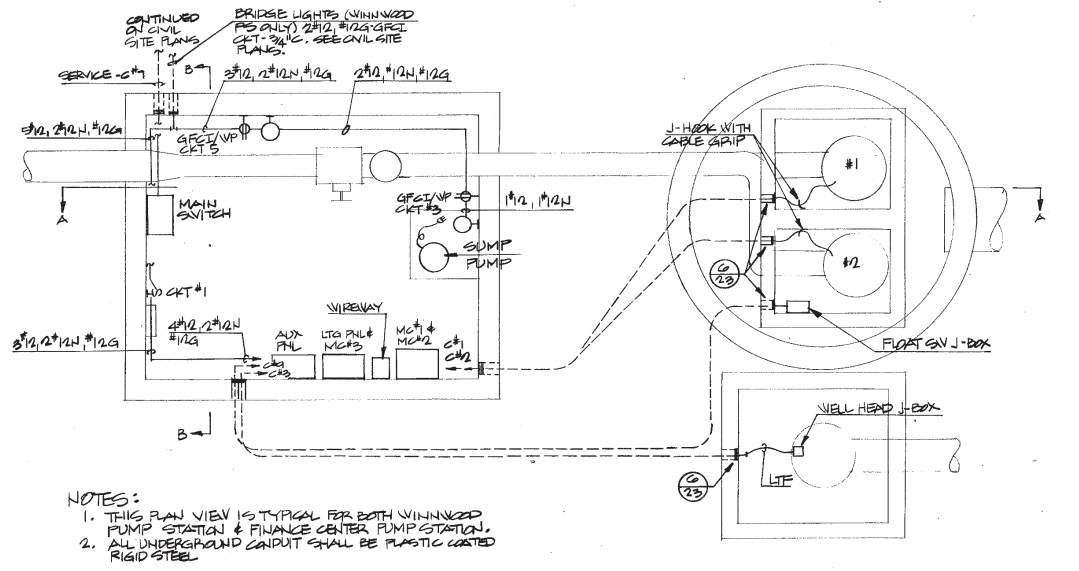

1 ELECTRICAL PLAN
SCALE 3/8" = 1'-0"

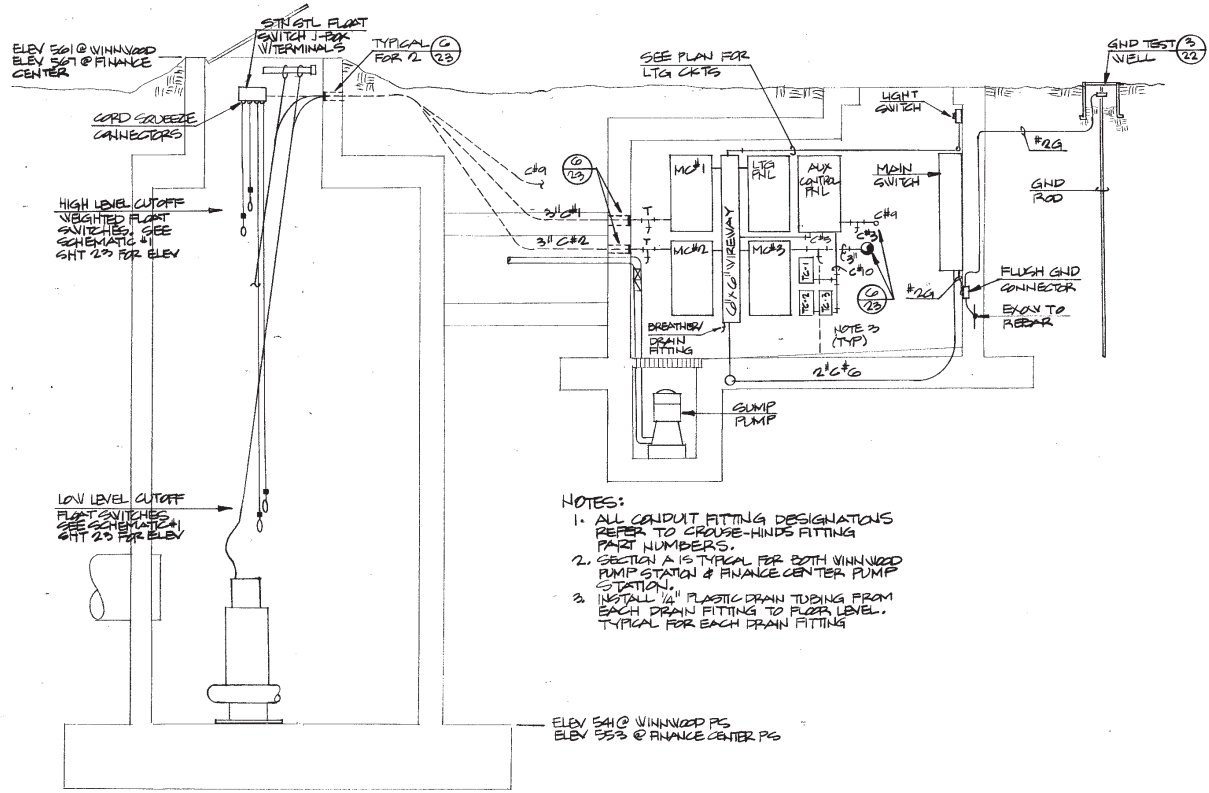

2 SECTION A
SCALE 3/8" = 1'-0"

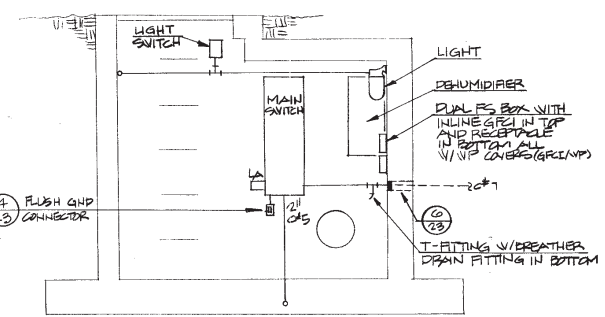

3 SECTION B
SCALE 3/8" = 1'-0"

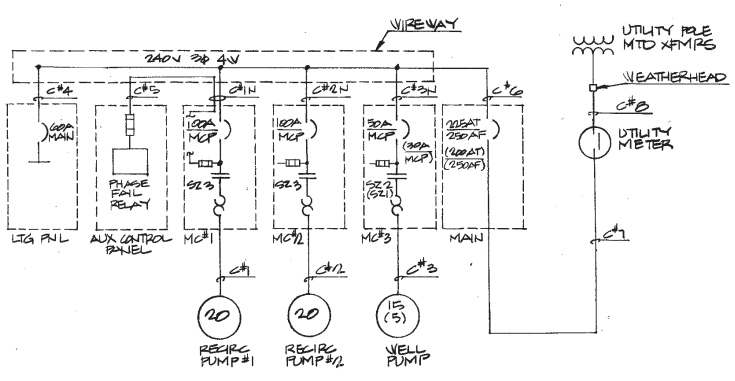

4 ONE LINE DIAGRAM

NOTES:

- ONE LINE DIAGRAM SHOWN IS TYPICAL FOR BOTH WINNWOOD PUMP STATION & FINANCE CENTER PUMP STATION. WELL PUMP IS 15HP AT WINNWOOD & 5HP AT FINANCE CENTER PUMP STATION. RATINGS FOR MCP'S & MAIN SW ARE SHOWN IN PARENTHESIS FOR FINANCE CENTER PUMP STATION. FURNISH & INSTALL ALL ELECTRICAL EQUIPMENT FOR BOTH PUMP STATIONS.

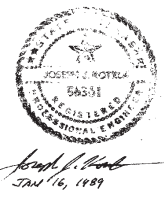

No.	Revision	By	Date
<p>TOWN OF ADDISON DALLAS COUNTY, TEXAS CREEK SYSTEM IMPROVEMENTS</p> <p>ELECTRICAL TYPICAL PUMP STATION</p> <p>GINN, INC. Consulting Engineers Dallas, Texas</p>			
Designed - JK	Drawn - JW	Date - DEC, 1988	Job No. - 369
Approved - JK	Checked - JK	Scale - 3/8" = 1'-0"	Sheet 22 OF 23

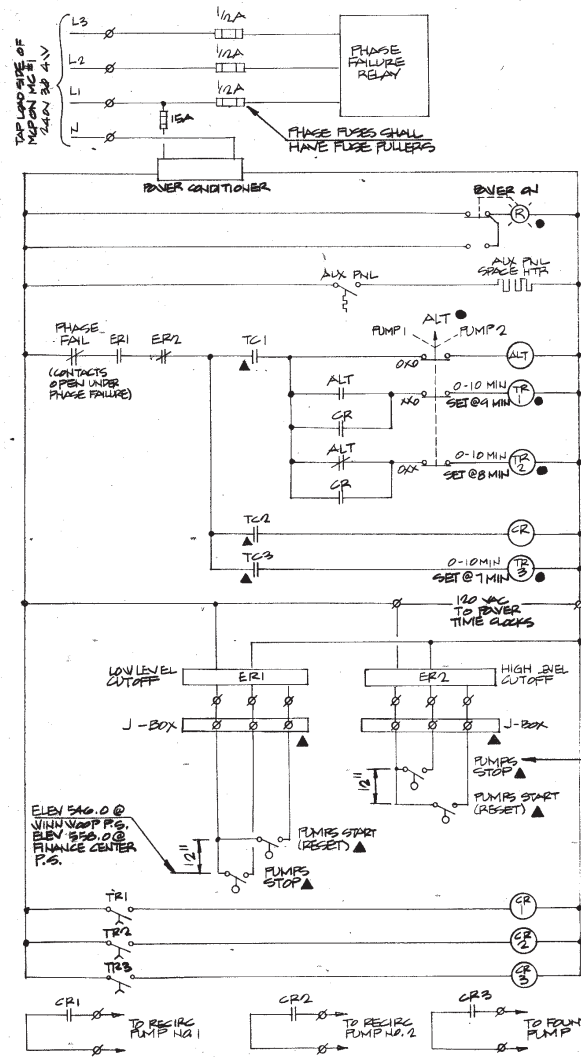

NOTES:
1. SCHEMATIC IS TYPICAL FOR TWO AUXILIARY CONTROL PANELS, ONE AT WINWOOD PUMP STATION AND ONE AT THE FINANCE CENTER PUMP STATION.

1 AUXILIARY CONTROL PANEL SCHEMATIC

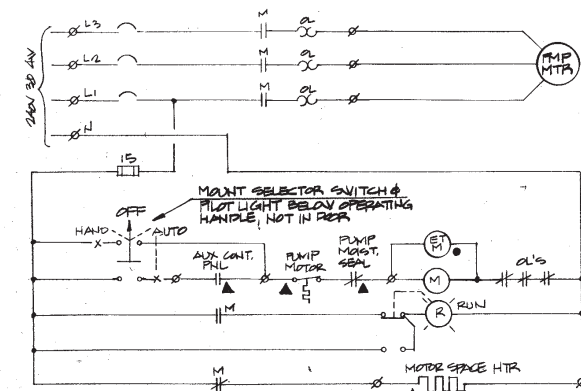

2 PUMP STARTER CONTROL SCHEMATIC

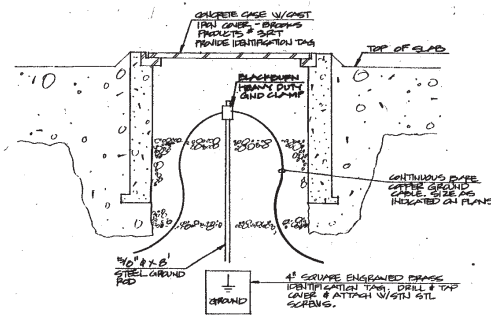

3 GROUND ROD & WELL
NO SCALE

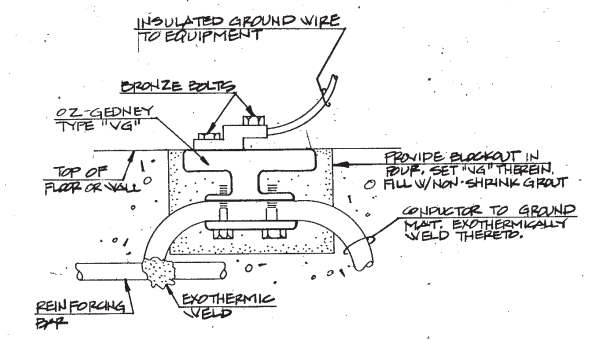

4 IN-SLAB GROUNDING CONNECTOR
NO SCALE

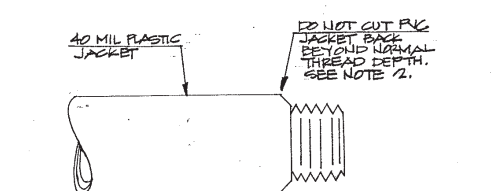

5 FIELD THREADING OF PVC
COATED METALLIC CONDUIT

NOTES:
1. COAT FIELD CUT THREADS W/ THREAD COMPOUND
2. USE SPECIAL CONDUIT DIES THAT HAVE OVER-
SIZED REAR OPENING THAT WILL ALLOW BODY
OF DIE TO SLIP OVER 40 MIL PVC COATING.
3. FOLLOW MANUFACTURER'S INSTALLATION
DIRECTIONS.

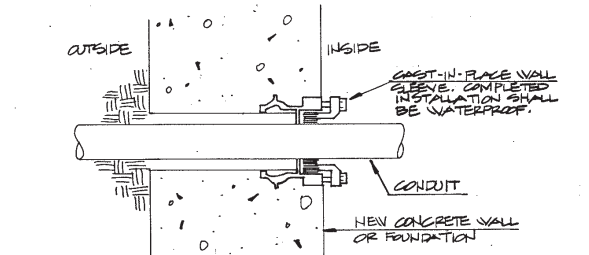

6 CONDUIT WALL PENETRATION
NO SCALE

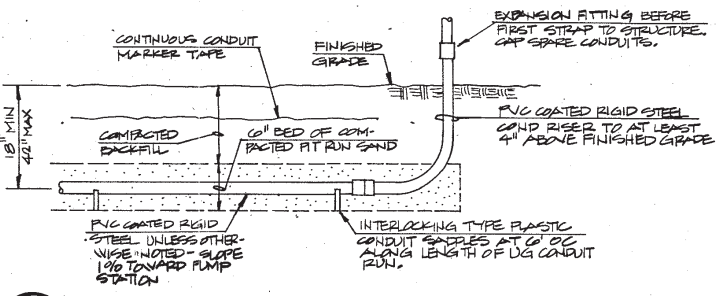

7 UNDERGROUND CONDUIT RUN
NO SCALE

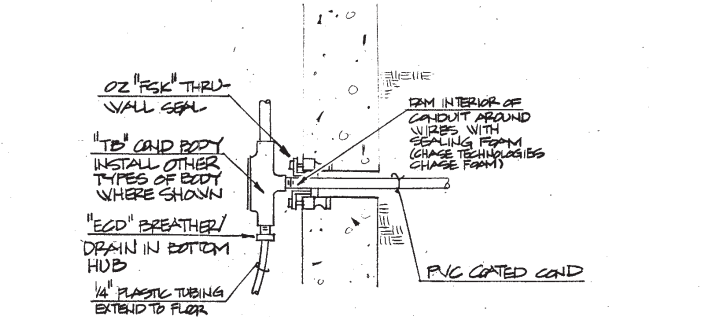

8 BELOW GRADE WALL PENETRATION
NO SCALE

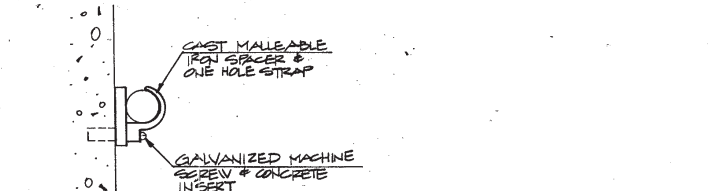

9 EXPOSED CONDUIT INSTAL-
LATION - CEILING OR WALL
NO SCALE

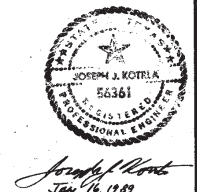

Joseph A. Kotler
Jan 14, 1989

No.	Revision	By	Date
TOWN OF ADDISON DALLAS COUNTY, TEXAS CREEK SYSTEM IMPROVEMENTS			
ELECTRICAL SCHEMATICS & DETAILS			
GINN, INC. Consulting Engineers Dallas, Texas			
Designed - JK	Drawn - JW	Date - DEC, 1988	Job No. - 369
Approved - JK	Checked - JK	Scale - NONE	Sheet 23 Of 23