

1997 Spring Valley / Greenhill School Signal

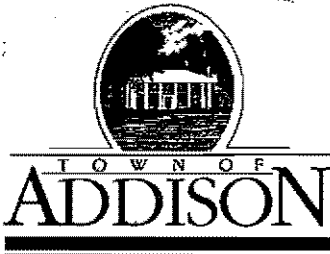

TOWN OF ADDISON
P.O. BOX 144
ADDISON, TEXAS 75001
TELEPHONE: (214) 233-1331

STATEMENT
NO. **10607**

STATEMENT DATE
06/27/97

Mr. Kenneth Piel
Greenhill School
14255 Midway R.
Addison, TX 75244-3698

MAIL REMITTANCE TO
TOWN OF ADDISON
P.O. BOX 144
ADDISON, TEXAS 75001

Fold along this line

DATE	DESCRIPTION	AMOUNT
06/27/97	Final payment Greenhill School's cost of traffic signal project on Greenhill School Road and Spring Valley.  TOWN OF ADDISON	\$32,379.25

Fold along this line

PREPARED BY: **A. Hernandez**
ACCOUNT CHARGED: **41-000-54270-63300**

TOTAL AMOUNT DUE **\$32,379.25**

TERMS: Due upon receipt of Statement

TO INSURE PROPER CREDIT - RETURN REMITTANCE COPY WITH PAYMENT.

DEPARTMENT COPY

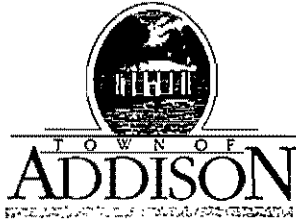

PUBLIC WORKS DEPARTMENT

Post Office Box 144 Addison, Texas 75001

(972) 450-2871

16801 Westgrove

June 26, 1997

Kenneth A. Piel
Greenhill School
14255 Midway Road
Addison, Texas 75244-3698

Re: Spring Valley/Greenhill School Traffic Signal

Dear Mr. Ken:

Attached is an invoice for \$32,379.25 which represents Greenhill School's final payment of the cost of the traffic signal project on Spring Valley and Greenhill School Road. The final cost of the signal installation was \$83,839. Greenhill School's portion of this (75%) comes to a total of \$62,879.25 minus the \$30,500 paid in May.

We enjoyed working with you on this project, and hope you are as satisfied as we are with the completed installation.

Sincerely,

John Baumgartner
Director of Public Works

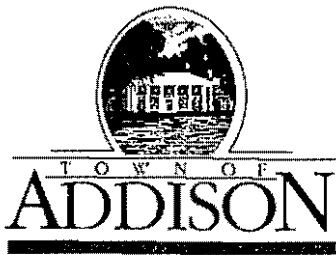

TOWN OF ADDISON
 P.O. BOX 144
 ADDISON, TEXAS 75001
 TELEPHONE: (214) 233-1331

STATEMENT
 NO. 10607

STATEMENT DATE
06/27/97

Mr. Kenneth Piel
 Greenhill School
 14255 Midway R.
 Addison, TX 75244-3698

MAIL REMITTANCE TO:
TOWN OF ADDISON P.O. BOX 144 ADDISON, TEXAS 75001

← Fold along this line

DATE	DESCRIPTION	AMOUNT
06/27/97	Final payment Greenhill School's cost of traffic signal project on Greenhill School Road and Spring Valley.	\$32,379.25

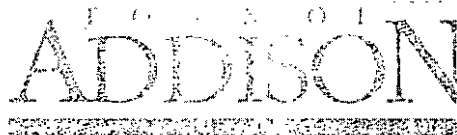

← Fold along this line

PREPARED BY: A. Hernandez *RH*
 ACCOUNT CHARGED: 41-000-54270-63300

TOTAL AMOUNT DUE	\$32,379.25
-------------------------	--------------------

TERMS: Due upon receipt of Statement

TO INSURE PROPER CREDIT RETURN

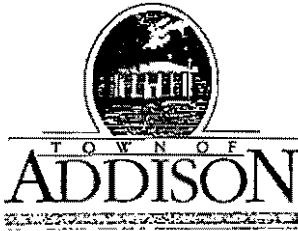

PUBLIC WORKS DEPARTMENT

Post Office Box 144 Addison, Texas 75001

(972) 450-2871

16801 Westgrove

April 2, 1997

MEMORANDUM

TO: Ron Whitehead, City Manager

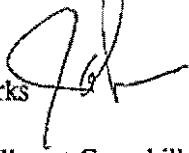
FROM: John Baumgartner, Director of Public Works 

SUBJECT: Acceptance of Traffic Signal on Spring Valley at Greenhill School
Approval of Final Payment to Durable Specialties, Inc.

Durable Specialties, Inc. has completed the above referenced project as per the plans and specifications. Attached is their request for final payment of \$8,383.90.

The original contract amount for the project was \$81,500. The actual work performed by Durable Specialties totaled \$83,839.00, which includes all change orders and reconciliation of the quantities.

Greenhill School paid for the initial design of the signal and for 75% of the construction cost. The Town is paying for the remaining 25% of the construction. The Town budgeted \$25,000 for this project. The Town's share of the construction cost is \$20,959.75.

We have received the consent of surety to final payment, the contractors affidavit of release of liens, and a one year maintenance bond.

Staff recommends that the Council accept the improvements and authorize final payment of \$8,383.90 to Durable Specialties, Inc.

DURABLE SPECIALTIES, INC.

INVOICE
TOWN OF ADDISON
PUBLIC WORKS DEPARTMENT
P. O. BOX 144
ADDISON, TEXAS 75001

DSI PROJ. #609 DATE: 12/24/96
INV. #609-5 WORK END: 11/30/96
EST. NO.: FINAL & RET.
ROUTE: SPRING VALLEY RD. @ GREENVILLE
PROJECT: #96-16

ITEM NO.	DESCRIPTION	EST. QTY	QTY.	PRICE	TOTAL
1	BILLING FOR RETAINAGE SEE ATTACHED INVOICE	1 LS	1	83,839.00	\$83,839.00
					\$0.00
					\$0.00
					\$0.00
					\$0.00
				TOTAL EARNED	83,839.00
				RETAINAGE	
				PREVIOUS PAYMENT	75,455.10
				AMOUNT DUE	8,383.90



Public Works / Engineering
 16801 Westgrove • P.O. Box 144
 Addison, Texas 75001
 Telephone: (214) 450-2871 • Fax: (214) 931-6643

LETTER OF TRANSMITTAL

DATE	8/8/96	JOB NO.
ATTENTION	Gary Oshel	
RE:	Traffic Signal Spring Valley @ Greenhill School	

TO City of Farmers Branch
Engineering Dept.

GENTLEMAN:

WE ARE SENDING YOU

- | | |
|---|---|
| <input checked="" type="checkbox"/> Attached | <input type="checkbox"/> Under separate cover via _____ the following items: |
| <input checked="" type="checkbox"/> Shop Drawings | <input type="checkbox"/> Plans <input type="checkbox"/> Samples <input type="checkbox"/> Specifications |
| <input type="checkbox"/> Copy of letter | <input type="checkbox"/> _____ |
| <input type="checkbox"/> Change order | |

COPIES	DATE	NO.	DESCRIPTION
1			Traffic Signal Foundation for pole T-3
1			" " " " pole T-4

THESE ARE TRANSMITTED as checked below:

- | | | |
|--|---|---|
| <input type="checkbox"/> For approval | <input type="checkbox"/> Approved as submitted | <input type="checkbox"/> Resubmit _____ copies for approval |
| <input type="checkbox"/> For your use | <input type="checkbox"/> Approved as noted | <input type="checkbox"/> Submit _____ copies for distribution |
| <input type="checkbox"/> As requested | <input type="checkbox"/> Returned for corrections | <input type="checkbox"/> Return _____ corrected prints |
| <input checked="" type="checkbox"/> For review and comment | <input type="checkbox"/> _____ | |
| <input type="checkbox"/> FOR BIDS DUE _____ 19____ | <input type="checkbox"/> PRINTS RETURNED AFTER LOAN TO US | |

REMARKS It would be helpful if I could
have your comments this week.

COPY TO _____

SIGNED: David Nijhawong

If enclosures are not as noted, please notify us at once.

AUGUST, 1996 © Copyright 96 Reedcon, Inc. Made in Texas

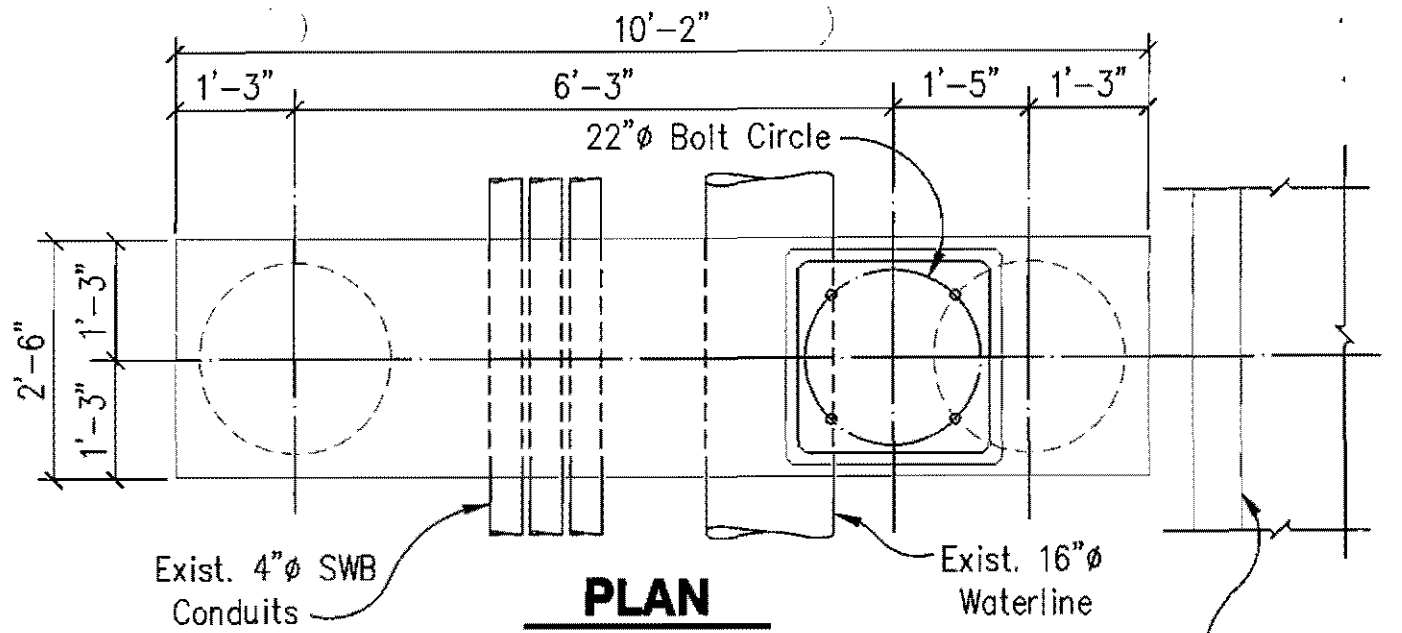

PLAN

SCALE: 1/2" = 1'-0"

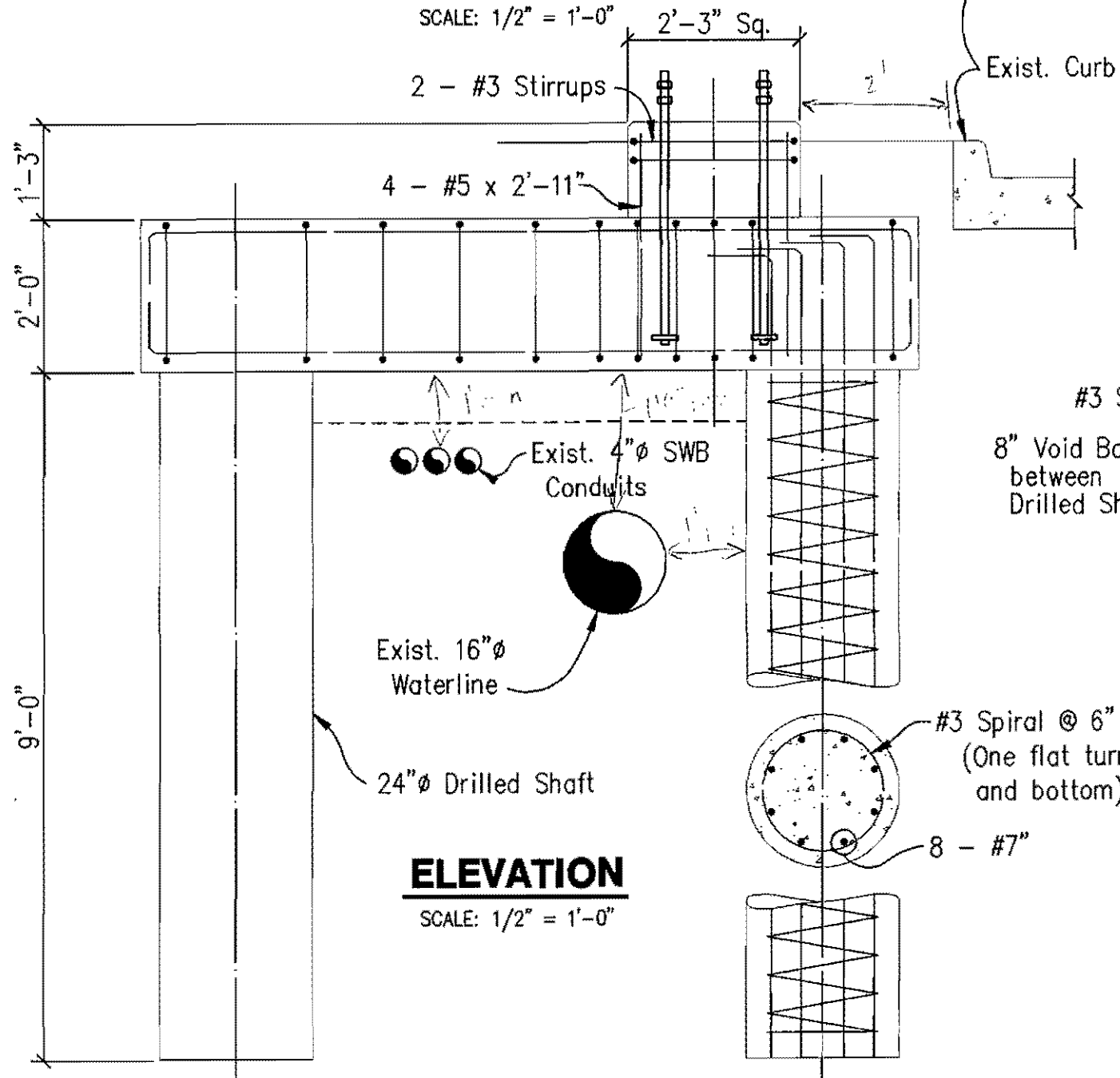

ELEVATION

SCALE: 1/2" = 1'-0"

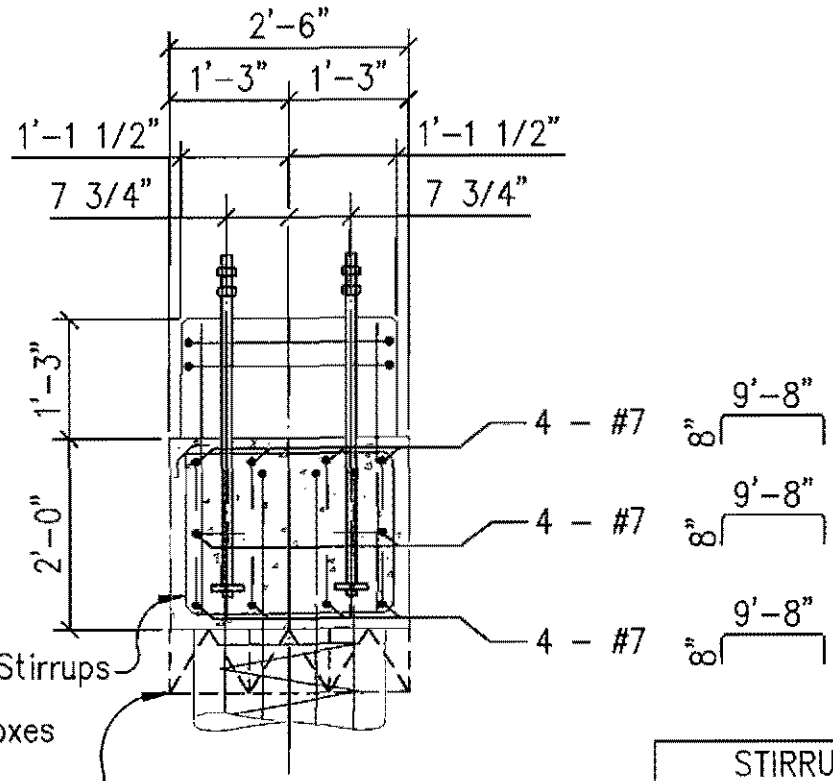

SECTION

SCALE: 1/2" = 1'-0"

1 1/4" Ø Steel Anchor Bolt
(55 ksi Yield Strength)
Galv. top 12"

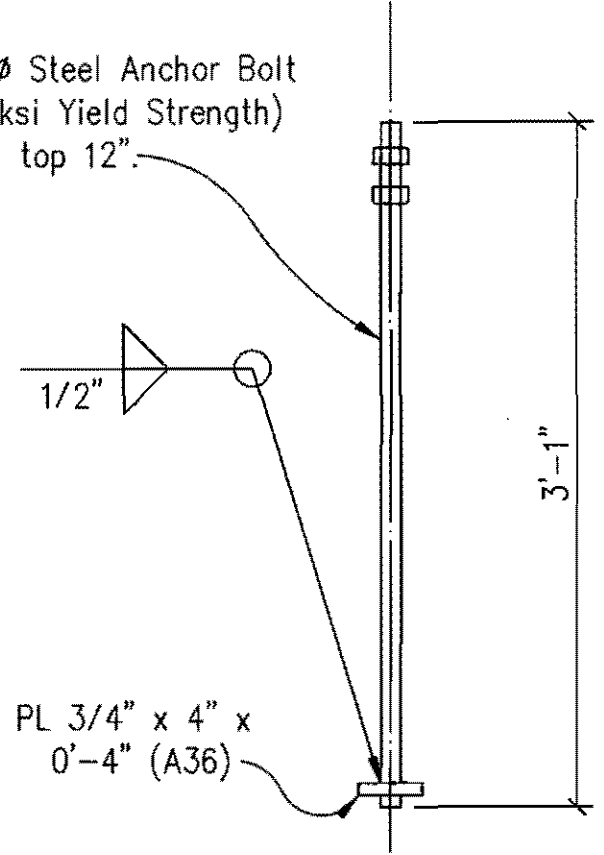

**ANCHOR BOLT
DETAIL**

SCALE: 1" = 1'-0"

STIRRUP SPACING (From end nearest Curb)	
4"	
1'-10"	
4 @ 6"	
10"	
3 @ 12"	
1'-10"	

**PRELIMINARY
FOR INTERIM REVIEW**
NOT FOR CONSTRUCTION PURPOSES
NOT FOR BIDDING PURPOSES
NOT FOR PERMIT PURPOSES

These plans and related specifications were prepared for construction of this specific project only. Reuse of these documents is not permitted without written authorization of Reedcon, Inc.

NOTES

- Concrete - 3,600 psi.
- Reinf. Steel - ASTM A615, Gr. 60

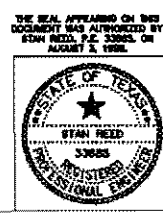

T-4 TRAFFIC SIGNAL FOUNDATION

**SPRING VALLEY at GREENHILL SCHOOL
ADDISON, TEXAS**

Town of ADDISON

REEDCON CONSULTING ENGINEERS
Dallas, Texas

DESIGNED BY: Stan Reed PROJECT: 96036 SHEET NO. 2
DRAWN BY: Stan Reed DATE: AUGUST 5, 1996 OF 2 SHEETS

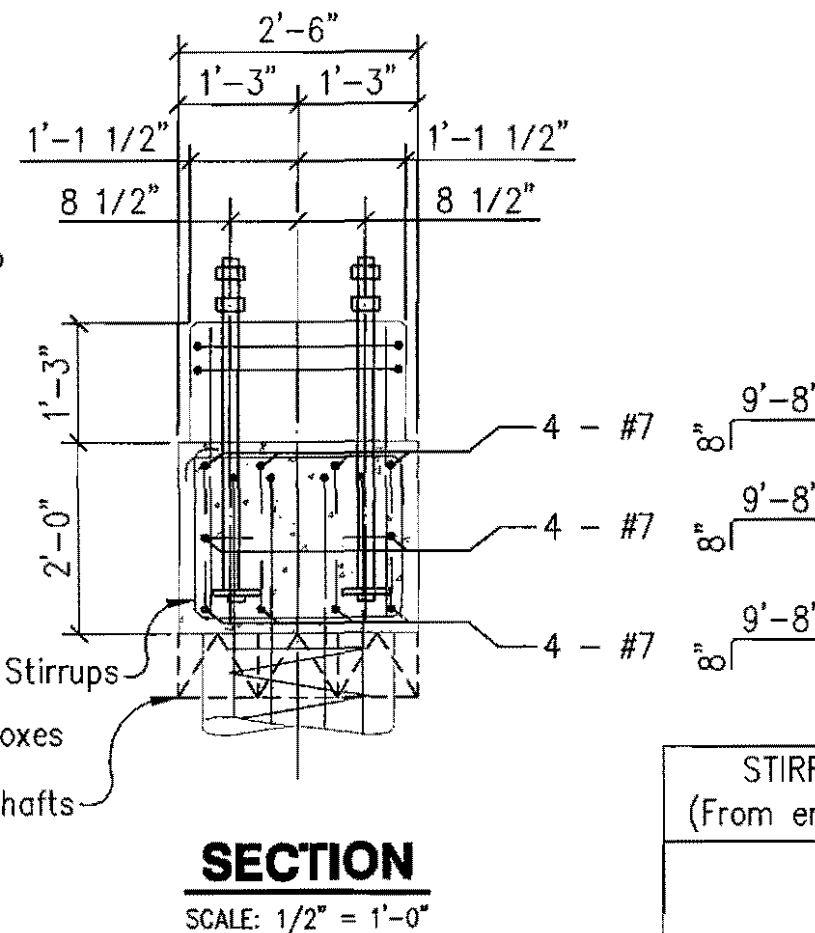
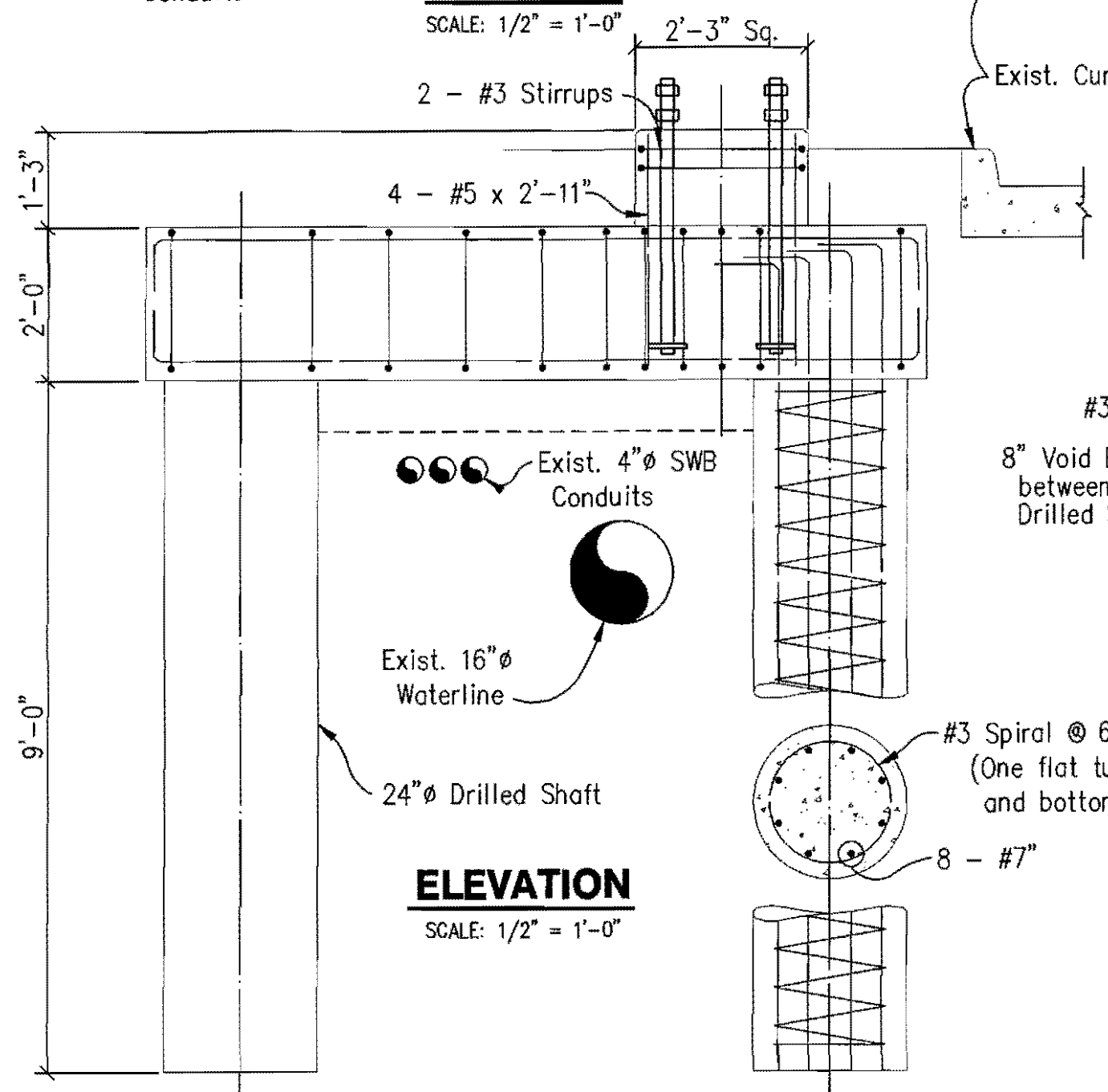
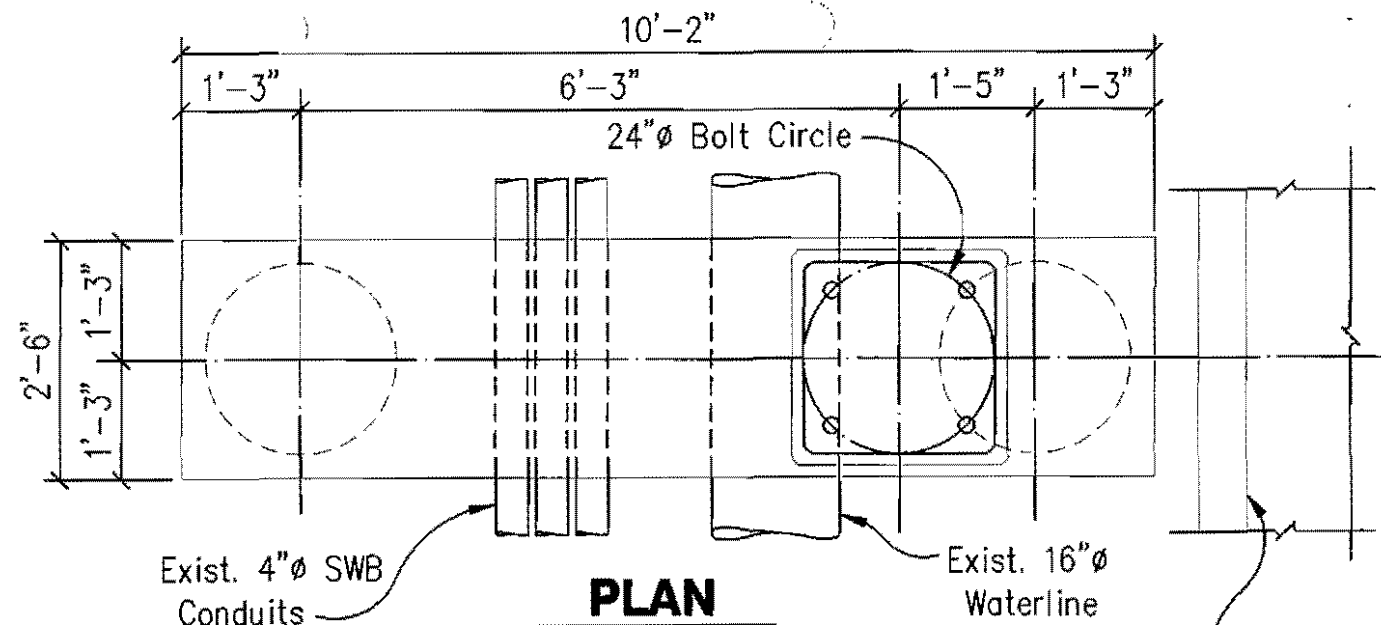

STIRRUP SPACING (From end nearest Curb)

4"
1'-10"
4 @ 6"
10"
3 @ 12"
1'-10"

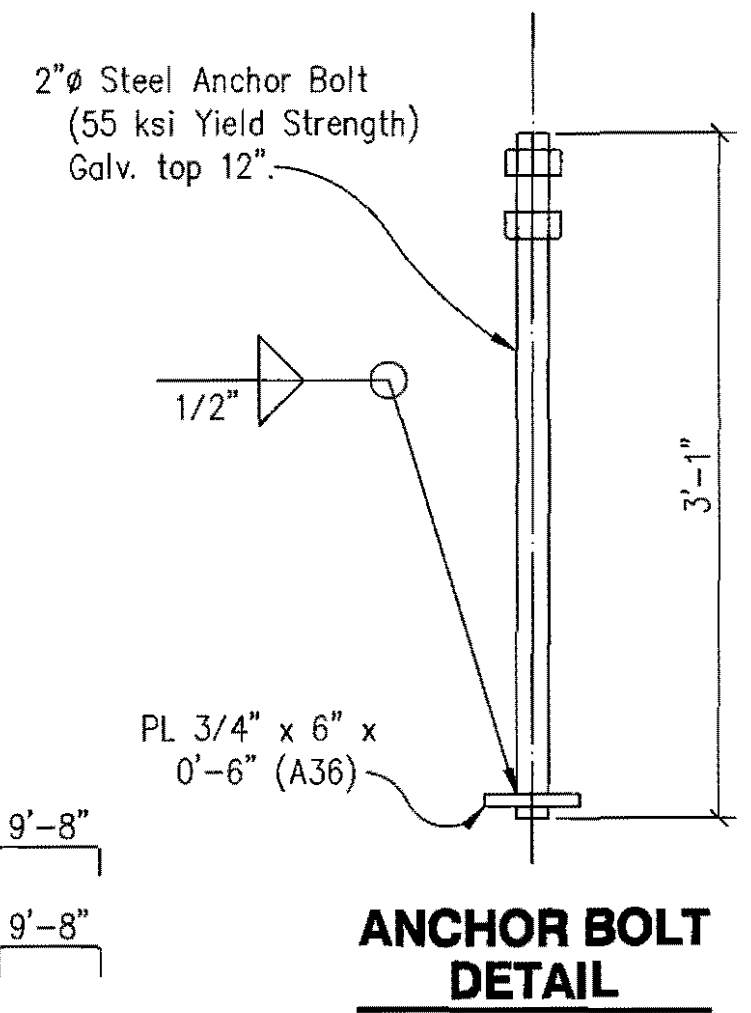

PRELIMINARY FOR INTERIM REVIEW
 NOT FOR CONSTRUCTION PURPOSES
 NOT FOR BIDDING PURPOSES
 NOT FOR PERMIT PURPOSES

These plans and related specifications were prepared for construction of this specific project only. Reuse of these documents is not permitted without written authorization of Reedcon, Inc.

NOTES

- Concrete - 3,600 psi.
- Reinf. Steel - ASTM A615, Gr. 60

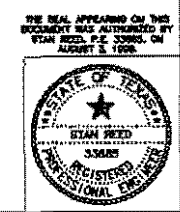

T-3 TRAFFIC SIGNAL FOUNDATION
 SPRING VALLEY at GREENHILL SCHOOL
 ADDISON, TEXAS
Town of ADDISON
REEDCON CONSULTING ENGINEERS
 DALLAS, TEXAS
 DESIGNED BY: Stan Reed PROJECT: 96036 SHEET NO. 1
 DRAWN BY: Stan Reed DATE: AUGUST 5, 1996 OF 2 SHEETS

TOWN OF
ADDISON

PUBLIC WORKS

To: Larry Laske

Company: Durable

FAX #: 780-7411

Date: 8/7/96

of pages (including cover): 3

From: David Nighswonger, P.E.:
Engineering
Phone: 214/450-2879
FAX: 214/931-6643

16801 Westgrove
P.O. Box 144
Addison, TX 75001

Original in mail Per your request FYI Call me

Comments: Please review ~~this~~ drawings and
^{these}
provide an estimate for the additional
cost to construct them. I should have
final drawings to you no later than Friday
depending on what comments Farmers Branch has.

96035 AUGUST, 1996 © Copyright 98 Reedcon, Inc. Made in Texas

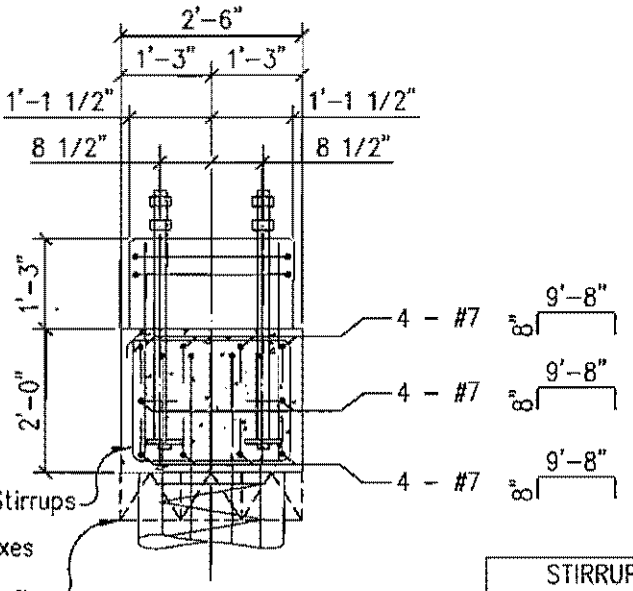
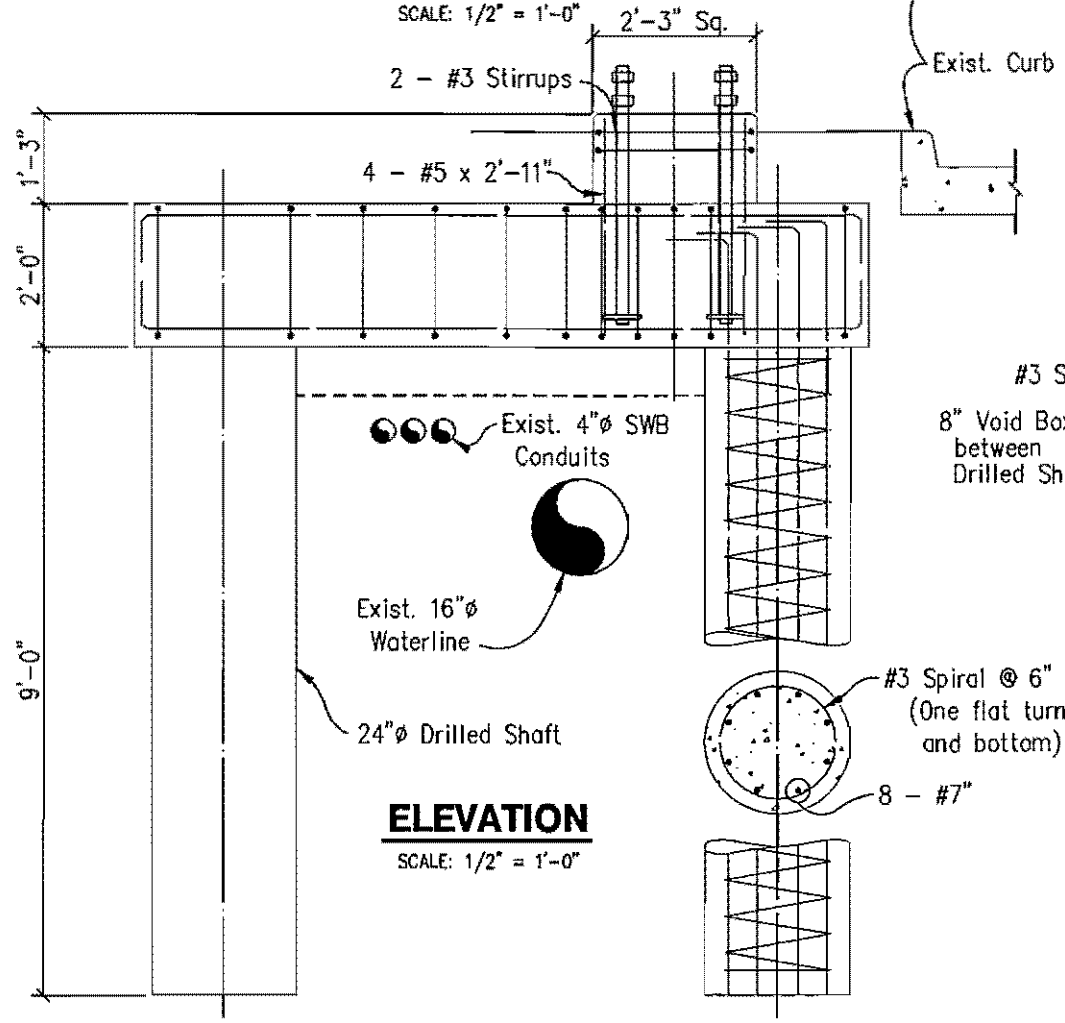
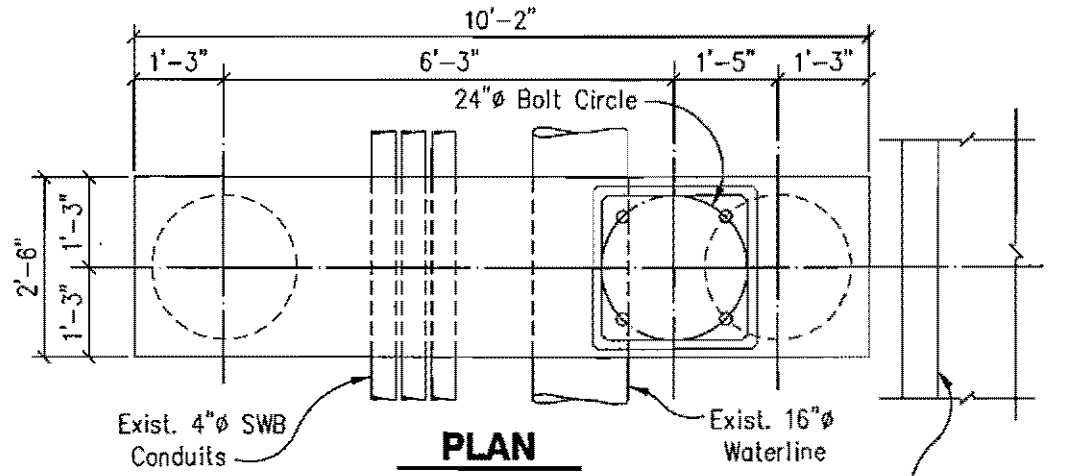

STIRRUP SPACING (From end nearest Curb)	
4"	
1'-10"	
4 @ 6"	
10"	
3 @ 12"	
1'-10"	

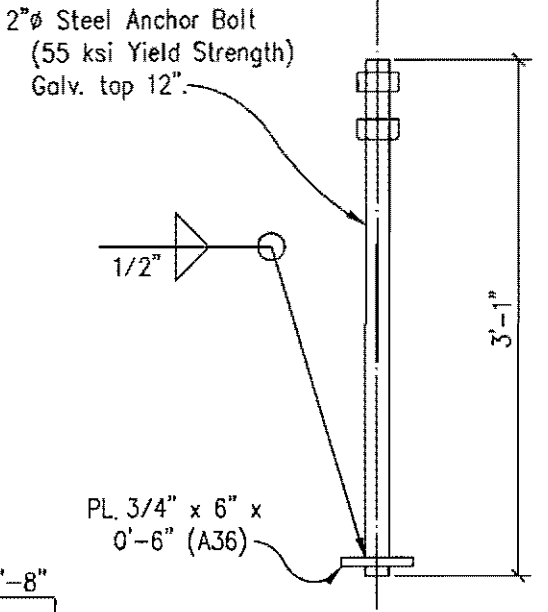

- NOTES**
1. Concrete - 3,600 psi.
 2. Reinf. Steel - ASTM A615, Gr. 60

PRELIMINARY FOR INTERIM REVIEW
 NOT FOR CONSTRUCTION PURPOSES
 NOT FOR BIDDING PURPOSES
 NOT FOR PERMIT PURPOSES

These plans and related specifications were prepared for construction of this specific project only. Reuse of these documents is not permitted without written authorization of Reedcon, Inc.



T-5 TRAFFIC SIGNAL FOUNDATION
 SPRING VALLEY at GREENHILL SCHOOL
 ADDISON, TEXAS
Town of ADDISON
REEDCON
 REEDCON, INC.
 CONSULTING ENGINEERS
 Dallas, Texas
 DESIGNED BY: Stan Reed
 DRAWN BY: Stan Reed
 CHECKED BY: [Blank]
 DATE: AUGUST 3, 1996
 SHEET NO. 1 OF 2 SHEETS

AUGUST, 1996 © Copyright 96 Reedcon, Inc. Made in Texas

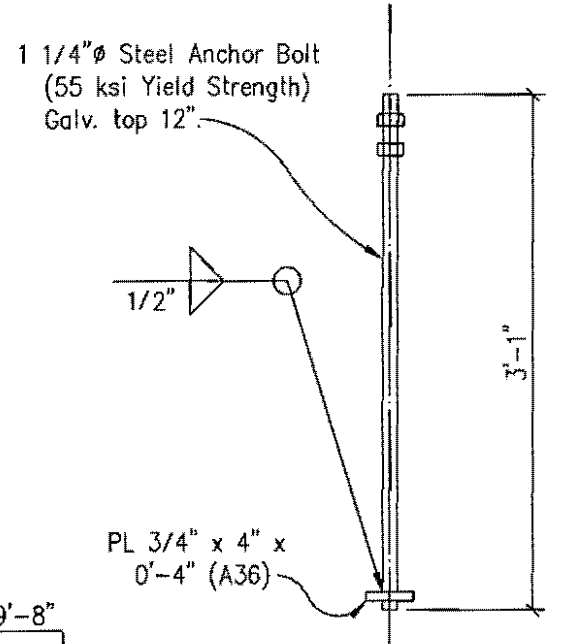
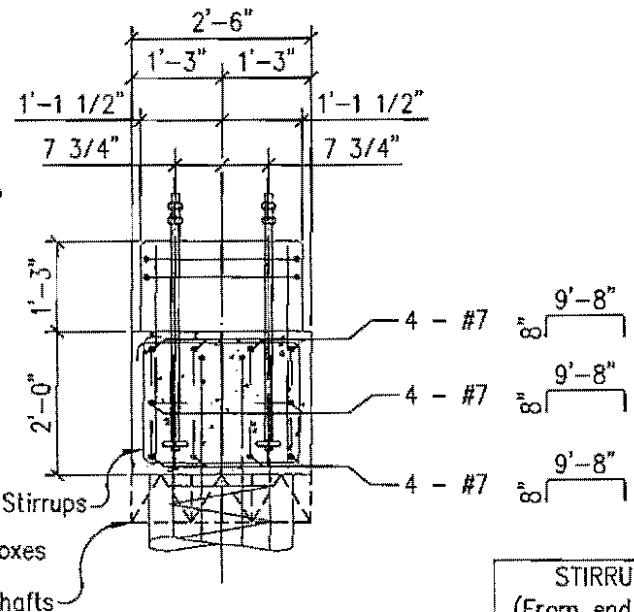
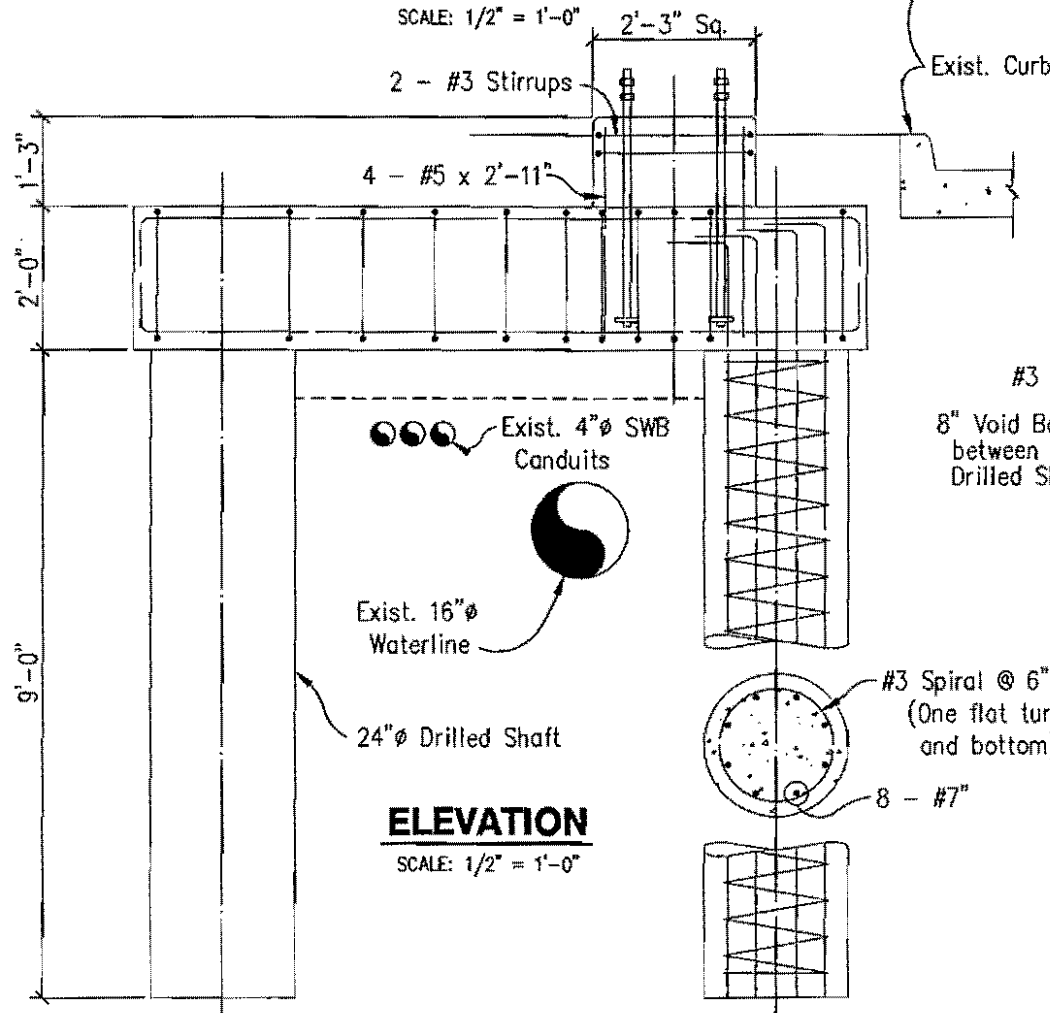
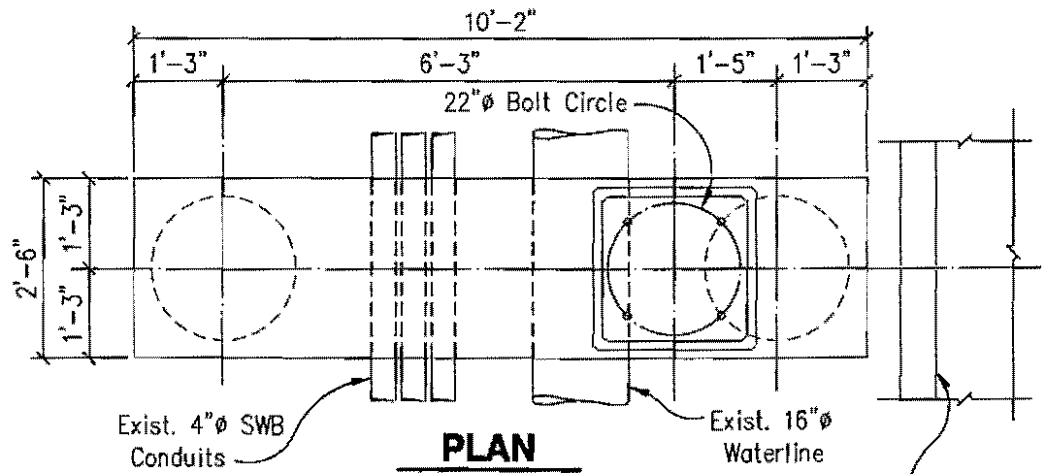

STIRRUP SPACING (From end nearest Curb)	
4"	
1'-10"	
4 @ 6"	
10"	
3 @ 12"	
1'-10"	

PRELIMINARY FOR INTERIM REVIEW
 NOT FOR CONSTRUCTION PURPOSES
 NOT FOR BIDDING PURPOSES
 NOT FOR PERMIT PURPOSES

These plans and related specifications were prepared for construction of this specific project only. Review of these documents is not permitted without written authorization of Reedcon, Inc.

- NOTES**
- Concrete - 3,600 psi.
 - Reinf. Steel - ASTM A615, Gr. 60



T-4 TRAFFIC SIGNAL FOUNDATION
 SPRING VALLEY at GREENHILL SCHOOL
 ADDISON, TEXAS
Town of ADDISON
REEDCON CONSULTING ENGINEERS
 PROJECT: 96038
 SHEET NO. 2 OF 2 SHEETS
 DESIGNED BY: Stan Reed
 DRAWN BY: Stan Reed
 DATE: AUGUST 5, 1996

June 13, 1995

Mr. Ken Piel
Greenhill School
14255 Midway Road
Dallas, Texas 75244

Re: Proposal for preparation of design plans and specifications for installation of traffic signal on Spring Valley Road at Greenhill School.

Dear Mr. Piel:

Thank you for contacting me concerning the preparation of design plans and specifications for the installation of a traffic signal at the intersection of the Greenhill School Driveway and Spring Valley Road in Addison, Texas. I have prepared this proposal based on a telephone conversation with Mr. John Baumgartner, Director of Public Works, Town of Addison. If accepted by you, this proposal will become a Letter of Agreement between Greenhill School and Jack Hatchell & Associates for the Scope of Services described below.

SCOPE OF SERVICES

1. I will prepare plans for the new traffic signals to include signal poles, signal heads, detectors and other necessary traffic signal materials and equipment in accordance with Town of Addison standards.
2. I will prepare specifications for traffic signal equipment and the installation of same using Town of Addison specifications.
3. I will prepare timing plans for the traffic signal based on coordinated traffic flow along Spring Valley Road.
4. Bid documents will be prepared using Town of Addison bid specifications.
5. After review of the plans, specifications and bid documents by the Town of Addison and City of Farmers Branch, I will make any necessary corrections and furnish a corrected copy to the Town of Addison for bidding.

- Interconnect
- Cost Estimate

- Direct Costs - Reimbursable

FEE AND METHOD OF PAYMENT

The fee for providing the services described above is \$3,500.00. An invoice for 90% of the fee (\$3,150.00) will be submitted upon transmittal of the plans and specifications to the Town of Addison for review. The remaining fee (\$350.00) will be due upon completion of the bidding process.

AUTHORIZATION

I am prepared to initiate work on this project immediately following receipt of an executed copy of this Letter of Agreement. I anticipate completion of the plans, specifications and bid documents within three weeks following authorization to proceed.

Again, thank you very much for providing me the opportunity to provide these professional transportation engineering services. Please do not hesitate to call me if you have any questions or need additional information.

Sincerely,

Jack Hatchell, P.E.

APPROVED:

Signature

(Typed or Printed Name)

AUTHORIZED TO EXECUTE
AGREEMENTS FOR:

Date

Greenhill School

Barton-Aschman Associates, Inc.
5485 Belt Line Road, Suite 199 • Dallas, Texas 75240 • (214) 991-1900 • Fax: (214) 490-9261

June 16, 1995

Mr. Ken Piel
Business Manager
Greenhill School
14255 Midway Road
Addison, Texas 75244

RE: Proposal for Traffic Signal Design for the Greenhill School

Dear Mr. Piel:

Barton-Aschman Associates, Inc. is pleased to submit this proposal to provide professional transportation engineering services in connection with the design of the traffic signal installation at the Greenhill School entrance on Spring Valley. We have prepared a scope of services "menu" and fee estimate based on our recent discussion and our knowledge of Town of Addison design standards.

If accepted, this letter will become an agreement between the Greenhill School (CLIENT) and Barton-Aschman Associates, Inc. (BA) to provide the services outlined in the Scope of Services presented below:

SCOPE OF SERVICES

Our Scope of Services encompasses the work effort involved in the traffic signal design and corresponding timing plan development at the intersection of the school's main entrance and Spring Valley Road west of Midway Road. Depending on initial discussion's with Town of Addison staff, we can also develop construction documents for a hardwire interconnect traffic signal system.

Task 1 - Data Collection

- 1.1 Obtain base plans (e.g., paving plans) from the Town of Addison and verify plans in the field. If existing base plans are not available, the intersection will be drawn based on field measurements which include roadway widths, lane widths, and curb radii. This assumes that BA will not have to survey the intersection.
- 1.2 Assemble the following existing data and information:
 - Signal hardware
 - 24-hour turning movement counts
 - Intersection turning movement counts

- Geometric and intersection configurations
 - Existing signal timing data
 - Arterial link data
- 1.3 Collect AM, Off, and PM peak hour turning movement counts for the intersections of Spring Valley at Greenhill School entrance, at Midway, and at Proton.
 - 1.4 Meet with Town of Addison staff to discuss design standards and signal coordination preferences.

Task 2 - Signal Plan Design

- 2.1 Prepare intersection base map using a scale of 1"=20'. The base map will be based on the information collected in Task 1. The base map will be printed on a 24" x 36" sheet.
- 2.2 Prepare traffic signal construction layout on base plan. This sheet will include proposed pole locations, controller location, conduit runs, wiring table, detector locations, signal head designations, power source and other design features.
- 2.3 Prepare signing and pavement marking plans.
- 2.4 Incorporate appropriate standard detail sheets.
- 2.5 Review with the Town of Addison. Incorporate all comments.
- 2.6 Prepare a list of materials and general notes based on the approved preliminary sheets.
- 2.7 Prepare probable quantity and cost estimates.
- 2.8 Prepare plan set title sheet and incorporate standard traffic control plan sheet.
- 2.9 Revise Town of Addison signal specifications, as necessary, to conform with this project.

Task 3 - Generation of Traffic Signal Timing Plans

- 3.1 Using turning movement volumes and 24-hour volumes collected previously,

develop coordinated timing plans for Spring Valley at the cross-streets of Greenhill School, Midway, and Proton.

- 3.2 Prepare timing plan sheet for incorporation into plans.
- 3.3 Assist Town of Addison in the implementation and fine-tuning of the actuated and coordinated timing plans.

Task 4 - Hardwire Interconnect Design

- 4.1 Based on the results of Task 1.4 collect base map information between the Greenhill School entrance and Proton as well as prepare roadway base maps using a scale of 1"=40'. The base map(s) will be printed on a 24" x 36" sheet.
- 4.2 Determine most cost effective interconnect alternative and verify with the Town of Addison.
- 4.3 Prepare hardwire interconnect construction layout on base plan. This sheet will show interconnect routing, pull box locations, conduit size, type, and installation procedure, as well as, estimated quantities.

Task 5 - As-Built Plans

- 5.1 Revise plans to include any in-field changes.
- 5.2 Deliver as-built plans to the Town of Addison.

MEETINGS

For the purpose of our budget and fee estimate, we have identified three (3) formal meetings with the local agencies. Additional meetings authorized by the CLIENT will be billed on a cost basis and are not reflected in our fee estimate.

DELIVERABLES

BA will deliver the following products for each phase:

1. Three (3) copies of the preliminary signal layouts.
2. Ten (10) full sized (24" x 36") sets of the final signal plans and specifications.
3. Original mylar reproducible set and five (5) bluelines of the as-built signal plans.

Mr. Ken Piel
June 16, 1995
Page 4

4. Construction cost estimate letter.

FEE FOR SERVICES AND METHOD OF PAYMENT

The fee for completing the project will be based on our hourly rates for staff personnel, current at the time of performance, for staff services rendered. The maximum fee and expenses for completion of Tasks 1 through 4 are highlighted below and will not exceed \$13,110.00 without prior written authorization from the CLIENT.

<u>Task Description</u>	<u>Cost</u>
Task 1 - Data Collection	\$880.00
Task 2 - Signal Plan Design	\$5,600.00
Task 3 - Generation of Traffic Signal Timing Plans	\$2,700.00
Task 4 - Hardwire Interconnect Design	\$3,450.00
Task 5 - As-Built Plans	<u>\$480.00</u>
	\$13,110.00

The fee for extra services, meetings, work sessions, and presentations (and work in addition to the tasks indicated in the Scope of Services) will be billed separately based on our hourly rates for staff time and expense.

Direct reimbursement for out-of-pocket expenses such as mileage, reproduction, etc., will be billed at cost and will be added to the staff time costs incurred on the project.

Invoices will be submitted monthly and will indicate charges incurred during the preceding month. Billings are due and payable within thirty (30) days of invoice date.

AUTHORIZATION

We are prepared to initiate work on this project upon receipt of a signed copy of this Letter of Agreement.

Mr. Ken Piel
June 16, 1995
Page 5

We appreciate the opportunity to submit this proposal and look forward to assisting you on this project. If you have any questions regarding this proposal, please do not hesitate to call.

Sincerely,

BARTON-ASCHMAN ASSOCIATES, INC.

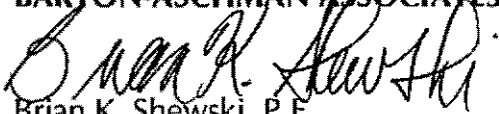
Brian K. Shewski, P.E.
Senior Associate

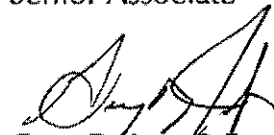
Gary D. Jost, P.E.
Vice President

BKS:dw

Date: _____

ACCEPTED AND APPROVED BY

(Signature)

(Printed or Typed Name)

(Title)

**AUTHORIZED TO EXECUTE
AGREEMENTS FOR:**

(Organization)

(Title)



DeShazo, Tang & Associates, Inc.

Engineers - Planners

330 Union Station, Dallas, Texas 75202

Telephone: (214) 748-6740

FAX: (214) 748-7037

Telecopier Transmittal

Date Faxed: 6.15.95

From: JOHN DESHAZO

Project: GREENHILL SCHOOL

Project Number: SIGNAX

Transmitted to:

Name: MR. KEN PIERCE

Company: _____

City/State: _____

FAX Number: 404-8217 Telephone Number: _____

- FYI
- Response
- Requested Due Date: _____

Message: _____

Counting this cover letter, we are transmitting 3 pages.

If all pages are not received, please call:

at (214) 748-6740



DeShazo, Tang & Associates, Inc.
 Engineers ♦ Planners
 400 South Houston, Suite 330
 Dallas, Texas 75202-4802
 214/748-6740 ♦ Metro 214/263-5428
 FAX 214/748-7037

June 15, 1995

Mr. Kenneth Piel
 Greenhill School
 14255 Midway Road
 Addison, Texas 75244

RE: Traffic Signal Design for Spring Valley & Greenhill School Intersection; 95071

Dear Mr. Piel:

We are pleased to submit this proposal to provide professional transportation engineering services to the Greenhill School to prepare traffic signal design plans and specifications for the intersection of the driveway to Greenhill School and Spring Valley Road.

If accepted, this will become a Letter of Agreement between Greenhill School and DeShazo, Tang & Associates to prepare traffic signal design plans and specifications for the subject intersection in accordance with the following tasks.

- TASK 1 -** Meet with the City of Addison to establish standards and direction for the development of the signal design.
- TASK 2 -** Make appropriate site and traffic reconnaissance to identify various physical constraints relative to the location of the traffic signal standards.
- TASK 3 -** Develop and review preliminary traffic signal concepts with the Greenhill School and city staff.
- TASK 4 -** Prepare intersection signal construction plans and specification for procurement and installation of the traffic signal design.

LIMITATIONS ON LIABILITY

Limitations on liability help to keep our fee structure as low as possible. The client agrees to limit the liability of DeShazo, Tang and Associates, Inc. to the client and to any and all contractors and subcontractors on the project, due to negligent acts, errors or omissions by DeShazo, Tang & Associates, Inc. such that the total aggregate liability of the firm to all those named shall not exceed \$50,000 or the total fee for services rendered on this project, whichever is greater.

PROJECT STAFF

Tony Trammel, P.E., will serve as principal-in-charge and project manager. Appropriate planning and design staff will assist.

- Timing Plan?
 - Reimbursable
 - Interconnect

Mr. Kenneth Piel
June 15, 1995
Page 2

FEE FOR SERVICES

The professional services proposed will be performing for a fee of \$8,500.

We are prepared to initiate work on this project upon receipt of a signed copy of this Letter of Agreement. We appreciate the opportunity to submit this proposal and look forward to assisting you on this project.

Sincerely,

DeSHAZO, TANG & ASSOCIATES, INC.

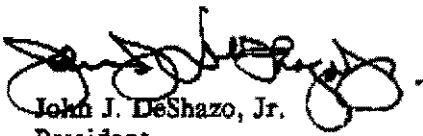

John J. DeShazo, Jr.
President

JJD:ar

THIS AGREEMENT ACKNOWLEDGED AND ACCEPTED

BY: _____ DATE: _____

TITLE: _____

JACK HATCHELL & ASSOCIATES
CONSULTING ENGINEERING

P. O. Box 260119
Plano, Texas 75026-0119
(214) 424-1368

June 7, 1996

Mr. David C. Nighswonger, P.E.
Engineering
Town of Addison
P.O. Box 144
Addison, Texas 75001

Dear Mr. Nighswonger:

Please find enclosed Invoice No. 1 for professional transportation engineering services rendered in connection with the preparation of traffic signal timing plans for the new traffic signal at Spring Valley Road and Greenhill School. This invoice is for the traffic counts performed by Metrocount.

If you find this invoice to be in order, I will appreciate receiving payment in the amount of \$ 280.80.

Thank you and the Town of Addison for providing me the opportunity to provide these services. Please do not hesitate to call if you have any questions or need additional information.

Sincerely,

Jack Hatchell, P.E.

INVOICE NO. 1

For professional transportation engineering services rendered in connection with the preparation of traffic signal timing plans for Spring Valley Road and Greenhill School.

Direct Expenses

Traffic Counts (Metrocount)	280.80
-----------------------------	--------

Total Amount Due This Invoice	\$ 280.80
-------------------------------	------------------

Please make check payable to Jack Hatchell and remit to address below.

Jack Hatchell
P.O. Box 260119
Plano, Texas 75026-0119

Thank you.

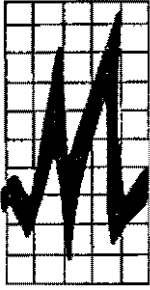

METROCOUNT
Traffic Data Collection

INVOICE

CLIENT JACK HATCHELL and ASSOCIATES

P.O. Box 260119

Plano, Texas 75026-0119

DATE May 29, 1996

INVOICE NO. 06-06

REMIT TO:

METROCOUNT

3800 Beaumont Lane
Plano, Texas 75023

(214) 618-0663

Payment is due 30 days from
date of invoice. After 60 days,
a late charge of 5% per month
will be added.

For traffic data collected at Greenhill School.

PERSONNEL & EQUIPMENT	
6 tubes	\$270.00
DIRECT EXPENSES	
36 miles	<u>10.80</u>
TOTAL AMOUNT DUE	<u>\$280.80</u>

Thank you,
J. Hope Higinbotham
T. Hope Higinbotham
METROCOUNT



Engineers, Inc.

Grantham, Burge & Waldbauer

INVOICE

Mr. John Baumgartner, PE
Director of Public Works
Town of Addison
16801 Westgrove Drive
Addison, Texas 75001

Invoice No.: 19

Date: May 4, 1996

GBW Project No.: 96-011

PROJECT: Greenhill/Spring Valley Traffic Signal Review

INVOICE SUMMARY

From 04/01/96 to 04/30/96

Total Due This Invoice	\$ 444.59
Total Previous Invoices	\$ 1,352.14
Less Payments/Credits	(\$ 0.00)

Total Amount Now Due	\$ 1,796.73
----------------------	-------------

**Please Retain This
Page For Your Records**

Invoice No.: 19
Date: May 4, 1996
Project: Greenhill/Spring Valley Traffic Signal Review

Greenhill/Spring Valley Traffic Signal Review

Labor Costs

ENGINEER

Grantham, Bruce	<u>4</u>	
ENGINEER TOTAL:	4	<u>201.68</u>

Subtotal Salary Cost \$ 201.68

Overhead Multiplier (2.0) 2.0

Labor Costs - Total \$ 403.36

>>> REDUCE TO CONTRACT LIMIT (\$1,300) \$ 400.04

Non-Labor Costs

Travel/Mileage \$ 40.50

Subtotal \$ 40.50

10% Handling \$ 4.05

Non-Labor Costs - Total \$ 44.55

TOTAL DUE >>> \$ 444.59 ✓ DCN



Engineers, Inc.

Grantham, Burge & Waldbauer

Mr. John Baumgartner, PE
Director of Public Works
Town of Addison
16801 Westgrove Drive
Addison, Texas 75001

Invoice No.: 19

Date: May 4, 1996

GBW Project No.: 96-011

PROJECT: Greenhill/Spring Valley Traffic Signal Review

REMITTANCE PAGE:

Total Current Invoice \$ 444.59

TOTAL AMOUNT ENCLOSED \$ _____

Pay to the Order Of:

GBW Engineers, Inc.
1919 S. Shiloh Road
Suite 530
L.B. 27
Garland, Texas 75042

**Please Return This Page With Payment
For Prompt And Accurate Credit**



Engineers, Inc.

Grantham, Burge & Waldbauer

INVOICE

Mr. John Baumgartner, PE
Director of Public Works
Town of Addison
16801 Westgrove Drive
Addison, Texas 75001

Invoice No.: 8

Date: April 1, 1996

GBW Project No.: 96-011

PROJECT: Greenhill/Spring Valley Traffic Signal Review

INVOICE SUMMARY

From 03/01/96 to 03/31/96

Total Due This Invoice	\$ 1,352.14
Total Previous Invoices	\$ 0.00
Less Payments/Credits	(\$ 0.00)

Total Amount Now Due	\$ 1,352.14
----------------------	-------------

**Please Retain This
Page For Your Records**

Invoice No.: 8
Date: April 1, 1996
Project: Greenhill/Spring Valley Traffic Signal Review

Greenhill/Spring Valley Traffic Signal Review

Labor Costs

ENGINEER

Grantham, Bruce	8	
Waldbauer, Jim	<u>1</u>	
ENGINEER TOTAL:	9	<u>449.98</u>

Subtotal Salary Cost	\$ 449.98
Overhead Multiplier (2.0)	2.0
Labor Costs - Total	\$ 899.96

Non-Labor Costs

Thomas Reprographics	\$ 149.13
The Secretarial Center	\$ 155.16
Kinko's Copies	\$ 106.78

Subtotal	\$ 411.07
10% Handling	\$ 41.11
Non-Labor Costs - Total	\$ 452.18

TOTAL DUE >>> \$ 1,352.14

✓ DCN



Engineers, Inc.

Grantham, Burge & Waidbauer

Mr. John Baumgartner, PE
Director of Public Works
Town of Addison
16801 Westgrove Drive
Addison, Texas 75001

Invoice No.: 8
Date: April 1, 1996
GBW Project No.: 96-011

PROJECT: Greenhill/Spring Valley Traffic Signal Review

REMITTANCE PAGE:

Total Current Invoice	\$	1,352.14
TOTAL AMOUNT ENCLOSED	\$	_____

Remittance Address: GBW Engineers, Inc.
1919 S. Shiloh Road
Suite 530
L.B. 27
Garland, Texas 75042

Please Return This Page With Payment
For Prompt And Accurate Credit

STATE OF TEXAS §
 COUNTY OF DALLAS §

SIGNAL PARTICIPATION AGREEMENT

This Signal Participation Agreement is entered into this 20th day of May, 1996 by and between the Town of Addison, Texas (the "City") and Greenhill School ("Greenhill").

RECITALS

1. Greenhill is a private school located within the City, with its southern border lying along the north side of Spring Valley Road. The Greenhill campus is accessible by motor vehicles from Spring Valley.
2. When large volumes of motor vehicles are accessing Greenhill from Spring Valley, traffic congestion results and causes delays for those entering into and exiting from the Greenhill campus.
3. The City and Greenhill agree that a traffic signal (the "traffic signal") controlling traffic accessing Greenhill from Spring Valley is necessary in order to improve the traffic circulation at that site, and the City and Greenhill desire to cooperate in the acquisition and installation of that signal.
4. The City has heretofore solicited bids for the traffic signal in accordance with State law, has awarded the bid to acquire and construct the traffic signal to Durable Specialties, and has entered into a contract with Durable Specialties for the acquisition and construction of the traffic signal (the "Construction Contract") in the amount of \$81,500.

NOW, THEREFORE, for and in consideration of the above and foregoing premises, the benefits flowing to each of the parties hereto, and other good and valuable consideration, the Town of Addison, Texas and Greenhill School do hereby contract and agree as follows:

Section 1. Traffic signal. The duties and obligations of the City and Greenhill with respect to the traffic signal shall be as follows:

A. Cost:

1. Percentage allocation: The City shall pay 25% and Greenhill shall pay 75% of the cost of the Construction Contract, as may be modified by change order.
2. Time of payment:
 - (a) City: The City shall pay Durable Specialties in accordance with the Construction Contract.
 - (b) Greenhill: Greenhill shall pay to the City, as reimbursement for the City's payment to Durable Specialties under the Construction Contract, its percentage

allocation as set forth herein. In accordance therewith, upon the execution of this Agreement Greenhill shall pay to the City the sum of \$30,500.00, with the balance of the reimbursement to be paid to the City in accordance with the following: Upon the activation of the traffic signal, the City shall send to Greenhill an invoice reflecting the balance of the percentage owed by Greenhill, and Greenhill shall pay the City the amount of the invoice within 30 days thereof.

B. **Construction management:** The City shall serve as the owner and construction manager under the Construction Contract.

Section 2. Notices. Where the terms of this Agreement require that notice in writing be provided, such notice shall be deemed delivered three (3) days following the deposit of the notice in the United States mail, postage prepaid, and sent by certified mail, return receipt requested and properly addressed as follows:

TO TOWN OF ADDISON:

P.O. Box 144
Addison, Texas 75001

Attn: City Manager

TO GREENHILL SCHOOL:

Kenneth A. Piel
14255 Midway Road
Dallas, Texas 75244-3698

Section 3. Incorporation of Recitals. The recitals set forth herein are intended, and are hereby deemed, to be a part of this Agreement.

Section 4. Authority to execute. The undersigned officers and/or agents of the parties hereto are the properly authorized officials and have the necessary authority to execute this Assignment on behalf of the parties hereto, and each party hereby certifies to the other that any necessary resolutions or other act extending such authority have been duly passed and are now in full force and effect.

Section 5. Binding effect. This Assignment shall be binding upon and inure to the benefit of the successors and assigns of the parties hereto.

EXECUTED at Dallas County, Texas on the day and year first written above.

TOWN OF ADDISON, TEXAS

GREENHILL SCHOOL

By: R. Whitehead
Ron Whitehead, City Manager

By: [Signature]

ATTEST:

Its: Director of Finance and Operations

By: C. MORAN
Carmen Moran, City Secretary

TOWN OF ADDISON
Miscellaneous Cash
05-16-96 12:03:45

Receipt # 228787
Account # CK # 017417
DEVELOPER CONTRIBUTION FROM GREENHILL SC
HOOE FOR TRAFFIC SIGNAL
Amount tendered > 30,500.00

Item paid Amount paid
410004071100000000 30,500.00

Change returned > 0.00

THANK YOU

Your cashier RAE

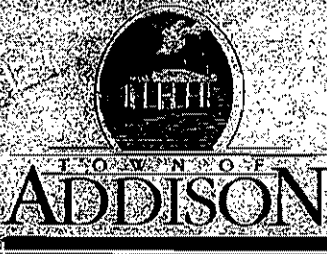

TOWN OF ADDISON
P.O. BOX 144
ADDISON, TEXAS 75001
TELEPHONE: (214) 233-1331

STATEMENT
NO. 6900

05/08/96

Mr. Ken Piel
Greenhill School
14255 Midway Road
Dallas, Texas 75244-3698

TOWN OF ADDISON
P.O. BOX 144
ADDISON, TEXAS 75001

Fold along this line

5/8

Partial reimbursement for traffic signal
Spring Valley at Greenhill School entrance

\$30,500

03-1710

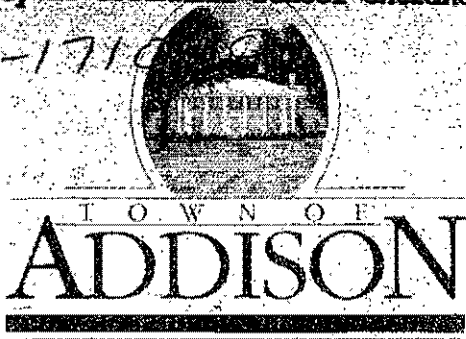

REMITTANCE COPY

Fold along this line

PREPARED BY: A. Hernandez

TOTAL AMOUNT DUE \$30,500

ACCOUNT CHARGED:

TERMS: Due upon receipt of Statement

TO INSURE PROPER CREDIT - RETURN
REMITTANCE COPY WITH PAYMENT.

REMITTANCE COPY

INVOICE NO.	INVOICE DATE	DESCRIPTION	AMOUNT	DISCOUNT	NET AMOUNT
6900	05/08/96	TRAFFIC SIGNAL	\$30,500.00	\$0.00	\$30,500.00
			\$30,500.00	\$0.00	\$30,500.00

*Developer Contribution
Greenhill School
Traffic Signal*

41-600-48711

STATE OF TEXAS §
 §
COUNTY OF DALLAS §

SIGNAL PARTICIPATION AGREEMENT

This Signal Participation Agreement is entered into this 20th day of May, 1996 by and between the Town of Addison, Texas (the "City") and Greenhill School ("Greenhill").

RECITALS

1. Greenhill is a private school located within the City, with its southern border lying along the north side of Spring Valley Road. The Greenhill campus is accessible by motor vehicles from Spring Valley.

2. When large volumes of motor vehicles are accessing Greenhill from Spring Valley, traffic congestion results and causes delays for those entering into and exiting from the Greenhill campus.

3. The City and Greenhill agree that a traffic signal (the "traffic signal") controlling traffic accessing Greenhill from Spring Valley is necessary in order to improve the traffic circulation at that site, and the City and Greenhill desire to cooperate in the acquisition and installation of that signal.

4. The City has heretofore solicited bids for the traffic signal in accordance with State law, has awarded the bid to acquire and construct the traffic signal to Durable Specialties, and has entered into a contract with Durable Specialties for the acquisition and construction of the traffic signal (the "Construction Contract") in the amount of \$81,500.

NOW, THEREFORE, for and in consideration of the above and foregoing premises, the benefits flowing to each of the parties hereto, and other good and valuable consideration, the Town of Addison, Texas and Greenhill School do hereby contract and agree as follows:

Section 1. Traffic signal. The duties and obligations of the City and Greenhill with respect to the traffic signal shall be as follows:

A. Cost:

1. *Percentage allocation:* The City shall pay 25% and Greenhill shall pay 75% of the cost of the Construction Contract, as may be modified by change order.

2. *Time of payment:*

(a) City: The City shall pay Durable Specialties in accordance with the Construction Contract.

(b) Greenhill: Greenhill shall pay to the City, as reimbursement for the City's payment to Durable Specialties under the Construction Contract, its percentage

allocation as set forth herein. In accordance therewith, upon the execution of this Agreement Greenhill shall pay to the City the sum of \$30,500.00, with the balance of the reimbursement to be paid to the City in accordance with the following: Upon the activation of the traffic signal, the City shall send to Greenhill an invoice reflecting the balance of the percentage owed by Greenhill, and Greenhill shall pay the City the amount of the invoice within 30 days thereof.

B. Construction management: The City shall serve as the owner and construction manager under the Construction Contract.

Section 2. Notices. Where the terms of this Agreement require that notice in writing be provided, such notice shall be deemed delivered three (3) days following the deposit of the notice in the United States mail, postage prepaid, and sent by certified mail, return receipt requested and properly addressed as follows:

TO TOWN OF ADDISON:

P.O. Box 144
Addison, Texas 75001

Attn: City Manager

TO GREENHILL SCHOOL:

Kenneth A. Piel
14255 Midway Road
Dallas, Texas 75244-3698

Section 3. Incorporation of Recitals. The recitals set forth herein are intended, and are hereby deemed, to be a part of this Agreement.

Section 4. Authority to execute. The undersigned officers and/or agents of the parties hereto are the properly authorized officials and have the necessary authority to execute this Assignment on behalf of the parties hereto, and each party hereby certifies to the other that any necessary resolutions or other act extending such authority have been duly passed and are now in full force and effect.

Section 5. Binding effect. This Assignment shall be binding upon and inure to the benefit of the successors and assigns of the parties hereto.

EXECUTED at Dallas County, Texas on the day and year first written above.

TOWN OF ADDISON, TEXAS

GREENHILL SCHOOL

By: Ron Whitehead
Ron Whitehead, City Manager

By: [Signature]

ATTEST:

Its: Director of Finance and Operations

By: C MORAN
Carmen Moran, City Secretary

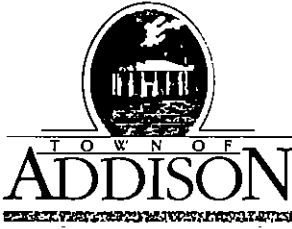

PUBLIC WORKS DEPARTMENT

Post Office Box 144 Addison, Texas 75001

(214) 450-2871

16801 Westgrove

May 8, 1996

Mr. Ken Piel
Greenhill School
14255 Midway Road
Dallas, Texas 75244-3698

Re: Traffic Signal on Spring Valley at Greenhill School Entrance

Dear Ken:

Attached are two copies of the Signal Participation Agreement for your execution. Council will approve the agreement at the May 14, 1996 Council meeting. It would be very helpful if you could return to me both copies of the agreement executed by you by Monday, May 13, 1996. I will be happy to come by and pick them up. I will return one copy of the agreement to you for your records after Ron has signed them.

Also attached is an invoice for \$30,500, which is approximately one-half of Greenhill's cost for the construction of the signal. The Town will invoice you for the remainder when the project is complete. If you have any questions please call me at 450-2879.

Sincerely,

David Nighswonger
Public Works Engineer

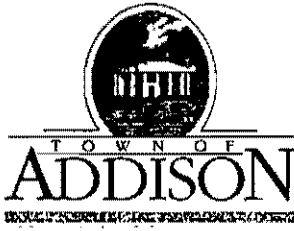

PUBLIC WORKS DEPARTMENT

Post Office Box 144 Addison, Texas 75001

(214) 450-2871

16801 Westgrove

MEMORANDUM

April 30, 1996

To: Ken Dippel
City Attorney

From: John R. Baumgartner, P.E. *JRB*
Director of Public Works

Re: Signal Participation Agreement

The Town of Addison & Greenhill School have agreed to construct a traffic signal at the intersection of Greenhill School and Spring Valley.

Greenhill School is paying for 75% of the construction cost and The Town of Addison is paying for 25% of the cost and providing project management/inspection.

The total project cost as bid is \$81,500. Greenhill school's share is \$61,125 or 75% of the actual construction cost.

They have generally agreed to pay \$30,500 now, and the remainder upon activation of the signal. I would propose payment is due 30 days from the date of the invoice.

I would like an infrastructure participation agreement between the Town of Addison and Greenhill School. They have dedicated easements as Greenhill School, by Ken Piel, Business Manager.

Please coordinate with David Nighswonger if you have any questions.



Engineers, Inc.

Grantham, Burge & Waldbauer

April 11, 1996

Mr. David J. Dillman
MFS
One Dallas Centre
350 North St. Paul, Suite 2950
Dallas, TX 75201

Re: Utility Coordination for Traffic Signal Installation
Spring Valley Road and Greenhill School

Dear Mr. Dillman:

Jack Hatchell & Associates has prepared plans on behalf of Greenhill School to install traffic signals at their south entrance off Spring Valley Road, approximately 1300 feet west of Midway Road. This project has been advertised for bid by the Town of Addison and the bid opening is scheduled for April 15, 1996. A construction schedule of 110 calendar days has been included in the bid opening to allow for the completion of the signal installation prior to school starting in August of this year.

The plan sheets for the signal installation have been enclosed for your review. These plan sheets do not reflect a right-turn lane which will be constructed into the south entrance by the School in the near future, nor do they reflect all of the underground and overhead utilities in the proposed construction area.

A recent field inspection of the site was conducted by our firm and it appeared that all of the underground utilities had been marked in preparation for the construction of the aforementioned right-turn lane. Based on the underground markings that appeared on the sidewalk, the proposed signal pole foundations on the north side of Spring Valley will need to be located behind the sidewalk. As a result, the proposed signal poles will be in conflict with the overhead utility lines. In addition, the overhead utilities on the south side of Spring Valley may also be in conflict with the proposed signal pole.

Please review the enclosed plans for potential conflicts with your facilities. I will be in contact within the next week to discuss these potential conflicts with you.

Very truly yours,

A handwritten signature in black ink, appearing to read 'BR', is written over a horizontal line.

Bruce R. Grantham, P.E.

Enclosure

cc: David Nighswonger
Jack Hatchell



Engineers, Inc.

Grantham, Burge & Waldbauer

April 11, 1996

Mr. Tim Beidelman
Southwestern Bell
275 N. Greenville
Richardson, TX 75081

Re: Utility Coordination for Traffic Signal Installation
Spring Valley Road and Greenhill School

Dear Mr. Beidelman:

Jack Hatchell & Associates has prepared plans on behalf of Greenhill School to install traffic signals at their south entrance off Spring Valley Road, approximately 1300 feet west of Midway Road. This project has been advertised for bid by the Town of Addison and the bid opening is scheduled for April 15, 1996. A construction schedule of 110 calendar days has been included in the bid opening to allow for the completion of the signal installation prior to school starting in August of this year.

The plan sheets for the signal installation have been enclosed for your review. These plan sheets do not reflect a right-turn lane which will be constructed into the south entrance by the School in the near future, nor do they reflect all of the underground and overhead utilities in the proposed construction area.

A recent field inspection of the site was conducted by our firm and it appeared that all of the underground utilities had been marked in preparation for the construction of the aforementioned right-turn lane. Based on the underground markings that appeared on the sidewalk, the proposed signal pole foundations on the north side of Spring Valley will need to be located behind the sidewalk. As a result, the proposed signal poles will be in conflict with the overhead utility lines. In addition, the overhead utilities on the south side of Spring Valley may also be in conflict with the proposed signal pole.

Please review the enclosed plans for potential conflicts with your facilities. I will be in contact within the next week to discuss these potential conflicts with you.

Very truly yours,

A handwritten signature in dark ink, appearing to read 'B. Grantham', is written over a horizontal line.

Bruce R. Grantham, P.E.

Enclosure

cc: David Nighswonger
Jack Hatchell



Grantham, Burge & Waldbauer

Engineers, Inc.

April 11, 1996

Mr. Rick Jaskula
TCI Cablevision
934 E. Centerville Rd.
Garland, TX 75234

Re: Utility Coordination for Traffic Signal Installation
Spring Valley Road and Greenhill School

Dear Mr. Jaskula:

Jack Hatchell & Associates has prepared plans on behalf of Greenhill School to install traffic signals at their south entrance off Spring Valley Road, approximately 1300 feet west of Midway Road. This project has been advertised for bid by the Town of Addison and the bid opening is scheduled for April 15, 1996. A construction schedule of 110 calendar days has been included in the bid opening to allow for the completion of the signal installation prior to school starting in August of this year.

The plan sheets for the signal installation have been enclosed for your review. These plan sheets do not reflect a right-turn lane which will be constructed into the south entrance by the School in the near future, nor do they reflect all of the underground and overhead utilities in the proposed construction area.

A recent field inspection of the site was conducted by our firm and it appeared that all of the underground utilities had been marked in preparation for the construction of the aforementioned right-turn lane. Based on the underground markings that appeared on the sidewalk, the proposed signal pole foundations on the north side of Spring Valley will need to be located behind the sidewalk. As a result, the proposed signal poles will be in conflict with the overhead utility lines. In addition, the overhead utilities on the south side of Spring Valley may also be in conflict with the proposed signal pole.

Please review the enclosed plans for potential conflicts with your facilities. I will be in contact within the next week to discuss these potential conflicts with you.

Very truly yours,

Bruce R. Grantham, P.E.

Enclosure

cc: David Nighswonger
Jack Hatchell



Engineers, Inc.

Grantham, Burge & Waldbauer

April 11, 1996

Mr. Howard Lewis
Lone Star Gas
1111 Jupiter Road, Suite 118E
Plano, TX 75074

Re: Utility Coordination for Traffic Signal Installation
Spring Valley Road and Greenhill School

Dear Mr. Lewis:

Jack Hatchell & Associates has prepared plans on behalf of Greenhill School to install traffic signals at their south entrance off Spring Valley Road, approximately 1300 feet west of Midway Road. This project has been advertised for bid by the Town of Addison and the bid opening is scheduled for April 15, 1996. A construction schedule of 110 calendar days has been included in the bid opening to allow for the completion of the signal installation prior to school starting in August of this year.

The plan sheets for the signal installation have been enclosed for your review. These plan sheets do not reflect a right-turn lane which will be constructed into the south entrance by the School in the near future, nor do they reflect all of the underground and overhead utilities in the proposed construction area.

A recent field inspection of the site was conducted by our firm and it appeared that all of the underground utilities had been marked in preparation for the construction of the aforementioned right-turn lane. Based on the underground markings that appeared on the sidewalk, the proposed signal pole foundations on the north side of Spring Valley will need to be located behind the sidewalk. As a result, the proposed signal poles will be in conflict with the overhead utility lines. In addition, the overhead utilities on the south side of Spring Valley may also be in conflict with the proposed signal pole.

Please review the enclosed plans for potential conflicts with your facilities. I will be in contact within the next week to discuss these potential conflicts with you.

Very truly yours,

A handwritten signature in dark ink, appearing to read 'BRG', is written over a horizontal line.

Bruce R. Grantham, P.E.

Enclosure

cc: David Nighswonger
Jack Hatchell



Engineers, Inc.

Grantham, Burge & Weldbauer

April 11, 1996

Mr. Joel Porter
TU Electric
14400 Josey Lane
Farmers Branch, TX 75234

Re: Utility Coordination for Traffic Signal Installation
Spring Valley Road and Greenhill School

Dear Mr. Porter:

Jack Hatchell & Associates has prepared plans on behalf of Greenhill School to install traffic signals at their south entrance off Spring Valley Road, approximately 1300 feet west of Midway Road. This project has been advertised for bid by the Town of Addison and the bid opening is scheduled for April 15, 1996. A construction schedule of 110 calendar days has been included in the bid opening to allow for the completion of the signal installation prior to school starting in August of this year.

The plan sheets for the signal installation have been enclosed for your review. These plan sheets do not reflect a right-turn lane which will be constructed into the south entrance by the School in the near future, nor do they reflect all of the underground and overhead utilities in the proposed construction area.

A recent field inspection of the site was conducted by our firm and it appeared that all of the underground utilities had been marked in preparation for the construction of the aforementioned right-turn lane. Based on the underground markings that appeared on the sidewalk, the proposed signal pole foundations on the north side of Spring Valley will need to be located behind the sidewalk. As a result, the proposed signal poles will be in conflict with the overhead utility lines. In addition, the overhead utilities on the south side of Spring Valley may also be in conflict with the proposed signal pole.

Please review the enclosed plans for potential conflicts with your facilities. I will be in contact within the next week to discuss these potential conflicts with you.

Very truly yours,

Bruce R. Grantham, P.E.

Enclosure

cc: David Nighswonger
Jack Hatchell

Facsimile Transmittal

Date: 4/8/96
Fax To: David Nighswonger
Fax #: 9316643
Re: Spring Valley/Greenhill School Signals
of Pages (including this sheet): 2

From: **GBW Engineers, Inc.**
1919 S. Shiloh Rd.
Suite 530, L.B. 27
Garland, Texas 75042
Tel (214) 840-1916
Fax (214) 840-2156

Fax From: Bruce Grantham

Comments:

Please review this utility coordination letter before I send a copy to each utility company.

Bruce

This message is intended only for the use of the individual or entity to which it is addressed, and may contain information that is privileged, confidential and exempt from disclosure under applicable law. If the reader of this message is not the intended recipient, or the employee or agent responsible for delivering the message to the intended recipient, you are hereby notified that any dissemination, distribution or copying of this communication is strictly prohibited. If you have received this communication in error, please notify us immediately by telephone, and return the original message to us at the above address via the U.S. Postal Service. Thank you.

April 8, 1996

Mr. Joel Porter
TU Electric
14400 Josey Lane
Farmers Branch, TX 75234

Re: Utility Coordination for Traffic Signal Installation
Spring Valley Road and Greenhill School

Dear Mr. Porter:

Jack Hatchell & Associates has prepared plans on behalf of Greenhill School to install traffic signals at their south entrance off Spring Valley Road, approximately 1300 feet west of Midway Road. This project has been advertised for bid by the Town of Addison and the bid opening is scheduled for April 15, 1996. A construction schedule of 110 calendar days has been included in the bid opening to allow for the completion of the signal installation prior to school starting in August of this year.

The plan sheets for the signal installation have been enclosed for your review. These plan sheets do not reflect a right-turn lane which will be constructed into the south entrance by the School in the near future, nor do they reflect all of the underground and overhead utilities in the proposed construction area.

A recent field inspection of the site was conducted by our firm and it appeared that all of the underground utilities had been marked in preparation for the construction of the aforementioned right-turn lane. Based on the underground markings that appeared on the sidewalk, the proposed signal pole foundations on the north side of Spring Valley will need to be located behind the sidewalk. As a result, the proposed signal poles will be in conflict with the overhead utility lines. In addition, the overhead utilities on the south side of Spring Valley may also be in conflict with the proposed signal pole.

Please review the enclosed plans for potential conflicts with your facilities. I will be in contact within the next week to discuss these potential conflicts with you.

Very truly yours,

Bruce R. Grantham, P.E.

cc: David Nighswonger
Jack Hatchell



April 8, 1996

Mr. John Baumgartner, P.E.
Director of Public Works
Town of Addison
16801 Westgrove Dr.
Addison, TX 75001

Re: Letter Agreement for Bidding Services
Spring Valley Road and Greenhill School Signalization

Dear Mr. Baumgartner:

GBW Engineers, Inc. (GBW) is pleased to present this letter agreement to provide bidding services for the traffic signal installation at Spring Valley Road and Greenhill School. The scope of services for this project is outlined below:

- Review the construction plans and bid documents for quantity consistency and conformance with Town of Addison policies and procedures.
- Inspect the site for field conditions which may impact the project quantities.
- Prepare the Advertisement for Bid and coordinate the bid schedule with Clyde Johnson.
- Arrange for the bid document revisions to be completed.
- Coordinate the required changes to the construction plans and bid documents with Jack Hatchell and Town of Addison staff.
- Arrange for the printing of the construction plans and bid documents.
- Contact the private utility companies in writing regarding potential conflicts with the project improvements.
- Prepare one addendum if required.
- Attend the bid opening and tabulate the bids.
- Check the low bidder's references and prepare a recommendation letter for the Town of Addison.

GBW proposes to provide the labor cost associated with this scope of work on an hourly basis for a fee not to exceed \$1,300 without prior written approval from the Town of Addison. Any reimburseables associated with this project, including printing, reproduction and secretarial support, will be invoiced at cost plus 10% handling.

Please execute this letter agreement if it meets with your approval and return a copy to our office.

Very truly yours,

Bruce R. Grantham, P.E.
President

APPROVED BY:

Town of Addison

\\addison\96-01\contract

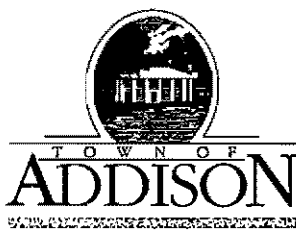

PUBLIC WORKS DEPARTMENT

Post Office Box 144 Addison, Texas 75001

(214) 450-2871

16801 Westgrove

February 13, 1996

Mr. Ray Gresset
M.A. Block Investment
14901 Quorum Drive
Addison, Texas 75240

Re: Greenhill School/Spring Valley Traffic Signal

Dear Mr. Gresset:

The Town of Addison and Greenhill School are working together to place a traffic signal at the entrance to Greenhill School and Spring Valley.

The estimated construction cost for this signal is \$100,000. The Town has committed to paying for 25% of the construction cost, performing all construction management/inspection, and funding all long term operational/maintenance costs.

At this time, Greenhill School is funding the engineering, 75% of the construction cost and providing the necessary easements for the controller and interconnect cable.

Our current schedule for the project calls for a bid opening in late March with a contract award on April 9, pending the receipt of Greenhill's portion of construction. It is our goal to complete the project prior to the start of school in August.

Please call me if you have any questions, or need additional information.

Sincerely,

John R. Baumgartner, P.E.
Director of Public Works

cc: David Nighswonger
Ken Piel

INVOICE NO. 1

For professional transportation engineering services rendered in connection with the investigation and preparation of temporary traffic signal timing plans on Midway Road at Greenhill School.

Staff

Jack Hatchell 2.75 hours @ \$ 75.00 per hour \$ 206.25

Direct Expenses

Traffic Counts (Metrocount) 118.70

Total Amount Due This Invoice \$ 324.95

Please make check payable to Jack Hatchell and remit to address below.

Jack Hatchell
P.O. Box 260119
Plano, Texas 75026-0119

Thank you.



METROCOUNT

Traffic Data Collection

INVOICE

CLIENT JACK HATCHELL and ASSOCIATES

P O Box 260119

Plano, Texas 75026-0119

DATE September 27, 1995

INVOICE NO. 18-02

REMIT TO:

METROCOUNT

3800 Beaumont Lane
Plano, Texas 75023

(214) 618-0663

Payment is due 30 days from
date of invoice. After 60 days,
a late charge of 5% per month
will be added.

For traffic data collected at Midway & Greenhill School.

PERSONNEL

Project Manager	.5 hrs	\$ 12.50
Analyst	.5 hrs	10.00
Field Technician	8.0 hrs	83.20

DIRECT EXPENSES

Mileage	52 miles	<u>13.00</u>
---------	----------	--------------

TOTAL AMOUNT DUE		<u>\$118.70</u>
------------------	--	-----------------

Thank you,
T. Hope Higinbotham
T. Hope Higinbotham
METROCOUNT

*Paid
11/5/95*

BEFORE COMPLETING THIS FORM, PLEASE CHECK VENDOR FILE FOR ALL POSSIBILITIES ON VENDOR NAME. PLEASE FILL IN THE REQUIRED INFORMATION AND SEND TO PURCHASING BY 5:00 PM FOR NEXT DAY PROCESSING. BEFORE MAKING A REQUEST BY PHONE, PLEASE CHECK PAGE 30 OF THE PURCHASING MANUAL.

REASON FOR REQUEST (Please circle)		INTERNAL INFORMATION	
<input checked="" type="radio"/> *New Vendor*	<input type="radio"/> Telephone Change	Requestor's Name	David Nighswonger
<input type="radio"/> Name Change	<input type="radio"/> Fax Change	Department	Public Works
<input type="radio"/> Address Change	<input type="radio"/> Contact Change	Date	2/6/96

*If new vendor, please state reason for adding vendor instead of using existing vendor. Engineering Services on Midway Road Drainage Project

REQUIRED INFORMATION

COMPANY NAME	<u>Jack Hatchell & Associates</u>		
MAILING ADDRESS	<u>P.O. Box 260119</u>		
CITY, STATE, ZIP	<u>Plano, Texas 75026-0119</u>		
TELEPHONE	<u>424-1368</u>	FAX#	
TAX ID#		SS#(Individual)	<u>464-48-8959</u>

<u>Billing/Additional Information (if different from above)</u>	
Contact Name	
Company Name	
Company Address	
City, State, Zip	
Telephone	Fax#

PURCHASING INFORMATION	
Vendor Number	
Date Entered	
Initials	

JACK HATCHELL & ASSOCIATES
CONSULTING ENGINEERING

P. O. Box 260119
Plano, Texas 75026-0119
(214) 424-1368

January 24, 1996

Mr. David C. Nighswonger, P.E.
Engineering
Town of Addison
P.O. Box 144
Addison, Texas 75001

Dear Mr. Nighswonger:

Please find enclosed Invoice No. 1 for professional transportation engineering services rendered in connection with the construction of the storm drainage system on Midway Road. This invoice includes traffic counts obtained at the intersection of Midway Road and Greenhill School and investigation of temporary signal timing plans for construction of the crossing of Greenhill School. We were indeed fortunate that the signal timing did not have to be changed because of the construction of the crossing during the school Christmas break.

If you find this invoice to be in order, I will appreciate receiving payment in the amount of \$ 324.95.

Thank you and the Town of Addison for providing me the opportunity to provide these services. I have initiated similar work for the Proton crossing. Please do not hesitate to call if you have any questions or need additional information.

Sincerely,

Jack Hatchell, P.E.

MEMORANDUM

To: David Nighswonger, P.E.
Town of Addison

From; Jack Hatchell, P.E.

Date: January 24, 1996

David -

Please find attached the Project Manual for the Spring Valley Road and Greenhill School traffic signal. I have also included a disk that contains the front portions of the Project Manual (all items except the technical specifications) in ASCII format and in professional write.

Thank you and Charles for your review of the plans and specifications and for your patience.

Please do not hesitate to call me if you have any questions or need additional information.

I N V O I C E

TO: TOWN OF ADDISON
P.O. BOX 144
ADDISON TX 75001

INVOICE NO. 00052741
INVOICE DATE 09/25/95
BUSINESS OFFICE: 51455000
REFERENCE NUM: 191131

REMIT TO:
TU ELECTRIC
P. O. BOX 111
DALLAS, TEXAS 75221-0111
ATTN: GENERAL ACCOUNTING

ACCOUNT REPRESENTATIVE: GREG HILTON
TERMS: DUE UPON RECEIPT

TEL NO. (214) 323-8928

DESCRIPTION:
RELOCATION OF OVERHEAD DISTRIBUTION FACILITIES FOR THE
MIDWAY ROAD DRAINAGE IMPROVEMENT PROJECT.

***** INVOICE TOTAL *****	2,094.00
**** CURRENT BALANCE ****	2,094.00

AGREEMENT

STATE OF TEXAS

COUNTY OF DALLAS

THIS AGREEMENT is made and entered into this 5TH day of SEPTEMBER, 1995, by and between the Town of Addison, of the County of Dallas and State of Texas, acting through its City Manager, duly authorized so to do, Party of the First Part, hereinafter termed the OWNER, and Scava Limited Partnership, of the City of Mesquite, County of Dallas, State of Texas, Party of the Second Part, hereinafter termed CONTRACTOR.

WITNESSETH: That for and in consideration of the payment and agreement hereinafter mentioned, to be made and performed by the OWNER, the said CONTRACTOR hereby agrees with the said OWNER to commence and complete construction of certain improvements as follows:

Midway Road Drainage Improvements from Greenhill Drive to T.U. Electric R.O.W.

and all extra work in connection therewith, under the terms as stated in the General and Specific Conditions of the AGREEMENT; and at his own proper cost and expense to furnish all the materials, supplies, machinery, equipment, tools, superintendence, labor, insurance and other accessories and services necessary to complete the said construction, in accordance with the conditions and prices stated in the Proposal attached hereto and in accordance with the Advertisement for Bids, Instructions to Bidders, General Provisions, Special Provisions, Plans, and other drawings and printed or written explanatory matter thereof, and the Technical Specifications and Addenda thereto, as prepared by the OWNER, each of which has been identified by the endorsement of the CONTRACTOR and the OWNER thereon, together with the CONTRACTOR's written Proposal and the General Provisions, all of which are made a part hereof and collectively evidence and constitute the entire AGREEMENT.

The CONTRACTOR hereby agrees to commence work within five (5) calendar days after the date of written notice to do so shall have been given to him, and to substantially complete the work within 145 calendar days after he commences work, and to totally complete the work in 165 calendar days after he commences work, subject to such extensions of time as are provided by the General Provisions.

The OWNER agrees to pay the CONTRACTOR \$941,486.50 in current funds for the performance of the Contract in accordance with the Proposal submitted thereof, subject to additions and deductions, as provided in the General Provisions, and to make payments of account thereof as provided therein.

IN WITNESS WHEREOF, the parties of these presents have executed this AGREEMENT in the year and day first above written.

TOWN OF ADDISON
(OWNER)

By: R. Whitehead
Ron Whitehead, City Manager

ATTEST:

C. MORAN
Carmen Moran, City Secretary

SCAVA LIMITED PARTNERSHIP
(CONTRACTOR)

By: Donald Haught
Donald Haught
Managing Partner

ATTEST:

By: Diane Benoit