

Addison Airport - Westside Pre-Construction
1998

CONUST

facsimile
TRANSMITTAL

to: Jim Pierce / Town of Addison
fax #: (972) 450-2879
re: Addison West Taxiway - Contractor's Proposed Phasing Plan
date: May 7, 1998
pages: 9, including this cover sheet.

Attached for your review and information is a copy of the letter submitted today by H. B. Zachry regarding their proposed phasing of the project (reducing from three phases to two by combining Phases 1 and 3). We will provide you with a recommendation regarding this proposal as soon as we complete our review.

cc: Karen Griffin

From the desk of...

Leslie Y. Saper, P.E.
Project Manager
URS GREINER, INC.
4100 Aron Center Blvd., Suite 108
Fort Worth, Texas 76155

(817) 545-0891
Fax: (817) 545-0534



H.B. Zachry Company

RECEIVED

May 2, 1998

MAY - 7 1998

FIELD OFFICE ADDRESS:

Ms. Leslie V. Sagar, P.E.
URS Greiner, Inc.
4100 Amon Carter Blvd., Ste. 108
Fort Worth, Texas 76155
RE: Addison West Taxiway

GREINER, INC.
FORT WORTH, TEXAS

HBZ Letter ATX 102

Dear Ms. Sagar,

As you know, we have been exploring alternatives to the plan phasing that would consolidate Stage 1 and Stage 3. In response to your fax of April 27, 1998 that concerns the same, we have the following comments:

- 1.) Runway Displacement - We agree that the displaced threshold should revert to the original location as soon as Taxiway C work is complete. We would propose to coordinate all activities during Stage 1 so that the duration of the displacement would be minimized while still maintaining the project schedule.
- 2.) Demarcation Between Stage 1 and Stage 2 on Taxiway C - The demarcation line should correspond to the location of an expansion joint, Joint Type B.
- 3.) Aircraft Access During Stage 1 - We intend to perform the Stage 1 work on Taxiway E either during the weekend period, as originally required on the plans, or during a nighttime runway shutdown as currently being proposed by AATI. We intend to provide a temporary connection between Taxilane 9 and 10 for access as shown on the plans.
- 4.) Aircraft Access During Stage 2 - It appears that a minimum 30 ft route width as shown on plan Sheet 5 and a maximum 2% profile for that route are achievable. We agree that it may be necessary to add additional paving at the transition from Taxiway B to Taxiway C.

We have attached information concerning this proposal for your review and approval.

In addition, we feel this proposal is in the best interest of all involved parties since it will reduce construction time by at least a week. We therefore request the owner's participation in sharing with us any material (asphaltic concrete, etc.), labor, and equipment costs associated with Item 4 above.

Your consideration of this request is appreciated.

Sincerely,

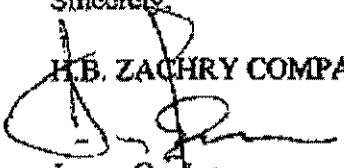
A handwritten signature in black ink, appearing to read 'James Gardner', is written over the typed name and company name.

H.B. ZACHRY COMPANY

James Gardner
Project Manager

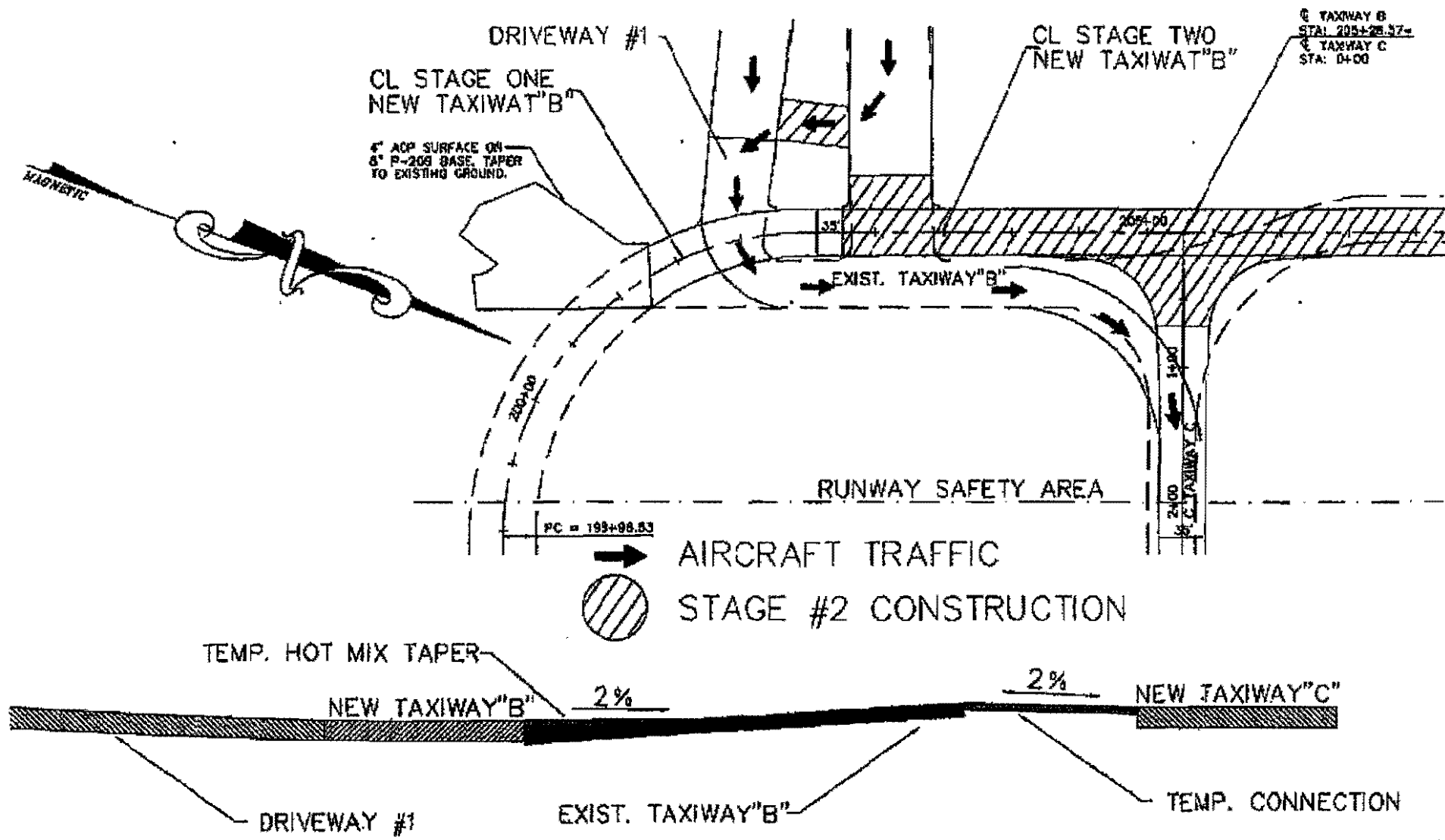

CL TAXIWAY B
 STA: 205+28.37-
 TAXIWAY C
 STA: 0+00

MAY-07-1998 17:50 FROM GREINER INC. 113 TO ADDISON/JIM P. P.04/09

facsimile

TRANSMITTAL

to: Jim Gardner / H. B. Zachry
fax #: (972) 267-0435
re: Addison West Taxiway - Proposed Phasing Modifications
date: April 27, 1998
pages: 5, including this cover sheet

In response to your request last Thursday that we perform a preliminary review of proposed phasing modifications to the West Taxiway project at Addison Airport, URS Greiner and AATI have reviewed the sketches you provided (attached). Based on our preliminary review, we are of the opinion that the proposed phasing changes can be accomplished provided that you meet the following requirements:

- 1) **Runway Displacement** - During Stage 1, the displacement of the runway threshold for the reconstruction of Taxiway C must be limited to the time necessary for the Taxiway C work to be accomplished (i.e. there is no need to displace the runway threshold for the entire duration of Stage 1). That is, once the threshold is displaced, the work on Taxiway C within the Runway Safety Area must begin and be completed promptly. When completed, the threshold will revert back to the runway end, even though there may be other components of Stage 1 still underway.
- 2) **Demarcation Between Stage 1 and Stage 2 on Taxiway C** - The demarcation line between Stage 1 and Stage 2 on Taxiway C needs to be located at Station 0+70 on Taxiway C, which will be the location of an expansion joint. See Sheet 20 of the plans for location of Joint Type B.
- 3) **Aircraft Access During Stage 1** - It is our understanding that you intend to perform the Stage 1 work on Taxiway E during night-time operations and that throughout Stage 1 aircraft will be able to access the east side via Taxiway E. We have also assumed that you will be providing the temporary connection between Taxiway 9 and 10 depicted on Sheet 5 of the plans so that aircraft will still be able to have ingress and egress to Building No. 92.
- 4) **Aircraft Access During Stage 2** - It is our understanding that during Stage 2 the aircraft will access the east side via the existing Taxiway B and Taxiway C. Since the aircraft must transition from new Taxiway B pavement to existing Taxiway B pavement and then to new Taxiway C pavement, the Contractor must ensure a minimum route width of 35 ft, and that the maximum profile along the route does not exceed 2%. In addition, temporary striping should be placed to help guide the pilots.

By having the demarcation line between Stage 1 and Stage 2 at the expansion joint location (Station 0+70), it may be necessary for the Contractor to add additional paving at the transition from the existing Taxiway B to the new Taxiway C pavement to achieve the 35 ft. width.

From the desk of,
Leslie V. Sager, P.E.
Project Manager
URS GREINER, INC.
4100 Arnon Center Blvd., Suite 108
Fort Worth, Texas 76159
(817) 545-0301
Fax: (817) 545-0534

5) Contractor's Haul Road Parallel to Taxiway B - The sketches you provided for Stages 1 and 2 depict construction traffic parallel to Taxiway. We have a concern that there may not be sufficient room on Airport property, particularly in the vicinity of the Taxiway 1-2 crossover. Please review the proposed route relative to the existing fence location so that the route is within the Airport property line.

Please let me know if you have any questions regarding our preliminary review of the proposed phasing modifications. We will need to see a more detailed phasing plan which encompasses the entire project before a final approval can be made.

Ustic Sager

cc:

Jim Pierce - Town of Addison

Zane Ryan - AATI

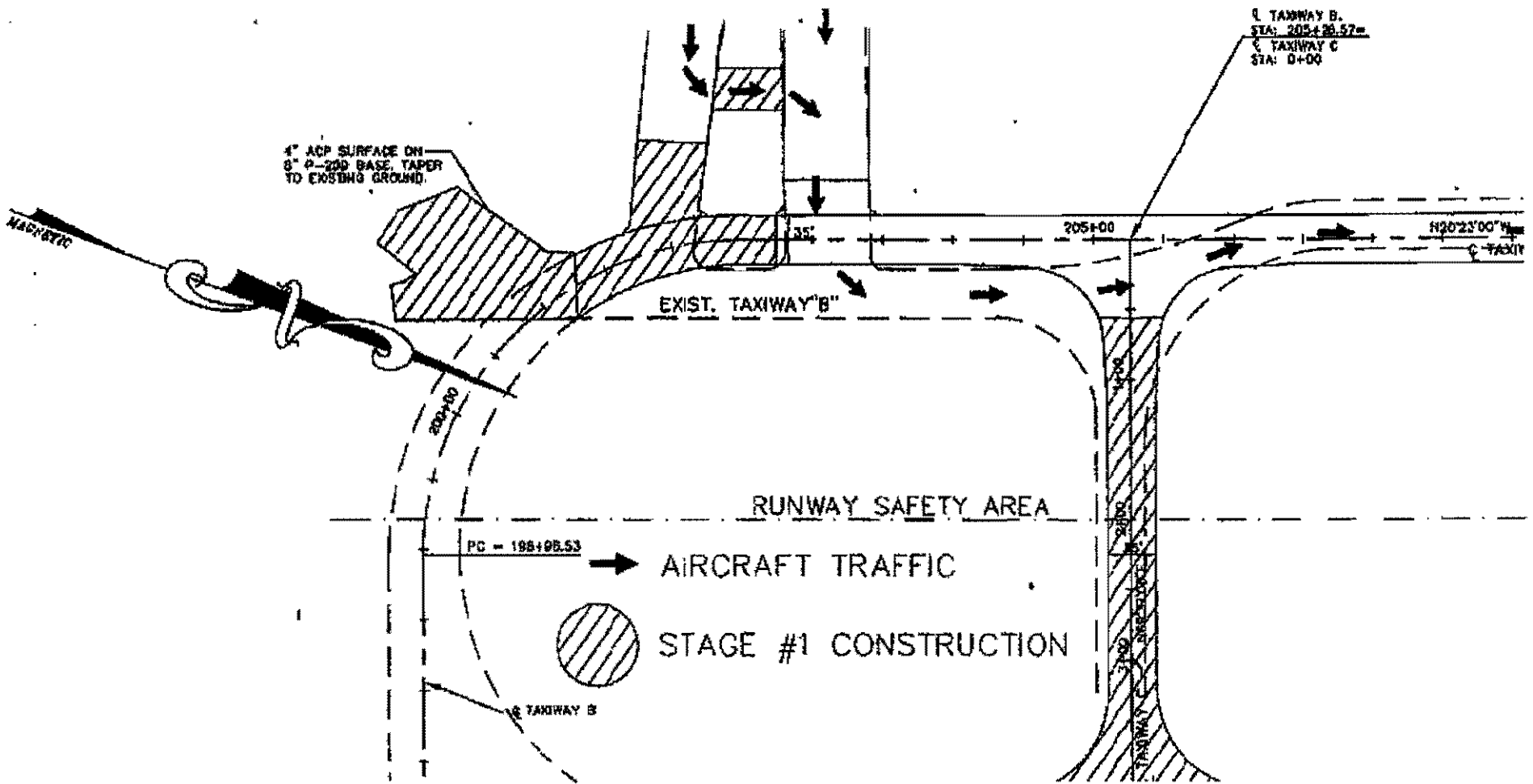

MAY-07-1998 17:51 FROM GREINER INC. 113 TO ADDISON/JIM P. P.08/09

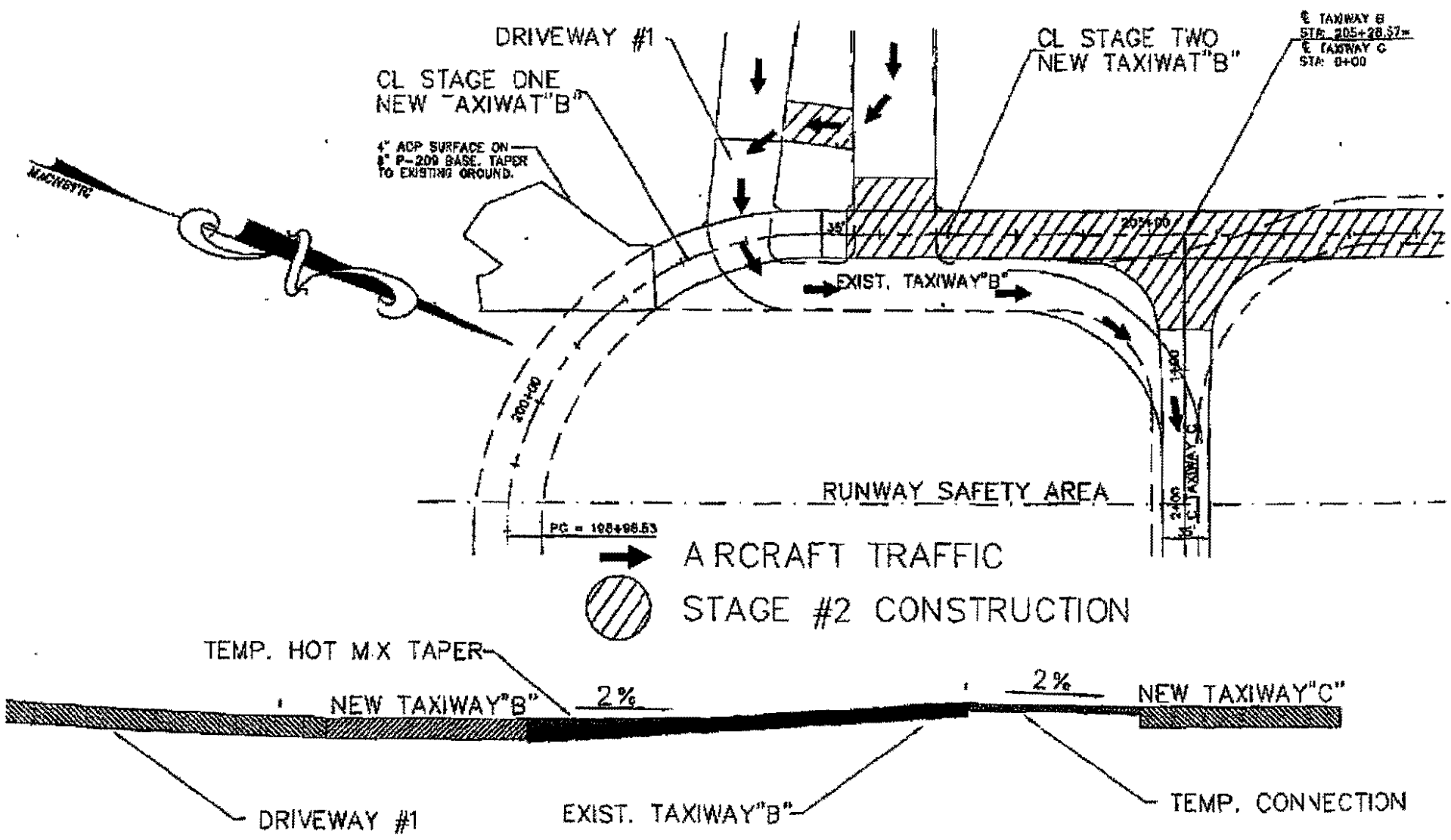

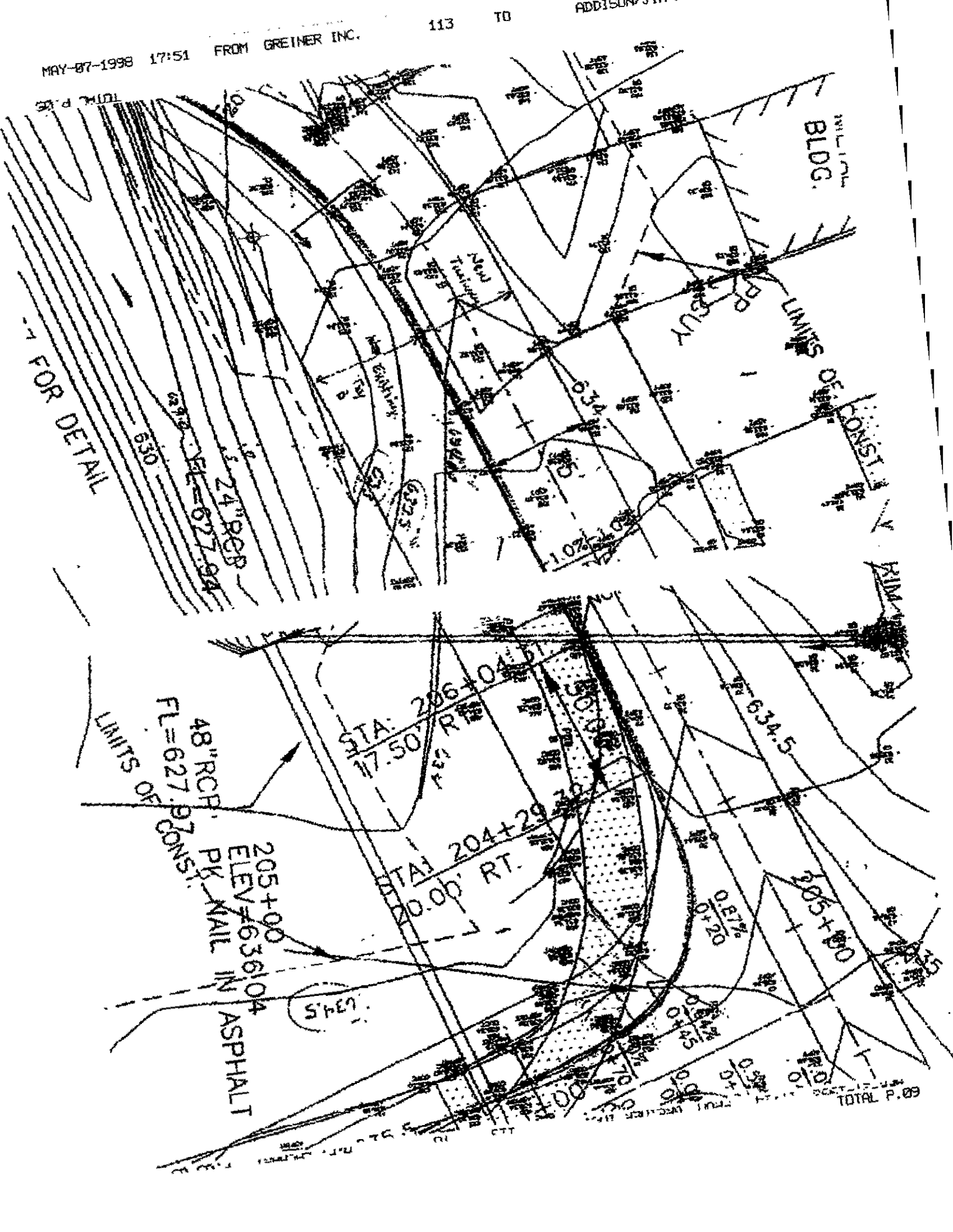

WILLIAM BLDG.

LIMITS OF CONSTRUCTION

KIM

FOR DETAIL

630

24" RCB
ELEV=627.94

STA: 206+04.5
17.50' RT.

634.5

LIMITS OF CONSTRUCTION
48" RCB
FL=627.97

205+00
ELEV=636.04
PK. NAIL IN ASPHALT

STA: 204+29
20.00' RT.

205+00

facsimile
TRANSMITTAL

to: Jim Gardner / H. B. Zachry
Jim Pierce / Town of Addison
Zane Ryan / AATI
Julian Wise / Wise Contractors-Consultants

fax #:

re: Draft Meeting Minutes from May 7, 1998 Construction Progress Meeting

date: May 13, 1998

pages: 5, including this cover sheet.

Attached for your review and comment are the Draft Meeting Minutes from the May 7, 1998 Construction Progress Meeting for the Addison West Taxiway and Connectors project. Please distribute these draft minutes to the other representatives from your organization which attended the meeting.

Please provide any comments/revisions to these minutes at our next meeting scheduled on May 14, 1998.

Leslie Sagar

Cable excavation, "protection" was discussed.

From the desk of...

Leslie V. Sagar, P.E.
Project Manager
URS GREINER, INC.
4100 Arnon Carter Blvd., Suite 108
Fort Worth, Texas 76155

(817) 545-0891
Fax: (817) 545-0534

URS Greiner

Project No. E708024.81

ADDISON AIRPORT
Construct West Side Taxiway and Drainage Improvements
Construction Progress Meeting No. 3

Draft Minutes of Meeting
May 7, 1998

ATTENDEES: See attached Attendance List

1. Distribution of Revised Meeting Minutes from the April 23, 1998 Meeting
Leslie Sagar distributed the revised minutes. There were no further comments.
2. Comments on Meeting Minutes from the April 30, 1998 Meeting
Draft Minutes were faxed to meeting attendees on May 4, 1998. There were no comments on the meeting minutes.
3. Project Schedule
Ms. Sagar advised that the Contractor had submitted a schedule on May 1, 1998; however, the schedule assumed two construction phases instead of three as per the contract documents. Ms. Sagar requested that the Contractor submit a project schedule which conforms with the contract documents. Jim Gardner stated that they would submit one by May 8, 1988.

Ms. Sagar asked for the 2-week schedule of activities. The Contractor did not have one prepared for the meeting. Ms. Sagar advised that the Contractor needs to provide a 2-week schedule at each Construction Progress Meeting so that everyone will have a clear understanding of the Contractor's work activities during that period and so that AATI can properly advise tenants in advance of uncoming work activities.

In lieu of a 2-week schedule, the Contractor's project schedule based on two phases was reviewed and the Phase 1 work activities were discussed. The Contractor was advised by Ms. Sagar that the work activities related to Phase 3 could not proceed until the Contractor formally submitted a request to alter the phasing plan and a Change Order is processed. Jim Gardner then submitted a letter dated May 2, 1998 requesting a change to the phasing plan. Ms. Sagar stated that it would be reviewed.

4. Status of Cost Proposals from Contractor Regarding Modification to Runway Closure Period for Taxiways E and F
Mr. Gardner submitted a letter dated May 5, 1998 with cost proposals for accomplishing work in one weekend, and also during multiple nights, that was to be performed in two weekends. Ms. Sagar stated that it would be reviewed.
5. Status of Permits
Ms. Sagar stated that she was aware that the Contractor had submitted an NOI to EPA, but she asked if the Contractor had obtained the Building Permit from the Town of Addison and the various

ADDISON AIRPORT

Construct West Side Taxiway and Drainage Improvements

Construction Progress Meeting Minutes – April 30, 1998

Page 2

- licenses required as discussed in the April 30, 1998 meeting. Mr. Gardner stated that they had not yet obtained the Building Permit or the licenses.

6. Submittals by Contractor

Ms. Sagar stated that the Contractor had submitted some information regarding the Quality Control Program but that in lieu of submitting each piece individually, the Contractor should combine the various components into one submittal document. Jim Gardner stated that they would do so.

Ms. Sagar reminded the Contractor that they needed to submit information previously requested regarding their DBE subcontractors.

Ms. Sagar distributed a summary log of the shop drawing and other submittals received as of May 6, 1997 from the Contractor and discussed the status of the submittals as well as some of the general review comments. Jim Pierce requested that all anticipated submittals be included on the log.

7. Requests for Information (RFI's)

Ms. Sagar distributed a log of the RFI's received as of May 6, 1998 from the Contractor. Regarding RFI No. 101 pertaining to the request for installation/use of an access gate at the north end of the project site, Ms. Sagar stated that a written response was forthcoming and that permission would be granted provided that the Contractor be responsible for maintaining the existing underground cables through a period extending 6 months beyond the end of the construction project. After discussion which led to the understanding of a concern that the direct buried cables need to be protected from "slicing" caused by heavy truck traffic on the surface, it was agreed that the Contractor would only be responsible for maintaining the cables through the end of the project provided that he adequately "bridge over" the cables.

Regarding RFI No. 102 pertaining to the electrical load calculations and data on the existing lighting system, Ms. Sagar advised that a written response would be forthcoming and was expected the next day by the electrical engineer responsible for the electrical design.

Wayne Crabtree stated that they would be submitting an RFI regarding the storm sewer in the vicinity of the temporary detour at Driveways 9-10 since construction of the detour will cut off storm drainage south of Driveway 9.

8. Coordination with FAA Tower Regarding Safety on the Airport During Construction

Ms. Sagar stated that the previous meeting which started at 8:30 a.m. with FAA personnel addressed the issue of the importance of Contractor coordination and communication with the Tower.

Zane Ryan advised the Contractor that helicopters are not on ground frequency and have been known to hover and land in the vicinity of the project area, and that the Contractor should be on the alert for helicopter activity.

9. Protection of Existing Underground Cables

Ms. Sagar stated that this would be a routine discussion item on the agenda each week as a reminder of the importance of avoiding any conflicts with existing underground cables.

ADDISON AIRPORT

Construct West Side Taxiway and Drainage Improvements

Construction Progress Meeting Minutes – April 30, 1998

Page 3

10. Notification of Utility Services or Other Facilities (GP-70-15)

Ms. Sagar advised the Contractor that General Provisions Section 70 requires that the Contractor provide written notification to utility companies/agencies that have underground cables in the project area, and that copies of the notices are to be submitted to the Engineer.

11. Other Items

- a. FAA Cables - Steven James (FAA) stated that the communications cables cannot be spliced, and if they are damaged the 25-pair control cables must be replaced. There are two runs: 1) Tower to Glide Slope, and 2) Glide Slope to Localizer. The depth of the buried cable ranges from 24" to 48" below grade.
- b. Job Trailers - The trailers are in place but are awaiting electrical power. Wayne Crabtree anticipated that they would have power by Monday, May 11.

12. Next Meeting Date

SIGN-IN SHEET

CONSTRUCTION PROGRESS MEETING

ADDISON AIRPORT
WEST TAXIWAY AND CONNECTORS WITH DRAINAGE IMPROVEMENTS
TXDOT PROJECT NO. 9248 ADDSN

Thursday, May 7, 1998
10:00 a.m.

8:30 am Meeting with FAA

	NAME	ORGANIZATION	TELEPHONE	FAX
1	Leslie Sagar	URS Greiner	(817) 545-0891	(817) 545-0534
2	Tex Schmidt	"	"	"
3	Larry Gardner	NATCA (ADS ATCT)	(972) 239-3725	
4	STEVEN JAMES	ADS SSLU (FAA)	(972) 239 4042	(972) 490 7324
5	DAVID A FREEMAN	ADS SSLU	(972) 239-4042	(972) 490-7324
6	Jim Pierce	Town of Addison	972-450-2879	... 2834
7	Rodney Soull	Addison Air Port	972-248-7733	
8	DANNY GLEASON	H.B. ZACHRY	972-267-0430	972-267-0435
9	ZANE RYAN	A.A.T.I.	972-248-7733	972-248-2416
10	ALVIN DEVANE	FAA ADS ATCT	972-239-3725	972-490-4338
11	Julian Wise	Wise Contrs. Consultants Inc	903 289 7404	same
12	Jim GARDNER	H.B. ZACHRY CO.	972-267-0430	972-267-0435
13	SKIP NORTON	H.B. ZACHRY Co.	972-267-0430	972-267-0435
14	Wayne Crabtree	H.B. Zachry Co.	972-267-0430	972-267-0435
15	Kurt Horn	Addison AIRPORT	248-7733 x 104	248-2416
16				
17				
18				
19				
20				

URS Greiner

Project No. E708024.81

ADDISON AIRPORT
Construct West Side Taxiway and Drainage Improvements
Construction Progress Meeting No. 2

Minutes of Meeting

April 30, 1998

ATTENDEES: See attached Attendance List

1. Review Meeting Minutes from the April 23, 1998 Meeting
Leslie Sagar stated that in the future, meeting minutes would be faxed to everyone ahead of time so they could review them in advance of the next Construction Progress Meeting. Jim Gardner stated that he had no comments, but that he would review the minutes again and advise if he did have comments. Kurt Horn stated that he had no comments.
2. Project Schedule
Jim Gardner stated that they are working on a project schedule and that they will deliver it to URS Greiner on Friday, May 1. He also stated that the schedule assumes two (2) weekend closures, in accordance with the current contract documents; however, the schedule assumes the work will be accomplished in two phases (instead of the three in the contract documents). Mr. Gardner stated that they will formalize their request for the work to be accomplished in two phases.
3. Status of Cost Proposals from Contractor Regarding Modification to Runway Closure Period for Taxiways E and F
Mr. Gardner stated that he planned to submit the cost proposals on Monday, May 4. He indicated that due to the cement shortage they were having difficulty getting prices on cement treated base, and he asked if they had to submit a proposal for this pavement option. Ms. Sagar advised that when the equivalent pavement sections were prepared by URS Greiner the intent had been for the Contractor to select the pavement section that would be the most time-efficient to construct and develop cost proposal for the night-time only and one weekend closure only scenarios.
4. Permits
Ms. Sagar advised the Contractor that a building permit would be required for the project (no fee), and that the building permit requires a Contractor's License (\$50), a Master Electrician's License (\$10), and a Journeyman Electrician's License (\$6), all of which are available at the Addison Service Center.

Jim Gardner stated that they have prepared the Notice of Intent (NOI), and that once it is signed by the President of their company it will be sent via registered mail to the EPA in Washington D.C. Mr. Gardner also stated that they will provide a copy of the Storm Water Pollution Prevention Plan (SWPPP) early next week (week of May 4).

ADDISON AIRPORT

Construct West Side Taxiway and Drainage Improvements

Construction Progress Meeting Minutes – April 30, 1998

Page 2

5. Status of Required Submittals by Contractor

Leslie Sagar asked about the status of the Quality Control Program, Submittals Schedule, Quality Control Testing Plan, Forms for Daily Inspection Reports and Daily Test Reports, and DBE Information to be provided by the Contractor. Mr. Gardner stated that they plan to submit these items on Monday, May 4.

6. Safety on the Airport During Construction

Leslie Sagar advised that FAA Order 5200.5B (*Airport Safety During FAA Funded Airport Construction and FAA Facilities Maintenance*) replaces the earlier version, FAA Order 5200.5A. A copy of FAA Order 5200.5B was previously mailed to and received by the Contractor, and Ms. Sagar provided a copy to Julian Wise. Jim Pierce also requested a copy.

7. Protection of Existing Underground Cables

Leslie Sagar reminded the Contractor that they are responsible for locating and staking all underground cables in the work area in advance of any excavation. Jim Gardner stated that they will rely on the FAA (Airways Facilities) and AATI to provide assistance with locating the cables. Zane Ryan stated that the Contractor needs to coordinate with Steve James of the FAA Airways Facilities, and requested that the Contractor utilize colored disks in lieu of stakes when marking cable locations.

8. Requests for Information (RFI's)

Jim Gardner stated that they would be faxing some RFI's to Ms. Sagar later that day.

9. Coordination with FAA

Since the FAA did not send anyone to the meeting as planned, Zane Ryan set up a meeting with the FAA for 9 a.m. on Tuesday, May 5 at the FAA Tower. The purpose of the meeting will be to discuss:

- Contractor Access to AOA
- Access Gates
- Ground Radios
 - Who must have them
 - How to use them
- Escorting of Delivery Vehicles within AOA

The meeting will be attended by representatives of AATI, H. B. Zachry, Leslie Sagar, Julian Wise, and Jim Pierce.

10. Notification of Tenants

Leslie Sagar stated that AATI will be responsible for notifying and coordinating with airport tenants affected by the West Taxiway project.

11. Lead Time for NOTAMS

Leslie Sagar stated that the contract documents require the Contractor to provide sufficient lead time for the issuance of NOTAM's. After discussion, it was agreed that a 48-hour lead time will be required.

ADDISON AIRPORT

Construct West Side Taxiway and Drainage Improvements

Construction Progress Meeting Minutes – April 30, 1998

Page 3

12. Other Items

- a. Kurt Horn requested that each Monday morning the Contractor and Julian Wise meet briefly with AATI regarding the weekly work activities.
- b. Jim Gardner briefly discussed the current cement shortage and the impacts it may have on obtaining price proposal from concrete suppliers.
- c. Joe LeWallen discussed the Contractor's Safety Program and that they have a Safety Manual, a Safety Handbook, and a Full-Time Safety Trailer that is used to provide monthly training sessions on active projects. Mr. LeWallen also stated that weekly safety meetings are held each Monday and that the Subcontractors attend these meetings and also receive training and advisories on work elements to be performed during the week. He also stated that they perform random mandatory drug testing on all employees.
- d. Leslie Sagar distributed half-size (11" x 17") sets of plans to the Contractor and Julian Wise, and also provided full size copies of Sheets 12 and 47 from the plans.
- e. Danny Gleason asked about the current electrical meter system in place in the Contractor's staging area. After discussion, it was determined that the Contractor should hook up to the existing secondary meeter.
- f. Zane Ryan stated that the Contractor should activate the Fire Department's electric gate (at Lindbergh Road) when a manned gated is not in operation to ensure the Fire Department has access to the AOA at all times in the event of an emergency.
- g. Wayne Crabtree stated that they planned to start setting up the field office trailers on Friday, May 1.

SIGN-IN SHEET

CONSTRUCTION PROGRESS MEETING

ADDISON AIRPORT
WEST TAXIWAY AND CONNECTORS WITH DRAINAGE IMPROVEMENTS
TXDOT PROJECT NO. 9248 ADDSN

Thursday, April 30, 1998
10:00 a.m.

NAME	ORGANIZATION	TELEPHONE	FAX
1 Leslie Sagar	URS Greiner	(817) 545-0891	(817) 545-0534
2 Julian Wise	Wise Contr Consultants Inc.	903-389-7404	same
3 Jim Hecce	Town of Addison	972-450-2879	- - 2834
4 Jim GARDNER	H. B. Zachry	972-267-0430	0435
5 Kurt Horn	ADDISON AIRPORT OF TEXAS, INC	248-7733 X104	248-2416
6 ZANE RYAN	Addison Airport	248-7733 X105	
7 Joe Lewallen	H. B. Zachry Co.	972-262-8848	972-262-5597
8 SKIP NORTON	H. B. Zachry Co.	972-446-0825	
9 Danny Gleason	H. B. Zachry Co.	972-267-0430	972-267-0435
10 Wayne Crabtree	H. B. Zachry Co.	972-267-0430	972-267-0435
11 Mafed Liman	H. B. Zachry Co.	(972) 267-0430	(972) 267-0435
12			
13			
14			
15			
16			
17			
18			
19			
20			

West Side @ FAA Tower

5-7-98

Al Devine

Larry Gardner Controller Rep.

Procedures for Ops on airport -

ILA

Localizer

Glideslope

200' from edge of runway is area
that you need permission to be in
Rod - Zanes assistant

Airport Movement Area - REQUIRES 2-WAY
COMMUNICATION
6AM - 12 midnight

Taxiways - Freq: 121.6 ground control
all movement except runway
"Admin Ground"

Who talk to

wh you are

where you are & what you want

(Freq. 126.0 is the Tower)

"Hold short" - if tower say this, you must say it back
to acknowledge

Do not ever get on the runway

Practical issues:

"Don't scare anybody"

Distance remaining signs create
a. don't scare anyone "line"

Emergency - can happen very fast - keep a
lookout @ all times

Always yield to an airplane

10 AM meeting - Agenda passed out

Need a schedule that reflects the
contract documents - 3 phases -

Will issue tomorrow -

Need a 2 week forward schedule
for each meeting -

There is

Phase 1 work ^{that} can proceed - See copy of
Schedule that has items X'ed out, that cannot.

Monday - Julian's trailer should be up & running
Schedule items (checks) will be done next 2 weeks.

Still need Permits -

Crushed Concrete as a substitute for crushed egg?

Storm Sewer Crosses | FAA cable & | AATE cable

FAA cables are under C, E & F - Caution req'd.

Discussed methods of protecting cable

ADDISON AIRPORT

CONSTRUCT WEST TAXIWAY AND CONNECTORS WITH DRAINAGE IMPROVEMENTS
(SOUTH SEGMENT)
TXDOT PROJECT NO. 9248 ADDSN

CONSTRUCTION PROGRESS MEETING NO.3
MAY 7, 1998
AGENDA

1. Distribution of Revised Meeting Minutes from the April 23, 1998 Meeting ✓
2. Comments on Meeting Minutes from the April 30, 1998 Meeting ✓
3. Project Schedule ✓
4. Status of Cost Proposals from Contractor Regarding Modification to Runway Closure Period for Taxiways E and F ✓
5. Status of Permits ✓
6. Submittals by Contractor ✓
 - a. Quality Control Program - Submittal No. 106, received 4/30/98 ✓
 - b. Submittals Schedule - Submittal No. 101, received 4/30/98 ✓
 - c. Quality Control Testing Plan
 - d. Forms for Daily Inspection Reports and Daily Test Reports
 - e. DBE Information
 - f. Construction Submittals/Shop Drawings
7. Requests for Information (RFI's) *Access gate @ N. End -
Electrical Related issues -*
8. Coordination with FAA Tower Regarding Safety on the Airport During Construction ✓
9. Protection of Existing Underground Cables
10. *written* Notification of Utility Services or Other Facilities (GP-70-15)
11. Other Items
12. Next Meeting Date

*Helicopters are
not on ground control
frequency*

TEXAS DEPARTMENT OF TRANSPORTATION
WEEKLY AIRPORT CONSTRUCTION REPORT - COVER PAGE

Report No. _____

Notice To Proceed Date: _____

TxDOT Project No. _____

For the Week of _____ (Monday) thru _____ (Sunday)

Airport: _____

Sponsor: _____

Engineer: _____

Contractor: _____

Prepared by: _____ Date: _____

Title: _____ RPR Hours Charged This Week: _____

CONTRACT TIME: _____ (Calendar Days)

Number of Days Charged To Date: _____

Last Day Charged (Date): _____

Rough Estimate of Percent Completion to Date:

Anticipated Work By Contractor For Next Period:

Problem Areas/Other Comments:

List All Equipment On the Project, (In use or not)

TXDOT Instructions for filling out and maintaining daily diary

Equipment & Force	Location of Work Sta. To Sta.		PRIME CONTRACTOR	To	SUB/CONTRACTOR #1	To	SUB/CONTRACTOR #2	To	To	To
	Pick-Ups *	2	1	1						
Front End Loader	2		1							
Water Truck *	2									
Dump Truck (12yd)	4		1							
Pneumatic Roller	1									
Pad Foot Roller *	1									
Vibratory Roller	1									
Motor Grader (2G)	1		1							
Backhoe *	2		1							
Trencher			1							
* = In Use										
Skilled	3	1								
Intermediate	5	2	3							
Unskilled	3	1								
Supervisory	1		1							
Operations Started @ 7:00 AM			Operations Stopped @ 5:00 PM							
Weather CLEAR & COOL			34° @ 7:00 AM							
Remarks on Time Charges			49° @ 2:00 PM							
	Day	5104190								

Date 1-1-93 (Fri.)

Detailed Description of ALL Construction Activities For The Day.

Record Type & Quantity of Materials Delivered.

Note Tests Performed and Testing Lab That Performed Them.

List Problems and Instructions To The Contractor.

Record All Visitors to the Project.

Make ALL Entries In INK, Sign @ The Bottom of Each Page.

Fill Out One Page For EACH Day (Including Weekends & Holidays)

(RRPR - Hours)

Signature Your Signature Here or
after last entry if partial page.

SIGN-IN SHEET

CONSTRUCTION PROGRESS MEETING

ADDISON AIRPORT
WEST TAXIWAY AND CONNECTORS WITH DRAINAGE IMPROVEMENTS
TXDOT PROJECT NO. 9248 ADDSN

Thursday, May 7, 1998
10:00 a.m.

8:30 am Meeting with FAA

	NAME	ORGANIZATION	TELEPHONE	FAX
1	Leslie Sagar	URS Greiner	(817) 545-0891	(817) 545-0534
2	Tex Schmidt	"	"	"
3	Larry Gardner	NATCA (ADS ATCT)	(972) 239-3725	
4	STEVEN JAMES	ADS SSW (FAA)	(972) 239 4042	(972) 490 7324
5	DAVID A FREEMAN	ADS SSW	(972) 239-4042	(972) 490-7324
6	Jim Pierce	Town of Addison	972-450-2879	... 2834
7	Rodney South	Addison Air Port	972-248-7733	
8	DANNY GLEASON	H.B. ZACHRY	972-267-0430	972-267-0435
9	ZANE RYAN	AATI	972-248-7733	972-248-2416
10	ALVIN DEVANE	FAA ADS ATCT	972-239-3725	972-490-4338
11	Julian Wise	Wise Contrs. Consultants Inc	903 389 7404	same
12	JIM GARDNER	H.B. ZACHRY CO	972-267-0430	972-267-0435
13	SKIP NORTON	H.B. ZACHRY CO.	972-267-0430	972-267-0435
14	Wayne Crabtree	H.B. Zachry Co.	972-267 0430	972-267-0435
15	Kurt Horn			
16				
17				
18				
19				
20				

URS Greiner

Project No. E708024.81

ADDISON AIRPORT
Construct West Side Taxiway and Drainage Improvements
Construction Progress Meeting No. 2

Draft Minutes of Meeting

April 30, 1998

ATTENDEES: See attached Attendance List

1. Review Meeting Minutes from the April 23, 1998 Meeting
Leslie Sagar stated that in the future, meeting minutes would be faxed to everyone ahead of time so they could review them in advance of the next Construction Progress Meeting. Jim Gardner stated that he had no comments, but that he would review the minutes again and advise if he did have comments. Kurt Horn stated that he had no comments.
2. Project Schedule
Jim Gardner stated that they are working on a project schedule and that they will deliver it to URS Greiner on Friday, May 1. He also stated that the schedule assumes two (2) weekend closures, in accordance with the current contract documents; however, the schedule assumes the work will be accomplished in two phases (instead of the three in the contract documents). Mr. Gardner stated that they will formalize their request for the work to be accomplished in two phases.
3. Status of Cost Proposals from Contractor Regarding Modification to Runway Closure Period for Taxiways E and F
Mr. Gardner stated that he planned to submit the cost proposals on Monday, May 4. He indicated that due to the cement shortage they were having difficulty getting prices on cement treated base, and he asked if they had to submit a proposal for this pavement option. Ms. Sagar advised that when the equivalent pavement sections were prepared by URS Greiner the intent had been for the Contractor to select the pavement section that would be the most time-efficient to construct and develop cost proposal for the night-time only and one weekend closure only scenarios.
4. Permits
Ms. Sagar advised the Contractor that a building permit would be required for the project (no fee), and that the building permit requires a Contractor's License (\$50), a Master Electrician's License (\$10), and a Journeyman Electrician's License (\$6), all of which are available at the Addison Service Center.

Jim Gardner stated that they have prepared the Notice of Intent (NOI), and that once it is signed by the President of their company it will be sent via registered mail to the EPA in Washington D.C. Mr. Gardner also stated that they will provide a copy of the Storm Water Pollution Prevention Plan (SWPPP) early next week (week of May 4).

ADDISON AIRPORT

Construct West Side Taxiway and Drainage Improvements

Construction Progress Meeting Minutes – April 30, 1998

Page 2

5. Status of Required Submittals by Contractor

Leslie Sagar asked about the status of the Quality Control Program, Submittals Schedule, Quality Control Testing Plan, Forms for Daily Inspection Reports and Daily Test Reports, and DBE Information to be provided by the Contractor. Mr. Gardner stated that they plan to submit these items on Monday, May 4.

6. Safety on the Airport During Construction

Leslie Sagar advised that FAA Order 5200.5B (*Airport Safety During FAA Funded Airport Construction and FAA Facilities Maintenance*) replaces the earlier version, FAA Order 5200.5A. A copy of FAA Order 5200.5B was previously mailed to and received by the Contractor, and Ms. Sagar provided a copy to Julian Wise. Jim Pierce also requested a copy.

7. Protection of Existing Underground Cables

Leslie Sagar reminded the Contractor that they are responsible for locating and staking all underground cables in the work area in advance of any excavation. Jim Gardner stated that they will rely on the FAA (Airways Facilities) and AATI to provide assistance with locating the cables. Zane Ryan stated that the Contractor needs to coordinate with Steve James of the FAA Airways Facilities, and requested that the Contractor utilize colored disks in lieu of stakes when marking cable locations.

8. Requests for Information (RFI's)

Jim Gardner stated that they would be faxing some RFI's to Ms. Sagar later that day.

9. Coordination with FAA

Since the FAA did not send anyone to the meeting as planned, Zane Ryan set up a meeting with the FAA for 9 a.m. on Tuesday, May 5 at the FAA Tower. The purpose of the meeting will be to discuss:

- • Contractor Access to AOA
- • Access Gates
- • Ground Radios
 - Who must have them
 - How to use them
- • Escorting of Delivery Vehicles within AOA

The meeting will be attended by representatives of AATI, H. B. Zachry, Leslie Sagar, Julian Wise, and Jim Pierce.

10. Notification of Tenants

Leslie Sagar stated that AATI will be responsible for notifying and coordinating with airport tenants affected by the West Taxiway project.

11. Lead Time for NOTAMS

Leslie Sagar stated that the contract documents require the Contractor to provide sufficient lead time for the issuance of NOTAM's. After discussion, it was agreed that a 48-hour lead time will be required.

ADDISON AIRPORT

Construct West Side Taxiway and Drainage Improvements

Construction Progress Meeting Minutes – April 30, 1998

Page 3

12. Other Items

- a. Kurt Horn requested that each Monday morning the Contractor and Julian Wise meet briefly with AATI regarding the weekly work activities.
- b. Jim Gardner briefly discussed the current cement shortage and the impacts it may have on obtaining price proposal from concrete suppliers.
- c. Joe LeWallen discussed the Contractor's Safety Program and that they have a Safety Manual, a Safety Handbook, and a Full-Time Safety Trailer that is used to provide monthly training sessions on active projects. Mr. LeWallen also stated that weekly safety meetings are held each Monday and that the Subcontractors attend these meetings and also receive training and advisories on work elements to be performed during the week. He also stated that they perform random mandatory drug testing on all employees.
- d. Leslie Sagar distributed half-size (11" x 17") sets of plans to the Contractor and Julian Wise, and also provided full size copies of Sheets 12 and 47 from the plans.
- e. Danny Gleason asked about the current electrical meter system in place in the Contractor's staging area. After discussion, it was determined that the Contractor should hook up to the existing secondary meeter.
- f. Zane Ryan stated that the Contractor should activate the Fire Department's electric gate (at Lindbergh Road) when a manned gated is not in operation to ensure the Fire Department has access to the AOA at all times in the event of an emergency.
- g. Wayne Crabtree stated that they planned to start setting up the field office trailers on Friday, May 1.

-

SIGN-IN SHEET

CONSTRUCTION PROGRESS MEETING

ADDISON AIRPORT
WEST TAXIWAY AND CONNECTORS WITH DRAINAGE IMPROVEMENTS
TXDOT PROJECT NO. 9248 ADDSN

Thursday, April 30, 1998
10:00 a.m.

NAME	ORGANIZATION	TELEPHONE	FAX
1 Leslie Sagar	URS Greiner	(817) 545-0891	(817) 545-0534
2 Julian Wise	Wise Contr Consultants, Inc.	903-389-7404	same
3 Jim Herve	Town of Addison	972-450-2879	-- 2834
4 Jim Gardner	H.B. Zachry	972-267-0430	0435
5 Kurt Horn	Addison Airport of Texas, Inc	248-7733 x104	248-2416
6 Zane Ryan	Addison Airport	248-7733 x105	
7 Joe Lewallen	H.B. Zachry Co.	972-262-8848	972-262-5597
8 Skip Norton	H.B. Zachry Co.	972-446-0825	
9 Danny Gleason	H.B. Zachry Co.	972-267-0430	972-267-0435
10 Wayne Crabtree	H.B. Zachry Co.	972-267-0430	972-267-0435
11 Milt Limann	H.B. Zachry Co.	(972) 267-0430	(972) 267-0435
12			
13			
14			
15			
16			
17			
18			
19			
20			

ADDISON AIRPORT
Construct West Side Taxiway and Drainage Improvements
Construction Progress Meeting No. 1

Minutes of Meeting (Revised)
April 23, 1998

Reed 5-7-98

ATTENDEES: See attached Attendance List

1. Contractor's Notice to Proceed Date

In response to a letter dated April 21, 1998 from H. B. Zachry requesting to delay the Notice to Proceed (NTP) date until May 6, 1998, the Town of Addison provided a letter stating their approval of the revised NTP date.

2. Project Schedule Submittal

Leslie Sagar reminded the Contractor that by contract a schedule must be submitted within ten days of the NTP date. Jim Gardner indicated that they will be providing a schedule in accordance with the contract and which incorporates proposed work sequencing changes under discussion and review.

3. Modification to Runway Closure Period for Taxiways E and F

a. Equivalent Pavement Sections

Three different pavement sections faxed to Jim Gardner on April 22 for Taxiway F were discussed. Jim Gardner said they preferred Options 1 and 2, and Jim Pierce stated that the Town preferred Option 1. Jim Gardner indicated they normally would prefer Option 1 but the current cement shortage may create a problem.

b. Request for Cost Proposals

Leslie Sagar discussed the fax request made to Jim Gardner on April 22 for two cost proposals for Taxiway E and F construction during one (1) weekend closure (9 pm Fri. thru 6 am Mon.), and as night-time work (9 pm thru 6 am).

Jim Gardner stated that he would provide cost proposals for pavement Options 1 and 2 for both scenarios next week.

4. Permits

Leslie Sagar stated that the Contractor is responsible for obtaining all necessary permits prior to construction, including the preparation of an Erosion Control/Storm Water Pollution Prevention Plan and sending a Notice of Intent (NOI) form to the EPA.

Jim Gardner stated that they are working on the SWPPP and asked if the Town had any special permits that they needed to obtain. Jim Pierce stated that he would check the Town's permit requirements.

ADDISON AIRPORT

Construct West Side Taxiway and Drainage Improvements

Construction Progress Meeting Minutes – April 23, 1998

Page 2

5. Contractor's Quality Control Program

Leslie Sagar stated that the Contractor is required to submit a written Quality Control Program and to designate a Program Administrator and QC Technicians which must meet certain training and experience requirements specified in General Provisions Section 100. Jim Gardner acknowledged the requirement.

6. Submittals Schedule

Leslie Sagar stated that the Contractor is required to submit a detailed listing of all submittals (mix designs, materials certifications, shop drawings) for the project as specified in General Provisions Section 100. Jim Gardner acknowledged the requirement. Julian Wise advised the Contractor to turn in the submittals as soon as possible since some items have long lead times. Mr. Wise also said that material certifications must be submitted and approved in advance of materials being delivered to the site.

7. Quality Control Testing Plan

Leslie Sagar stated that the Contractor is required to submit a spreadsheet of project testing requirements as specified in General Provisions Section 100. Jim Gardner acknowledged the requirement.

8. Documentation / Quality Control Records

Leslie Sagar reminded the Contractor that the Contractor's forms for the Daily Inspection Report and the Daily Test Report must be reviewed and approved by the Engineer in advance of their use, as specified in General Provisions Section 100. Jim Gardner acknowledged the requirement.

9. Safety on the Airport During Construction

Leslie Sagar stated that the Contractor is required to comply with FAA Order 5200.5A - *Airport Safety During FAA Funded Airport Construction and FAA Facilities Maintenance* as specified in the Special Provisions. Ms. Sagar provided a copy of the document to Jim Gardner and Julian Wise, but stated that there may be a more current version and that she would check on it. Ms. Sagar advised the Contractor to review the FAA Order to let her know if they had any questions.

10. Protection of Existing Underground Cables

Leslie Sagar stated that the Contractor is required to locate and stake all underground cables in advance of construction as required by the Special Provisions, and to coordinate with FAA Airways Facilities for location of FAA cables. Ms. Sagar also stated that it was important for the Contractor to ensure that the equipment operators understand where the utilities are located and the importance of avoiding any cable breaks. Wayne Crabtree stated that H. B. Zachry has internal safety procedures to ensure that the equipment operators are knowledgeable about the area they will be working in each day.

Jim Gardner stated that H.B. Zachry would rely upon underground utility companies, the FAA and/or the Town of Addison for preliminary locations of utilities within the work area. Kurt Horn stated that someone with the FAA would assist in locating cables.

ADDISON AIRPORT

Construct West Side Taxiway and Drainage Improvements

Construction Progress Meeting Minutes – April 23, 1998

Page 3

11. Contractor's Requests for Information (RFI's)

Jim Gardner stated that they have some RFI's they will be submitting next week. Leslie Sagar stated that all RFI's should be submitted to Julian Wise, but until Julian Wise is located in a field office at the project site, RFI's should be faxed to Julian at the URS Greiner Fort Worth office.

12. Contractor Access to AOA

Leslie Sagar stated that the Contractor had requested the lock combinations to the access gates to the AOA. Kurt Horn stated that he would provide those to Jim Gardner by the end of the day.

Jim Gardner asked what the procedure should be for them obtaining access on the AOA and whether they would have to coordinate with AATI and the FAA every morning. Kurt Horn explained that the Contractor would have to be in communication with the FAA Tower when they want to access aircraft movement areas (active taxiways) and that he would coordinate with Al Devane, FAA Tower Chief at Addison, and ask him to attend the next Construction Progress Meeting on April 30.

13. DBE Information

Leslie Sagar provided a DBE information form to Jim Gardner which the Contractor needs to fill out with the contract dollar amount awarded to their DBE subcontractors. Ms. Sagar advised that at the end of the project the Contractor will be asked to provide the total amount paid to the DBE subcontractors. The forms are to be submitted to Ms. Sagar and she will forward them to Clyde Johnson, the Town's Purchasing Manager.

14. Other Items

Leslie Sagar advised that a "Test Strip" of the TxDOT Item 340 asphalt base would not be required. The "Test Strip" applies only to P-401 Bituminous Material which was for Alternate No. 2, not Alternate No. 1.

Everyone agreed that the next Construction Progress Meeting should be held on April 30 at 10:00am.

Jim Gardner asked about daily security procedures and the training AATI will provide, and the need for a wing-walker to guide pilots. Kurt Horn stated that he would arrange for a meeting with the FAA and the Contractor in which they would go over the procedures related to security and access to the AOA. Mr. Horn also stated that a wing-walker would be necessary to guide pilots at the Taxilane 1-2 cross-over.

Jim Gardner asked if the Engineer had a special Pay Request format. Leslie Sagar advised him to provide a format for her review.

Jim Gardner asked about working in the ILS critical area. Kurt Horn explained that in inclement weather (Instrument Flight Rule (IFR) conditions) during north flow operations the Contractor may not be able to work in the ILS critical area because the heavy equipment and vehicles could disrupt the glide slope and and localizer signal. Mr. Horn stated that he would invite the FAA Tower Chief

ADDISON AIRPORT

Construct West Side Taxiway and Drainage Improvements

Construction Progress Meeting Minutes – April 23, 1998

Page 4

- to the next meeting so that he can explain how the Contractor will need to coordinate with the FAA during IFR conditions.

cc: Attendance list

E78024.81
P:\DOCS\MEETINGS\MTG1.MIN

SIGN-IN SHEET

CONSTRUCTION PROGRESS MEETING

ADDISON AIRPORT
 WEST TAXIWAY AND CONNECTORS WITH DRAINAGE IMPROVEMENTS
 TXDOT PROJECT NO. 9248 ADDSN

Thursday, April 23, 1998
 10:00 a.m.

NAME	ORGANIZATION	TELEPHONE	FAX
1 Leslie Sagar	URS Greiner		
2 Julian Wise	Wise Contractors - Consultants		
3 Jim Pierce	Town of Addison		
4 Jim Gardner	HB Zachry		
5 Wayne Crabtree	"		
6 Danny Gleason	"		
7 Majed Limam	"		
8 Skip Norton	"		
9 Kurt Horn	AATI		
10			
11			
12			
13			
14			
15			
16			
17			
18			
19			
20			

ADDISON AIRPORT

CONSTRUCT WEST TAXIWAY AND CONNECTORS WITH DRAINAGE IMPROVEMENTS
(SOUTH SEGMENT)
TXDOT PROJECT NO. 9248 ADDSN

CONSTRUCTION PROGRESS MEETING NO.2

APRIL 30, 1998

AGENDA

- 1. Review Meeting Minutes from the April 23, 1998 Meeting
- 2. Project Schedule *In progress - 2 weekend closure - Ready May 1st
Based on 2 phases -*
- 3. Status of Cost Proposals from Contractor Regarding Modification to Runway Closure Period for Taxiways E and F *Probably have Monday -*
- 4. Permits *NOI in progress -*
- 5. Status of Required Submittals by Contractor
 - a. Quality Control Program
 - b. Submittals Schedule
 - c. Quality Control Testing Plan
 - d. Forms for Daily Inspection Reports and Daily Test Reports
 - e. DBE Information *Terra Mar*

5/7
 Thurs PM & Friday 5/8
 Kurt & Zane out of
 Pocket - Ed Morales
 will sit in

- 6. Safety on the Airport During Construction
 - a. FAA Order 5200.5B - Airport Safety During FAA Funded Airport Construction and FAA Facilities Maintenance

- 7. Protection of Existing Underground Cables *FAA has equipment & can find Steve James - FAA*
- 8. Requests for Information (RFI's)

- 9. Coordination with FAA
 - a. Contractor Access to AOA
 - b. Access Gates
 - c. Ground Radios
 - Who must have them
 - How to use them
 - d. Escorting of Delivery Vehicles within AOA
 - e. *operating within ILA*

Some will be faxed today

Wed is May 6th

- 10. Notification of Tenants
- 11. Lead Time for NOTAMS *Zane - AATI has a fax system to notify all Tenants - with a phone call-in line.*
- 12. Other Items *Can close evenings 9 + 6*

48 hours notice

↳ Kurt & Zashry meet every mon AM to discuss

Kurt will schedule for 9AM Tues @ Tower -

Closing or altering Length

No Sep permit for 26' Trailer plus gate monitor shack?

ADDISON AIRPORT
Construct West Side Taxiway and Drainage Improvements
Construction Progress Meeting No. 1

Minutes of Meeting
April 23, 1998

ATTENDEES: See attached Attendance List

1. Contractor's Notice to Proceed Date
In response to a letter dated April 21, 1998 from H. B. Zachry requesting to delay the Notice to Proceed (NTP) date until May 6, 1998, the Town of Addison provided a letter stating their approval of the revised NTP date.
2. Project Schedule Submittal
Leslie Sagar reminded the Contractor that by contract a schedule must be submitted within ten days of the NTP date. Jim Gardner indicated that they will be providing a schedule in accordance with the contract and which incorporates proposed work sequencing changes under discussion and review.
3. Modification to Runway Closure Period for Taxiways E and F
 - a. Equivalent Pavement Sections
Three different pavement sections faxed to Jim Gardner on April 22 for Taxiway F were discussed. Jim Gardner said they preferred Options 1 and 2, and Jim Pierce stated that the Town preferred Option 1. Jim Gardner indicated they normally would prefer Option 1 but the current cement shortage may create a problem.
 - b. Request for Cost Proposals
Leslie Sagar discussed the fax request made to Jim Gardner on April 22 for two cost proposals for Taxiway E and F construction during one (1) weekend closure (9 pm Fri. thru 6 am Mon.), and as night-time work (9 pm thru 6 am).

Jim Gardner stated that he would provide cost proposals for pavement Options 1 and 2 for both scenarios next week.
4. Permits
Leslie Sagar stated that the Contractor is responsible for obtaining all necessary permits prior to construction, including the preparation of an Erosion Control/Storm Water Pollution Prevention Plan and sending a Notice of Intent (NOI) form to the EPA.

Jim Gardner stated that they are working on the SWPPP and asked if the Town had any special permits that they needed to obtain. Jim Pierce stated that he would check the Town's permit requirements. ✓
5. Contractor's Quality Control Program

ADDISON AIRPORT

Construct West Side Taxiway and Drainage Improvements

Construction Progress Meeting Minutes – April 23, 1998

Page 2

Leslie Sagar stated that the Contractor is required to submit a written Quality Control Program and to designate a Program Administrator and QC Technicians which must meet certain training and experience requirements specified in General Provisions Section 100. Jim Gardner acknowledged the requirement.

6. Submittals Schedule

Leslie Sagar stated that the Contractor is required to submit a detailed listing of all submittals (mix designs, materials certifications, shop drawings) for the project as specified in General Provisions Section 100. Jim Gardner acknowledged the requirement. Julian Wise advised the Contractor to turn in the submittals as soon as possible since some items have long lead times. Mr. Wise also said that material certifications must be submitted and approved in advance of materials being delivered to the site.

7. Quality Control Testing Plan

Leslie Sagar stated that the Contractor is required to submit a spreadsheet of project testing requirements as specified in General Provisions Section 100. Jim Gardner acknowledged the requirement.

8. Documentation / Quality Control Records

Leslie Sagar reminded the Contractor that the Contractor's forms for the Daily Inspection Report and the Daily Test Report must be reviewed and approved by the Engineer in advance of their use, as specified in General Provisions Section 100. Jim Gardner acknowledged the requirement.

9. Safety on the Airport During Construction

Leslie Sagar stated that the Contractor is required to comply with FAA Order 5200.5A^B - *Airport Safety During FAA Funded Airport Construction and FAA Facilities Maintenance* as specified in the Special Provisions. Ms. Sagar provided a copy of the document to Jim Gardner and Julian Wise, but stated that there may be a more current version and that she would check on it. Ms. Sagar advised the Contractor to review the FAA Order to let her know if they had any questions.

10. Protection of Existing Underground Cables

Leslie Sagar stated that the Contractor is required to locate and stake all underground cables in advance of construction as required by the Special Provisions, and to coordinate with FAA Airway Facilities for location of FAA cables. Ms. Sagar also stated that it was important for the Contractor to ensure that the equipment operators understand where the utilities are located and the importance of avoiding any cable breaks. Wayne Crabtree stated that H. B. Zachry has internal safety procedures to ensure that the equipment operators are knowledgeable about the area they will be working in each day.

11. Contractor's Requests for Information (RFI's)

Jim Gardner stated that they have some RFI's they will be submitting next week. Leslie Sagar stated that all RFI's should be submitted to Julian Wise, but until Julian Wise is located in a field office at the project site, RFI's should be faxed to Julian at the URS Greiner Fort Worth office.

12. Contractor Access to AOA

Leslie Sagar stated that the Contractor had requested the lock combinations to the access gates to the AOA. Curt Horn stated that he would provide those to Jim Gardner by the end of the day.

ADDISON AIRPORT

Construct West Side Taxiway and Drainage Improvements

Construction Progress Meeting Minutes – April 23, 1998

Page 3

Jim Gardner asked what the procedure should be for them obtaining access on the AOA and whether they would have to coordinate with AATI and the FAA every morning. Curt Horn explained that the Contractor would have to be in communication with the FAA Tower when they want to access aircraft movement areas (active taxiways) and that he would coordinate with Al Devane, FAA Tower Chief at Addison, and ask him to attend the next Construction Progress Meeting on April 30.

13. DBE Information

Leslie Sagar provided a DBE information form to Jim Gardner which the Contractor needs to fill out with the contract dollar amount awarded to their DBE subcontractors. Ms. Sagar advised that at the end of the project the Contractor will be asked to provide the total amount paid to the DBE subcontractors. The forms are to be submitted to Ms. Sagar and she will forward them to Clyde Johnson, the Town's Purchasing Manager.

14. Other Items

Leslie Sagar advised that a "Test Strip" of the TxDOT Item 340 asphalt base would not be required. The "Test Strip" applies only to P-401 Bituminous Material which was for Alternate No. 2, not Alternate No. 1.

Everyone agreed that the next Construction Progress Meeting should be held on April 30 at 10:00am.

Jim Gardner asked about daily security procedures and the training AATI will provide, and the need for a wing-walker to guide pilots. Curt Horn stated that he would arrange for a meeting with the FAA and the Contractor in which they would go over the procedures related to security and access to the AOA. Mr. Horn also stated that a wing-walker would be necessary to guide pilots at the Taxilane 1-2 cross-over.

Jim Gardner asked if the Engineer had a special Pay Request format. Leslie Sagar advised him to provide a format for her review.

Jim Gardner asked about working in the ILS critical area. Curt Horn explained that in inclement weather (Instrument Flight Rule (IFR) conditions) during north flow operations the Contractor may not be able to work in the ILS critical area because the heavy equipment and vehicles could disrupt the glide slope and localizer signal. Mr. Horn stated that he would invite the FAA Tower Chief to the next meeting so that he can explain how the Contractor will need to coordinate with the FAA during IFR conditions.

cc: Attendance list

Jim Pierce

From: Jim Pierce
Sent: Tuesday, April 28, 1998 9:01 AM
To: Jim Gardner@aol (E-mail)
Cc: Leslie Sagar/URS Greiner (E-mail)
Subject: Westside Taxiway Permits

Town permits required are: Building Permit – no fee. Building Permit requires a Contractor's License, \$50; Master Electrician's License, \$10 and Journeyman Electrician's License, \$6. All available at the Service Center. Jim.

Post-it® Fax Note	7671	Date	4/28/98	# of pages	▶ 1
To	Jim Gardner	From	Jim Pierce		
Co./Dept.	H. B. Zachry	Co.	Addison		
Phone #		Phone #			
Fax #	972-267-0435	Fax #			

Jim - I tried to E mail this earlier but it didn't go through. Please E mail me your address(es) to be sure I have them right.

j.pierce@ci.addison.tx.us

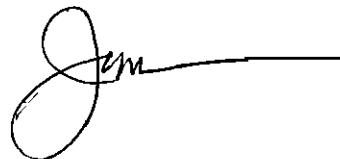

MODE = TRANSMISSION

START=04-28 01:43PM

END=04-28 01:44PM

NO.	CDM	SPEED NO	STATION NAME/ TELEPHONE NO.	PAGES
-----	-----	----------	--------------------------------	-------

001	OK	2	99722670435	001
-----	----	---	-------------	-----

-Addison Svc Ctr -Upstairs-

facsimile
TRANSMITTAL

to: Jim Gardner / H. B. Zachry
fax #: (972) 267-0435
re: Addison West Taxiway - Proposed Phasing Modifications
date: April 27, 1998
pages: 5, including this cover sheet.

In response to your request last Thursday that we perform a preliminary review of proposed phasing modifications to the West Taxiway project at Addison Airport, URS Greiner and AATI have reviewed the sketches you provided (attached). Based on our preliminary review, we are of the opinion that the proposed phasing changes can be accomplished provided that you meet the following requirements:

1) **Runway Displacement** - During Stage 1, the displacement of the runway threshold for the reconstruction of Taxiway C must be limited to the time necessary for the Taxiway C work to be accomplished (i.e. there is no need to displace the runway threshold for the entire duration of Stage 1). That is, once the threshold is displaced, the work on Taxiway C within the Runway Safety Area must begin and be completed promptly. When completed, the threshold will revert back to the runway end, even though there may be other components of Stage 1 still underway.

2) **Demarcation Between Stage 1 and Stage 2 on Taxiway C** - The demarcation line between Stage 1 and Stage 2 on Taxiway C needs to be located at Station 0+70 on Taxiway C, which will be the location of an expansion joint. See Sheet 20 of the plans for location of Joint Type B.

3) **Aircraft Access During Stage 1** - It is our understanding that you intend to perform the Stage 1 work on Taxiway E during night-time operations and that throughout Stage 1 aircraft will be able to access the east side via Taxiway E. We have also assumed that you will be providing the temporary connection between Taxiway 9 and 10 depicted on Sheet 5 of the plans so that aircraft will still be able to have ingress and egress to Building No. 92.

4) **Aircraft Access During Stage 2** - It is our understanding that during Stage 2 the aircraft will access the east side via the existing Taxiway B and Taxiway C. Since the aircraft must transition from new Taxiway B pavement to existing Taxiway B pavement and then to new Taxiway C pavement, the Contractor must ensure a minimum route width of 35 ft., and that the maximum profile along the route does not exceed 2%. In addition, temporary striping should be placed to help guide the pilots.

By having the demarcation line between Stage 1 and Stage 2 at the expansion joint location (Station 0+70), it may be necessary for the Contractor to add additional paving at the transition from the existing Taxiway B to the new Taxiway C pavement to achieve the 35 ft. width.

From the desk of...

Leslie V. Sagar, P.E.
Project Manager
URS GREINER, INC.
4100 Aron Carter Blvd., Suite 108
Fort Worth, Texas 76155

(817) 545-0801
Fax: (817) 545-0634

5) **Contractor's Haul Road Parallel to Taxiway B** - The sketches you provided for Stages 1 and 2 depict construction traffic parallel to Taxiway. We have a concern that there may not be sufficient room on Airport property, particularly in the vicinity of the Taxiway 1-2 crossover. Please review the proposed route relative to the existing fence location so that the route is within the Airport property line.

Please let me know if you have any questions regarding our preliminary review of the proposed phasing modifications. We will need to see a more detailed phasing plan which encompasses the entire project before a final approval can be made.

Ushie Sagar

cc:

Jim Pierce - Town of Addison

Zane Ryan - AATI

➔ AIRCRAFT TRAFFIC

⇨ CONSTRUCTION TRAFFIC



STAGE #1 CONSTRUCTION (plus the work at the north end)

Access from the west side to the east side is via Taxiway E.

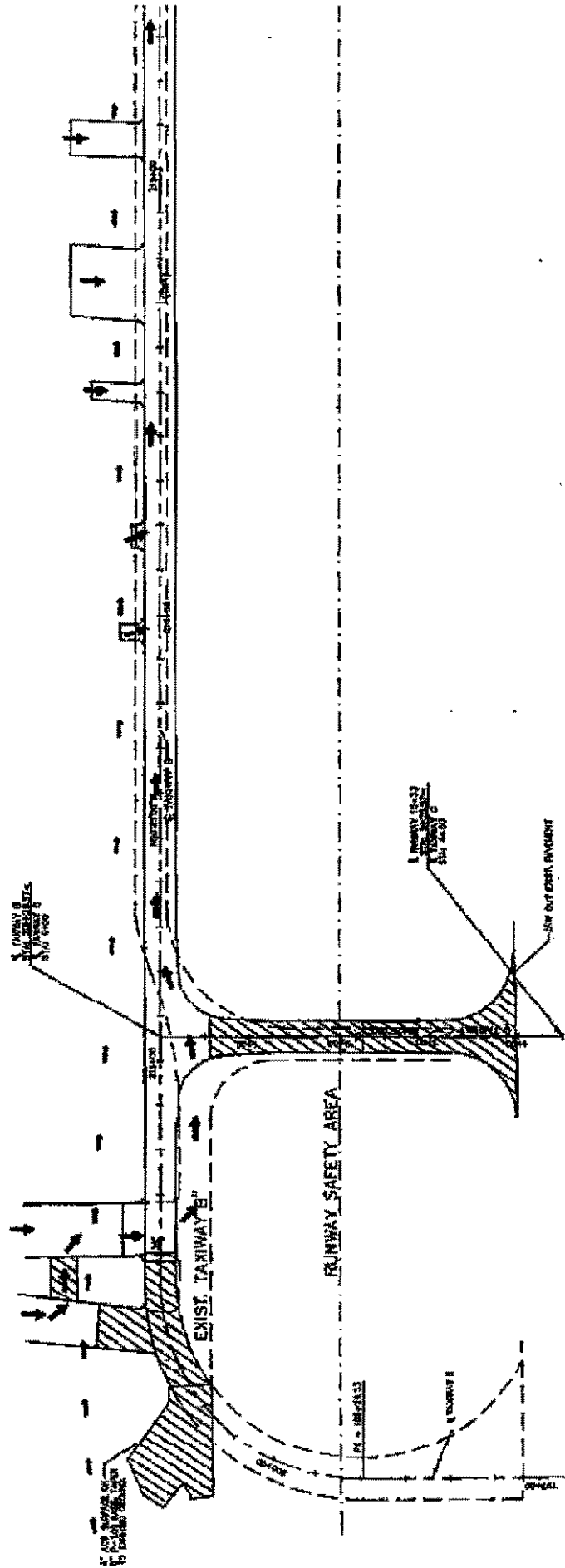

➔ AIRCRAFT TRAFFIC

⇨ CONSTRUCTION TRAFFIC

● STAGE #2 CONSTRUCTION

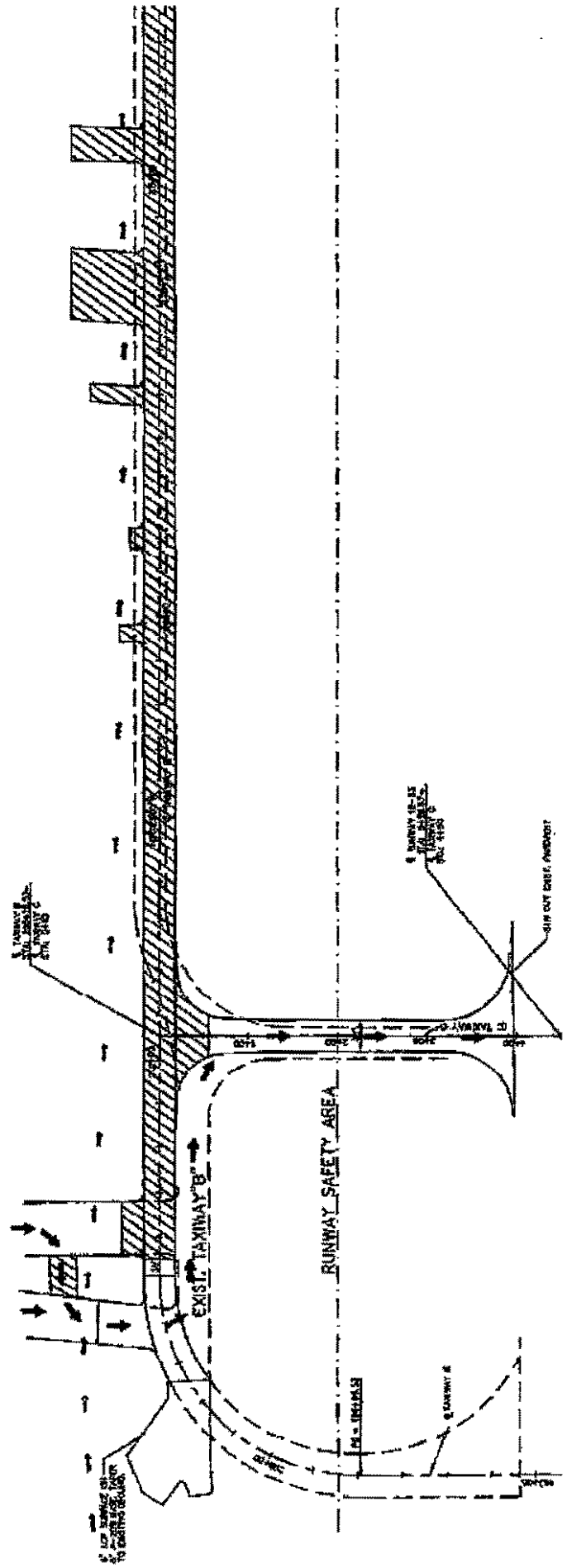

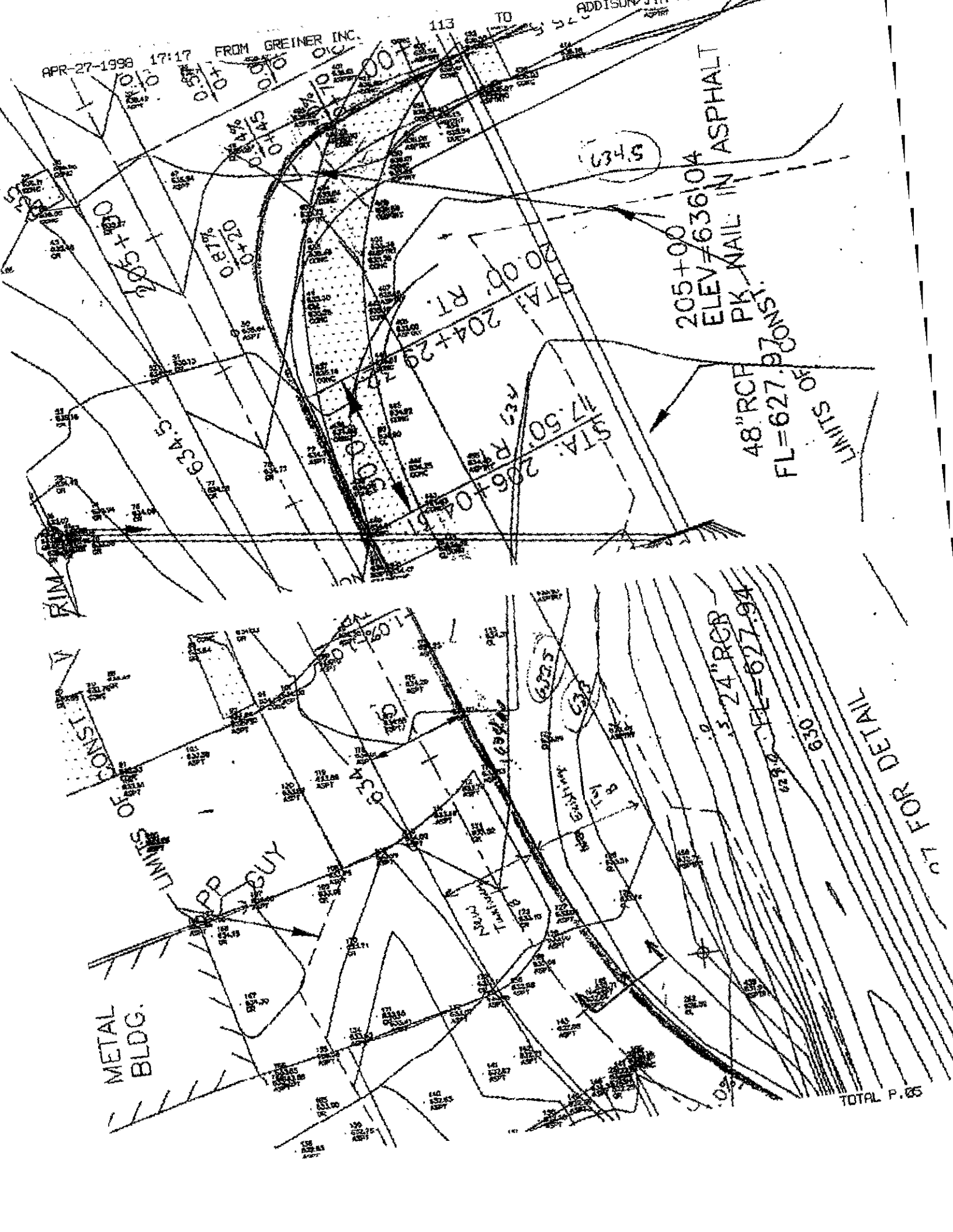

634.5

205+00
ELEV=636.04
PK NAIL IN ASPHALT

48" RCP
FL=627.97 NOS.

LIMITS OF

RIM
LIMITS OF
CONCRETE

METAL
BLDG.

PP
GUY

3.5' 24" RCP
ELEV=627.94

7 FOR DETAIL

facsimile
TRANSMITTAL

to: Zane Ryan / AATI
fax #: (972) 248-2416
re: Addison West Taxiway
date: April 24, 1998
pages: 4, including this cover sheet.

At the end of the Construction Progress Meeting yesterday, the Contractor requested that we consider allowing them to adjust the phasing for the project from three phases to two. Attached are some sketches prepared by the Contractor which depict Stage 1 and Stage 2, as well as a sketch depicting some topographical information about the existing Taxiway B.

We have reviewed this request from the Contractor and are of the opinion that the proposed phasing changes can be accomplished provided that the Contractor meets the following requirements:

- 1) During Stage 1, the displacement of the threshold for the reconstruction of Taxiway C must be limited to the time necessary for the Taxiway C work to be accomplished (i.e. there is no need to displace the runway threshold for the entire duration of Stage 1).
- 2) The demarcation line between Stage 1 and Stage 2 on Taxiway C needs to be located at Station 0+70, which will be the location of an expansion joint. See Sheet 20 of the plans for location of Joint Type B.
- 3) During Stage 2, the aircraft will access the east side via the existing Taxiway B and Taxiway C. Since the aircraft must transition from new Taxiway B pavement to existing Taxiway B pavement and then to new Taxiway C pavement, the Contractor must ensure a minimum route width of 35 ft. and that the maximum profile along the route does not exceed 2%. In addition, temporary striping should be placed to help guide the pilots.

By having the demarcation line between Stage 1 and Stage 2 at the expansion joint location (Station 0+70), it may be necessary for the Contractor to add additional paving at the transition from the existing Taxiway B to the new Taxiway C pavement to achieve the 35 ft. width.

Before I respond to the Contractor with our comments above, please review this proposed phasing plan and let me know if you have any other comments. A timely response will be appreciated.

Leslie Sagar

cc: Jim Pierce

From the desk of...
Leslie Y. Sagar, P.E.
Project Manager
URS GREINER, INC.
4100 Arnon Carter Blvd., Suite 108
Fort Worth, Texas 76155
(817) 545-0891
Fax: (817) 545-0534

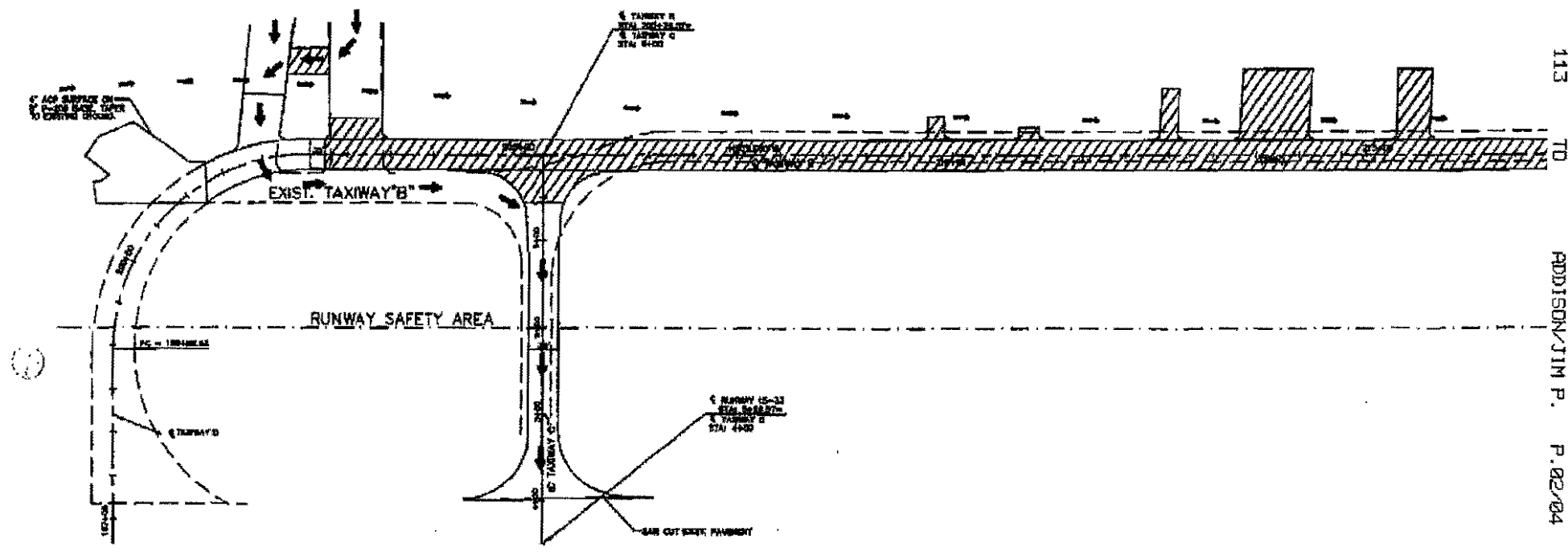
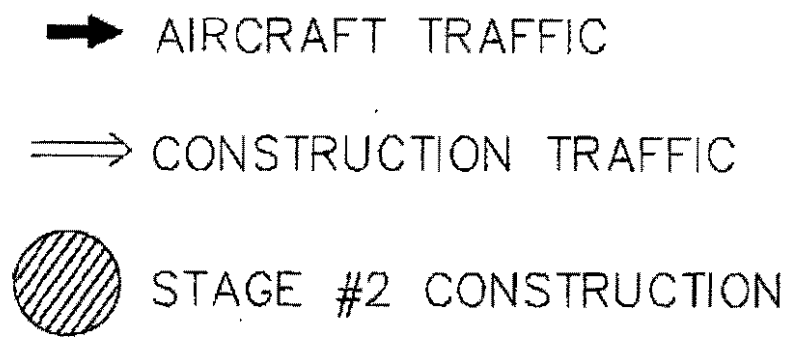

Contractors
License Fee - \$50

ADDISON AIRPORT

CONSTRUCT WEST TAXIWAY AND CONNECTORS WITH DRAINAGE IMPROVEMENTS
(SOUTH SEGMENT)
TXDOT PROJECT NO. 9248 ADDSN

CONSTRUCTION PROGRESS MEETING NO.1
APRIL 23, 1998
AGENDA

- 1. Contractor's Notice to Proceed Date
 - a. Request to delay until May 6, 1998 *approved — Liskie will notify tower, Zane*

2. Project Schedule Submittal

- 3. Modification to Runway Closure Period for Taxiways E and F
 - a. Equivalent Pavement Sections *Option 1 & 2 will be period out*
 - b. Request for Cost Proposals: *will have by Tuesday*
 - One (1) weekend closure (9 pm Fri. thru 6 am Mon.)
 - Night-time work (9 pm thru 6 am)

- 4. Permits *Any city permits needed?* *Temp Electric - TAXIway Lights? use FT as water source for Trailers*

- 5. Contractor's Quality Control Program
 - a. Submittal of written program
 - b. Program Administrator and QC Technicians

- 6. Submittals Schedule
 - a. Submittal of detailed listing of all submittals (mix designs, materials certifications, shop drawings)

- 7. Quality Control Testing Plan
 - a. Submittal of spreadsheet of project requirements

- 8. Documentation / Quality Control Records
 - a. Daily Inspection Reports
 - b. Daily Test Reports
 - c. Form review and approval by Engineer
 - d. Submittal of reports*6 copies - Address to Julian @ VRS Greener / Ft. Worth*

- 9. Safety on the Airport During Construction
 - a. FAA Order 5200.5A - *Airport Safety During FAA Funded Airport Construction and FAA Facilities Maintenance*

10. Protection of Existing Underground Cables

- 11. Contractor's Requests for Information (RFI's) *Thru Julian*

12. Contractor Access to AOA *Need gate combinations*

✓ 13. DBE Information

- 14. Other Items *Danny Gleason - Zachry / Electrical*
- Next meeting Apr 30th*

Electrical

will submit next week

facsimile
TRANSMITTAL



to: Jim Gardner / H.B. Zachry
fax #: (972) 267-0435
re: Addison West Taxiway
date: April 22, 1998
pages: 2, including this cover sheet.

As a follow-up to our discussions regarding the Town of Addison's desire to reduce the runway closure time, the following are some equivalent pavement sections for Taxiway F that may be more time efficient with respect to placement of the materials:

Option 1

- 10" PCC (P-501)
- 6" Cement Treated Base (P-304)
- 9" Lime Treated Subgrade (premixed/precured prior to placement and compaction)

Option 2

- 10" PCC (P-501)
- 4" Bituminous Base (TxDOT Item 340)
- 9" Lime Treated Subgrade (P-155, premixed/precured prior to placement and compaction)

Option 3

- 10" PCC (P-501)
- 6" Aggregate Base (P-209)
- 9" Lime Treated Subgrade (P-155, premixed/precured prior to placement and compaction)

Please review these pavement sections and let me know your comments.

As you know, the contract documents currently specify that the work associated with Taxiway Connectors E and F located within the Runway Safety Area must be accomplished within two weekend periods, during which time the runway would be closed. Since the Town of Addison would like to minimize the impacts associated with a two weekend runway closure, please prepare two cost proposals to accomplish this work as follows:

1) Within one (1) weekend closure period beginning at 9pm on Friday and ending at 6am on Monday.

2) During night-time closures beginning at 9pm and ending at 6am.

When assessing the costs associated with these two

From the desk of...

Leslie V. Sagar, P.E.
Project Manager
URS GREINER, INC.
4100 Amon Carter Blvd., Suite 108
Fort Worth, Texas 76155

(817) 545-0891
Fax: (817) 545-0534

scenarios, please be advised that it is not necessary for all work within the runway safety area to be completed prior to re-opening the runway. The runway may be re-opened for use as long as there is a pavement edge drop off no greater than 3 inches, and there is no more than a 20:1 slope.

Please give me a call if you have any questions regarding the pavement sections or the two proposal scenarios.

Leslie Jagan

cc: Jim Pierce - Town of Addison



James Pierce

From: John Baumgartner
Sent: Wednesday, April 22, 1998 3:12 PM
To: James Pierce
Subject: RE: Westside Taxiway

Jim,

This works for me. I wish they would have said something at the preconstruction meeting. Please make sure that Leslie, Kurt, Bruce Ehly, Zane, the tower, airway facilities, etc. are on board with that decision.

John

-----Original Message-----

From: James Pierce
Sent: Wednesday, April 22, 1998 12:49 PM
To: John Baumgartner
Subject: Westside Taxiway

On 4/15 Clyde sent a Notice to Proceed to Zachry to start const no later than 4/25 (a Saturday). HBZ has asked for a May 6 start date (8 more working days) to get subs in place and get materials ready. Are you OK with that? Jim.

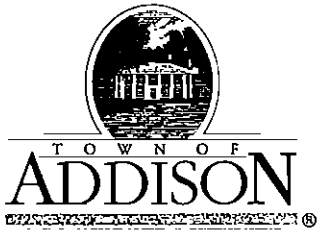

PUBLIC WORKS DEPARTMENT

(972) 450-2871

Post Office Box 144 Addison, Texas 75001

16801 Westgrove

April 23, 1998

Mr. James Gardner, Project Manager
H.B. Zachry Company
16101 Dooley Road
P.O. Box 1004
Addison, TX 75001-1004

Re: Addison Airport Westside Taxiway

Dear Mr. Gardner:

We have received your letter of April 21, 1998 requesting a delay in the start date for the above referenced project from April 25, 1998 to May 6, 1998.

Your request is approved.

Very truly yours,

Town of Addison

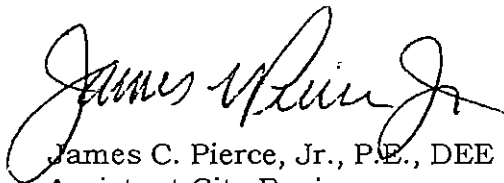

James C. Pierce, Jr., P.E., DEE
Assistant City Engineer

cc: John Baumgartner
Leslie Sagar

April 21, 1998

Mr. James C. Pierce, Jr., P.E., DEE
Assistant City Engineer
Town of Addison
16801 Westgrove
P.O. Box 144
Addison, TX 75001

Letter No. ATX 101

Reference: Addison West Taxiway and Connectors with Drainage Improvements
Bid No. 98-04 TxDOT Project No. 9248 ADDSN
HBZ Job No. 4744

Dear Mr. Pierce,

In response to the Town of Addison's letter (April 15, 1998) that states work shall begin on April 25, 1998, we request the start date be delayed until May 6, 1998.

Our purchasing department received the signed contract from the Town of Addison on April 17 and they are currently expediting the approval and signing of subcontracts and purchase orders for the project. It appears that this process will be substantially completed by May 6 and, at that time, we would be ready to begin work.

Your consideration of this request is greatly appreciated. If I can be of any assistance, please call me at (972) 267-0430.

Sincerely,

N.B. ZACHRY COMPANY

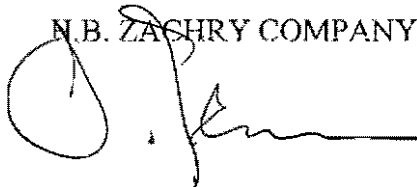

James Gardner
Project Manager

cc: Brian Salerno
Clyde Johnson
Leslie Sagar



FINANCE DEPARTMENT / PURCHASING DIVISION

5350 Belt Line Road

(214) 450-7091 - Facsimile (214) 386-0938

Post Office Box 144 Addison, Texas 75001

CLYDE JOHNSON, C.P.M.
PURCHASING MANAGER

New: Phone (972) 450-7090 Facsimile (972) 450-7096 P.O. Box 9010

April 15, 1998

Mr. David S. Zachry
H.B. Zachry Company
P.O. Box 240130
San Antonio, TX 78224-0130

NOTICE TO PROCEED: Construct West Taxiway and Connectors with Drainage Improvements (South Segment) Addison Airport, Town of Addison, Texas. Bid No. 98-04

Dear Mr. Zachry:

Receipt of this document authorizes your company to provide all labor and materials as outlined in the specifications, and under the terms and conditions of the contract documents for Bid No. 98-04

Enclosed please find a completed copy of the contract documents for your file.

Work shall begin as soon as possible, but no later than April 25, 1998, and be completed within one hundred and eighty (180) calendar days after work begins. Please contact me at 972-450-7090, if you have any questions, or if I can be of assistance to you.

Sincerely yours,

Enclosures

copy: John Baumgartner
Jim Pierce

facsimile
TRANSMITTAL

to: Jim Gardner / H. B. Zachry
fax #: (972) 267-0435
re: Addison West Taxiway
date: April 20, 1998
pages: 1, including this cover sheet.

Reminder - Please note that on page P-156-2 of the technical specifications for this project that the Contractor is responsible for submitting an Erosion Control and Pollution Prevention Plan to the Engineer and for filing a Notice of Intent (NOI) with the Environmental Protection Agency prior to the start of construction (See Section 156-3.2 of Item P-156 Temporary Air and Water Pollution, Soil Erosion and Siltation Control).

Leslie Sagar

cc: Jim Pierce

From the desk of...

Leslie V. Sagar, P.E.
Project Manager
URS GREINER, INC.
4100 Amon Carter Blvd., Suite 108
Fort Worth, Texas 76155

(817) 545-0891
Fax: (817) 545-0634

facsimile
TRANSMITTAL

to: Town of Addison
John Baungartner
Jim Pierce
Clyde Johnson

fax #:

re: Addison West Taxiway PreConstruction Conference

date: April 15, 1998

pages: 6, including this cover sheet.

Attached for your review and information are the meeting minutes from the April 3, 1998 PreConstruction Conference for the West Taxiway and Connectors with Drainage Improvements Project at Addison Airport.

Reminder: The first construction progress meeting is scheduled on Thursday, April 23 at 10:00 a.m. in the Addison Service Center at 16801 Westgrove.

Leslie Sagar

From the desk of...

Leslie V. Sagar, P.E.
Project Manager
URS GREINER, INC.
4100 Amon Carter Blvd., Suite 108
Fort Worth, Texas 76155

(817) 545-0891
Fax: (817) 545-0534

URS Greiner

Project No. E708024.81

ADDISON AIRPORT
Construct West Side Taxiway and Drainage Improvements
Pre-Construction Conference

Minutes of Meeting
April 3, 1998

ATTENDEES: See attached Attendance List

A Pre-Construction Conference was held at the Town of Addison Service Center on Friday, April 3, 1998 to coordinate and discuss the upcoming construction project at the Addison Airport. An attendance list is attached.

General Items

Relationships and responsibilities were discussed regarding the Town of Addison, Addison Airport management (AATI), and the Engineer (URS Greiner).

Jim Gardner, Project Manager, and Wayne Crabtree, Superintendent, were introduced as H.B. Zachry's representatives.

Julian Wise was identified as the Resident Project Representative. He will be the Engineer's representative on-site, acting on behalf of the Town of Addison. The Contractor shall correspond with the Engineer and Town through Mr. Wise. Mr. Wise will notify the Air Traffic Control Tower (Tower) of the anticipated construction on a daily basis.

Zane Ryan was identified as AATI's (Addison Airport management's) representative. Zane will be responsible for tenant notification of the construction progress and phase changes. Zane will coordinate with the Tower regarding NOTAMS and construction progress.

Administrative Issues

The Town of Addison anticipates issuing the Notice of Award to the Contractor April 6, 1998. Upon execution of the contract and submission of required insurance certificates, the tentative Notice-to-Proceed date is April 27, 1998. The Contractor will notify the Town if this date needs to change.

A preliminary contact list was provided to the meeting attendees. Phone numbers for Julian Wise and the designated 24-Hour contacts for both H. B. Zachry and AATI will be determined, and a revised contact list will be distributed to all.

The Contractor's Staging Area will be located at the south end of the west side taxiway. Jim Gardner indicated H. B. Zachry would keep their construction office in the same location as is currently being used for the tunnel construction. The RPR's trailer will be located in the Contractor's Staging Area on the project.



ADDISON AIRPORT**Construct West Side Taxiway and Drainage Improvements**

Pre-Construction Conference Meeting Minutes – April 3, 1998

Page 2

Weekly progress reports (FAA Form 5370) will be filed by Julian Wise. Copies of this report will be forwarded to Bruce Ehly monthly.

Pay applications will be submitted by the Contractor by the 20th of every month to Julian Wise for review and agreement on quantities completed to date. Allowing for 5 days of review and revision, the pay applications will then be forwarded to the Town of Addison for payment by the 25th of every month.

Certified Payrolls will be submitted to Julian Wise for review weekly. Wages shall be in accordance with those Davis-Bacon wages included in the Bid Documents.

Clyde Johnson, Town of Addison Purchasing Department, has a form to be submitted by the Contractor regarding Disadvantaged Business Enterprise (DBE) participation in the project. The form is required at the start of the project, and will be revised at the end of construction to indicate the actual DBE participation realized.

The Contractor shall submit shop drawings and requests for information (RFIs) directly to the Albuquerque office of URS Greiner, with a copy of the transmittal and shop drawing or RFI submitted to Julian Wise. A minimum of 6 copies of all submittals will be required. URS Greiner will endeavor to return all submittals to the Contractor within a 10 day period, including a copy sent directly to Julian Wise for his on-site files.

Requests for Change Orders and/or time extensions are to be submitted to Julian Wise, who will forward as necessary for action.

Weekly construction progress meetings will be held Thursdays at 10 a.m. at the Town of Addison Service Center, starting Thursday, April 23, 1998.

No The Contractor is responsible for obtaining any permits necessary. ~~The Town of Addison has filed the Notice of Intent required by the NPDES permit process.~~

Construction Items

Horizontal and vertical control staking will be provided by the Engineer. The Contractor is responsible for his own construction staking. The FAA will mark their cables in the project site. All utilities known are shown on the construction plans, and no others are anticipated to be uncovered during the construction of the taxiway and drainage improvements.

Copies of all construction quality control tests are to be provided to Julian Wise. Failed tests are to be reported immediately, along with the plan of action to correct the deficiency.

The Contractor questioned the need for the 300-foot by 50-foot asphalt test strip, since the concrete alternate was selected by the Owner, and the entire quantity of P-401 asphalt to be constructed would almost comprise the test strip. With the agreement of Bruce Ehly, TxDOT Project Manager, the test strip has been waived.



ADDISON AIRPORT**Construct West Side Taxiway and Drainage Improvements****Pre-Construction Conference Meeting Minutes -- April 3, 1998**

Page 3

Safety Issues

The phasing of the construction was discussed in relation to maintaining access for aircraft located on the west side of the airport. The Contractor will maintain a clean, active taxiway. Other means for access to the construction site were discussed to limit the interaction between construction vehicles and the active taxiway.

Control of contractor traffic was discussed, and elimination of incursions from persons unfamiliar with airport operations was emphasized. The Contractor committed to employing measures to control traffic through the construction access gates and onto the site.

Special Issues

As Addison Airport has a single runway, any closure of the runway, even the two weekend closure as allowed in the bid documents, is unfavorable to the airport management and users. Jim Gardner agreed to work with URS Greiner to try to develop alternate means and methods (pavement sections or temporary construction) to limit closure as much as possible, including nighttime construction operations between 9 p.m. and 6 a.m. The Town of Addison agreed to consider a change order regarding the compressed runway closure time.

Construction of the taxiway tie-ins to the runway are the main catalyst for runway closure. Drop-offs greater than 3 inches will not be permitted within the runway safety area (200 feet from centerline) of an active runway. In order to re-open the runway, electrical trenches will be required to be backfilled or otherwise covered so as not to pose a hazard. Completion of the light units themselves will not necessarily be required during the weekend/nighttime closure of the runway for pavement operations, but may be completed during additional nighttime closures as necessary.

The Glide Slope will be affected and turned off during Phases 2 and 3 due to contractor operations potentially causing a shadow effect on the ILS. The Localizer will be affected and turned off during the displacement of the threshold during Phase 3 (45 days maximum).

cc: Attendance list

E77024.11
P:\OCCS\PRECON\PRECON.MXD

SIGN-IN SHEET

PRECONSTRUCTION CONFERENCE

ADDISON AIRPORT
WEST TAXIWAY AND CONNECTORS WITH DRAINAGE IMPROVEMENTS
TABOT PROJECT NO. 948 ADDSN

Friday, April 3, 1998
10:30 a.m.

	NAME	ORGANIZATION	TELEPHONE	FAX
1	Leslie Sagar	VRS Greiner - Ft. Worth	(817) 545-0891	(817) 545-0534
2	Carol Gerwin	VRS Greiner - ABQ	(505) 345-3999	(505) 345-3893
3	Jack Tjepens	VRS Greiner - ABQ	(505) 345-3999	(505) 345-8193
4	Jim Pierce	Team of Addison	972-450-2879	972-450-2834
5	Julian R. Wise	Wise Contracting Southwest, Inc.	908-389-7404	908-389-7404
6	Larry Bracke	Merlin Technologies	914-920-1881	214-820-1881
7	Charlotte Benfield	TRIST Aviation	1-800-687-9568	612-414-4510
8	John Baumgardner	Team Addison	972-450-2871	972-450-2834
9	BOBBE SMITH	TRIST AVIATION	1-800-687-9568	512-414-4510
10	JIM GARDNER	H.B. ZACHRY CO.	972-267-0430	972-267-0435
11	DAVID GLENN	H.B. ZACHRY CO.	972-267-0430	972-267-0435
12	CAROLINA J. TERPANA	H.B. ZACHRY CO.	972-267-0430	972-267-0435
13	Scott Hutchins	H.B.Z.	972-262-0430	972-264-5597
14	Bobby Paulley Sr.	H.B.Z. Co.	972-262-0430	972-267-0435
15	Aleane Crabbtree	H.B. Zachry	972-267-0430	972-267-0435
16	Mered Liman	H.B. Zachry	972-267-0430	972-267-0435
17	Michael V. Mowery	Austin Bridge & Road	972-241-2783	972-241-3369
18	CURTIS H. GRAY	F.A.A. ADDISON TOWER	972-490-4750	972-490-7324
19				
20				



SIGN-IN SHEET

PRECONSTRUCTION CONFERENCE

ADDISON AIRPORT
 WEST TAXIWAY AND CONNECTORS WITH DRAINAGE IMPROVEMENTS
 TxDOT PROJECT NO. 9248 ADDSN

Friday, April 3, 1998
 10:30 a.m.

NAME	ORGANIZATION	TELEPHONE	FAX
1 Sam Stuart	AATI	972-248-7733 ^{FAT} 103	972-248-2416
2 ZANE RYAN	✓	✓ 105	✓
3 Joe Scott	Austin Bridge & Road	817	
4 Tim Crason	Austin Bridge & Road	972-241-0699	972-241-3831
5 Brian Arant	Austin Bridge & Road		
6 Doug Best	Austin Bridge & Road	972-241-0699	
7 Nancy Wise	Wise Contracting - Sensitt, Inc	903-389-7904	Same
8			
9			
10			
11			
12			
13			
14			
15			
16			
17			
18			
19			
20			

TOTAL P.06

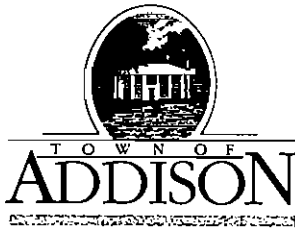

FINANCE DEPARTMENT / PURCHASING DIVISION

5350 Belt Line Road

(214) 450-7091 • Facsimile (214) 386-0938

Post Office Box 144 Addison, Texas 75001

CLYDE JOHNSON, C.P.M.
PURCHASING MANAGER

New: Phone (972) 450-7090 Facsimile (972) 450-7096 P.O. Box 9010

April 15, 1998

Mr. David S. Zachry
H.B. Zachry Company
P.O. Box 240130
San Antonio, TX 78224-0130

NOTICE TO PROCEED: Construct West Taxiway and Connectors with Drainage Improvements (South Segment) Addison Airport, Town of Addison, Texas. Bid No. 98-04

Dear Mr. Zachry:

Receipt of this document authorizes your company to provide all labor and materials as outlined in the specifications, and under the terms and conditions of the contract documents for Bid No: 98-04

Enclosed please find a completed copy of the contract documents for your file.

Work shall begin as soon as possible, but no later than April 25, 1998, and be completed within one hundred and eighty (180) calendar days after work begins. Please contact me at 972-450-7090, if you have any questions, or if I can be of assistance to you.

Sincerely yours,

Enclosures

copy: John Baumgartner
Jim Pierce

facsimile
TRANSMITTAL

to: Jim Pierce / Town of Addison
fax #: (972) 450-2834
re: Addison Airport - West Taxiway
date: April 14, 1998
pages: 2, including this cover sheet.

As a follow-up to our telephone conversation yesterday, I have obtained a clarification on the Notice of Intent (NOI) form. The NOI is typically filled out and signed by the Owner/Sponsor and submitted to the EPA. A copy of the NOI form is attached.

Since the Contractor is responsible for obtaining permits and complying with all applicable laws, etc., he must be provided with a copy of the Airport's Storm Water Pollution Prevention Plan (SWPPP) and be advised that he must comply with it. I suggest a simple form for the Contractor to sign which acknowledges receipt of the SWPPP and his understanding that he must comply. If you like, I can draft up a form for this purpose.

Karen Griffin and I both worked up the meeting minutes for the Pre-Construction Conference and she recalled John Baumgartner stating that the Town would take care of the NOI. So I suggest you confirm with John that the Town does have a SWPPP for the Airport and the latest NOI form.

I suggest we provide the SWPPP to the Contractor at the construction progress meeting on April 23rd.

Please let me know if John has a different understanding regarding the NOI form, because I would like to send out the meeting minutes.

Also, please let me know if you need any assistance with the NOI form.



From the desk of...

Leslie V. Sagar, P.E.
Project Manager
URS GREINER, INC.
4100 Arnon Carter Blvd., Suite 108
Fort Worth, Texas 76155

(817) 545-0891
Fax: (817) 545-0534

THIS FORM REPLACES PREVIOUS FORM 3510-G (8-98) Form Approved, OMB No. 2040-0188
 See Reverse for Instructions

NPDES FORM  **United States Environmental Protection Agency**
 Washington, DC 20460
Notice of Intent (NOI) for Storm Water Discharges Associated with CONSTRUCTION ACTIVITY Under a NPDES General Permit

Submission of this Notice of Intent constitutes notice that the party identified in Section I of this form intends to be authorized by a NPDES permit issued for storm water discharges associated with construction activity in the State/Indian Country Land identified in Section II of this form. Submission of this Notice of Intent also constitutes notice that the party identified in Section I of this form meets the eligibility requirements in Part I.B. of the general permit (including those related to protection of endangered species determined through the procedures in Attachment A of the general permit), understands that continued authorization to discharge is contingent on maintaining permit eligibility, and that implementation of the Storm Water Pollution Prevention Plan required under Part IV of the general permit will begin at the time the particular construction work on the construction project identified in Section II below. **IN ORDER TO OBTAIN AUTHORIZATION, ALL INFORMATION REQUESTED MUST BE INCLUDED ON THIS FORM. SEE INSTRUCTIONS ON BACK OF FORM.**

I. Owner/Operator (Applicant) Information

Name: _____ Phone: _____
 Address: _____
 City: _____ State: _____ Zip Code: _____
 Status of Owner/Operator:

II. Project/Site Information

Project Name: _____ Is the facility located on Indian Country Land?
 Yes No

Project Address/Location: _____
 City: _____ State: _____ Zip Code: _____
 Latitude: _____ Longitude: _____ County: _____
 Has the Storm Water Pollution Prevention Plan (SWPPP) been prepared? Yes No

Option: Address of location of SWPPP for viewing Address in Section I above Address in Section II above Other address (if known) below:
 SWPPP Address: _____ Phone: _____
 City: _____ State: _____ Zip Code: _____
 Name of Receiving Water: _____
 Month Day Year _____ Month Day Year _____
 Estimated Construction Start Date Estimated Completion Date

Estimate of area to be disturbed (to nearest acre): _____
 Estimate of Likelihood of Discharge (choose only one):
 1. Unlikely 2. Once per month 3. Once per week 4. Once per day 5. Continuous

Based on information provided in Attachment A of this permit, are there any listed endangered or threatened species, or designated critical habitat in the project area?
 Yes No

I have satisfied permit eligibility with regard to protection of endangered species through the included section of Part I.B. of the permit (check one or more boxes):
 (a) (b) (c) (d)

III. Certification

I certify under penalty of law that this document and all attachments were prepared under my direction or supervision in accordance with a system designed to assure that qualified personnel properly gather and evaluate the information submitted. Based on my inquiry of the persons who manage this system, or those persons directly responsible for gathering the information, the information submitted is, to the best of my knowledge and belief, true, accurate, and complete. I am aware that there are significant penalties for submitting false information, including the possibility of fine and imprisonment for knowing violations.

Print Name: _____ Date: _____
 Signature: _____

EPA Form 3510-G replaced 3510-G (8-98)

4-15-98

Westside Taxiway

~~4/16~~

Stormwater NOI

Spoke to Lee Solomon, SAIC

SAIC

@ Stormwater Hotline 800-245-6510

NOI can be filed by the Owner,
Operator or the Contractor.

I advised our specs require Contractor to
file the NOI and produce a SWPPP
for the project. Mr. Solomon stated
that would work just fine.

Claudia Haas - EPA, Region 6: 214-665-6464

Owner and Contractor must file a NOI
However, Const Permit expired Sept 9, 1997.

But to cover all bases, EPA recommends
filing the NOI. We probably won't get a
permit. Dual filing extends liability
to the owner.

Even tho the airport has a multi
sector permit, the new taxiway construction
doesn't come under airport operations so
this activity doesn't come under their
permit. The airports SWPPP should address
sediment & erosion control for any activity
that would be considered their operations.

ICETEA exempted small municipalities
from getting permits for road const. except
airport operations

facsimile
TRANSMITTAL

to: Jim Pierce
fax #: (972) 450-2834
re: West Taxiway Pre-Construction Conference Meeting Minutes
date: April 9, 1998
pages: 6, including this cover sheet.

Attached are the meeting minutes from the Pre-Construction Conference last Friday for your review. With your concurrence I will fax the minutes to the meeting participants.

Leslie Sagar

From the desk of...

Leslie V. Sagar, P.E.
Project Manager
URS GREINER, INC.
4100 Amon Carter Blvd., Suite 108
Fort Worth, Texas 76155

(817) 545-0891
Fax: (817) 545-0534

URS Greiner

Project No. E70802A.81

ADDISON AIRPORT
Construct West Side Taxiway and Drainage Improvements
Pre-Construction Conference

Minutes of Meeting
April 3, 1998

ATTENDEES: See attached Attendance List

A Pre-Construction Conference was held at the Town of Addison Service Center on Friday, April 3, 1998 to coordinate and discuss the upcoming construction project at the Addison Airport. An attendance list is attached.

General Items

Relationships and responsibilities were discussed regarding the Town of Addison, Addison Airport management (AATI), and the Engineer (URS Greiner).

Jim Gardner, Project Manager, and Wayne Crabtree, Superintendent, were introduced as H.B. Zachry's representatives.

Julian Wise was identified as the Resident Project Representative. He will be the Engineer's representative on-site, acting on behalf of the Town of Addison. The Contractor shall correspond with the Engineer and Town through Mr. Wise. Mr. Wise will notify the Air Traffic Control Tower (Tower) of the anticipated construction on a daily basis.

Zane Ryan was identified as AATI's (Addison Airport management's) representative. Zane will be responsible for tenant notification of the construction progress and phase changes. Zane will coordinate with the Tower regarding NOTAMs and construction progress.

Administrative Issues

The Town of Addison anticipates issuing the Notice of Award to the Contractor April 6, 1998. Upon execution of the contract and submission of required insurance certificates, the tentative Notice-to-Proceed date is April 27, 1998. The Contractor will notify the Town if this date needs to change.

A preliminary contact list was provided to the meeting attendees. Phone numbers for Julian Wise and the designated 24-Hour contacts for both H. B. Zachry and AATI will be determined, and a revised contact list will be distributed to all.

The Contractor's Staging Area will be located at the south end of the west side taxiway. Jim Gardner indicated H. B. Zachry would keep their construction office in the same location as is currently being used for the tunnel construction. The RPR's trailer will be located in the Contractor's Staging Area on the project.

ADDISON AIRPORT**Construct West Side Taxiway and Drainage Improvements****Pre-Construction Conference Meeting Minutes - April 3, 1998**

Page 2

Weekly progress reports (FAA Form 5370) will be filed by Julian Wise. Copies of this report will be forwarded to Bruce Ehly monthly.

Pay applications will be submitted by the Contractor by the 20th of every month to Julian Wise for review and agreement on quantities completed to date. Allowing for 5 days of review and revision, the pay applications will then be forwarded to the Town of Addison for payment by the 25th of every month.

Certified Payrolls will be submitted to Julian Wise for review weekly. Wages shall be in accordance with those Davis-Bacon wages included in the Bid Documents.

Clyde Johnson, Town of Addison Purchasing Department, has a form to be submitted by the Contractor regarding Disadvantaged Business Enterprise (DBE) participation in the project. The form is required at the start of the project, and will be revised at the end of construction to indicate the actual DBE participation realized.

The Contractor shall submit shop drawings and requests for information (RFIs) directly to the Albuquerque office of URS Greiner, with a copy of the transmittal and shop drawing or RFI submitted to Julian Wise. A minimum of 6 copies of all submittals will be required. URS Greiner will endeavor to return all submittals to the Contractor within a 10 day period, including a copy sent directly to Julian Wise for his on-site files.

Requests for Change Orders and/or time extensions are to be submitted to Julian Wise, who will forward as necessary for action.

Weekly construction progress meetings will be held Thursdays at 10 a.m. at the Town of Addison Service Center, starting Thursday, April 23, 1998.

The Contractor is responsible for obtaining any permits necessary. The Town of Addison has filed the Notice of Intent required by the NPDES permit process.

Construction Items

Horizontal and vertical control staking will be provided by the Engineer. The Contractor is responsible for his own construction staking. The FAA will mark their cables in the project site. All utilities known are shown on the construction plans, and no others are anticipated to be uncovered during the construction of the taxiway and drainage improvements.

Copies of all construction quality control tests are to be provided to Julian Wise. Failed tests are to be reported immediately, along with the plan of action to correct the deficiency.

The Contractor questioned the need for the 300-foot by 50-foot asphalt test strip, since the concrete alternate was selected by the Owner, and the entire quantity of P-401 asphalt to be constructed would almost comprise the test strip. With the agreement of Bruce Ehly, TxDOT Project Manager, the test strip has been waived.

*Called Leslie
4-13-98 - Contr
normally does this
She will
check it out.*

ADDISON AIRPORT***Construct West Side Taxiway and Drainage Improvements******Pre-Construction Conference Meeting Minutes - April 3, 1998******Page 3*****Safety Issues**

The phasing of the construction was discussed in relation to maintaining access for aircraft located on the west side of the airport. The Contractor will maintain a clean, active taxiway. Other means for access to the construction site were discussed to limit the interaction between construction vehicles and the active taxiway.

Control of contractor traffic was discussed, and elimination of incursions from persons unfamiliar with airport operations was emphasized. The Contractor committed to employing measures to control traffic through the construction access gates and onto the site.

Special Issues

As Addison Airport has a single runway, any closure of the runway, even the two weekend closure as allowed in the bid documents, is unfavorable to the airport management and users. Jim Gardner agreed to work with URS Greiner to try to develop alternate means and methods (pavement sections or temporary construction) to limit closure as much as possible, including nighttime construction operations between 9 p.m. and 6 a.m. The Town of Addison agreed to consider a change order regarding the compressed runway closure time.

Construction of the taxiway tie-ins to the runway are the main catalyst for runway closure. Drop-offs greater than 3 inches will not be permitted within the runway safety area (200 feet from centerline) of an active runway. In order to re-open the runway, electrical trenches will be required to be backfilled or otherwise covered so as not to pose a hazard. Completion of the light units themselves will not necessarily be required during the weekend/nighttime closure of the runway for pavement operations, but may be completed during additional nighttime closures as necessary.

The Glide Slope will be affected and turned off during Phases 2 and 3 due to contractor operations potentially causing a shadow effect on the ILS. The Localizer will be affected and turned off during the displacement of the threshold during Phase 3 (45 days maximum).

cc: Attendance list

E7824.01
F:\DOCS\FRECON\FRECON.MDI

SIGN-IN SHEET

PRECONSTRUCTION CONFERENCE

ADDISON AIRPORT
 WEST TAXIWAY AND CONNECTORS WITH DRAINAGE IMPROVEMENTS
 TADOT PROJECT NO. 9446 ADDEN

Friday, April 3, 1998
 10:30 a.m.

NAME	ORGANIZATION	TELEPHONE	FAX
1 Leslie Sagar	VPS Greiner - Ft. Worth	(817) 546-0891	(817) 545-0934
2 Carol Griffin	VPS Greiner - AEG	(505) 345-3999	(505) 345-8398
3 Jack Tipton	VPS Greiner - HQ	(905) 345-3449	(905) 345-8113
4 Jim Kerce	Team of Addison	972-450-2879	972-450-2834
5 Julian B. Wise	Wise Contracting Consultants, Inc.	908-589-7404	908-589-7404
6 Larry Bracke	McKim - Bradburn	914-830-1888	914-830-1888
7 Charlotte Bursfield	T&E, Austin	1-800-687-1548	812-914-4510
8 John Boursma	Team of Addison	972-450-2871	972-450-2834
9 Bruce Smith	TADOT AVIATION	1-800-671-4567	512-914-4510
10 Jim Gardner	H.B. Zachary Co.	972-267-0430	972-267-0435
11 Cheryl Cleason	H.B. Zachary Co.	972-267-0430	972-267-0435
12 CRISTINA J. TERREANA	H.B. Zachary Co.	972-267-0430	972-267-0435
13 Scott Hutchins	H.B.Z.	972-267-0430	972-267-0435
14 Paddy Quatley Jr.	H.B.Z. Co.	972-267-0430	972-267-0435
15 Johnnie Cashtree	H.B. Zachary	972-267-0430	972-267-0435
16 Mervyn Limmon	H.B. Zachary	972-267-0430	972-267-0435
17 Michael V. Mowery	Austin Bridge & Road	972-241-2783	972-241-3369
18 CURTIS H. GRAY	F.A.A. ADDISON TOWER	972-490-4750	972-490-7324
19			
20			

SIGN-IN SHEET

PRECONSTRUCTION CONFERENCE

ADDISON AIRPORT
WEST TAXIWAY AND CONNECTORS WITH DRAINAGE IMPROVEMENTS
TxDOT PROJECT NO. 946 ADDR

Friday, April 3, 1998
10:30 a.m.

NAME	ORGANIZATION	TELEPHONE	FAX
1 Sam Stewart	ART	972-248-7733	972-248-2416
2 ZANE BRYAN		✓ 105	✓
3 Joe Scott	Austin Bridge & Road	817	
4 Tim Conson	Austin Bridge & Road	972-241-0699	972-241-3831
5 Brian Argent	Austin Bridge & Road		
6 Doug Best	Austin Bridge & Road	972-241-0699	
7 Honey Lujan	Utter Center-Const. Inc.	903-389-7404	Same
8			
9			
10			
11			
12			
13			
14			
15			
16			
17			
18			
19			
20			

facsimile
TRANSMITTAL

to: Zane Ryan / AATI
fax #: (972) 248-2416
re: Addison - West Taxiway
date: April 9, 1998
pages: 2, including this cover sheet.

The contractor for the West Taxiway project, H. B. Zachry, has asked if it would be possible to obtain access to the north end of Taxiway B via Dooley Road. Attached is a layout of the area (Sheet 5 from the plans) which shows an approximate location of Zachry's fence associated with the tunnel project, and the general area where they would like to install a gate.

If it is feasible to put an access gate in this general location, then Zachry will construct a haul road from that point over to Taxiway B. This would reduce the number of delivery trucks driving on Taxiway B.

Please give me a call at (817) 545-0891 to let me know if this is feasible, and whether there are any other potential access points that may also be used (e.g. Richard Byrd Dr.).

Leslie Sagar

cc: Jim Pierce

From the desk of...

Leslie V. Sagar, P.E.
Project Manager
URS GREINER, INC.
4100 Amon Carter Blvd., Suite 108
Fort Worth, Texas 76155

(817) 545-0891
Fax: (817) 545-0534

PHASES II AND III
 5' ACP BY 30' WIDE TEMPORARY DRIVEWAY CONNECTION.
 CONNECTION SHALL BE REMOVED UPON COMPLETION OF PHASES
 I AND III AND THE AREA RESTORED TO ITS PREVIOUS CONDITION.
 COST SHALL NOT BE PAID DIRECTLY, BUT WILL BE CONSIDERED
 SUBSIDIARY TO THE VARIOUS BID ITEMS.
 A PROPERLY TRAINED WINGWALKER OR FLAGMAN SHALL BE STATIONED
 AT THIS LOCATION DURING WORKING HOURS TO ASSIST AIRCRAFT
 IN TAXIING THROUGH THE AREA SAFELY.

PHASE I
 TEMPORARY CONNECTION FOR TOWED AIRCRAFT ONLY.
 25' WIDE DRIVEWAY CONNECTION SHALL BE CONSTRUCTED
 OF BASE COURSE AND SURFACE MATERIAL SALVAGED FROM
 THE EXISTING TAXIWAY PAVEMENT.
 CONNECTION SHALL BE REMOVED UPON COMPLETION OF
 PHASE I AND THE AREA RESTORED TO ITS PREVIOUS
 CONDITION.
 COST SHALL NOT BE PAID DIRECTLY, BUT
 WILL BE CONSIDERED SUBSIDIARY TO THE
 VARIOUS BID ITEMS.

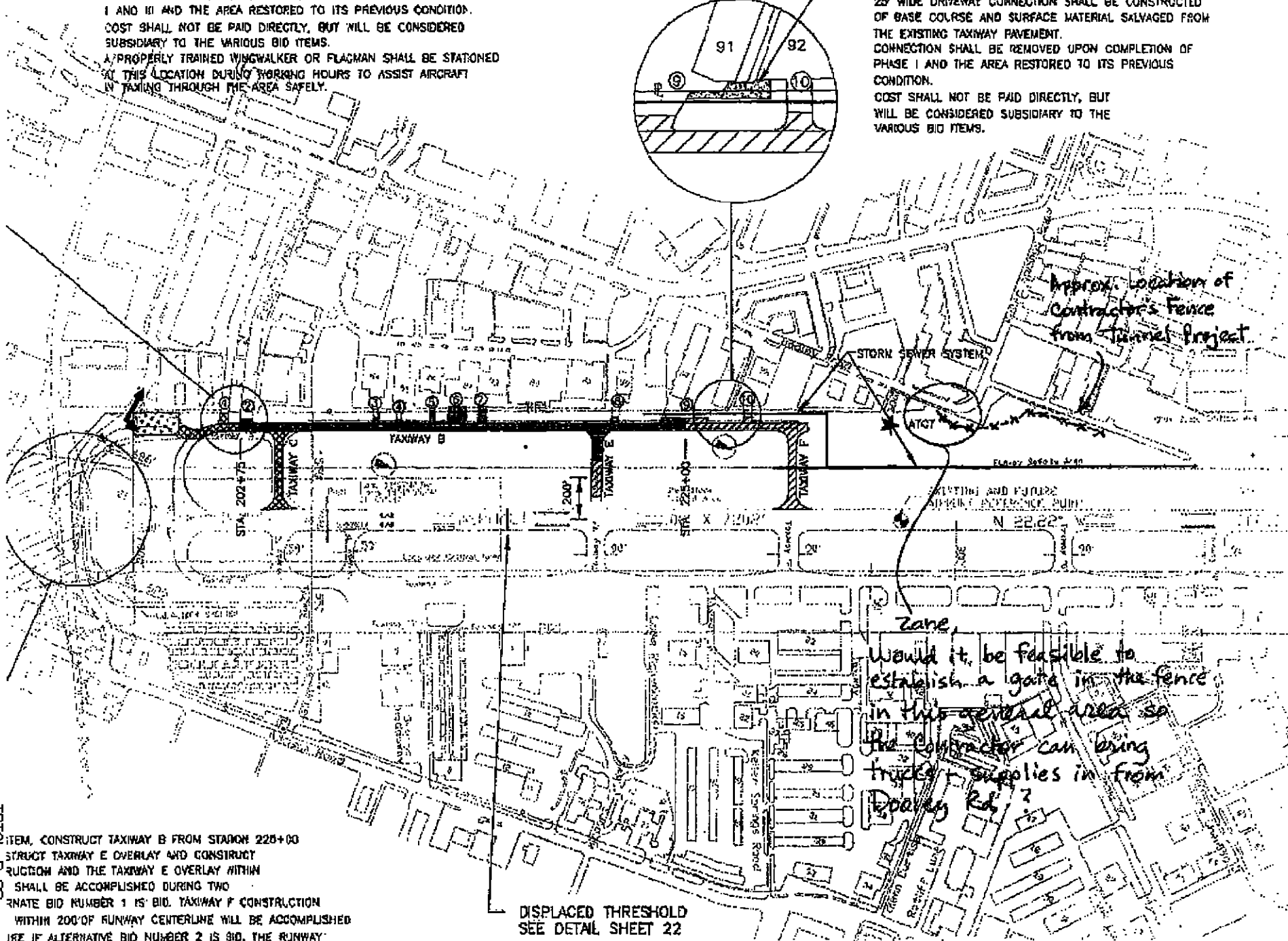
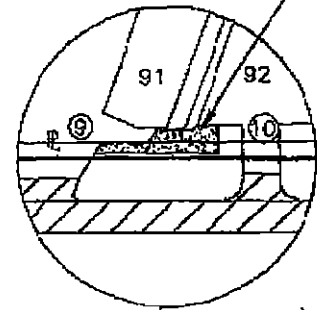

Zone
 Would it be feasible to
 establish a gate in the fence
 in this general area so
 the contractor can bring
 truck supplies in from
 Dairy Rd?

TOTAL P. 02
 ITEM, CONSTRUCT TAXIWAY B FROM STATION 228+00
 CONSTRUCT TAXIWAY E OVERLAY AND CONSTRUCT
 RUNWAY AND THE TAXIWAY E OVERLAY WITHIN
 SHALL BE ACCOMPLISHED DURING TWO
 BIDDING ALTERNATE BID NUMBER 1 IS BID. TAXIWAY F CONSTRUCTION
 WITHIN 200' OF RUNWAY CENTERLINE WILL BE ACCOMPLISHED
 DURING ALTERNATE BID NUMBER 2 IS BID. THE RUNWAY

DISPLACED THRESHOLD
 SEE DETAIL SHEET 22

James Pierce

From: Isagar@ursgreiner.com
Sent: Wednesday, April 08, 1998 10:08 AM
To: James Pierce
Subject: Re: Fax #



TELEPHON.WPD

Thanks for the revision. Attached is a wordperfect file with the revised list.

Also, I met yesterday with Jim Gardner of H B Zachry. He has a proposed idea on modifying the phasing plan which we are going to review. We also discussed potential pavement materials for the connectors that may reduce some construction time and we are going to look at some equivalent pavement sections. However, the real critical path appears to be completing the electrical work in the runway safety area.

I will keep you advised of our discussions.

Leslie (See attached file: TELEPHON.WPD)

TELEPHONE / ADDRESS LIST**ADDISON WEST TAXIWAY AND CONNECTORS
WITH DRAINAGE IMPROVEMENTS (SOUTH SEGMENT)**

		<u>Telephone</u>	<u>FAX</u>
<u>Texas Department of Transportation - Aviation Division</u>			
Bruce Ehly	Program Manager	(800) 687-4568	(512) 416-4510

Office Address:	Mailing Address:
200 E. Riverside Dr.	125 E. 11th Street
Austin, Tx 78704	Austin, TX 78701-2438

Town of Addison

John Baumgartner, P.E.	City Engineer	(972) 450-2871	(972) 450-2837
Jim Pierce, Jr., P.E., DEE	Asst. City Engineer	(972) 450-2879	(972) 450-2834
Clyde Johnson	Purchasing Manager	(972) 450-7090	(972) 450-7096

16801 Westgrove Drive
P.O. Box 144
Addison, TX 75001

URS Greiner, Inc.

Leslie Sagar, P.E.	Project Manager	(817) 545-0891	(817) 545-0534
Karen Griffin, P.E.	Project Engineer	(505) 345-3999	(505) 345-8393
Rick Tietgens, P.E.	Airport Engineer	(505) 345-3999	(505) 345-8393
Julian Wise, Sr.	Airport RPR	(972) _____	(972) _____

4100 Amon Carter Blvd., Suite 108
Fort Worth, TX 76155

5971 Jefferson Blvd, NE, Suite 101
Albuquerque, NM 87109

H.B. Zachry

Jim Gardner	Project Manager	(972) 267-0430	(972) 267-0435
Wayne Crabtree	Superintendent	(972) 267-0430	(972) 267-0435

Danny Gleason
Carlina Terrana
P.O. Box 1004
Addison, TX 75001-1004

A.A.T.I

Sam Stuart		(972) 248-7733x103	(972) 248-2416
Zane Ryan	Airport Ops	(972) 248-7733x105	(972) 248-2416

4/9/98

FAA Tower

Al Devane	Tower Chief	(972) 239-3725	(972) 490-4338
Curtis Gray		(972) 490-4750	(972) 490-7324

Maxim Technologies, Inc.

Larry Bracken	QA Testing	(214) 920-1885	(214) 920-1891
---------------	------------	----------------	----------------

2575 Lone Star Drive
P.O. Box 224227
Dallas, TX 75212

ADDISON AIRPORT

CONSTRUCT WEST TAXIWAY AND CONNECTORS WITH DRAINAGE IMPROVEMENTS
(SOUTH SEGMENT)

TXDOT PROJECT NO. 9248 ADDSN

PRECONSTRUCTION CONFERENCE

APRIL 3, 1998

AGENDA

1. INTRODUCTIONS

2. GENERAL ITEMS

- a. The scope of the project and the sequence and timing of all operations.
- b. Relationship of the resident engineer to the sponsor.
- c. Relationship between the FAA, TxDOT, and the sponsor.
- d. Relationship between A.A.T.I. and the sponsor. *Zane*
- e. Identification of the contractor's superintendent and a discussion of his/her authority and responsibilities. *Wayne Cuthrie Supt, Jim Gardner, Proj. mgr.*
- f. Designation of sponsor representative responsible for notifying the Flight Service Station serving the airport of the proposed start and completion dates of construction or of any circumstances requiring a NOTAM.

g. Scheduling of work and the need to perform certain items at various stages of the project, including operational safety problems which might arise because of the proposed work.

- h. Notice to proceed date. *Start 27th* *Begin Weekly*
- i. Insurance *comes with contract* *Sometimes Daily*
- j. Pay estimates *Monthly* *cut checks weekly* *Coordinating w Tower Daily*
- k. Staging area *cut off day 25th of month*
- l. Permits *Crane permit 30 days needed* *Get to Julian to Tom*
- m. Construction progress meetings *weekly initially*
- n. Field office *Thurs 10AM here* *Typ 10 days for Tom for pay*
Apr 23, 10AM here

3. SAFETY ITEMS

- a. Safety during construction, including the responsibility of marking and lighting of closed and hazardous areas.

*Need Training for
all Subs, Suppliers
Coord w Tower*

*Tower Hours
6-midnight
Look @ Haul Routes*

- b. Security requirements.
- c. Contractor must be alert to the following hazard-producing situations which may develop during the construction period.
 - (1) Open trenches and settlement of backfill adjacent to pavement.
 - (2) Pavement "drop offs" or "lips" at pavement tie-in areas.
 - (3) The obliteration, inadvertent relocation or disturbance of the marking and/or lighting of displaced threshold and marking of closed runways or taxiways.
 - (4) Damage to existing in-use pavement lighting, marking or NAVAIDS by construction forces.
 - (5) Spillage from vehicles on active airport pavement.
 - (6) Temporary stockpiling of material for an extended period of time.
 - (7) Contractor vehicular traffic through restricted critical areas of NAVAID facilities and the airport operating area.
 - (8) Dust control and environmental factors, such as burning, waste disposal, etc.
 - (9) Maintenance of sanitary facilities on the project site.

4. CONSTRUCTION ITEMS.

- a. Construction staking

monuments are in place - Contractor does own staking

*AOA = Active
Ops Area*

- b. Quality control and testing.

- (1) Who will do testing *Maxim*
- (2) What is to be tested *Concrete; Asphalt
Subgrade*
- (3) When testing is to take place
- (4) Location and number of tests

*Install a gate N. of Tower
for access*

- c. Discussion of Test Reports. Each report should, as a minimum, contain the following information.

- (1) Test performed.
- (2) Applicable standard.
- (3) Test location.
- (4) Test result.

Electrical Testing?

*Submit tests @ w/dts
pay requests*

(5) Action taken for failing tests.

A copy of all test reports should be furnished to the resident engineer in a timely manner. Failing test results should be reported to the resident engineer immediately. FAA/TxDOT is not obligated to financially participate in construction that does not meet contract plans and specifications.



d. Discussion of periodic construction report, Construction Progress and Inspection Report (FAA Form 5370-1).

e. Shop drawings *copies to VRS/G w copy to RAR*

f. Change orders, time extensions, periodic cost estimates, and liquidated damages.

5. LABOR REQUIREMENTS.

- a. Minimum wage rates.
- b. Employee classification and payrolls.
- c. Review of payrolls by sponsor.

6. CIVIL RIGHTS REQUIREMENTS.

7. SPECIAL ISSUES

- a. Runway closures
- b. Tenant Access

8. OTHER ISSUES

P:\DOCS\PRECOMP\PRECON.WPD

*10:30 PM to 6:30 AM closures
Some staging could take place earlier*

*ILS } Shutdowns
Oxidize } off Phase 2 & 3*

*33' Tractor - 6 months
localizer off Phase 3
when thresholds displaced*

SIGN-IN SHEET

PRECONSTRUCTION CONFERENCE

ADDISON AIRPORT
WEST TAXIWAY AND CONNECTORS WITH DRAINAGE IMPROVEMENTS
TXDOT PROJECT NO. 9248 ADDSN

Friday, April 3, 1998
10:30 a.m.

NAME	ORGANIZATION	TELEPHONE	FAX
1 Leslie Sagar	URS Greiner - Ft. Worth	(817) 545-0891	(817) 545-0534
2 Karen Griffin	URS Greiner - ABQ	(505) 345-3999	(505) 345-8393
3 Rick Tietgens	URS Greiner - ABQ	(505) 345-3999	(505) 345-8393
4 Jim Pierce	Town of Addison	972-450-2879	972-450-2834
5 Julian R. Wise	Wise Contractors Consultants Inc	903-389-7404	903-389-7404
6 Larry Bracke	Maxim Technologies	214-920-1885	214-920-1891
7 Charlotte BERGFELD	TXDOT, AVIATION	1-800-687-4568	512-416-4510
8 John Baumgart	Town of Addison	972-450-2871	972-450-2837
9 BRUCE EHLT	TXDOT AVIATION	1-800-687-4568	512-416-4510
10 SIM GARDNER	H.B. ZACHRY CO.	972-267-0430	972-267-0435
11 DANNY GLASSON	H.B. Zachary Co.	972-267-0430	972-267-0435
12 CARLINA J. TERRANA	H.B. Zachary Co.	972-267-0430	972-267-0435
13 Scott Hutchins	H.B.Z.	972-262-8898	972-264-5597
14 Bobby Painter, Sr	H.B.Z. Co.	972-262-0430	972-267-0435
15 Wayne Crabtree	H.B. Zachary	972-267-0430	972-267-0435
16 Majed Limam	H.B. Zachary	972-267-0430	972-267-0435
17 Mitchell V. Mowery	Austin Bridge & Road	972-241-2783	972-241-3369
18 CURTIS H. GRAY	F.A.A. ADDISON TOWER	972-490-4750	972-490-7324
19			
20			

SIGN-IN SHEET

PRECONSTRUCTION CONFERENCE

ADDISON AIRPORT
WEST TAXIWAY AND CONNECTORS WITH DRAINAGE IMPROVEMENTS
TXDOT PROJECT NO. 9248 ADDSN

Friday, April 3, 1998
10:30 a.m.

	NAME	ORGANIZATION	TELEPHONE	FAX
1	SAM STUART	AATI	972-248-7733 ^{EXT} 103	972-248-2416
2	ZANE RYAN	✓	✓ 105	✓
3	Joe Scott	Austin Bridge & Road	817	—————
4	Tim Creson	Austin Bridge & Road	972-241-0699	972-241-3831
5	Brian Arent	Austin Bridge & Road		
6	Doug Best	Austin Bridge + Road	972-241-0699	
7	Nancy Wise	Wise Contrs.-Consts. Inc	903-389-7404	Same
8				
9				
10				
11				
12				
13				
14				
15				
16				
17				
18				
19				
20				

TEXAS DEPARTMENT OF TRANSPORTATION - DIVISION OF AVIATION
Grant Payment Request Form (Reliever Airports)

SECTION A (TO BE COMPLETED BY TXDOT)

Name of Payee _____ City of Addison _____
Texas Payee Identification Number 17513335558005 (Direct Deposit)
Address _____ P.O. Box 699 _____
City, State Zip Code Addison, Texas 75001
Airport: _____ Addison _____
Segment 76 Dist/Div 42 Function Code 874 Object Code 384
TxDOT CSJ : _____ TxDOT Contract No. _____
Date Received: _____ Eligible for Federal Reimbursement Yes No
Current Grant Amount(Grant Management) \$ _____
Less Previous Approved Payments(Grant Management) \$ _____
AMOUNT APPROVED THIS PAYMENT \$ _____
APPROVAL:
Grant Manager _____ Date _____

SECTION B: [COMPLETED BY SPONSOR]

DATE OF REQUEST: _____

Classifications of Costs For This Pay Request

Construction	\$ _____
Engineering	\$ _____
Administrative	\$ _____
Cumulative Costs Incurred to Date	\$ _____
Less 10% Sponsor Share	\$ _____
Total Cost to be Reimbursed	\$ _____
Amount Previously Requested	\$ _____
AMOUNT OF THIS PAYMENT REQUEST	\$ _____

ATTACH COPY OF INVOICES TO THIS REQUEST

CERTIFICATION OF SPONSOR

I, _____, do hereby certify that I am _____,
(Title of person certifying)

and that I am duly authorized to make this certification for and on behalf of the City of Addison. I further certify that the attached invoice is correct and that it corresponds in every particular with the supplies and/or services contracted for. I further certify that the account is true, correct, and unpaid.

SIGNATURE

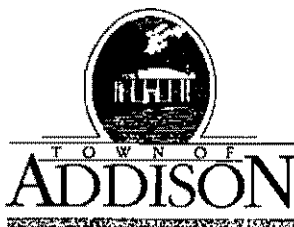

FINANCE DEPARTMENT / PURCHASING DIVISION

5350 Belt Line Road

(214) 450-7091 · Facsimile (214) 386-0938

Post Office Box 144 Addison, Texas 75001

CLYDE JOHNSON, C.P.M.
PURCHASING MANAGER

New Facsimile (972) 450-7096

Phone (972) 450-7090

April 6, 1998

Mr. Brian Salerno
H.B. Zachry Company
P.O. Box 531558
Grand Prairie, TX 75053-1558

Post-it® Fax Note	7671	Date	4-8-98	# of pages	1
To	Leslie Sagar	From	Jim Pierce		
Co./Dept.	URS/Greiner	Co.	Addison		
Phone #		Phone #			
Fax #	1-817-545-0534	Fax #			

NOTICE OF AWARD: Construct West Taxiway and Connectors with Drainage Improvements (South Segment) Addison Airport.

Dear Mr. Salerno:

Receipt of this document authorizes your company to provide all labor and materials as outlined in the specifications, and under the terms and conditions of the contract documents for Bid No: 98-04. The City Council authorized the expenditure of the \$2,050,628.05, the concrete alternate with taxiway lighting alternate.

Enclosed please find three completed copies of the contract to be signed by an authorized officer or principal of your firm.

Please return all three copies, along with the necessary bonds and insurance certificates, as soon as possible, but no later than April 17, 1998.

If you have any questions or if I can be of assistance to you, please contact me at 972-450-7090.

Sincerely,

Clyde Johnson

Enclosures

Copy: John Baumgartner

*Package hand delivered
to Wayne Outtree @
Dooley Rd Trailer
4-6-98*

FAX TRANSMISSION

TXDOT - AVIATION DIVISION
125 E. 11TH STREET
AUSTIN, TEXAS 78701-2483
(512) 416-4522 1-800-687-4568
FAX: (512) 416-4510

To: John Baumgartner
Public Works Director

Date: April 2, 1998

Fax #: (972) 450-2834

Pages: 2, including this cover sheet.

From: Kathy Griffin

Subject: Notice To Proceed letter for executed Grant.

COMMENTS:

I will mail the original with your copy of the executed grant agreement and payment request form.
Please call me if you need additional information concerning the grant or payment process.

Thanks,



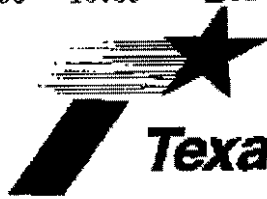

Texas Department of Transportation

AVIATION DIVISION

125 E. 11TH STREET • AUSTIN, TEXAS 78701-2463 • 512/416-4500 • FAX 512/416-4510

April 2, 1998

Mr. John Baumgarter
Public Works Director, City of Addison
P.O. Box 9010
Addison, Texas 75001-9010

RE: TxDOT CSJ No. 9842ADDSN

Dear Mr. Baumgarter:

We are pleased to return to you the completed Airport Project Participation Agreement between the City of Addison and the Texas Department of Transportation. By receipt of this letter a notice to proceed for the construction is issued effective April 2, 1998.

The Grant Management section will handle payments for work performed on this grant. I will be available to answer questions you may have about the status of your payments. Enclosed is a copy of the Grant Payment Request Form to be used when requesting reimbursement. This form is available in "Word" format and I would be happy to provide this on diskette or send it by the Internet.

We look forward to the successful completion of this important project. Please call us for any data you desire at 1-800-687-4568 (800-68-PILOT).

Sincerely,

Kathy Griffin
Grant Manager

cc: Mr. Andrew Velayos, FAA
Mr. Bruce Ehly

Called
for Email
4-6-98

Leslie

✓ CAD Devg. to HBZ

✓ Pre const meet charge date

One weekend shutdown
Scenario

✓ Inspector Status
- still working on this -

www.NWRS.com



HOTEL ADOLPHUS

A NOBLE HOUSE HOTEL

1321 COMMERCE, DALLAS, TEXAS 75202

(214) 742-8200

URS Greiner

URS Greiner, Inc.
4100 Amon Carter Boulevard, Suite 108
Fort Worth, Texas 76155
Telephone: (817) 545-0891
Facsimile: (817) 545-0534
Offices in Principal Cities Nationwide

March 31, 1998
E708024.81

Mr. Wayne Crabtree
H. B. Zachry
P. O. Box 1004
Addison, Texas 75001-1004

**Re: West Taxiway and Connectors with Drainage Improvements (South Segment)
Addison Airport**

Dear Mr. Crabtree:

Transmitted herewith for your information and use is an electronic file of the plans for the above referenced project. The files are in AutoCadd Version 12.

I look forward to meeting you on Friday, April 3, at the pre-construction conference.

Sincerely,

URS GREINER, INC.



Leslie V. Sagar, P.E.
Project Manager

encl.



TOWN OF
ADDISON

PUBLIC WORKS

To: Jim Gardner

From: James C. Pierce, Jr., P.E., DEE

Company: H. B. Zachry

Assistant City Engineer

Phone: 972/450-2879

FAX #: 267-0435

FAX: 972/450-2834

Date: 3-26-98

16801 Westgrove

P.O. Box 144

Re: Westside Taxiway

Addison, TX 75001

of pages (including cover): 1

Original in mail

Per your request

FYI

Call me

Comments:

For the record, Council has authorized
the City Manager to award the contract
using the concrete alternate and
the lighting alternate.

As mentioned before, award is subject
to receipt of the FAA Grant.

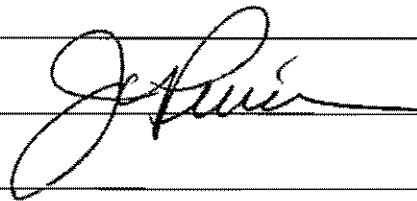

MODE = TRANSMISSION

START=03-26 01:37PM

END=03-26 01:38PM

NO.	COM	SPEED NO	STATION NAME/ TELEPHONE NO.	PAGES
-----	-----	----------	--------------------------------	-------

001	OK	2	92670435	001
-----	----	---	----------	-----

-Addison Svc Ctr -Upstairs-

***** (FAX-200 U2.17)* - 972 450 2834- *****

facsimile
TRANSMITTAL

to: Distribution:
Wayne Crabtree / H. B. Zachry
John Baumgartner / Town of Addison
Jim Pierce / Town of Addison
Clyde Johnson / Town of Addison
Bruce Ehly / TXDOT- Aviation
Curt Horn / A. A. T. I.
Al Devane / FAA Tower Chief
Karen Griffin / URS Greiner
Rick Tietgens / URS Greiner
Julian Wise, Sr. / Wise Contractors-Consultants, Inc.
Larry Bracken / Maxim Technologies, Inc.

fax #:

re: Addison Airport West Taxiway and Connectors with Drainage Improvements (South Segment) Pre-Construction Meeting

date: March 24, 1998

pages: 4, including this cover sheet.

Please be advised that a Pre-Construction meeting will be held for the above referenced project at the Addison Airport on Friday, April 3, 1998 at 10:30 a.m. The meeting will be held at the Addison Service Center at 16801 Westgrove, Addison, Texas. The purpose of the meeting is to discuss variety of issues including project sequencing, safety and security requirements, quality control testing, and wage rates. A copy of the draft agenda for the meeting is attached for your review.

If you are unable to attend this important meeting, please contact me at (817) 545-0891.



From the desk of...

Leslie V. Sagar, P.E.
Project Manager
URS GREINER, INC.
4100 Amon Carter Blvd., Suite 108
Fort Worth, Texas 76155

(817) 545-0891
Fax: (817) 545-0534

TOWN OF ADDISON**CONSTRUCT WEST TAXIWAY AND CONNECTORS WITH DRAINAGE IMPROVEMENTS
(SOUTH SEGMENT)****PRECONSTRUCTION CONFERENCE****APRIL 3, 1998****DRAFT AGENDA****1. INTRODUCTIONS****2. GENERAL ITEMS**

- a. The scope of the project and the sequence and timing of all operations.
- b. Relationship of the resident engineer to the sponsor.
- c. Relationship between the FAA, TXDOT, and the sponsor.
- d. Relationship between A.A.T.I and the sponsor.
- e. Identification of the contractor's superintendent and a discussion of his/her authority and responsibilities.
- f. Designation of sponsor representative responsible for notifying the Flight Service Station serving the airport of the proposed start and completion dates of construction or of any circumstances requiring a NOTAM.
- g. Scheduling of work and the need to perform certain items at various stages of the project, including operational safety problems which might arise because of the proposed work.
- h. Notice to proceed date.
- i. Insurance
- j. Pay estimates
- k. Staging area
- l. Permits
- m. Construction progress meetings
- n. Field office

3. SAFETY ITEMS

- a. Safety during construction, including the responsibility of marking and lighting of closed and hazardous areas.

b. Security requirements.

c. Contractor must be alert to the following hazard-producing situations which may develop during the construction period.

(1) Open trenches and settlement of backfill adjacent to pavement.

(2) Pavement "drop offs" or "lips" at pavement tie-in areas.

(3) The obliteration, inadvertent relocation or disturbance of the marking and/or lighting of displaced threshold and marking of closed runways or taxiways.

(4) Damage to existing in-use pavement lighting, marking or NAVAIDS by construction forces.

(5) Spillage from vehicles on active airport pavement.

(6) Temporary stockpiling of material for an extended period of time.

(7) Contractor vehicular traffic through restricted critical areas of NAVAID facilities and the airport operating area.

(8) Dust control and environmental factors, such as burning, waste disposal, etc.

(9) Maintenance of sanitary facilities on the project site.

4. CONSTRUCTION ITEMS.

a. Construction staking

b. Quality control and testing.

(1) Who will do testing

(2) What is to be tested

(3) When testing is to take place

(4) Location and number of tests

c. Discussion of Test Reports. Each report should, as a minimum, contain the following information.

(1) Test performed.

(2) Applicable standard.

(3) Test location.

(4) Test result.

(5) Action taken for failing tests.

A copy of all test reports should be furnished to the resident engineer in a timely manner. Failing test results should be reported to the resident engineer immediately. FAA/TxDOT is not obligated to financially participate in construction that does not meet contract plans and specifications.

d. Discussion of periodic construction report, Construction Progress and Inspection Report (FAA Form 5370-1).

e. Shop drawings

f. Change orders, time extensions, periodic cost estimates, and liquidated damages.

5. LABOR REQUIREMENTS.

a. Minimum wage rates.

b. Employee classification and payrolls.

c. Review of payrolls by sponsor.

6. CIVIL RIGHTS REQUIREMENTS.

7. SPECIAL ISSUES

a. Runway closures

b. Tenant Access

8. OTHER ISSUES

P:\DOCS\PRECON VWP

FAX COVER SHEET

To: Jim Pierce
Firm: Town of Addison
Fax #:
From: Leslie Sager
Subject: West Taxiway

URS Greiner
 4100 Amon Carter Boulevard
 Suite 108
 Fort Worth, TX 76155-2602
 Telephone: (817) 545-0891
 Fax: (817) 545-0534

Date: 3/24/98
Page 1 of: 5

Sorry for the delay - I never heard back from Curt Hearn but was able to get the Tower chief's name and number from Charles Carroll at the FAA.

Attached is the fax memo I plan to send out along with the draft agenda. If you have no comments I will send this out today.

Leslie Sager

cc:

facsimile
TRANSMITTAL

to: Distribution:
Wayne Crabtree / H. B. Zachry
Jim Pierce / Town of Addison
Clyde Johnson / Town of Addison
Bruce Ehly / TxDOT- Aviation
Curt Horn / A. A. T. I.
Al Devane / FAA Tower Chief
Karen Griffin / URS Greiner
Rick Tietgens / URS Greiner
Julian Wise, Sr. / Wise Contractors-Consultants, Inc.
Larry Braxton / Maxim Technologies, Inc.

fax #:
re: Addison Airport West Taxiway and Connectors with Drainage Improvements (South Segment) Pre-Construction Meeting
date: March 24, 1998
pages: 4, including this cover sheet.

Please be advised that a Pre-Construction meeting will be held for the above referenced project at the Addison Airport on Friday, April 3, 1998 at 10:30 a.m. The meeting will be held at the Addison Service Center at 16801 Westgrove, Addison, Texas. The purpose of the meeting is to discuss variety of issues including project sequencing, safety and security requirements, quality control testing, and wage rates. A copy of the draft agenda for the meeting is attached for your review.

If you are unable to attend this important meeting, please contact me at (817) 545-0891.

From the desk of..

Leslie V. Sagar, P.E.
Project Manager
URS GREINER, INC.
4100 Amon Carter Blvd., Suite 108
Fort Worth, Texas 76155

(817) 545-0891
Fax: (817) 545-0634

TOWN OF ADDISON**CONSTRUCT WEST TAXIWAY AND CONNECTORS WITH DRAINAGE
IMPROVEMENTS (SOUTH SEGMENT)****PRECONSTRUCTION CONFERENCE
APRIL 3, 1998
AGENDA****1. INTRODUCTIONS****2. GENERAL INTEREST**

- a. The scope of the project and the sequence and timing of all operations.
- b. Relationship of the resident engineer to the sponsor.
- c. Relationship between the FAA, TxDOT, and the sponsor.
- d. Identification of the contractor's superintendent and a discussion of his/her authority and responsibilities.
- e. Designation of sponsor representative responsible for notifying the Flight Service Station serving the airport of the proposed start and completion dates of construction or of any circumstances requiring a NOTAM.
- f. Scheduling of work and the need to perform certain items at various stages of the project, including operational safety problems which might arise because of the proposed work.
- g. Notice to proceed date.

3. SAFETY ITEMS

- a. Safety during construction, including the responsibility of marking and lighting of closed and hazardous areas.
- b. Security requirements.
- c. Contractor must be alert to the following hazard-producing situations which may develop during the construction period.
 - (1) Open trenches and settlement of backfill adjacent to pavement.
 - (2) Pavement "drop offs" or "lips" at pavement tie-in areas.

(3) The obliteration, inadvertent relocation or disturbance of the marking and/or lighting of displaced threshold and marking of closed runways or taxiways.

(4) Damage to existing in-use pavement lighting, marking or NAVAIDS by construction forces.

(5) Spillage from vehicles on active airport pavement.

(6) Temporary stockpiling of material for an extended period of time.

(7) Contractor vehicular traffic through restricted critical areas of NAVAID facilities and the airport operating area.

(8) Dust control and environmental factors, such as burning, waste disposal, etc.

(9) Maintenance of sanitary facilities on the project site.

4. CONSTRUCTION ITEMS.

a. Quality control and testing.

(1) Who will do testing

(2) What is to be tested

(3) When testing is to take place

(4) Location and number of tests

b. Discussion of Test Reports. Each report should, as a minimum, contain the following information.

(1) Test performed.

(2) Applicable standard.

(3) Test location.

(4) Test result.

(5) Action taken for failing tests.

A copy of all test reports should be furnished to the resident engineer in a timely manner. Failing test results should be reported to the resident engineer immediately.

FAA/TxDOT is not obligated to financially participate in construction that does not meet contract plans and specifications.

c. Discussion of periodic construction report, Construction Progress and Inspection Report (FAA Form 5370-1).

d. Change orders, time extensions, periodic cost estimates, and liquidated damages.

5. LABOR REQUIREMENTS.

- a. Minimum wage rates.
- b. Employee classification and payrolls.
- c. Review of payrolls by sponsor.

Post-it® Fax Note 7671		Date 3/24	# of pages 1
To Leslie Sagar	From Jim Pierce	Co. Addison	
Co./Dept. URS-G	Phone #	Fax #	
Phone #	Fax # 1-817-545-0534		

6. CIVIL RIGHTS REQUIREMENTS.

7. SPECIAL ISSUES

- a. Runway closures

8. OTHER ISSUES

P:\DOCS\PRECON.WPD

Add John Baumgartner to Distribution

Cover: Insurance
~~Sequencing~~ Tenant Access
 Construction Progress meetings
 Construction Staking
 Pay Estimates/charge Orders
 Shop Drawings
 Permits
 Field Office

Staging Area

MODE = TRANSMISSION

START=03-24 02:44PM

END=03-24 02:48PM

NO.	COM	SPEED NO	STATION NAME/ TELEPHONE NO.	PAGES
001	OK	#	918175450534	001

-Addison Svc Ctr -Upstairs-

***** (FAX-200 U2.17)* - 972 450 2834- *****

3-18-98

Taxiway F

Crushed aggregate & Lime-treated subbase
 $400' \text{ long} \times 37' \text{ wide} \times \frac{15'' \text{ deep}}{12} = 18,500 \text{ ft}^3$
or 685 yd^3

$$685 \text{ yd}^3 \times \$73.44 = \$50,320$$

Equivalent concrete

$$685 \text{ yd}^3 \times \$109 = \frac{74,665}{\$24,345 \text{ additional}}$$

3-18-98

Lime Treated Subgrade \$ 2.56 / yd² (9" thick)

Lime \$ 138.61 / ton

applied to result in 6% lime, dry wt basis

$$\text{Cost of LTSG} = \frac{\$ 2.56 \text{ yd}^2}{0.25 \text{ yd}^3 \text{ yd}^2} = \$ 10.24 / \text{yd}^3$$

$$+ \frac{16.12}{\$ 26.36 / \text{yd}^3}$$

Crushed Agg Base Course 47.08 / yd³

\$ 73.44 / yd³

10" Port. Cement Concrete Pavement \$ 30.32 / yd²

1 yd² of 10" concrete pavement =

$$9 \text{ ft}^2 \times \frac{10'}{12} = 7.5 \text{ ft}^3$$

$$\frac{\$ 30.32}{7.5 \text{ ft}^3} \times \frac{27 \text{ ft}^3}{\text{yd}^3} = \$ 109 / \text{yd}^3$$

\$ 35.56 / yd³
difference

assume dry wt soil = $\frac{100 \text{ lb}}{\text{ft}^3}$

6% lime, dry wt basis = 6 lbs lime req'd.

$\frac{6 \text{ lbs lime}}{0.7}$ (70% lime) = 8.6 lbs dry lime must be added per ft³ of soil

$$1 \text{ yd}^2 = 9 \text{ ft}^2 \times \frac{9''}{12''} = 6.75 \text{ ft}^3 \text{ or } 0.25 \frac{\text{yd}^3}{\text{yd}^2}$$

232 lbs lime must be added / yd³

$$232 \text{ lbs} \times \frac{\$ 139}{\text{ton } 2000 \text{ lb}} = \$ 16.12 / \text{yd}^3$$

Lime Treated Subgrade

$$\$ 2.56 / \text{yd}^2 \quad (9" \text{ thick})$$

$$1 \text{ sq yd} = 9 \text{ ft}^2 \times \frac{9}{12} = 6.75 \text{ ft}^3$$

$$\frac{6.75 \text{ ft}^3}{27 \text{ ft}^3} \text{ yd}^3 = 0.25 \text{ yd}^3$$

Lime Treated Subgrade costs

$$\frac{\$ 2.56}{0.25 \text{ yd}^3} = \$ 10.24 / \text{yd}^3$$

Lime

Assume dry wt of soil = 100 lb / ft³

6% lime reqd on dry wt basis

Lime is 70% pure

$$100 \text{ lb} \times 0.06 = 6 \text{ lb pure lime reqd}$$

$$\frac{6 \text{ lb}}{0.7} = 8.57 \text{ lb actual lime reqd.}$$

8.57 lb reqd / ft³ soil

$$8.57 \frac{\text{lb}}{\text{ft}^3} \times \frac{27 \text{ ft}^3}{\text{yd}^3} = 231.4 \text{ lb lime reqd} / \text{yd}^3$$

$$\frac{231.4 \text{ lb}}{2000 \text{ lb}} \times \frac{\$ 139}{\text{ton}} = \$ 16.08 / \text{yd}^3$$

lime cost

James Pierce

From: James Pierce
Sent: Tuesday, March 17, 1998 1:44 PM
To: Leslie Sagar (E-mail)
Subject: Westside Taxiway

Have not seen your preconstruction meeting notice yet. Also, contractor has asked for an electronic file of the plans-AutoCad. Can you furnish?
Jim.

TOWN OF
ADDISON

PUBLIC WORKS

To: Leslie Sagar

From: James C. Pierce, Jr., P.E., DEE

Company: URS-Greiner

Assistant City Engineer

Phone: 972/450-2879

FAX #: 817-545-0534

FAX: 972/450-2834

Date: 3-7-98

16801 Westgrove

P.O. Box 144

Addison, TX 75001

Re: Westside Taxiway

of pages (including cover): 1

*Confirmed
re: report by
telephone*

Original in mail

Per your request

FYI

Call me

Comments:

We would like to schedule a pre construction meeting for 10AM, Friday, April 3rd. Please notify all attendees in writing of the meeting: Jim Gardner/Zachry, AATI/Kurt Horn, FAA including the Tower Chief, Clyde Johnson/Purchasing, and any others appropriate - oh yes - Bruce Ehly TxDot Aviation. We should be receiving our grant any day now. We will probably issue a notice to proceed for April 6, 1998. We will need your inspector as soon as activities start. Also, you "owe" me some pavement redesign in that one area we talked about earlier. Please call.

Jim

***** -COMM. JOURNAL- ***** DATE 03-06-1998 TIME 04:42PM ** P.1

MODE = TRANSMISSION

START=03-06 04:41PM

END=03-06 04:42PM

NO.	COM	SPEED NO	STATION NAME/ TELEPHONE NO.	PAGES
-----	-----	----------	--------------------------------	-------

001	OK	5	918175450534	001
-----	----	---	--------------	-----

-Addison Svc Ctr -Upstairs-

***** (FAX-200 V2.17)* - 972 450 2834- *****

GLRTB4 : GENERAL LEDGER CAPITAL PROJECT REPORT FISCAL YEAR 1995

FND : 12 AIRPORT FUND

Fn	Dpt	Acct	Proj	Sec Title	Revised Budget	Current Month Expenditures	Year-to-date Expenditures	% of Budget Expended
12	000	43110	44200	000 FAA GRANT	-1,400,000.00	-692,739.66	-692,739.66	49.5
12	625	56080	44200	000 ADVERTISING	0.00	0.00	0.00	0.0
12	625	56510	44200	000 AUDIT AND LEGAL SERV	1,500.00	2,000.00	2,000.00	133.3
12	625	56570	44200	000 ENGINEERING/ARCHITEC	50,000.00	70,884.05	70,884.05	141.8
12	625	58210	44200	000 STREETS AND ALLEYS	1,504,000.00	696,826.53	696,826.53	46.3
12	***	*****	44200	*** 1994 AIRPORT IMPROVE	155,500.00	76,970.92	76,970.92	49.5
12	000	43110	54200	000 FAA GRANT	0.00	0.00	0.00	0.0
12	625	56080	54200	000 ADVERTISING	0.00	482.40	482.40	0.0
12	625	56510	54200	000 AUDIT AND LEGAL SERV	0.00	0.00	0.00	0.0
12	625	56570	54200	000 ENGINEERING/ARCHITEC	0.00	144,751.20	144,751.20	0.0
12	625	58110	54200	000 LAND PURCHASE	0.00	0.00	0.00	0.0
12	625	58210	54200	000 STREETS AND ALLEYS	0.00	0.00	0.00	0.0
12	***	*****	54200	*** WEST TAXIWAY RECON 1	0.00	145,233.60	145,233.60	0.0
12	000	43110	54201	000 FAA GRANT	0.00	0.00	0.00	0.0
12	000	44211	54201	000 FAA GRANT	0.00	0.00	0.00	0.0
12	621	56570	54201	000 ENGINEERING/ARCHITEC	0.00	0.00	0.00	0.0
12	625	56510	54201	000 AUDIT AND LEGAL SERV	0.00	0.00	0.00	0.0
12	625	56570	54201	000 ENGINEERING/ARCHITEC	0.00	2,810.00	2,810.00	0.0
12	***	*****	54201	*** AIRPORT MASTER PLAN	0.00	2,810.00	2,810.00	0.0
2	000	43540	64300	000 TEXAS TURNPIKE AUTHO	0.00	0.00	0.00	0.0
2	000	49320	64300	000 G. O. BOND PROCEEDS	0.00	0.00	0.00	0.0
2	623	54270	64300	000 SIGNAL SYSTEMS/STREE	0.00	0.00	0.00	0.0
2	623	56040	64300	000 SPECIAL SERVICES	0.00	0.00	0.00	0.0
2	623	56180	64300	000 RENTAL	0.00	0.00	0.00	0.0
2	623	56510	64300	000 AUDIT AND LEGAL SERV	0.00	0.00	0.00	0.0
2	623	56570	64300	000 ENGINEERING/ARCHITEC	0.00	0.00	0.00	0.0
2	623	58110	64300	000 LAND PURCHASE	0.00	0.00	0.00	0.0
2	623	58910	64300	000 BUILDINGS	0.00	0.00	0.00	0.0
2	***	*****	64300	*** KELLER SPRINGS TOLL	0.00	0.00	0.00	0.0
2	621	56040	74100	000 SPECIAL SERVICES	0.00	0.00	0.00	0.0
2	621	56080	74100	000 ADVERTISING	0.00	0.00	0.00	0.0
2	621	56570	74100	000 ENGINEERING/ARCHITEC	0.00	0.00	0.00	0.0
2	***	*****	74100	*** 2001 AIRPORT PROJECT	0.00	0.00	0.00	0.0

GLRTB4 : GENERAL LEDGER CAPITAL PROJECT REPORT FISCALYEAR 1996

FND : 12 AIRPORT FUND

Fn Dpt Acct Proj Sec Title	Revised Budget	Current Month Expenditures	Year-to-date Expenditures	% of Budget Expended
12 000 43110 44200 000 FAA GRANT	0.00	0.00	0.00	0.0
12 625 56080 44200 000 ADVERTISING	0.00	0.00	0.00	0.0
12 625 56510 44200 000 AUDIT AND LEGAL SERV	1,000.00	0.00	0.00	0.0
12 625 56570 44200 000 ENGINEERING/ARCHITEC	0.00	0.00	0.00	0.0
12 625 58210 44200 000 STREETS AND ALLEYS	0.00	0.00	0.00	0.0
12 *** ***** 44200 *** 1994 AIRPORT IMPROVE	1,000.00	0.00	0.00	0.0
12 000 43110 54200 000 FAA GRANT	-1,862,100.00	0.00	0.00	0.0
12 625 56080 54200 000 ADVERTISING	0.00	0.00	0.00	0.0
12 625 56510 54200 000 AUDIT AND LEGAL SERV	1,000.00	0.00	0.00	0.0
12 625 56570 54200 000 ENGINEERING/ARCHITEC	25,000.00	2,100.56	2,100.56	8.4
12 625 58110 54200 000 LAND PURCHASE	0.00	0.00	0.00	0.0
12 625 58210 54200 000 STREETS AND ALLEYS	2,045,000.00	0.00	0.00	0.0
12 *** ***** 54200 *** WEST TAXIWAY RECON 1	208,900.00	2,100.56	2,100.56	1.0
12 000 43110 54201 000 FAA GRANT	-135,000.00	-75,323.00	-75,323.00	55.8
12 000 44211 54201 000 FAA GRANT	0.00	0.00	0.00	0.0
12 621 56570 54201 000 ENGINEERING/ARCHITEC	0.00	0.00	0.00	0.0
12 625 56510 54201 000 AUDIT AND LEGAL SERV	0.00	1,000.00	1,000.00	0.0
12 625 56570 54201 000 ENGINEERING/ARCHITEC	147,000.00	83,994.16	83,994.16	57.1
12 *** ***** 54201 *** AIRPORT MASTER PLAN	12,000.00	9,671.16	9,671.16	80.6
2 000 43540 64300 000 TEXAS TURNPIKE AUTHO	0.00	0.00	0.00	0.0
2 000 49320 64300 000 G. O. BOND PROCEEDS	0.00	0.00	0.00	0.0
2 623 54270 64300 000 SIGNAL SYSTEMS/STREE	0.00	0.00	0.00	0.0
2 623 56040 64300 000 SPECIAL SERVICES	0.00	10,700.00	10,700.00	0.0
2 623 56180 64300 000 RENTAL	0.00	0.00	0.00	0.0
2 623 56510 64300 000 AUDIT AND LEGAL SERV	0.00	7,170.00	7,170.00	0.0
2 623 56570 64300 000 ENGINEERING/ARCHITEC	0.00	4,704.32	4,704.32	0.0
2 623 58110 64300 000 LAND PURCHASE	0.00	4,637.50	4,637.50	0.0
2 623 58910 64300 000 BUILDINGS	0.00	0.00	0.00	0.0
2 *** ***** 64300 *** KELLER SPRINGS TOLL	0.00	27,211.82	27,211.82	0.0
2 621 56040 74100 000 SPECIAL SERVICES	0.00	0.00	0.00	0.0
2 621 56080 74100 000 ADVERTISING	0.00	0.00	0.00	0.0
2 621 56570 74100 000 ENGINEERING/ARCHITEC	0.00	0.00	0.00	0.0
! *** ***** 74100 *** 2001 AIRPORT PROJECT	0.00	0.00	0.00	0.0

GLRTB4 : GENERAL LEDGER CAPITAL PROJECT REPORT FISCAL YEAR 1997

FND : 12 AIRPORT FUND

Fn	Dpt	Acct	Proj	Sec Title	Revised Budget	Current Month Expenditures	Year-to-date Expenditures	% of Budget Expended
12	000	43110	44200	000 FAA GRANT	0.00	0.00	0.00	0.0
12	625	56080	44200	000 ADVERTISING	0.00	0.00	0.00	0.0
12	625	56510	44200	000 AUDIT AND LEGAL SERV	0.00	0.00	0.00	0.0
12	625	56570	44200	000 ENGINEERING/ARCHITEC	0.00	0.00	0.00	0.0
12	625	58210	44200	000 STREETS AND ALLEYS	0.00	0.00	0.00	0.0
12	***	*****	44200	*** 1994 AIRPORT IMPROVE	0.00	0.00	0.00	0.0
12	000	43110	54200	000 FAA GRANT	-450,000.00	0.00	0.00	0.0
12	625	56080	54200	000 ADVERTISING	0.00	0.00	0.00	0.0
12	625	56510	54200	000 AUDIT AND LEGAL SERV	0.00	0.00	0.00	0.0
12	625	56570	54200	000 ENGINEERING/ARCHITEC	0.00	810.22	810.22	0.0
12	625	58110	54200	000 LAND PURCHASE	500,000.00	0.00	0.00	0.0
12	625	58210	54200	000 STREETS AND ALLEYS	0.00	0.00	0.00	0.0
12	***	*****	54200	*** WEST TAXIMAY RECON 1	50,000.00	810.22	810.22	1.6
12	000	43110	54201	000 FAA GRANT	-35,000.00	-52,942.00	-52,942.00	151.3
12	000	44211	54201	000 FAA GRANT	0.00	0.00	0.00	0.0
12	621	56570	54201	000 ENGINEERING/ARCHITEC	0.00	0.00	0.00	0.0
12	625	56510	54201	000 AUDIT AND LEGAL SERV	0.00	4,600.00	4,600.00	0.0
12	625	56570	54201	000 ENGINEERING/ARCHITEC	40,000.00	60,329.00	60,329.00	150.8
2	***	*****	54201	*** AIRPORT MASTER PLAN	5,000.00	11,987.00	11,987.00	239.7
2	000	43540	64300	000 TEXAS TURNPIKE AUTHO	-1,450,000.00	-900,000.00	-900,000.00	62.1
2	000	49320	64300	000 G. O. BOND PROCEEDS	0.00	0.00	0.00	0.0
2	623	54270	64300	000 SIGNAL SYSTEMS/STREE	0.00	17,850.00	17,850.00	0.0
2	623	56040	64300	000 SPECIAL SERVICES	0.00	17,706.22	17,706.22	0.0
2	623	56180	64300	000 RENTAL	0.00	38,533.00	38,533.00	0.0
2	623	56510	64300	000 AUDIT AND LEGAL SERV	0.00	38,966.00	38,966.00	0.0
2	623	56570	64300	000 ENGINEERING/ARCHITEC	0.00	38,760.76	38,760.76	0.0
2	623	58110	64300	000 LAND PURCHASE	1,350,000.00	973,396.76	973,396.76	72.1
2	623	58910	64300	000 BUILDINGS	100,000.00	97,910.00	97,910.00	97.9
2	***	*****	64300	*** KELLER SPRINGS TOLL	0.00	323,122.74	323,122.74	0.0
2	621	56040	74100	000 SPECIAL SERVICES	0.00	22,765.31	22,765.31	0.0
2	621	56080	74100	000 ADVERTISING	0.00	99.00	99.00	0.0
2	621	56570	74100	000 ENGINEERING/ARCHITEC	0.00	0.00	0.00	0.0
2	***	*****	74100	*** 2001 AIRPORT PROJECT	0.00	22,864.31	22,864.31	0.0

GLRTB4 : GENERAL LEDGER CAPITAL PROJECT REPORT FISCAL YEAR 1997

FND : 12 AIRPORT FUND

Fn Dpt Acct Proj Sac Title	Revised Budget	Current Month Expenditures	Year-to-date Expenditures	% of Budget Expended
12 000 43110 74200 000 FAA GRANT	0.00	0.00	0.00	0.0
12 625 56040 74200 000 SPECIAL SERVICES	0.00	3,340.00	3,340.00	0.0
12 625 56510 74200 000 AUDIT AND LEGAL SERV	0.00	6,525.85	6,525.85	0.0
12 625 56570 74200 000 ENGINEERINGS/ARCHITEC	0.00	0.00	0.00	0.0
12 625 58110 74200 000 LAND PURCHASE	0.00	0.00	0.00	0.0
12 *** ***** 74200 *** WEST SIDE AIRPORT LA	0.00	9,865.85	9,865.85	0.0
12 623 56570 74300 000 ENGINEERING/ARCHITEC	0.00	0.00	0.00	0.0
12 *** ***** 74300 *** MIDWAY/DOOLEY INTERS	0.00	0.00	0.00	0.0
12 000 43110 84200 000 FAA GRANT	0.00	0.00	0.00	0.0
12 625 56570 84200 000 ENGINEERING/ARCHITEC	0.00	0.00	0.00	0.0
12 *** ***** 84200 *** AIRPORT PART 150 UPD	0.00	0.00	0.00	0.0
2 *** ***** ***** *** AIRPORT FUND	132,400.00	467,389.02	467,389.02	353.0

FAX

Date: 2-17-98

Page 1 of 5

To: Jim Pierce

Fax: 2837

From: Sandra Goforth-Town of Addison Finance Dept

PO Box 9010
Addison, Texas 75001-9010
5350 Belt Line Road
Addison, Texas 75240
(972) 450-7064 Fax (972) 450-7065

Addison!

- | | |
|---|--|
| <input type="checkbox"/> For your information/files | <input checked="" type="checkbox"/> Per your request |
| <input type="checkbox"/> Review & comment | <input type="checkbox"/> Sign and return |
| <input type="checkbox"/> Call me at your convenience to discuss | |

Comments:

FAX

Date: 2-16-98 Page 1 of 3

To: Jim Pierce

Fax: 2837

From: Sandra Goforth-Town of Addison Finance Dept.

PO Box 9010
Addison, Texas 75001-9010
5350 Belt Line Road
Addison, Texas 75240
(972) 450-7064 Fax (972) 450-7065

Addison!

- | | |
|---|--|
| <input type="checkbox"/> For your information/files | <input checked="" type="checkbox"/> Per your request |
| <input type="checkbox"/> Review & comment | <input type="checkbox"/> Sign and return |
| <input type="checkbox"/> Call me at your convenience to discuss | |

Comments:

Let me know if this is not ok —

FND : 12 AIRPORT FUND

Fn Dpt Acct Proj Sac Title	Revised Budget	Current Month Expenditures	Year-to-date Expenditures	% of Budget Expended
12 000 43110 44200 000 FAA GRANT	0.00	0.00	0.00	0.0
12 625 56080 44200 000 ADVERTISING	0.00	0.00	0.00	0.0
12 625 56510 44200 000 AUDIT AND LEGAL SERV	0.00	0.00	0.00	0.0
12 625 56570 44200 000 ENGINEERING/ARCHITEC	0.00	0.00	0.00	0.0
12 625 58210 44200 000 STREETS AND ALLEYS	0.00	0.00	0.00	0.0
12 *** ***** 44200 *** 1994 AIRPORT IMPROVE	0.00	0.00	0.00	0.0
12 000 43110 54200 000 FAA GRANT	-1,980,000.00	0.00	0.00	0.0
12 625 56080 54200 000 ADVERTISING	0.00	509.60	509.60	0.0
12 625 56510 54200 000 AUDIT AND LEGAL SERV	0.00	0.00	0.00	0.0
12 625 56570 54200 000 ENGINEERING/ARCHITEC	0.00	6,496.00	6,496.00	0.0
12 625 58110 54200 000 LAND PURCHASE	0.00	0.00	0.00	0.0
12 625 58210 54200 000 STREETS AND ALLEYS	2,045,000.00	0.00	0.00	0.0
12 *** ***** 54200 *** WEST TAXIWAY RECON 1	65,000.00	7,005.60	7,005.60	10.8
12 000 43110 54201 000 FAA GRANT	0.00	0.00	0.00	0.0
12 000 44211 54201 000 FAA GRANT	0.00	0.00	0.00	0.0
12 621 56570 54201 000 ENGINEERING/ARCHITEC	0.00	0.00	0.00	0.0
12 625 56510 54201 000 AUDIT AND LEGAL SERV	0.00	0.00	0.00	0.0
12 625 56570 54201 000 ENGINEERING/ARCHITEC	0.00	0.00	0.00	0.0
12 *** ***** 54201 *** AIRPORT MASTER PLAN	0.00	0.00	0.00	0.0
12 000 43540 64300 000 TEXAS TURNPIKE AUTHO	0.00	-17,850.00	-17,850.00	0.0
12 000 49320 64300 000 G. O. BOND PROCEEDS	-2,000,000.00	0.00	0.00	0.0
12 623 54270 64300 000 SIGNAL SYSTEMS/STREE	0.00	0.00	0.00	0.0
12 623 56040 64300 000 SPECIAL SERVICES	5,000.00	80.00	80.00	1.6
12 623 56180 64300 000 RENTAL	0.00	0.00	0.00	0.0
12 623 56510 64300 000 AUDIT AND LEGAL SERV	5,000.00	3,674.00	3,674.00	73.5
12 623 56570 64300 000 ENGINEERING/ARCHITEC	0.00	2,154.52	2,154.52	0.0
12 623 58110 64300 000 LAND PURCHASE	2,000,000.00	1,614.94	1,614.94	0.1
12 623 58910 64300 000 BUILDINGS	0.00	0.00	0.00	0.0
12 *** ***** 64300 *** KELLER SPRINGS TOLL	10,000.00	-10,326.54	-10,326.54	-103.3
12 621 56040 74100 000 SPECIAL SERVICES	25,000.00	46,611.08	46,611.08	186.4
12 621 56080 74100 000 ADVERTISING	0.00	0.00	0.00	0.0
12 621 56570 74100 000 ENGINEERING/ARCHITEC	50,000.00	17,750.81	17,750.81	35.5
12 *** ***** 74100 *** 2001 AIRPORT PROJECT	75,000.00	64,361.89	64,361.89	85.8

FND : 12 AIRPORT FUND

Fn Dpt Acct Proj Sac Title	Revised Budget	Current Month Expenditures	Year-to-date Expenditures	% of Budget Expended
12 000 43110 74200 000 FAA GRANT	0.00	-203,453.00	-203,453.00	0.0
12 625 56040 74200 000 SPECIAL SERVICES	0.00	0.00	0.00	0.0
12 625 56510 74200 000 AUDIT AND LEGAL SERV	0.00	3,999.50	3,999.50	0.0
12 625 56570 74200 000 ENGINEERING/ARCHITEC	0.00	0.00	0.00	0.0
12 625 58110 74200 000 LAND PURCHASE	0.00	437,038.50	437,038.50	0.0
12 *** ***** 74200 *** WEST SIDE AIRPORT LA	0.00	237,585.00	237,585.00	0.0
12 623 56570 74300 000 ENGINEERING/ARCHITEC	0.00	0.00	0.00	0.0
12 *** ***** 74300 *** MIDWAY/DOOLEY INTERS	0.00	0.00	0.00	0.0
12 000 43110 84200 000 FAA GRANT	-139,500.00	0.00	0.00	0.0
12 625 56570 84200 000 ENGINEERING/ARCHITEC	155,000.00	0.00	0.00	0.0
12 *** ***** 84200 *** AIRPORT PART 150 UPD	15,500.00	0.00	0.00	0.0
12 *** ***** ***** *** AIRPORT FUND	249,620.00	319,045.46	319,045.46	127.8

2-13-98

**SUMMARY OF PROJECT RELATED EXPENSES
ADDISON AIRPORT - WEST TAXIWAY AND CONNECTORS**

	Greiner	PSA Engineers (DBE)	Gorrondona & Assoc. (DBE)	Southwestern Labs	Maxim Technologies	Total
<u>PRELIMINARY PHASE</u>						
Design	47,380	8,640				56,020
Survey			16,540			16,540
Geotechnical				6,000		6,000
<u>FINAL PLANS</u>						
Design	47,402	14,288				61,690
<u>CONSTRUCTION SERVICES</u>						
Bidding/Award	7,412					7,412
Subtotal 1	102,194	22,928	16,540	6,000	0	147,662
<u>FINAL PLANS</u>						
Update/Revise	11,200					11,200
<u>CONSTRUCTION PHASE SERVICES</u>						
Construction Admin.	43,700					43,700
<u>RPR SERVICES/ACCEPTANCE TESTING</u>						
RPR Services	95,546					95,546
Acceptance Testing					22,000	22,000
Subtotal 2	150,446	0	0	0	22,000	172,446
<u>CONSTRUCTION PHASE SURVEYING</u>						
Control Monuments/Verify As Builts			6,000			6,000
Subtotal 3	0	0	6,000	0	0	6,000
TOTAL	252,640	22,928	22,540	6,000	27,000	326,108

**SUMMARY OF PROJECT RELATED EXPENSES
ADDISON AIRPORT - WEST TAXIWAY AND CONNECTORS**

	Greiner	PSA Engineers (DBE)	Gorrondona & Assoc. (DBE)	Southwestern Labs	Maxim Technologies	Total
<u>PRELIMINARY PHASE</u>						
Design	47,380	8,640				56,020
Survey			16,540			16,540
Geotechnical				6,000		6,000
<u>FINAL PLANS</u>						
Design	47,402	14,288				61,690
<u>CONSTRUCTION SERVICES</u>						
Bidding/Award	7,412					7,412
Subtotal 1	102,194	22,928	16,540	6,000	0	147,662
<u>FINAL PLANS</u>						
Update/Revise	11,200					11,200
<u>CONSTRUCTION PHASE SERVICES</u>						
Construction Admin.	43,700					43,700
<u>RPR SERVICES/ACCEPTANCE TESTING</u>						
RPR Services	95,546					95,546
Acceptance Testing					22,000	22,000
Subtotal 2	150,446	0	0	0	22,000	172,446
<u>CONSTRUCTION PHASE SURVEYING</u>						
Control Monuments/Verify As Built			6,000			6,000
Subtotal 3	0	0	6,000	0	0	6,000
TOTAL	252,640	22,928	22,540	6,000	27,000	326,108

facsimile
TRANSMITTAL



to: Jim Pierce / Assistant City Engineer
fax #:
re: Addison Airport West Taxiway and Connectors Project
date: February 12, 1998
pages: 2, including this cover sheet.

Attached for your review and use is a summary of the project related expenses for the West Taxiway project. Subtotal 1 represents what was spent on the project initially. Subtotal 2 represents where we are today, so to speak. And Subtotal 3 represents what we believe should be added to the budget for surveying during the construction phase. The surveying will include confirmation of the survey monuments at the start of construction, and verification of the as-built conditions for final quantity calculations at the end of the project.

Also, when we developed the budget for Acceptance Testing we got an estimate from Maxim Technologies. Their estimate for Alternates 1 and 3 is approximately \$19,000. The \$22,000 budgeted should be enough to cover any variances; however, I must mention that Maxim's estimate was preliminary and I will have them review it again before construction begins.

I hope this table is helpful to you in developing the information you need for TxDOT. If Clyde Johnson needs precise DBE figures, please let him know that we used a DBE reprographics firm to print up the plans and specs. We paid them \$2138.45 out of our \$11,200 fee for the updating and revising of the plans and specs.

From the desk of...

Leslie V. Sagar, P.E.
Project Manager
URS GREINER, INC.
4100 Amon Carter Blvd., Suite 108
Fort Worth, Texas 76155

(817) 545-0891
Fax: (817) 545-0534

GLRTB4 : GENERAL LEDGER CAPITAL PROJECT REPORT FISCAL YEAR 1995

FND : 12 AIRPORT FUND

Fn Dpt Acct Proj Sac Title	Revised Budget	Current Month Expenditures	Year-to-date Expenditures	% of Budget Expended
12 000 43110 44200 000 FAA GRANT	-1,400,000.00	-692,739.66	-692,739.66	49.5
12 625 56080 44200 000 ADVERTISING	0.00	0.00	0.00	0.0
12 625 56510 44200 000 AUDIT AND LEGAL SERV	1,500.00	2,000.00	2,000.00	133.3
12 625 56570 44200 000 ENGINEERING/ARCHITEC	50,000.00	70,884.05	70,884.05	141.8
12 625 58210 44200 000 STREETS AND ALLEYS	1,504,000.00	696,826.53	696,826.53	46.3
12 *** ***** 44200 *** 1994 AIRPORT IMPROVE	155,500.00	76,970.92	76,970.92	49.5
12 000 43110 54200 000 FAA GRANT	0.00	0.00	0.00	0.0
12 625 56080 54200 000 ADVERTISING	0.00	482.40	482.40	0.0
12 625 56510 54200 000 AUDIT AND LEGAL SERV	0.00	0.00	0.00	0.0
12 625 56570 54200 000 ENGINEERING/ARCHITEC	0.00	144,751.20	144,751.20	0.0
12 625 58110 54200 000 LAND PURCHASE	0.00	0.00	0.00	0.0
12 625 58210 54200 000 STREETS AND ALLEYS	0.00	0.00	0.00	0.0
12 *** ***** 54200 *** WEST TAXIWAY RECON 1	0.00	145,233.60	145,233.60	0.0
12 000 43110 54201 000 FAA GRANT	0.00	0.00	0.00	0.0
12 000 44211 54201 000 FAA GRANT	0.00	0.00	0.00	0.0
12 621 56570 54201 000 ENGINEERING/ARCHITEC	0.00	0.00	0.00	0.0
12 625 56510 54201 000 AUDIT AND LEGAL SERV	0.00	0.00	0.00	0.0
12 625 56570 54201 000 ENGINEERING/ARCHITEC	0.00	2,810.00	2,810.00	0.0
12 *** ***** 54201 *** AIRPORT MASTER PLAN	0.00	2,810.00	2,810.00	0.0
2 000 43540 64300 000 TEXAS TURNPIKE AUTHO	0.00	0.00	0.00	0.0
2 000 49320 64300 000 G. O. BOND PROCEEDS	0.00	0.00	0.00	0.0
2 623 54270 64300 000 SIGNAL SYSTEMS/STREE	0.00	0.00	0.00	0.0
2 623 56040 64300 000 SPECIAL SERVICES	0.00	0.00	0.00	0.0
2 623 56180 64300 000 RENTAL	0.00	0.00	0.00	0.0
2 623 56510 64300 000 AUDIT AND LEGAL SERV	0.00	0.00	0.00	0.0
2 623 56570 64300 000 ENGINEERING/ARCHITEC	0.00	0.00	0.00	0.0
2 623 58110 64300 000 LAND PURCHASE	0.00	0.00	0.00	0.0
2 623 58910 64300 000 BUILDINGS	0.00	0.00	0.00	0.0
2 *** ***** 64300 *** KELLER SPRINGS TOLL	0.00	0.00	0.00	0.0
2 621 56040 74100 000 SPECIAL SERVICES	0.00	0.00	0.00	0.0
2 621 56080 74100 000 ADVERTISING	0.00	0.00	0.00	0.0
2 621 56570 74100 000 ENGINEERING/ARCHITEC	0.00	0.00	0.00	0.0
2 *** ***** 74100 *** 2001 AIRPORT PROJECT	0.00	0.00	0.00	0.0

GLRTB4 : GENERAL LEDGER CAPITAL PROJECT REPORT FISCALYEAR 1996

FND : 12 AIRPORT FUND

Fn	Dpt	Acct	Proj	Sec Title	Revised Budget	Current Month Expenditures	Year-to-date Expenditures	% of Budget Expended
12	000	43110	44200	000 FAA GRANT	0.00	0.00	0.00	0.0
12	625	56080	44200	000 ADVERTISING	0.00	0.00	0.00	0.0
12	625	56510	44200	000 AUDIT AND LEGAL SERV	1,000.00	0.00	0.00	0.0
12	625	56570	44200	000 ENGINEERING/ARCHITEC	0.00	0.00	0.00	0.0
12	625	58210	44200	000 STREETS AND ALLEYS	0.00	0.00	0.00	0.0
12	***	*****	44200	*** 1994 AIRPORT IMPROVE	1,000.00	0.00	0.00	0.0
12	000	43110	54200	000 FAA GRANT	-1,862,100.00	0.00	0.00	0.0
12	625	56080	54200	000 ADVERTISING	0.00	0.00	0.00	0.0
12	625	56510	54200	000 AUDIT AND LEGAL SERV	1,000.00	0.00	0.00	0.0
12	625	56570	54200	000 ENGINEERING/ARCHITEC	25,000.00	2,100.56	2,100.56	8.4
12	625	58110	54200	000 LAND PURCHASE	0.00	0.00	0.00	0.0
12	625	58210	54200	000 STREETS AND ALLEYS	2,045,000.00	0.00	0.00	0.0
12	***	*****	54200	*** WEST TAXIWAY RECON 1	208,900.00	2,100.56	2,100.56	1.0
12	000	43110	54201	000 FAA GRANT	-135,000.00	-75,323.00	-75,323.00	55.8
12	000	44211	54201	000 FAA GRANT	0.00	0.00	0.00	0.0
12	621	56570	54201	000 ENGINEERING/ARCHITEC	0.00	0.00	0.00	0.0
12	625	56510	54201	000 AUDIT AND LEGAL SERV	0.00	1,000.00	1,000.00	0.0
12	625	56570	54201	000 ENGINEERING/ARCHITEC	147,000.00	83,994.16	83,994.16	57.1
12	***	*****	54201	*** AIRPORT MASTER PLAN	12,000.00	9,671.16	9,671.16	80.6
2	000	43540	64300	000 TEXAS TURNPIKE AUTHO	0.00	0.00	0.00	0.0
2	000	49320	64300	000 G. O. BOND PROCEEDS	0.00	0.00	0.00	0.0
2	623	54270	64300	000 SIGNAL SYSTEMS/STREE	0.00	0.00	0.00	0.0
2	623	56040	64300	000 SPECIAL SERVICES	0.00	10,700.00	10,700.00	0.0
2	623	56180	64300	000 RENTAL	0.00	0.00	0.00	0.0
2	623	56510	64300	000 AUDIT AND LEGAL SERV	0.00	7,170.00	7,170.00	0.0
2	623	56570	64300	000 ENGINEERING/ARCHITEC	0.00	4,704.32	4,704.32	0.0
2	623	58110	64300	000 LAND PURCHASE	0.00	4,637.50	4,637.50	0.0
2	623	58910	64300	000 BUILDINGS	0.00	0.00	0.00	0.0
2	***	*****	64300	*** KELLER SPRINGS TOLL	0.00	27,211.82	27,211.82	0.0
2	621	56040	74100	000 SPECIAL SERVICES	0.00	0.00	0.00	0.0
2	621	56080	74100	000 ADVERTISING	0.00	0.00	0.00	0.0
2	621	56570	74100	000 ENGINEERING/ARCHITEC	0.00	0.00	0.00	0.0
!	***	*****	74100	*** 2001 AIRPORT PROJECT	0.00	0.00	0.00	0.0

GLRTB4 : GENERAL LEDGER CAPITAL PROJECT REPORT FISCAL YEAR 1997

FND : 12 AIRPORT FUND

Fn	Dpt	Acct	Proj	Sac Title	Revised Budget	Current Month Expenditures	Year-to-date Expenditures	% of Budget Expended
12	000	43110	44200	000 FAA GRANT	0.00	0.00	0.00	0.0
12	625	56080	44200	000 ADVERTISING	0.00	0.00	0.00	0.0
12	625	56510	44200	000 AUDIT AND LEGAL SERV	0.00	0.00	0.00	0.0
12	625	56570	44200	000 ENGINEERING/ARCHITEC	0.00	0.00	0.00	0.0
12	625	58210	44200	000 STREETS AND ALLEYS	0.00	0.00	0.00	0.0
12	***	****	44200	*** 1994 AIRPORT IMPROVE	0.00	0.00	0.00	0.0
12	000	43110	54200	000 FAA GRANT	-450,000.00	0.00	0.00	0.0
12	625	56080	54200	000 ADVERTISING	0.00	0.00	0.00	0.0
12	625	56510	54200	000 AUDIT AND LEGAL SERV	0.00	0.00	0.00	0.0
12	625	56570	54200	000 ENGINEERING/ARCHITEC	0.00	810.22	810.22	0.0
12	625	58110	54200	000 LAND PURCHASE	500,000.00	0.00	0.00	0.0
12	625	58210	54200	000 STREETS AND ALLEYS	0.00	0.00	0.00	0.0
12	***	****	54200	*** WEST TAXIWAY RECON 1	50,000.00	810.22	810.22	1.6
12	000	43110	54201	000 FAA GRANT	-35,000.00	-52,942.00	-52,942.00	151.3
12	000	44211	54201	000 FAA GRANT	0.00	0.00	0.00	0.0
12	621	56570	54201	000 ENGINEERING/ARCHITEC	0.00	0.00	0.00	0.0
12	625	56510	54201	000 AUDIT AND LEGAL SERV	0.00	4,600.00	4,600.00	0.0
12	625	56570	54201	000 ENGINEERING/ARCHITEC	40,000.00	60,329.00	60,329.00	150.8
2	***	****	54201	*** AIRPORT MASTER PLAN	5,000.00	11,987.00	11,987.00	239.7
2	000	43540	64300	000 TEXAS TURNPIKE AUTHO	-1,450,000.00	-900,000.00	-900,000.00	62.1
2	000	49320	64300	000 G. O. BOND PROCEEDS	0.00	0.00	0.00	0.0
2	623	54270	64300	000 SIGNAL SYSTEMS/STREE	0.00	17,850.00	17,850.00	0.0
2	623	56040	64300	000 SPECIAL SERVICES	0.00	17,706.22	17,706.22	0.0
2	623	56180	64300	000 RENTAL	0.00	38,533.00	38,533.00	0.0
2	623	56510	64300	000 AUDIT AND LEGAL SERV	0.00	38,966.00	38,966.00	0.0
2	623	56570	64300	000 ENGINEERING/ARCHITEC	0.00	38,760.76	38,760.76	0.0
2	623	58110	64300	000 LAND PURCHASE	1,350,000.00	973,396.76	973,396.76	72.1
2	623	58910	64300	000 BUILDINGS	100,000.00	97,910.00	97,910.00	97.9
2	***	****	64300	*** KELLER SPRINGS TOLL	0.00	323,122.74	323,122.74	0.0
2	621	56040	74100	000 SPECIAL SERVICES	0.00	22,765.31	22,765.31	0.0
2	621	56080	74100	000 ADVERTISING	0.00	99.00	99.00	0.0
2	621	56570	74100	000 ENGINEERING/ARCHITEC	0.00	0.00	0.00	0.0
2	***	****	74100	*** 2001 AIRPORT PROJECT	0.00	22,864.31	22,864.31	0.0

GLRTB4 : GENERAL LEDGER CAPITAL PROJECT REPORT FISCAL YEAR 1997

FND : 12 AIRPORT FUND

Fn Dpt Acct Proj Sac Title	Revised Budget	Current Month Expenditures	Year-to-date Expenditures	% of Budget Expended
12 000 43110 74200 000 FAA GRANT	0.00	0.00	0.00	0.0
12 625 56040 74200 000 SPECIAL SERVICES	0.00	3,340.00	3,340.00	0.0
12 625 56510 74200 000 AUDIT AND LEGAL SERV	0.00	6,525.85	6,525.85	0.0
12 625 56570 74200 000 ENGINEERING/ARCHITEC	0.00	0.00	0.00	0.0
12 625 58110 74200 000 LAND PURCHASE	0.00	0.00	0.00	0.0
12 *** ***** 74200 *** WEST SIDE AIRPORT LA	0.00	9,865.85	9,865.85	0.0
12 623 56570 74300 000 ENGINEERING/ARCHITEC	0.00	0.00	0.00	0.0
12 *** ***** 74300 *** MIDWAY/DOOLEY INTERS	0.00	0.00	0.00	0.0
12 000 43110 84200 000 FAA GRANT	0.00	0.00	0.00	0.0
12 625 56570 84200 000 ENGINEERING/ARCHITEC	0.00	0.00	0.00	0.0
.2 *** ***** 84200 *** AIRPORT PART 150 UPD	0.00	0.00	0.00	0.0
2 *** ***** ***** *** AIRPORT FUND	132,400.00	467,389.02	467,389.02	353.0



H.B. ZACHRY COMPANY
FAECIMILE COVER SHEET
JOB 4568: ADDISON TOLL TUNNEL

Physical Address:
16101 Dooley Rd
Dallas, TX 75244

Mailing Address:
P.O. Box 1004
Addison, TX 75001-1004

Fax: (972) 267-0435
Phone: (972) 267-0430

To: Jim Pierce

Company: Town of Addison

Fax Number: 450-2837

Phone Number:

From: Majed Limam

Pages Sent: 4 (Including cover sheet)

Comments: Jim

Attached is needed info on Taxway Contract.
Call me @ (972) 267-0430.

Majed

If you do not receive all of the pages,
please call (972) 267-0430

D. Wayne Eason
Vice President

J&H Marsh & McLennan, Inc.
112 East Pecan, Suite 1400
San Antonio, Texas 78205
(210) 299-3308 Fax (210) 299-1249
D.Wayne.Eason@marsh.com

February 13, 1998

**J&H MARSH &
MCLENNAN**

Mrs. Susan P. LaBrie
Risk Management
H. B. Zachry Co.
P. O. Box 240130
San Antonio, Tx 78224-0130

Re: Town of Addison, Texas
5350 Belt Line
Addison, Tx
Construct West Taxiway and Connectors with Drainage Improvements
(South Segment) at Addison Airport

- 1.) General Liability
Indemnity Insurance Company of North America
Policy No. HD0G19326184
Term: May 01, 1997 to May 01, 1998
- 2.) Business Automobile Policy
Indemnity Insurance Company of North America
Policy No. ISA0732182A
Term: May 01, 1997 to May 10, 1998
- 3.) Umbrella Liability
National Union Fire Insurance Company
Policy No. BE9326067
Term: May 01, 1997 to May 01, 1998
- 4.) Builder's Risk
Zurich Insurance Company
Policy No. IM272510
Term: May 01, 1997 to May 01, 1998

Dear Susan:

The insurance premium for the referenced is based on the following rates:

- 1.) General Liability - \$3.75 per \$1000. receipts.
- 2.) Business Automobile - \$865. per unit
- 3.) Umbrella - \$1.90 per \$1,000. receipts (not adjustable)

CAGGJENSAX

A Marsh & McLennan Company

J&H Marsh & McLennan, Inc.
112 East Plaza, Suite 1400
San Antonio, Texas 78205
(210) 299-3308 Fax: (210) 299-1249
D.Wayne.Eason@Marshmc.com

Susan LaBrie
H. B. Zachry Co.
Page 2

**J&H MARSH &
MCLENNAN**

4.) Builder's Risk -

\$0.11 per \$100 completed value

If we can be of further assistance, please call.

Cordially,

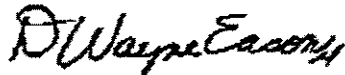

D. Wayne Eason

DWE/dwc

Encl

cc: Michelle Drew - M&M San Antonio

Copyright ©

A Marsh & McLennan Company

PROPOSAL AND BID FORMS

CONSTRUCT WEST TAXIWAY AND CONNECTORS WITH DRAINAGE IMPROVEMENTS
(SOUTH SEGMENT)

BIDDER acknowledges receipt of the following addendum:
(if non-issued, indicate N/A)

ADDENDA # 1 DCE DATE Jan 15, 1998

ADDENDA # _____ DATE _____

ADDENDA # _____ DATE _____

ADDENDA # _____ DATE _____

SUBCONTRACTORS:

BIDDER shall list below principal subcontractors proposed for use on this project:

NAME	ADDRESS	PHONE NO.
<i>Airport Markings of America</i>		<i>972-647-3773</i>
<i>Texas M H Construction Co, Inc</i>		<i>940-381-0837</i>
<i>Shampers</i>		<i>517-540-1162</i>
<i>Quality Green Scaping</i>		<i>517-572-9299</i>
<i>Texas-Mac Corp</i>		<i>972-481-5600</i>
<i>Austin Bridge & Road</i>		<i>972-241-0699</i>

Addison Airport
Construct West Taxiway and Connectors 1.37

facsimile
TRANSMITTAL

to: Jim Pierce / Assistant City Engineer
fax #:
re: Addison Airport West Taxiway and Connectors Project
date: February 12, 1998
pages: 2, including this cover sheet.

Attached for your review and use is a summary of the project related expenses for the West Taxiway project. Subtotal 1 represents what was spent on the project initially. Subtotal 2 represents where we are today, so to speak. And Subtotal 3 represents what we believe should be added to the budget for surveying during the construction phase. The surveying will include confirmation of the survey monuments at the start of construction, and verification of the as-built conditions for final quantity calculations at the end of the project.

Also, when we developed the budget for Acceptance Testing we got an estimate from Maxim Technologies. Their estimate for Alternates 1 and 3 is approximately \$19,000. The \$22,000 budgeted should be enough to cover any variances; however, I must mention that Maxim's estimate was preliminary and I will have them review it again before construction begins.

I hope this table is helpful to you in developing the information you need for TxDOT. If Clyde Johnson needs precise DBE figures, please let him know that we used a DBE reprographics firm to print up the plans and specs. We paid them \$2138.45 out of our \$11,200 fee for the updating and revising of the plans and specs.



From the desk of...

Leslie Y. Sagar, P.E.
Project Manager
URS GREINER, INC.
4100 Amon Carter Blvd., Suite 108
Fort Worth, Texas 76155

(817) 545-0531
Fax: (817) 545-0534

**SUMMARY OF PROJECT PLANNING EXPENSES
ADDISON AIRPORT - WEST TAXIWAY AND CONNECTORS**

	Greiner	PSA Engineers (DBE)	Gorrondona & Assoc. (DBE)	Southwestern Labs	Maxim Technologies	Total
PRELIMINARY PHASE						
Design	47,380	8,640				56,020
Survey			16,540			16,540
Geotechnical				6,000		6,000
FINAL PLANS						
Design	47,402	14,288				61,690
CONSTRUCTION SERVICES						
Bidding/Award	7,412					7,412
Subtotal 1	102,194	22,928	16,540	6,000	0	147,662
FINAL PLANS						
Update/Revise	11,200					11,200
CONSTRUCTION PHASE SERVICES						
Construction Admin.	43,700					43,700
RPR SERVICES/ACCEPTANCE TESTING						
RPR Services	95,546					95,546
Acceptance Testing					22,000	22,000
Subtotal 2	150,446	0	0	0	22,000	172,446
CONSTRUCTION PHASE SURVEYING						
Control Monuments/Verify As Built			6,000			6,000
Subtotal 3	0	0	6,000	0	0	6,000
TOTAL	252,640	22,928	22,540	6,000	22,000	326,108

Greiner

John

Job Westside Taxway

Project No. _____ Sheet _____ of _____

Description _____

Computed By _____ Date _____

Apparent Low Bidder

Checked By _____ Date 1/15/98

URS Greiner Estimate HB ZACHRY DUINNICK JRJ PAVINS

ALT	URS Greiner Estimate	HB ZACHRY	DUINNICK	JRJ PAVINS
1	2,354,800	1,962,590.72	2,175,145.00	2,330,826.00
2	2,147,615	1,877,196.32	1,995,766.70	No BID
3	71,310	88,037.35	58,450.00	71,190.00
4	2,625	3,376.10	1,150.00	1,750.00
→ 1+3	2,426,110	2,050,628.07	2,233,595.00	2,402,016.00
1+4	2,357,425	2,050,627.77 1,965,966.82	2,176,895.00	2,332,576.00
2+3	2,218,925	1,965,233.37	2,054,216.70	No BID
2+4	2,150,240	1,880,572.42	1,997,516.70	No BID

Δ 1+3 vs 2+3 = \$85,394.40

APPARENT LOW BIDDER : HB ZACHRY

Include Single Audit = \$2500

1. Engineering - Greiner
2. Resident Project Rep. Greiner
3. Construction - Concrete
4. Quality Control - Greiner

Jim -

Please prepare a letter summarizing our project cost post-estimated to Bruce Eddy - ~~State~~ TX DOT Aviation

Thanks John

Memo

2/25/98

To: Jim Pierce, Town of Addison
From: Jim Gardner, H. B. Zachry Co.
Subject: Revenue Curve

Jim:

Please find attached a copy of our forecasted revenue curve. Also attached is a cumulative one.
Please call me at 267-0430 if you have any questions.

March	April	May	June	July	August	Sept.	Oct.
\$0.00	\$339,030.00	\$554,880.00	\$833,440.00	\$1,122,940.00	\$1,730,440.00	\$1,950,628.00	\$2,050,628.00

Revenue Curve Cumulative

Addison Airport Taxiway

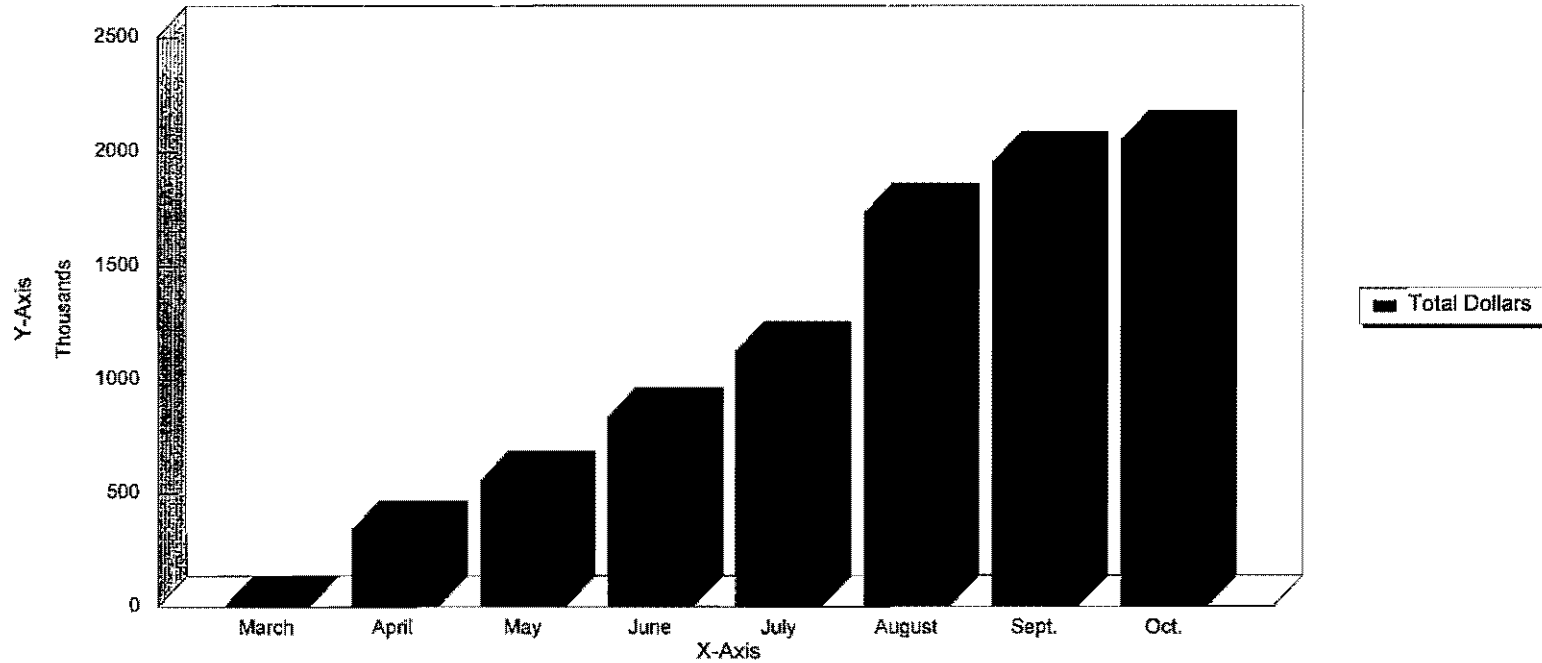

<i>April</i>	<i>May</i>	<i>Jun</i>	<i>July</i>	<i>Aug</i>	<i>Sept</i>	<i>Oct</i>	<i>Nov</i>
March	April	May	June	July	August	Sept.	Oct.
\$0.00	\$339,030.00	\$215,850.00	\$278,560.00	\$289,500.00	\$607,500.00	\$220,188.00	\$100,000.00

