

**CARROLLTON**

**STORMWATER  
AND  
FLOOD PROTECTION  
ORDINANCE**

**FEBRUARY 1994**

**NDM**

**NATHAN D. MAIER  
CONSULTING ENGINEERS, INC.**

---

**Dallas, Texas  
(214) 739-4741**

REC'D APR 18 1997



April 17, 1997

Mr. John Baumgartner, City Engineer  
Town of Addison  
P.O. Box 144  
Addison, TX 75001

Re: Addison Drainage Contribution

Dear Mr. Baumgartner:

The City of Carrollton has experienced considerable erosion and flooding problems within our city in the past. Due to these problems, the City of Carrollton has requested that neighboring cities and towns require developments, within drainage basins that discharge to and pass through the City of Carrollton, comply with the City of Carrollton Stormwater and Flood Protection Ordinance. We are enclosing a copy of this ordinance for your files.

Presently, both the City of Dallas and the City of Plano require that any development, whose drainage flows through the City of Carrollton, submit drainage plans to the City of Carrollton and obtain a letter stating that the development appears to conform to this ordinance. We are requesting your assistance in this area by asking that the City of Addison join with the cities of Dallas and Plano in requiring the same type of review and approval of drainage plans on sites contributing to the drainage flow through Carrollton.

Please respond in writing as to your consent to this request. If you should have any questions concerning the ordinance, or our request, feel free to contact us.

Sincerely,

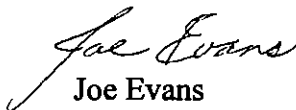

Joe Evans  
Division Manager/Design

cc: File  
Tim Tumulty, City Engineer

ENGINEERING

ORDINANCE NO. 2218

AN ORDINANCE OF THE CITY OF CARROLLTON, TEXAS AMENDING THE REVISED STORMWATER AND FLOOD PROTECTION ORDINANCE REGULATING DEVELOPMENT WITHIN THE CITY TO PROVIDE FOR ELEVATION CERTIFICATES, DETENTION AND RETENTION FACILITIES AND NON-RESIDENTIAL CONSTRUCTION; PROVIDING FOR A PENALTY FOR NON-COMPLIANCE; SEVERABILITY AND PROVIDING AN EFFECTIVE DATE

WHEREAS, the original Stormwater and Flood Protection Ordinance No. 1375 for the City of Carrollton was adopted by the City Council on May 12, 1987; and revised on February 15, 1994 (Ordinance 1964); and

WHEREAS, certain revisions of the Stormwater and Flood Protection Ordinance are necessary to promote orderly development of the city.

NOW, THEREFORE, BE IT ORDAINED BY THE COUNCIL OF THE CITY OF CARROLLTON, TEXAS:

Section 1.

That the "Stormwater and Flood Protection Ordinance", Article 4, Section C (Permits), Subsection 4 (Elevation Certificate) is hereby amended and shall read in its entirety as follows:

Developers, owners or builders shall complete an elevation certificate prior to issuance of a Certificate of Occupancy by the City whenever a development and/or building is constructed in a designated floodplain area.

Section 2.

That the "Stormwater and Flood Protection Ordinance", Article 7, Section D (Detention and Retention Facilities), Subsection 2 is hereby amended and shall read in its entirety as follows:

Detention areas in parking lots shall not be:

- In required parking spaces except as provided in Section D(7).
- Behind speed bumps unless the speed bumps are made with reinforced concrete.
- Deeper than six inches unless warning signs are posted.

Section 3.

That the "Stormwater and Flood Protection Ordinance," Article 7, Section D (Detention and Retention Facilities) is hereby amended to add subsection 7 which shall read in its entirety as follows:

7. Detention facilities will be allowed in the parking areas of commercial and/or industrial uses.

Section 4.

That the "Stormwater and Flood Protection Ordinance", Article 8, Section B (General Floodplain Regulations), Subsection 3 (Non-residential Construction) is hereby amended and shall read in its entirety as follows:

New construction in reclaimed floodplain areas and "substantial improvement" of any existing commercial, industrial, or other non-residential structure in floodplain areas shall either have the lowest floor, including basements of any new or "substantial improvement" construction, elevated to at least two feet above the design flood elevation; or, together with attendant utility and sanitary facilities, shall:

- Be floodproofed so that below two feet above the design flood elevation, the structure is watertight, with walls, substantially impermeable to the passage of water;
- Have structural components capable of resisting hydrostatic and hydrodynamic loads and effects of buoyancy; and
- Be certified by a registered professional engineer or architect that the standards of this subsection are satisfied. Such certifications shall be provided to the official set forth in Article 4, Section A.1.

Incremental improvements, either at one time or over a period of time, the cumulative cost of which equals or exceeds 50 percent of the market value at the time of the first improvement, shall be considered as a "substantial improvement." Improvements to an existing commercial, industrial or other non-residential structure that increase the outside dimensions, but do not result in a "substantial improvement," must meet the requirements of Article 8.C.

Parking lot pavement for the truck loading docks may be constructed below the design flood elevation.

Table 10 presents a synopsis of the requirements for nonresidential structures in floodplain areas.

Section 5.

That save and except as amended by this ordinance, Ordinance No. 1964 adopting the Stormwater and Flood Protection Ordinance, shall remain in full force and effect.

Section 6.

That conviction of a violation of the Stormwater and Flood Protection Ordinance is punishable in accordance with Section 10.99 of the Carrollton City Code.

Section 7.

That the provisions of this ordinance are severable in accordance with Section 10.07 of the Carrollton City Code.

Section 8.

That this ordinance shall be effective from and after the date of passage.

PASSED AND APPROVED THIS 15TH DAY OF OCTOBER 1996.

CITY OF CARROLLTON

  
Milburn R. Gravley, Mayor

ATTEST:

  
Pamela Schmidt  
City Secretary

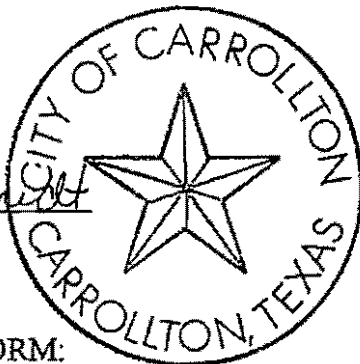

APPROVED AS TO FORM:

  
Karen Brophy  
City Attorney

APPROVED AS TO CONTENT:

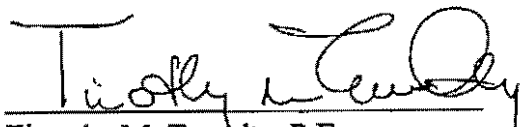
  
Timothy M. Tumulty, P.E.  
City Engineer

**STORMWATER  
AND  
FLOOD PROTECTION  
ORDINANCE**

**FEBRUARY 1994**

**ORDINANCE NO. 1964**

CODIFIED AS CHAPTER 174 OF THE CARROLLTON CITY CODE OF ORDINANCES

INDEX

ARTICLE 1 - TITLE, FINDINGS OF FACT, STATEMENT OF PURPOSE, SCOPE OF AUTHORITY, AND PENALTY FOR NON-COMPLIANCE

Section A. Title . . . . . 1  
Section B. Findings of Fact . . . . . 1  
Section C. Statement of Purpose . . . . . 1  
Section D. Scope of Authority . . . . . 2  
Section E. Organization of This Ordinance . . . . . 2  
Section F. Related Ordinances . . . . . 3

ARTICLE 2 - DEFINITIONS . . . . . 4

ARTICLE 3 - GENERAL PROVISIONS

Section A. Lands to Which This Ordinance Applies . . . . . 15  
Section B. Basis for Establishing the Areas of Special Flood Hazard. . . . . 15  
Section C. Penalty Clause . . . . . 15  
Section D. Repealing Clause . . . . . 15  
Section E. Abrogation and Greater Restrictions . . . . . 15  
Section F. Interpretation . . . . . 16  
Section G. Warning and Disclaimer of Liability . . . . . 16  
Section H. Severability . . . . . 16

ARTICLE 4 - ADMINISTRATION

Section A. Duties of City Officials . . . . . 17  
Section B. Responsibilities of Owners. . . . . 17  
Section C. Permits . . . . . 18  
Section D. Plan Requirements. . . . . 20  
Section E. Maintenance Bonds . . . . . 24  
Section F. Appeals and Variance Procedure. . . . . 25

ARTICLE 5 - RUNOFF CALCULATIONS

Section A. Procedure for Drainage Areas Less Than 160 Acres . . . . . 27  
Section B. Procedure for Drainage Areas Greater Than 160 Acres . . . . . 29

ARTICLE 6 - DESIGN OF LOCAL DRAINAGE SYSTEMS

Section A. Design Storm Frequencies . . . . . 30  
Section B. Street and Alley Capacities. . . . . 30  
Section C. Placement of Inlets. . . . . 31  
Section D. Inlet Capacities and Sizes . . . . . 31

Section E.	Pipe Design Standards . . . . .	31
Section F.	Culvert Design Standards . . . . .	36

ARTICLE 7 - SPECIAL DRAINAGE FACILITIES

Section A.	Channels . . . . .	37
Section B.	Lakes and Dams . . . . .	39
Section C.	Levees. . . . .	42
Section D.	Detention and Retention Facilities . . . . .	43
Section E.	Flumes. . . . .	44
Section F.	Connections from Buildings to Storm Sewers . . . . .	44

ARTICLE 8 - FLOODPLAIN GUIDELINES

Section A.	Lands to Which This Article Applies. . . . .	45
Section B.	General Floodplain Regulations . . . . .	45
Section C.	Floodplain Alterations . . . . .	49
Section D.	Verification of Floodplain Alterations . . . . .	50

ARTICLE 9 - CORRIDOR DEVELOPMENT CERTIFICATE PROCESS

Section A.	Trinity River Corridor Interlocal Agreement . . . . .	51
Section B.	Trinity River Corridor Area . . . . .	51
Section C.	Establishment of Development Permit . . . . .	51
Section D.	Duties and Responsibilities of the Floodplain Administrator . . . . .	52
Section E.	Common Permit Criteria. . . . .	52
Section F.	Exemptions from Corridor Development Certificate (CDC). . . . .	52
Section G.	Approval Process . . . . .	53
Section H.	Appeals Process . . . . .	53
Section I.	Technical Updates . . . . .	53
Section J.	CDC Manual . . . . .	53

ARTICLE 10 - STORM WATER DISCHARGES FROM CONSTRUCTION ACTIVITIES

Section A.	General Requirements . . . . .	55
Section B.	Five-Acre Disturbances . . . . .	57



## TABLES

TABLE 1 - VALUES OF "C" FOR USE IN RATIONAL METHOD FORMULA $Q = CIA$ . . . . .	.60
TABLE 2 - AVERAGE VELOCITY FOR USE IN DETERMINING TIME OF CONCENTRATION . . . . .	.61
TABLE 3 - MINIMUM SLOPES FOR CONCRETE PIPES . . . . .	.61
TABLE 4 - MAXIMUM VELOCITIES IN CONDUITS FLOWING FULL AND CHANNELS . . . . .	.62
TABLE 5 - ROUGHNESS COEFFICIENTS FOR CLOSED CONDUITS . . . . .	.62
TABLE 6 - ENTRANCE LOSS COEFFICIENTS . . . . .	.63
TABLE 7 - VELOCITY HEAD LOSS COEFFICIENTS FOR CLOSED CONDUITS . . . . .	.64
TABLE 8 - ROUGHNESS COEFFICIENTS FOR OPEN CHANNEL FLOW AREAS . . . . .	.65
TABLE 9 - SUITABLE VEGETATION FOR CHANNELS	
TEMPORARY VEGETATION . . . . .	.67
PERMANENT VEGETATION - LOW AREAS . . . . .	.68
PERMANENT VEGETATION - SIDE SLOPES . . . . .	.69
PERMANENT VEGETATION - BERMS, SPOIL BANKS, AND SIMILAR AREAS . . . . .	.70
TABLE 10 - SYNOPSIS OF REQUIREMENTS TO PROTECT STRUCTURES FROM FLOODING . . . . .	.72
TABLE 11 - PERMISSIBLE VELOCITIES FOR CHANNELS LINED WITH GRASS . . . . .	.76

## FIGURES

FIGURE 1	- CITY OF CARROLLTON RAINFALL INTENSITY VALUES . . . . .	77
FIGURE 2	- CAPACITY OF TRIANGULAR GUTTERS . . . . .	78
FIGURE 3	- CAPACITY OF PARABOLIC GUTTERS (26', 31' & 36' STREET WIDTHS). . . . .	79
FIGURE 4	- CAPACITY OF PARABOLIC GUTTERS (40' AND 44' STREET WIDTHS) . . . . .	80
FIGURE 5	- CAPACITY OF ALLEY SECTIONS . . . . .	81
FIGURE 6	- STORM DRAIN INLETS. . . . .	82
FIGURE 7	- RECESSED AND STANDARD CURB OPENING INLET CAPACITY CURVES ON GRADE (30' F-F STREET WIDTH, 5" PARABOLIC CROWN 36' F-F STREET WIDTH, 6" PARABOLIC CROWN) . . . . .	84
FIGURE 8	- RECESSED AND STANDARD CURB OPENING INLET CAPACITY CURVES ON GRADE (ALL STREET WIDTHS, 1/2 INCH/FOOT CROSS SLOPE CROWN). . . . .	85
FIGURE 9	- RECESSED AND STANDARD CURB OPENING INLET CAPACITY CURVES ON GRADE (ALL STREET WIDTHS, 1/4 INCH/FOOT CROSS SLOPE CROWN). . . . .	86
FIGURE 10	- RECESSED AND STANDARD CURB OPENING INLET CAPACITY CURVES ON GRADE (ALL STREET WIDTHS, 3/8 INCH/FOOT CROSS SLOPE CROWN; 40' F-F STREET WIDTH, 6" PARABOLIC CROWN; 44' F-F STREET WIDTH, 6" PARABOLIC CROWN) . . . . .	87
FIGURE 11	- RECESSED AND STANDARD CURB OPENING INLET CAPACITY CURVES ON GRADE (ALL STREET WIDTHS, 6" INVERTED CROWN) . . . . .	88
FIGURE 12	- RECESSED AND STANDARD CURB OPENING INLET CAPACITY CURVES AT LOW POINT (ALL STREET WIDTHS, STRAIGHT AND PARABOLIC CROWN). . . . .	89
FIGURE 13	- TWO GRATE COMBINATION INLET CAPACITY CURVES ON GRADE . . . . .	90
FIGURE 14	- THREE GRATE COMBINATION INLET CAPACITY CURVES ON GRADE. . . . .	91

FIGURE 15	-	FOUR GRATE COMBINATION INLET CAPACITY CURVES ON GRADE . . . . .	92
FIGURE 16	-	COMBINATION INLET CAPACITY CURVES AT LOW POINT . . . . .	93
FIGURE 17	-	TWO GRATE INLET CAPACITY CURVES ON GRADE . . . . .	94
FIGURE 18	-	FOUR GRATE INLET CAPACITY CURVES ON GRADE. . . . .	95
FIGURE 19	-	SIX GRATE INLET CAPACITY CURVES ON GRADE . . . . .	96
FIGURE 20	-	GRATE INLET CAPACITY CURVES AT LOW POINT . . . . .	97
FIGURE 21	-	DROP INLET CAPACITY CURVES AT LOW POINT. . . . .	98
FIGURE 22	-	CAPACITY OF CIRCULAR PIPES FLOWING FULL . . . . .	99
FIGURE 23	-	OUTFALL OF A STORM SEWER INTO A CHANNEL . . . . .	100
FIGURE 24	-	APPROXIMATE ROUTING METHOD FOR WATERSHEDS < 160 ACRES. . . . .	101
FIGURE 25	-	NATURAL FLOODWAY EXAMPLE . . . . .	103

**ORDINANCE NO. 1964**

**ARTICLE 1**

**SECTION 1**

**TITLE, FINDINGS OF FACT, STATEMENT OF PURPOSE,  
AND SCOPE OF AUTHORITY**

**ORGANIZATION OF THIS ORDINANCE**

**SECTION A. Title**

This Ordinance shall be known as the "Stormwater and Flood Protection Ordinance" of the City of Carrollton, and shall consist of a one hundred-three (103) page document attached hereto and made a part of this Ordinance.

**SECTION B. Findings of Fact**

1. The drainage ways and flood hazard areas of the City of Carrollton, Texas, are subject to periodic inundation which may result in loss of life and property, health and safety hazards, disruption of commerce and governmental services, and extraordinary public expenditures for flood protection and relief, all of which adversely affect the public health, safety, and general welfare.
2. These flood losses are created by the cumulative effect of obstructions in floodplains that increase flood heights and velocities and by the occupancy of flood hazard areas by uses vulnerable to floods and hazardous to other lands because they are inadequately elevated, floodproofed, or otherwise protected from flood damage.

**SECTION C. Statement of Purpose**

This ordinance sets forth the minimum requirements necessary to provide and maintain a safe, efficient, and effective drainage system within the City of Carrollton and to establish the various public and private responsibilities for the provision thereof. Further, it is the purpose of this ordinance to:

- (1) Protect human life, health, and property;
- (2) Minimize expenditure of public money for drainage related projects;
- (3) Minimize damage due to drainage to public and private facilities and utilities such as water and gas mains, electric service, telephone and sewer lines, streets and bridges;
- (4) Help maintain a stable tax base and preserve land values;
- (5) Insure that potential buyers are notified that property is in an area of special flood hazard;
- (6) Insure that those who occupy the areas of special flood hazard assume responsibility for their actions.
- (7) Preserve the natural beauty and aesthetics of the community.

- (8) Control and manage all stormwater runoff and drainage from points and surfaces within subdivisions.
- (9) Establish a reasonable standard of design for development which prevents potential flood and stormwater damage.

#### **SECTION D. Scope of Authority**

Except as exempted by Article 9, Section F, any person, firm, corporation, or business proposing to develop land or improve property within the City of Carrollton is subject to the provisions of this ordinance. This ordinance also applies to individual building structures, subdivisions, excavations and fill operations, and similar activities. The Scope of Authority extends to additional improvements on projects, developments, subdivisions, etc. which were previously permitted and/or constructed under the authority of prior ordinances or guidelines.

#### **SECTION E. Organization of This Ordinance**

This ordinance revises the provisions of the former "Stormwater and Flood Protection Ordinance" (Ordinance No. 1375) which combined the provisions of the former "Official Drainage and Stormwater Control Ordinance" (Ordinance No. 1051) and the "Flood Hazard Prevention Ordinance" (Ordinance No. 905). Further, it expands and clarifies various aspects of these ordinances. The following list is a synopsis of the contents of each article.

- Article 1 - discusses the purposes, scope, and authority of this ordinance, and provides a penalty for noncompliance with this ordinance.
- Article 2 - lists and defines various terms used in this ordinance.
- Article 3 - states general provisions related to implementation and enforcement of this ordinance.
- Article 4 - overviews the administrative procedures to be followed for obtaining the necessary City drainage approvals related to building on or improving property.
- Article 5 - explains the methodologies to calculate runoff quantities.
- Article 6 - gives the design standards for building local drainage systems (i.e., enclosed storm sewers).
- Article 7 - states additional design standards for specialty drainage system items.
- Article 8 - presents the floodplain regulations, including the requirements to be met when reclaiming floodplain land.
- Article 9 - presents additional regulations for activities within the Regulatory Zone of the Elm Fork Trinity River and tributaries.
- Article 10 - provides requirements for controlling storm water runoff and associated erosion for construction activities.

**SECTION F. Related Ordinances**

In addition to this ordinance, the City of Carrollton has other ordinances, regulations, and specifications pertaining to drainage and storm sewer facilities. These other documents include the zoning and subdivision ordinances, the Standard Specifications for Public Works Construction by the North Central Texas Council of Governments as amended by the City of Carrollton, and the General Design Standards for the City of Carrollton, and shall remain in full force and effect. If there is any conflict between such prior ordinance and this ordinance, this ordinance shall prevail.

## ARTICLE 2

### DEFINITIONS

Unless specifically defined below, words or phrases used in this ordinance shall be interpreted to give them the meaning they have in common usage and to give this ordinance its most reasonable application:

1. Angle of Flare

Angle between direction of a wingwall and centerline of culvert or storm drainage outlet or inlet.

2. Appeal

A request for review or interpretation of any provisions of this ordinance or a request for a variance.

3. Area of Shallow Flooding

A designated AO or AH Zone on the Flood Insurance Rate Map (FIRM). The base flood depths range from one to three feet; a clearly defined channel does not exist; and the path of flooding is unpredictable and indeterminate.

4. Area of Special Flood Hazard

The land in the floodplain within a community subject to a one percent or greater chance of flooding in any given year.

5. Base Flood

The flood having a one percent chance of being equalled or exceeded in any given year, determined based upon FEMA guidelines and as shown in the current effective Flood Insurance Study.

6. Base Flood Elevation

The water surface elevation resulting from the base flood.

7. Best Management Practices (BMP)

Consists of schedules of practices, maintenance procedures, and other management practices to prevent or reduce the pollution of waters of the United States. This also includes treatment requirements, operating procedures, and practices to control construction site runoff, spillage or leaks, sludge or waste disposal, or drainage from raw material storage.

8. City

The City of Carrollton, Texas, or the City Council of Carrollton.

9. City Engineer

The person appointed to the position of City Engineer by the City Council of the City of Carrollton, or his/her duly authorized representative.

10. Commencement of Construction  
The disturbance of soils associated with clearing, grading, or excavating activities or other construction activities.
11. Conduit  
Any closed device for conveying flowing water.
12. Corridor Development Certificate  
A required permit process established for activities within the Regulatory Zone of the Trinity River and its tributaries.
13. Critical Feature  
An integral and readily identifiable part of a flood protection system, without which the flood protection provided by the entire system would be compromised.
14. Design Flood  
The flood having a one percent chance of being equalled or exceeded in any given year based upon fully developed watershed conditions.
15. Detention Basin  
A dry basin or depression constructed for the purpose of temporarily storing storm water runoff and discharging all of that water over time at a reduced rate than would have otherwise occurred.
16. Developer/Builder  
A person, partnership, or corporation engaged in the development of land and/or building of structures and not excluded by exemption sections of this ordinance.
17. Development  
Any man-made change to improved or unimproved real estate, including but not limited to buildings or other structures, mining, dredging, filling, grading, paving, excavation, drilling operations, grading, or clearing.
18. Director of Public Works  
The person appointed to the position of Director of Public Works by the City Council of the City of Carrollton, or his/her duly authorized representative.
19. Discharge  
Any addition or introduction of any pollutant, storm water, or any other substance whatsoever into the municipal separate storm sewer system (MS4) or into waters of the United States.
20. Discharger  
Any person who causes, allows, permits, or is otherwise responsible for, a discharge, including, without limitation, any operator of a construction site or industrial facility.



21. Elevated Building
- In the case of Zones A1-30, A, A99, AO, B, C, D, V1-V30, and any other designated FEMA Zone, an "elevated building" includes a building elevated by means of fill so that the finished floor of the building is at least two feet above the water surface elevation of the design flood.
22. Entrance Head
- The head required to cause flow into a conduit or other structure; it includes both entrance loss and velocity head.
23. Entrance Loss
- Head lost in eddies or friction at the inlet to a conduit, headwall, or structure.
24. Environmental Protection Agency (EPA)
- The United States Environmental Protection Agency, the regional office thereof, any federal department, agency, or commission that may succeed to the authority of the EPA, any duly authorized official of EPA or such successor agency.
25. Equal Conveyance
- Principle of reducing stream conveyance for a proposed alteration with a corresponding reduction in conveyance to the opposite bank of the stream. The right of equal conveyance applies to all owners and uses and may be relinquished only by written agreements.
26. Erosion
- The wearing away of the land surface by running water, wind, ice, or other geological agents, including such processes as gravitational creep. In this manual, erosion due to storm water runoff is the primary design issue.
27. Existing Construction
- For the purposes of determining rates, structures for which the "start of construction" commenced before the effective date of Ordinance 905. "Existing construction" may also be referred to as "existing structures."
28. Facility
- Any building, structure, installation, process, or activity from which there is or may be a discharge of pollutant.
29. Federal Emergency Management Agency (FEMA)
- Federal agency which administers National Flood Insurance Program.
30. Final Stabilization
- The status when all soil disturbing activities at a site have been completed, and a uniform perennial vegetative cover with a density of 70% of the cover for unpaved areas and areas not covered by permanent structures has been established, or equivalent permanent stabilization measures (such as the use of riprap, gabions, or geotextiles) have been employed.

31. Flood or Flooding

A general and temporary condition of partial or complete inundation of normally dry land areas from:

- (1) The overflow of inland waters and/or
- (2) The unusual and rapid accumulation or runoff of surface waters from any source.

32. Flood Insurance Rate Map (FIRM)

The official map on which the Federal Emergency Management Agency has delineated both the areas of special flood hazards and the risk premium zones applicable to the community.

33. Flood Insurance Study

The official report in which the Federal Emergency Management Agency has provided flood profiles, the water surface elevation of the base flood, as well as the Flood Boundary-Floodway Map.

34. Floodplain or Flood-prone Area

Any land area susceptible to being inundated by water from any source (see definition of flooding).

35. Flood Protection System

Those physical structural works for which funds have been authorized, appropriated, and expended and which have been constructed specifically to modify flooding in order to reduce the extent of the areas within a community subject to a "special flood hazard" and the extent of the depths of associated flooding. Such a system typically includes hurricane tidal barriers, dams, reservoirs, levees or dikes. These specialized flood modifying works are those constructed in conformance with sound engineering standards.

36. Flume

Any open conduit on a prepared grade, trestle, or bridge.

37. Freeboard

The distance between the design flood elevation and the top of an open channel, dam, levee, or detention basin to allow for wave action, floating debris, or any other condition or emergency without overflowing the structure.

38. Functionally Dependent Use

A use which cannot perform its intended purpose unless it is located or carried out in close proximity to water. The term includes only docking facilities.

39. Harmful Quantity

The amount of any substance that will cause pollution of water in the State.

40. Highest Adjacent Grade

The highest natural elevation of the ground surface prior to construction next to the proposed walls of a structure.

41. Hydraulic Gradient

A line representing the pressure head available at any given point within the drainage system.

42. Levee

A man-made structure, usually an earthen embankment, designed and constructed in accordance with sound engineering practices to contain, control, or divert the flow of water so as to provide protection from temporary flooding.

43. Levee System

A flood protection system which consists of a levee, or levees, and associated structures, such as closure and drainage devices, which are constructed and operated in accordance with sound engineering practices.

44. Local Jurisdiction

The local governing body in which the construction takes place (known also as the City).

45. Lowest Floor

The lowest floor of the lowest enclosed area (including basement). An unfinished or flood resistant enclosure, usable solely for parking of vehicles, building access, or storage in an area other than a basement area is not considered a building's lowest floor, provided that such enclosure is not built so as to render the structure in violation of the applicable non-elevation design requirements of FEMA under 44 CFR, 60.3.

46. Manning Equation

The uniform flow equation used to relate velocity, hydraulic radius, and energy gradient slope.

47. Manufactured Home

A structure transportable in one or more sections, which is built on a permanent chassis and is designed for use with or without a permanent foundation when connected to the required utilities. For floodplain management purposes, the term "manufactured home" also includes park trailers, travel trailers, and other similar vehicles placed on a site for greater than 180 consecutive days. The "manufactured home" does not include a "recreational vehicle".

48. Manufactured Home Park or Subdivision

A parcel or contiguous parcels of land divided into two or more manufactured home lots for rent or sale.

49. Maximum Extent Practicable (MEP)

The goal of pollutant reduction through the use of best management practices.

50. Mean Sea Level

For purposes of the National Flood Insurance Program, the National Geodetic Vertical Datum (NGVD) of 1929 or other datum, to which base flood elevations shown on a community's Flood Insurance Rate Map are referenced.

51. Municipal Separate Storm Sewer System (MS4)

The system of conveyances (including roads with drainage systems, municipal streets, catch basins, curbs, gutters, ditches, man-made channels or storm drains) owned and operated by the City and designed or used for collecting or conveying storm water, and which is not used for collecting or conveying sewage.

52. Municipal Solid Waste

Solid waste resulting from or incidental to municipal, community, commercial, institutional, or recreational activities, and includes garbage, rubbish, ashes, street cleanings, dead animals, abandoned automobiles, and other solid waste other than industrial waste.

53. NPDES General Permit for Storm Water Discharges Associated with Industrial Activity (or Industrial General Permit)

The Industrial General Permit issued by EPA on August 27, 1992 and published in Volume 57 of the Federal Register at page 41304 on September 9, 1992, and any subsequent modifications or amendments thereto.

54. NPDES General Permit for Storm Water Discharge for Construction Sites (or Construction General Permit)

The Construction General Permit issued by EPA on August 27, 1992, and published in Volume 57 of the Federal Register at page 41217 on September 9, 1992, and any subsequent modifications or amendments thereto.

55. NPDES Permit

A National Pollutant Discharge Elimination System permit issued by EPA (or by the State under authority delegated pursuant to 33 USC & 1342(b) that authorizes the discharge of pollutants to waters of the United States, whether the permit is applicable on an individual group, or general area-wide basis.

56. Natural Drainage

The dispersal of surface waters through ground absorption and by drainage channels formed by the existing surface topography which exists at the time of adoption of this ordinance or formed by any man-made change in the surface topography.

57. Natural Floodway

The effective area of a channel of a river or other water course and the adjacent land areas that must be reserved in order to discharge the "design flood" without cumulatively increasing the water surface elevation. This floodway differs from the FEMA "regulatory floodway."

58. New Construction

Structures for which the "start of construction" commenced on or after the effective date of Ordinance 905.

59. Non-Point Source

Any source of any discharge of a pollutant that is not a "point source".

60. Notice of Intent (NOI)

The Notice of Intent that is required by either the Industrial General Permit or the Construction General Permit. Documentation of construction activity which is submitted to the EPA and the local jurisdiction prior to construction. It serves as notification of construction activity as well as a commitment by the owner that he/she understands the requirements of the NPDES General Permit for Storm Water Discharges From Construction Activities and that measures will be taken to implement and maintain a SWPPP at the site.

61. Notice of Termination (NOT)

The Notice of Termination that is required by either the Industrial General Permit or the Construction General Permit. A completed form sent to the EPA and local jurisdiction (City of Carrollton) upon stabilization of the site that serves as notice that the site is no longer subject to the requirements of the NPDES General Permit for Storm Water Discharges From Construction Activities.

62. Open Channel

A channel in which water flows with a free surface.

63. Operator

The person or persons who, either individually or taken together, meet the following two criteria:

- (1) they have operational control over the facility specifications (including the ability to make modifications in specifications); and
- (2) they have the day-to-day operational control over those activities at the facility necessary to ensure compliance with pollution prevention requirements and any permit conditions.

64. Other Municipal Ordinances

Ordinances such as, but not limited to, zoning, subdivision, and erosion.

65. Owner

The person who owns a facility or part of a facility.

66. Person

Any individual, partnership, co-partnership, firm, company, corporation, association, joint stock company, trust, estate, governmental entity, or any other legal entity; or their legal representatives, agents, or assigns. This definition includes all federal, state, and local governmental entities.

67. Point Source

Any discernible, confined, and discrete conveyance, including but not limited to, any pipe, ditch, channel, tunnel, conduit, well, discrete fissure, container, rolling rock, concentrated animal feeding operation, landfill leachate collection system, vessel or other floating craft from which pollutants are or may be discharged. This term does not include return flows from irrigated agriculture or agricultural storm water runoff.

68. Pollutant

Dredged spoil, solid waste, incinerator residue, sewage, garbage, sewage sludge, munitions, chemical waste, biological materials, radioactive materials, rock, sand, dirt or cellar dirt generated as part of a construction project.

69. Pollution

The alteration, due to a construction project, of the physical, thermal, chemical, or biological quality of, or the contamination of, any water in the State that renders the water harmful, detrimental, or injurious to humans, animals life, vegetation, or property, or to the public health, safety, or welfare, or impairs the usefulness or the public enjoyment of the water for any lawful or reasonable purpose.

70. Probable Maximum Flood (PMF)

The flood magnitude that may be expected from the most critical combination of meteorologic and hydrologic conditions that are reasonably possible for a given watershed.

71. Probable Maximum Precipitation (PMP)

Theoretically the greatest depth of precipitation for a given duration that is physically possible over a given size storm area at a particular geographical location at a certain time of the year.

72. Qualified Personnel

Persons who possess the appropriate competence, skills, and ability (as demonstrated by sufficient education, training, experience, and/or, when applicable, any required certification or licensing) to perform a specific activity in a timely and complete manner consistent with the applicable regulatory requirements and generally-accepted industry standards for such activity.

73. Rational Formula

The means of relating runoff with the area being drained and the intensity of the storm rainfall.

74. Recreational Vehicle

Means a vehicle which is (i) built on a single chassis; (ii) 400 square feet or less when measured at the largest horizontal projections; (iii) designed to be self-propelled or permanently towable by a light duty truck; and (iv) designed primarily not for use as a permanent dwelling but as temporary living quarters for recreational, camping, travel, or seasonal use.

75. Registered Landscape Architect (RLA)

A person who has been duly licensed and registered to practice landscape architecture by the Texas Board of Architectural Examiners.

76. Registered Professional Engineer (RPE)

A person who has been duly licensed and registered by the State Board of Registration for Professional Engineers to engage in the practice of engineering in the State of Texas.

77. Regulatory Floodway

The channel of a river or other watercourse and the adjacent land areas that must be reserved in order to discharge the "base flood," as calculated by the Federal Emergency Management Agency, without cumulatively increasing the water surface elevation more than a designated height. This floodway is used by FEMA to determine compliance with its regulations.

78. Regulatory Zone

The area within the 100-year floodplain of the specified reach of the Trinity River as defined by the latest approved version of the digital Trinity River Corridor Map - CDC Regulatory and Review Zones maintained by NCTCOG.

79. Retention Basins

A pond or other water body which has been designed to have both a conservation pool for holding some water indefinitely and a flood storage pool for storing storm water runoff on a temporary basis for the purpose of reducing the peak discharge from the basin.

80. Sanitary Sewer (or Sewer)

The system of pipes, conduits, and other conveyance which carry industrial waste and domestic sewage from residential dwellings, commercial buildings, industrial and manufacturing facilities, and institutions, whether treated or untreated, to the sewage treatment plant serving the City (and to which storm water, surface water, and groundwater are not intentionally admitted).

81. Sediment

The soil particles deposited through the process of sedimentation as a product of erosion. These soil particles settle out of runoff at variable rates based on the size of the particle and soil type.

82. Site

The land or water area where any facility or activity is physically located or conducted, including adjacent land used in connection with the facility or activity.

83. Standard Project Flood

Flood that has a magnitude of approximately one half of the probable maximum flood, as determined on a case-by-case basis using Corps of Engineers' current criteria.

84. Start of Construction

For a structure, "start of construction" includes substantial improvement and means the date the development or building permit was issued, provided the actual start of construction, repair, reconstruction, placement, or other improvement was within 180 days of the permit date. The actual start means either the first placement of permanent construction of a structure on a site, such as the pouring of slab or footings, the installation of piles, the construction of columns, or any work beyond the stage of excavation; or the placement of a manufactured home on a foundation. Permanent construction of a structure does not include land preparation, such as clearing, grading, and filling, nor does it include the installation of streets and/or walkways; nor does it include excavation for basement, footings, piers, or foundations or the erection of temporary forms; nor does it include the installation on the property of accessory buildings, such as garages or sheds not occupied as dwelling units or not part of the main structure.

85. Storm Water

Storm water runoff, snow melt runoff, and surface runoff and drainage.

86. Storm Water Pollution Prevention Plan (SWPPP)

A plan required by either the Construction General Permit or the Industrial General Permit and which describes and ensures the implementation of practices that are to be used to reduce the pollutants in storm water discharges associated with construction or other industrial activity at the facility.

87. Structure

A walled and roofed building, a manufactured home, a gas or liquid storage tank, or a substation that is principally above ground.

88. Substantial Improvement

Any combination of repairs, reconstructions, or improvements of a structure, the cumulative cost of which equals or exceeds 50 percent of the initial market value of the structure either:

- (1) before the first improvement or repair is started, or
- (2) if the structure has been damaged and is being restored, before the damage occurred.

For the purpose of this definition, "substantial improvement" is considered to occur when the first alteration of any wall, ceiling, floor, or other structural part of the building commences, whether or not that alteration affects the external dimensions of the structure. Incremental improvements over a period of time, the cumulative cost of which equals or exceeds 50 percent of the market value at the time of the first improvement, shall be considered as a "substantial improvement."

The term does not, however, include either:

- (1) any project for improvement of a structure to comply with existing State or local health, sanitary, or safety code specifications which are solely necessary to assure safe living conditions or,
- (2) any alteration of a structure listed on the National Register of Historic Places or a State Inventory of Historic Places.



89. Surety

A corporation surety bond, cash, or certificate of deposit.

90. Time of Concentration

The estimated time in minutes or hours required for a drop of water to flow from the most remote point in the drainage area to the point at which the flow is to be determined.

91. Use

Any purpose for which a building or other structure or a tract of land may be designed, arranged, intended, maintained, or occupied; or any activity, occupation, business, or operation carried on, or intended to be carried on, in a building or other structure or on a tract of land.

92. Use Permit

The permit required before any use may be commenced.

93. Variance

A grant of relief to a person from the requirements of this ordinance when specific enforcement would result in unnecessary hardship. A variance, therefore, permits construction or development in a manner otherwise prohibited by this ordinance.

94. Violation

The failure of a structure or other development to be fully compliant with this ordinance. A structure or other development without the FEMA elevation certificate prior to a certificate of occupancy, other certifications, or other evidence as required by the City Manager, is presumed to be in violation until such time as that documentation is provided.

95. Watershed

The area drained by a stream or drainage system.

96. Waters of the United States

All waters which are currently used, were used in the past, or may be susceptible to use in interstate or foreign commerce, including all waters which are subject to the ebb and flow of the tide; all interstate waters, including interstate wetlands; all other waters the use, degradation, or destruction of which would affect or could affect interstate or foreign commerce; all impoundments of waters otherwise defined as waters of the United States under this definition; all tributaries of waters identified in this definition; all wetlands adjacent to waters identified in this definition; and any waters within the federal definition of "waters of the United States" at 40 CFR 122.2; but not including any waste treatment systems, treatment ponds, or lagoons designed to meet the requirements of the federal Clean Water Act.

97. Water Surface Elevation

The height, in relation to the NGVD or 1929 (or other datum, where specified), of floods of various magnitudes and frequencies in the floodplains of riverine areas.

## ARTICLE 3

### GENERAL PROVISIONS

#### **SECTION A. Lands to Which This Ordinance Applies**

This ordinance shall apply to all areas of land within the jurisdiction of the City of Carrollton, Texas. Certain provisions of this ordinance apply only to special flood hazard areas within the jurisdiction of the City of Carrollton, while other provisions exempt certain other tracts. These limited areas of application are explained in the applicable provisions (See Article 8, Section A). This ordinance also extends the Scope of Authority to additional improvements on projects, developments, subdivisions, etc. which were previously permitted and/or constructed under the authority of prior ordinances or guidelines.

#### **SECTION B. Basis for Establishing the Areas of Special Flood Hazard**

The areas of special flood hazard identified by the Federal Emergency Management Agency in a scientific and engineering report entitled "The Flood Insurance Study for the City of Carrollton," dated January 2, 1991, with accompanying Flood Insurance Rate Maps and Flood Hazard Boundary-Floodway Maps and any revision thereto are hereby adopted by reference and declared to be a part of this ordinance. The Flood Insurance Study is on file in the office of the City Engineer.

#### **SECTION C. Penalty Clause**

Any person, firm or corporation violating any of the provisions of this ordinance shall be deemed guilty of a misdemeanor and, upon conviction, shall be punished by a penalty or fine not to exceed the sum of One Thousand Dollars (\$1,000.00) for each offense, and each and every day such offense is continued shall constitute a new and separate offense. In addition, the violator shall pay all costs and expenses involved in the case. Nothing herein contained shall prevent the City of Carrollton from taking such other lawful action as is necessary to prevent or remedy any violation. Article 4, Section C.3 states an additional penalty against persons proceeding with construction without obtaining the necessary permits from the City of Carrollton.

#### **SECTION D. Repealing Clause**

The "Stormwater and Flood Protection Ordinance" (Ordinance No. 1375); "Official Drainage and Stormwater Control Ordinance" (Ordinance No. 1051); and the "Flood Hazard Prevention Ordinance" (Ordinance No. 905), heretofore adopted by the City Council of Carrollton, Texas, shall be and the same are hereby expressly repealed. All provisions of all ordinances conflicting with the provisions hereof are hereby repealed. All other ordinances and provisions of such ordinances not expressly in conflict with the provisions hereof shall remain in full force and effect.

#### **SECTION E. Abrogation and Greater Restrictions**

This ordinance is not intended to repeal, abrogate, or impair any existing easements, covenants, or deed restrictions. However, where this ordinance and other ordinance, easement, covenant, or deed restriction conflict or overlap, whichever imposes the more stringent restrictions shall prevail.

**SECTION F. Interpretation**

In the interpretation and application of this ordinance, all provisions shall be:

- (1) Considered as minimum requirements;
- (2) Liberally construed in favor of the governing body; and,
- (3) Deemed neither to limit nor repeal any other powers granted under State statutes.

**SECTION G. Warning and Disclaimer of Liability**

The degree of flood protection required by this ordinance is considered reasonable for regulatory purposes and is based on scientific and engineering considerations. Larger floods can and will occur on rare occasions. Flood heights may be increased by man-made or natural causes. This ordinance does not imply that land outside the area of special flood hazards or uses permitted within such areas will be free from flooding or flood damages. This ordinance shall not create liability on the part of the City of Carrollton, any officer or employee thereof or the Federal Emergency Management Agency for any flood damages that result from reliance on this ordinance or any administrative decision lawfully made thereunder.

**SECTION H. Severability**

If any section, paragraph, clause, phrase, or provision of this ordinance shall be adjudged invalid or held unconstitutional, the same shall not affect the validity of this ordinance as a whole or any part or provision thereof, other than the part so decided to be invalid or unconstitutional; nor shall such unconstitutionality or invalidity have any effect on any other ordinances or provisions of ordinances of the City of Carrollton.

## ARTICLE 4

### ADMINISTRATION

#### SECTION A. Duties of City Officials

##### 1. Duties of the City Manager

The City Manager is hereby appointed to administer and implement the floodplain management portions of this ordinance, including Articles 8 and 9 and other appropriate sections of 44 CFR (National Flood Insurance Program Regulations) pertaining to floodplain management. The duties of the City Manager or his designee shall include but not be limited to:

- Review and approval of all Development Permits to determine that the permit requirements of this ordinance have been met and that all necessary State and Federal permits have been obtained;
- Obtain and record the actual elevation in relation to mean sea level of the lowest habitable floor, including basement of all new or substantially improved structures, and whether or not the structure contains a basement;
- Maintain for public inspection all records pertaining to the provisions of this ordinance, including floodproofing certifications;
- Notify adjacent communities and the Texas Natural Resources Conservation Commission prior to any alteration or relocation of a watercourse, and submit evidence of such notification to the Federal Emergency Management Agency;
- Require that maintenance is provided within the altered or relocated portion of said watercourse so that the flood-carrying capacity is not diminished;
- Make interpretations, where needed, as to the exact location of the boundaries of the areas of special flood hazards (for example, where there appears to be a conflict between a mapped boundary and actual field conditions); and
- Obtain, review, and reasonably utilize any base flood elevation data available from a Federal, State or other source, in order to administer this ordinance when base flood elevation data has not been provided.

##### 2. Duties of the City Engineer

The City Engineer is hereby appointed to administer and implement the storm drainage system portion of this ordinance, and to assist the City Manager with the technical aspects of the floodplain management portions of this ordinance.

#### SECTION B. Responsibilities of Owners

The owner or developer of property to be developed shall be responsible for all storm drainage flowing through or abutting such property. This responsibility also includes drainage directed to that property by ultimate development as well as the drainage naturally flowing through the property by reason of topography. It is the intent of this ordinance that provision be made for storm drainage at such time as any property affected is proposed for development, use, or modification.

It is the intent of this ordinance that provision be made for storm drainage at such time as any property affected is proposed for development, use, or modification.

Where the improvement or construction of a storm drainage facility is required along a property line common to two or more owners, the owner hereafter proposing development of the property shall be responsible for the required improvements at the time of development, including the dedication of all necessary rights-of-way or easements, to accommodate the improvements.

Where a property owner proposes development or use of only a portion of the property, provision for storm drainage shall only be required in that portion of the property proposed for immediate development, except as construction or improvements of a drainage facility outside that designated portion of the property is deemed essential to the development of that designated portion.

Owners shall provide for stormwater runoff and design drainage related facilities in accordance with and/or in a compatible manner with any City of Carrollton master drainage study and plan in effect at the time when plans for drainage facilities are submitted to the City for approval.

In addition, owners may be required to provide at their expense a preliminary drainage study for the total area to be ultimately developed. This study shall be submitted to the City Engineer as a part of the submitted data for consideration of preliminary plat or site plan approval for the portion of the property proposed for immediate development.

#### **SECTION C. Permits**

The City of Carrollton has several permits related to storm drainage. Some of these permits are listed below and explained in detail in the following paragraphs. Permits required by other ordinances may also be needed.

- Development Permit
- Floodplain Alteration Permit, formerly called the Fill Permit
- Corridor Development Certificate (See Article 9)

##### **1. Development Permit**

All developers, owners, or builders shall obtain and submit for approval a Development Permit application for new construction, placement of fill, new manufactured home sites, alteration of a waterway, substantial improvements to existing structures or manufactured homes, or improvements to existing structures, or manufactured homes in the floodplain of the design flood that will result in increasing the overall outside dimensions of the structure or manufactured home. The application form can be obtained from the City Engineer's office. The City Engineer uses this form, along with duplicate copies of the accompanying engineering or architectural plans, to identify those construction or renovation projects that would occur in a flood hazard area. As a minimum, the engineering or architectural plans shall show, to scale:

- a. The nature, location, dimensions, and elevations in relation to mean sea level of the area in question.
- b. The elevation in relation to mean sea level and the location of existing or proposed structures, fill, storage of materials, and/or drainage facilities.
- c. The elevation in relation to mean sea level to which an existing non-residential structure shall be floodproofed, the location of the foregoing.

- d. Any off-site facilities or conditions that may either affect on-site conditions or be affected by on-site conditions.

If an existing non-residential structure is proposed for floodproofing, then a certificate sealed by a registered professional engineer in the State of Texas shall be submitted stating that all of the floodproofing criteria listed in Article 8, Section B will be met. Construction or renovation projects cannot begin until the City issues the Development Permit.

2. Floodplain Alteration Permit

Developers, owners, or builders shall obtain a Floodplain Alteration Permit prior to filling in a floodplain; channelizing, impounding, realigning, deepening, or otherwise modifying a natural drainage way; making improvements, substantial or otherwise, to existing structures or manufactured homes in a floodplain if the improvements result in the increase of the overall outside dimensions of the structures or manufactured homes; or otherwise reclaiming floodplain land. A Floodplain Alteration Permit application form can be obtained from the City Engineer's office. This form along with duplicate copies of the engineering plans, reports, etc., shall be used by the City Engineer in reviewing the permit application. Article 4, Section D.2 identifies the information that must be submitted to the City Engineer. No floodplain alterations shall begin until a permit is issued by the City Engineer.

3. Corridor Development Certificate

Developers, owners, or builders shall obtain a Corridor Development Certificate (CDC) prior to work in a Regulatory Zone of the floodplain; which includes but is not limited to filling, channelizing, impounding, realigning, deepening, or otherwise modifying a natural drainageway; making improvements, substantial or otherwise, to existing structures or manufactured homes in a floodplain if the improvements result in the increase of the overall outside dimensions of the structures or manufactured homes; or otherwise reclaiming floodplain land. A CDC application form can be obtained from the City Engineer's office. This form along with duplicate copies of the engineering plans, reports, etc., shall be used by the City Engineer in reviewing the CDC application. Article 9 identifies the information that must be submitted to the City Engineer. No floodplain alternations shall begin until a CDC permit is issued by the City Engineer.

4. Elevation Certificate

Developers, owners, or builders shall complete an elevation certificate prior to issuance of a Certificate of Occupancy by the City. Elevation Certificate forms can be obtained at the City Engineer's office.

5. Proceeding Without the Applicable Permits

Any developer, owner, or builder who fails to obtain the applicable Development, Floodplain Alteration and/or CDC permit before beginning the subject project is in violation of this ordinance. In addition to the penalties outlined in Article 3, Section C, no Building Permit, plat, site plan, or Certificate of Occupancy shall be issued for any construction, reconstruction, or development upon any land where such construction, reconstruction, or development is not in conformity with the requirements and intent of this ordinance. Any one who violates any of the terms and provisions of this ordinance shall be denied a Building Permit, etc., until the violation is corrected.

6. Deviations from Permit Terms

Permits may be revoked by the City Engineer if, upon periodic inspection, he determines that the work is not progressing in accordance with specifications of the approved plan and permit.

Field changes to storm sewer plans can be made only upon approval by the City Engineer. Record drawings shall be submitted to the City Engineer at the completion of the project.

**SECTION D. Plan Requirements**

Plan requirements for stormwater drainage systems and floodplain alterations are listed below. All engineering plans shall be sealed by a professional engineer who is registered in the State of Texas and experienced in civil engineering work. The total cost for such engineering plans and specifications shall be borne by the owner or the developer and shall be furnished to the City Engineer for review and approval.

1. Drainage Plans

As part of the platting process, drainage plans shall be prepared. These plans shall include drainage facilities for both off-site and on-site drainage so that the proper transition between the two can be maintained. Criteria for on-site development shall also apply to off-site improvements.

The construction of all improvements shall be in accordance with the current Standard Specifications for Public Works Construction by the North Central Texas Council of Governments as amended by the City of Carrollton, and Design Standards of the City of Carrollton.

The drainage plans shall include:

a. Drainage Area Map

1. Use 1"=200' scale for the development and up to 1"=2000' for creeks and off-site areas, provide that the scale is adequate for review, and show match lines between any two or more maps.
2. Show existing and proposed storm sewers and inlets.
3. Indicate sub-areas for each alley, street, off-site, etc.
4. Indicate contours on map for on- and off-site.
5. Indicate zoning on drainage area.
6. Show points of concentration.
7. Indicate runoff at all inlets, dead-end streets and alleys, or to adjacent additions or acreage.
8. Provide runoff calculations for all areas showing acreage, runoff coefficient, inlet time, and storm frequency.
9. Indicate all crests, sags, and street and alley intersections with flow arrows.
10. Show limits of each plan profile sheet.

b. Plan Profile Sheets

1. Show plan and profile of all storm sewers on separate sheets from paving plans.
2. Indicate concrete cushions or embedment where applicable.
3. Specify reinforced concrete Class III pipe unless otherwise noted. Use heavier pipe where crossing railroads, deep fill or heavy loads.
4. Indicate property lines along storm sewer and show easements with dimensions.
5. Show all existing utilities in plan and profile of storm sewers.
6. Indicate existing and proposed ground line and improvements on all street, alley, and storm sewer profiles.
7. Show hydraulic gradient with computations.
8. Show laterals on trunk profile with stations.
9. Number inlets according to the number designation given for the area or sub-area contributing runoff to the inlet.
10. Indicate size and type of inlet on plan view, lateral size and flow line, paving station and top of curb elevation.
11. Indicate quantity and direction of flows at all inlets, stubouts, pipes and intakes.
12. Show future streets and grades where applicable.
13. Show water surface at outfall of storm sewer, velocity, and typical section of receiving water body.
14. Where fill is proposed or trench cut in creeks or outfall ditches, specify compacted fill and compaction criteria.
15. Show size of pipe, length of each pipe size, stationing at one hundred foot intervals in the plan view.
16. Begin and end each sheet with even or fifty foot stationing.
17. Show diameter of pipes, physical grade, discharge, capacity of pipe, slope of hydraulic gradient, and velocity in the pipe in the profile view.
18. Show elevations of flow lines at 100-foot intervals on the profile.
19. Give bench mark information.
20. Show capacities, flows, velocities, etc., of the existing system into which the proposed system is being connected.
21. Show details of all connection boxes, headwalls on storm sewer, flumes or any other item not a standard detail.
22. Provide lateral profiles and where utilities are crossed, show all utilities in profile.
23. Show headwalls and specify type for all storm sewers at outfall.
24. Show if curbing in alleys is needed to add extra capacity.
25. Provide flat grade alleys and streets to discharge into streets.
26. Show curve data for all storm sewers.
27. Tie storm sewer stationing with paving stations.



28. On all dead-end streets and alleys, show grades for drainage overflow path on the plan and profile sheets, and show erosion controls.
29. Specify concrete strength for all structures.
30. Provide sections for road, railroad and other ditches with profiles and hydraulic computations. Show design water surface on profile.

c. Bridge Plans

1. Show the elevation of the lowest member of the bridge and 100-year water surface elevation.
2. Indicate borings on plans.
3. Provide soils report.
4. Show bridge sections upstream and downstream.
5. Provide hydraulic calculations on all sections.
6. Provide structural details and calculations with dead load deflection diagram.
7. Provide vertical and horizontal alignment.

d. Creek Alteration and Channel Plans

1. Show stationing in plan and profile.
2. Indicate flow line, banks, design water surface, and freeboard. Show hydraulic computations.
3. Indicate nature of banks such as rock, earth, etc.
4. Provide cross-sections with ties to property lines and easements.
5. Show side slopes of creek, channels, etc.
6. Specify compacted fill where fill is proposed.
7. Indicate any adjacent alley or street elevations on creek profile.
8. Show any temporary or permanent erosion controls.
9. Indicate existing and proposed velocities.
10. Show access and/or maintenance easements.
11. As necessary, show ground elevations parallel to the top of bank to show how runoff is prevented from overland flow into the creek or channel.

e. Detention and Retention Facilities

1. Show plan view of detention/retention area and outlet structure.
2. Delineate limits of conservation pool, sediment storage area, flood storage pool, and/or freeboard.
3. Indicate size, dimension, total capacity, design discharge and velocity of the outlet structure.
4. Show any erosion control features at the discharge point of the outlet structure.
5. Specify side slopes of basin and outlet structure.

6. Show existing or proposed structures or other facilities down stream of the outlet structure and emergency spillway, and provide information sufficient to show that the downstream facilities will not be inundated or otherwise affected by the discharge from the basin.
7. Indicate locations and quantities of all inflows to the basin.
8. State the design time to empty the basin.

f. Levees

1. Show location, extent, nature, dimensions, etc., of levee embankments and associated interior and exterior drainage facilities.
2. Provide engineering analysis addressing potential erosion of the levee embankments during flood events.
3. Provide engineering analysis of levee embankment stability and seepage through the levee during flood events.
4. Demonstrate that future settlement of the levee embankments will not result in freeboard dropping below the minimum requirements. Provide geotechnical reports showing anticipated levee consolidation.
5. Analyze interior drainage concerns. Identify sources of interior flooding, and extent and depth of such flooding, assuming a joint probability of interior and exterior flooding. Consider capacity of pumps and other drainage devices for evacuating interior waters.
6. Write an operations manual which discusses the flood warning system to trigger closures; closure operations, procedures, and personnel; operation plans for interior drainage facilities; at least an annual inspection program; and maintenance plans, procedures, and frequency.
7. Provide all other information required in Article 7, Section C, and any other information requested or required by the City Engineer and/or the Federal Emergency Management Agency.

2. Floodplain Alteration Plans

The materials listed below shall be submitted as part of the application for a Floodplain Alteration Permit. It is recommended that applicants coordinate the application materials listed below with those needed for other City of Carrollton permits and with the data requirements of the Federal Emergency Management Agency. Such coordination will facilitate staff review and drawings could be combined so as to save the applicant from multiple drawings.

- a. An engineering report consisting of at least:
1. Project description.
  2. Description of the hydrologic and/or hydraulic analyses used, including method used to determine historic rainfall and stream data, soils reports used to determine erosive velocity values, and discharges and water surface elevations for both the design and base floods.
  3. Vicinity map.

4. Evaluation of the "natural floodway" and floodplain limits for the design flood. The "natural floodway" differs from the FEMA "regulatory floodway." The "natural floodway" is established to allow the City of Carrollton to effectively manage flood plain areas. FEMA requirements for the "regulatory floodway" must also be met by applicants.
  5. If hydraulic analyses are being submitted, then a table of values for existing and proposed water surface elevations and velocities must be included.
  6. Documentation that the principle of equal conveyance has been achieved.
  7. Copies of computer input and output data for existing and proposed conditions for both the base flood and design flood discharges.
- b. Engineering drawings consisting of at least:
1. Water surface profile, including channel flow line, existing and proposed water surface elevations, recorded high water marks, and location and number designation of cross-sections.
  2. Plan view on 24" x 36" paper, including
    - a. Scale and north arrow.
    - b. Title block.
    - c. Boundary lines and nearest street intersections.
    - d. Existing and proposed contours.
    - e. Existing and proposed floodplain limits, and limits of the "natural floodway" and the "regulatory floodway."
    - f. Area to be removed from the floodplain or area to be altered.
    - g. Top and toe of fill and/or side slopes and the numerical slope of the fill and/or side slopes labeled.
    - h. Location of all other associated improvements or alterations to the creek and/or floodplain, such as check dams, swales, channel modifications, etc.
    - i. Location of cross-sections.
    - j. Location of all existing and proposed easements and dedications.
    - k. Site vicinity map.
  3. Plots of cross-sections, including:
    - a. Scale.
    - b. Title block.
    - c. Existing and proposed ground elevations.
    - d. Cut and/or fill areas labeled.
    - e. Limits of and numerical values for existing and proposed "n" values.
    - f. Equal conveyance removed from both sides.

**SECTION E. Maintenance Bonds**

The Contractor shall guarantee the work which he does against defective workmanship and materials for a period of two (2) calendar years from the date of final acceptance by the City.

Where defective workmanship and/or materials are discovered requiring repairs to be made under this guarantee, all such repair work shall be done by the Contractor at his own expense within ten (10) calendar days after written notice of such defect has been given to him by the City. Should the Contractor fail to make

repair or correct such defective workmanship and/or materials within ten (10) calendar days after being notified, the City may make the necessary repairs and charge the Contractor with the actual cost of all labor and materials required.

The Contractor shall provide a maintenance bond in the amount of 100% of the contract price, for a period of two (2) years after the date of acceptance of the work to cover his guarantee as set forth above.

## **SECTION F. Appeals and Variance Procedure**

### **1. Appeal**

Any person aggrieved by a decision of the City Engineer or City Manager may appeal from any order, requirement, decision or determination of the City Engineer to the Planning and Zoning Commission. An appeal from a determination of the Planning and Zoning Commission may be made directly to the Court of Appeal.

### **2. Variances**

The Planning and Zoning Commission as established by the City of Carrollton shall hear and decide requests for variances from the requirements of this ordinance.

Variances concerning Development Permits may be issued for the reconstruction, rehabilitation or restoration of structures listed on the National Register of Historic Places or the State Inventory of Historic Places, without regard to the procedures set forth in the remainder of this section.

Variances shall not be issued within any designated natural or regulatory floodway if any increase in flood elevations during the design flood discharge would result unless the increase will result in no negative impacts on adjacent properties and written approval is obtained from impacted property owners.

Variances shall be issued only upon a determination that the variance is the minimum necessary to afford relief considering the flood hazard, drainage problems, and soil loss.

Variance shall be issued only upon meeting all three of the following criteria:

1. A showing of good and sufficient cause.
2. A determination that failure to grant the variance would result in exceptional hardship to the applicant; and,
3. A determination that the granting of a variance will not result in increased flood heights, additional threats to public safety, extra ordinary public expense, create nuisances, cause fraud on or victimization of the public, or conflict with existing local laws or ordinances.

Any applicant to whom a variance for building or renovating in a floodplain is granted shall be given written notice that the structure will be permitted to be built with a lowest floor elevation below the design flood elevation and that the cost of flood insurance will be commensurate with the increased risk resulting from the reduced lowest floor elevation.

In considering variance requests, the Planning and Zoning Commission shall consider all technical evaluations, all relevant factors, standards specified in other sections of this ordinance, and the:

- Danger that materials may be swept onto other lands to the injury of others;
- Danger to life and property due to drainage, flooding, or erosion damage;
- Susceptibility of the proposed facility and its contents to flood damage and the effect of such damage on the individual owner;
- Importance of the services provided by the proposed facility to the community;
- Necessity to the facility of a waterfront location, where applicable;
- Availability of alternative locations for the proposed use which are not subject to flooding damage.
- Compatibility of the proposed use with existing and anticipated development.
- Relationship of the proposed use to the comprehensive plan and flood plain management program of that area.
- Safety of access to the property in times of flood for ordinary and emergency vehicles;
- Expected heights, velocity, duration, rate of rise, and the effects of wave action, if applicable, expected at the site; and,
- Costs of providing governmental services during and after storm events, including maintenance and repair of public utilities and facilities such as sewer, gas, electrical, and water systems, and streets and bridges.

Upon consideration of the factors listed above and the purposes of this ordinance, the Planning and Zoning Commission may attach such conditions to the granting of variances as it deems necessary to further the purposes of this ordinance.

The City Manager shall maintain the records of all appeal actions, including technical information, and report any variances of the floodplain management portions of this ordinance to the Federal Emergency Management Agency upon request.

## ARTICLE 5

### RUNOFF CALCULATIONS

The selection of which method to use for calculating runoff depends upon the size of drainage area contributing runoff at a most downstream point of a project. The "Rational Method" is acceptable for situations in which the drainage area is less than 160 acres. A unit hydrograph method is required for situations with larger drainage areas.

No matter which method is used to calculate runoff, a developer or builder of property greater than one acre in size, or any property that was platted as a part of an overall tract which was greater than one acre in size (includes churches and schools), shall develop the property so that the rate of runoff created by the development as it leaves the property does not exceed the rate of runoff that would have been created if the property had developed as single-family residential property. Article 7, Section D discusses design criteria for detention facilities.

Runoff computations shall be based upon fully developed watershed conditions in accordance with the land use projections in the latest comprehensive land use plan for the City of Carrollton. The design engineer shall size drainage facilities by disregarding the detention effects of upstream property and calculating the runoff as if the off-site property was developed without any detention. If an approved regional detention/retention facility is in operation, the design engineer may size downstream drainage facilities based on consideration of the detention effects of the regional facility.

#### **SECTION A. Procedure for Drainage Areas Less Than 160 Acres**

##### **1. Rational Method**

Computation of Stormwater Runoff for drainage areas less than 160 acres shall be by the "Rational Method," which is based on the principle that the maximum rate of runoff from a given drainage area for an assumed rainfall intensity occurs when all parts of the area are contributing to the flow at the point of discharge. The formula for calculation of runoff by the "Rational Method" is:

(Equation 1)

$$Q = C_f CIA$$

Where: Q = the maximum rate of discharge, expressed in cubic feet per second.

$C_f$  = frequency factor coefficient for adjustment of the rational method C value. This factor varies from 1.00 to 1.25 for the 10-year and 100-year storms respectively.

C = a runoff coefficient which varies with the topography, soil, land use and moisture content of the soil at the time the runoff producing rainfall occurs. This runoff coefficient shall be based on the ultimate use of the land as recommended by the Master Plan for the City of Carrollton and shall be selected from Table 1 herein on the basis of the use shown on land use and zoning map of the Comprehensive Zoning Ordinance for the City of Carrollton. If an area has had a change of Zoning to give the area land use for which the "C" in Table 1 is higher than use shown on land use and zoning maps, the higher "C" factor shall be used.

A = The drainage area, expressed in acres, contributing to the runoff at the point in question. Calculation of the drainage area shall be made from an accurate topographic map, a copy of which shall be submitted with the engineering plans for approval.

I = Rainfall intensity in inches per hour for the time period that it takes for flow from the farthest point of the drainage area to reach the point of design. The rainfall intensity is found by referring to the applicable curves of Figure 1. Time of Concentration or Duration of Rainfall for use in Figure 1 shall be calculated by velocity data shown in Table 2.

Time of concentration is the longest time, without interruption of flow by detention devices, that a drop of water takes to flow from the farthest point of the drainage area to the point of concentration (i.e., the point of design). The time of concentration is composed of the "inlet time" and the flow time in a conduit or channel to the point of design. Equation 2 shows how to calculate the time of concentration.

(Equation 2)

$$T_c = \text{Inlet Time} + \frac{L}{V \times 60 \text{ sec/min}}$$

Where:  $T_c$  = Time of concentration in minutes.

Inlet time = 10 minutes for property zoned multiple family, churches, schools, local business, central business, commercial, or industrial

or

15 minutes for property zoned for parks, cemeteries, agricultural, and single family residential.

or

$$\frac{L}{V \times 60 \text{ sec/min}}$$

L = Length of conduit or channel, in feet.

V = Velocity of flow in conduit or channel, in feet per second.

When designing inlets and laterals, the time of concentration is simply equal to the inlet time. The design engineer will compare the above specified inlet times to the actual calculated inlet time by computing the flow time overland and along the gutter to the first inlet. The Manning equation, along with the velocity information in Table 2 (or other acceptable procedures such as the SCS method), shall be used to determine flow time to the inlet. The design engineer may use the actual calculated or specified inlet time. In no case shall a longer inlet time be used than 10 minutes for multiple family, commercial, churches, schools, industrial and business areas and 15 minutes for parks, cemeteries, agricultural, and single-family areas.

When sizing storm sewers and channels, the time of concentration shall be calculated by adding the actual calculated inlet time (but not greater than the specified inlet times) to the flow time in the conduit and/or channel. The design engineer may use the combined times, as described, or the specified inlet times for storm sewer sizing.

**SECTION B. Procedure for Drainage Areas Greater than 160 Acres.**

For drainage areas in excess of 160 acres where the use of the "Rational Method" does not provide reliable results, the use of a unit hydrograph method shall be made. The use of a unit hydrograph calculation will be based upon standard and accepted Engineering Principles normally used in the Profession subject to the approval of the City Engineer. Acceptable methods include the Soil Conservation Service (SCS) Technical Release Number 55 for drainage areas from 160 acres to 2,000 acres, and SCS's TR20 or the Corps of Engineers HEC-1 models for drainage areas 160 acres or more.

The unit hydrograph method shall be based upon fully developed watershed conditions assuming no effects from the small on-site detention facilities for maintaining the rate of runoff as if the property was developed as single family residential uses. The detention effects of large regional detention facilities can be taken into account in unit hydrograph methods.

Circumstances that may require the use of a unit hydrograph method include sizing open channels, reclaiming floodplains, creating lakes, or building other types of drainage-related facilities on major drainage courses. Design engineers of these types of facilities should be aware that the requirement of designing for fully developed watershed conditions will mean that they will have to calculate these fully developed flows instead of using the flows calculated in the Federal Emergency Management Agency's (FEMA) flood insurance studies for Carrollton. FEMA's flows cannot be used because the flows are based upon existing watershed conditions (For more information, see Article 7 on the sizing of channels and other major drainage facilities and Article 8 for floodplain alteration procedures). Use of the rational method is allowed for design of storm sewers within the project area.



## ARTICLE 6

### DESIGN OF LOCAL DRAINAGE SYSTEMS

#### **SECTION A. Design Storm Frequencies**

The calculations of runoff quantities that must be accommodated in drainage facilities require the selection of the design storm frequency. The design storm frequencies for various drainage structures are given below.

<u>DRAINAGE FACILITY</u>	<u>DESIGN RECURRENCE INTERVAL</u>
Closed Storm Sewer Systems	10-year with 100-year positive overflow for Inlets on Grade in streets such that the depth of flow in the street does not exceed the top of curb.
Closed Storm Sewer Systems and Inlets at Street Low Point or Sag	100-year
Culverts and Bridges	100-year
Concrete-lined Channels	100-year
Earthen Channels	100-year
Levees	Standard Project Flood
Dams Above Natural Ground/Spillways	Spillway design flood varies with the class of structure (see Article 7, Section B).

The approved drainage system shall provide for positive overflow at all low points. The term "positive overflow" means that when the inlets do not function properly or when the design capacity of the conduit is exceeded, the excess flow can be conveyed overland along a grassed or paved course. Normally, this would mean along a street or alley, or shall require the dedications of special drainage easements on private property.

#### **SECTION B. Street and Alley Capacities**

##### 1. Streets

Assuming parkway slopes to be 1/4 inch per foot behind the curbs, the depth of flow in the streets shall not exceed the top of curb. Figure 2 shows the capacity of streets with a straight cross slope that varies from 1/8 inch per foot to 1/2 inch per foot, which are the minimum and maximum allowable street cross slopes. Figures 3 and 4 show the capacity of streets with parabolic crowns.

##### 2. Alleys

The flows created by the 100-year storm shall be contained within the capacity of all paved alleys. Figure 5 shows the capacity of various alley sections.

Alley capacities shall be checked at all alley turns and "T" intersections to determine if curbing is needed or grades should be flattened. Alley sections shall be super-elevated as required at corners and curves to insure that flow remains in the alley through these changes in alignment.

Curbing shall be required for at least 10 feet on either side of an inlet in an alley and on the other side of the alley so that the top of the inlet is even with the high edge of the alley pavement.

3. Finished Floor Elevations in Relation to Alleys, Streets, and Positive Overflows

The first floor elevations of all residential and other structures shall be set at a minimum elevation of the lower of either 1.5 feet above the alley invert or one foot above the top of the street curb elevation, and with positive drainage provided away from the structure. Positive overflow sections shall provide a minimum of 2 feet of freeboard from the overflow invert adjacent to structures and the corresponding first floor elevation of all residential and other structures.

**SECTION C. Placement of Inlets**

Storm sewer inlets shall be built along paved streets at such intervals that the depth of flow, based upon the 100-year storm, does not exceed the top of curb. Inlets shall be located as necessary to remove the flow based on a 10-year storm. If in the opinion of the City Engineer the flow in the gutters would be excessive using the above design criteria, the storm sewers or inlet locations could be altered to relieve adverse conditions.

Inlets shall be placed upstream from an intersection whenever possible. At any intersection, only one street shall be crossed with surface drainage and this street shall be the lower classified street. When an alley intersects a street, inlets shall be placed in the alley whenever flow down that alley would cause the capacity of the intersecting street to be exceeded.

**SECTION D. Inlet Capacities and Sizes**

Figure 6 shows the various types of inlets allowed for use along various kinds of streets. Other types of inlets may be used upon the approval of those inlets by the City Engineer. The minimum inlet size shall be eight feet. Figures 7 through 21 show how to determine the capacity of inlets. No more than 20 feet of inlets shall be placed along one gutter at any given location.

Minimum sizes of laterals shall be 18-inches for use with 8-foot inlets, and 21-inch laterals with 10-foot, 14-foot, and drop inlets, and 24-inch laterals for 20-foot inlets. Where laterals tie into trunk lines, place the laterals on a 60 angle with the trunk line and connect them so that the longitudinal centers intersect.

**SECTION E. Pipe Design Standards**

1. The Manning Equation

Storm sewer conduit shall be sized to flow full. Manning's Equation shall be used to determine the conduit size. Manning's equation is expressed as:

(Equation 3)

$$Q = \frac{1.486}{n} (A) (R)^{2/3} (S)^{1/2} \text{ or } V = \frac{1.486}{n} (R)^{2/3} (S)^{1/2}$$

Where: Q = Flow in cubic feet per second.

V = Velocity of flow in conduit in feet per second.

A = Cross-sectional area of the conduit in square feet.

R = Hydraulic radius of the conduit, which is the area of flow divided by the wetted perimeter ( $R = A/P$ ).

S = Slope of the hydraulic gradient.

n = Roughness coefficient of the conduit.

P = Wetted perimeter.

Figure 22 is a graphical solution of Manning's Equation, which allows sizing of concrete pipe, assuming an "n" value of 0.013.

## 2. Minimum and Maximum Velocities in Pipes

The minimum velocities in conduit shall be 2.5 feet per second. The minimum slopes for various pipe sizes that will maintain this minimum velocity are given in Table 3. The recommended maximum velocities of flow in the conduit and channels are given in Table 4.

The maximum discharge velocities in the pipe shall also not exceed the permitted velocity of the receiving channel or conduit at the outfall to prevent erosive conditions, as shown in Table 4. The maximum outfall velocity of a conduit in partial flow shall be computed for partial depth and shall not exceed the maximum permissible velocity of the receiving channel unless controlled by an appropriate energy dissipater (e.g. stilling basins, impact basins, riprap protection).

## 3. Roughness Coefficients for Conduits

In general, stormwater shall be carried in concrete pipe conduit, but other types of conduit can be used to carry stormwater. However, prior permission to use metal conduit must be obtained from the City Engineer. Table 5 shows recommended roughness coefficients for various types of conduits. If, in the opinion of the design engineer, other values for the roughness coefficient should be used, the different value can be used with the permission of the City Engineer. Appropriate notes of the approved roughness coefficient shall then be shown on the engineering plans.

4. Hydraulic Gradient of Conduits

Conduits must be sized and slopes must be set such that runoff flows smoothly down the drainage system. To insure this smooth passage, the hydraulic gradient must be at the proper elevations.

The proper starting elevation of the hydraulic gradient shall be set according to the applicable criteria listed below:

1. When a proposed conduit is to connect to an existing storm sewer, the hydraulic gradient of the proposed storm sewer should start at the elevation of the hydraulic gradient of the existing storm sewer based on an evaluation of the existing storm sewer with respect to the requirements found in this ordinance. This criterion will be used for existing systems whether or not they are designed in accordance with this ordinance.
2. When a proposed conduit enters an open channel, creek, or flood control sumps, the hydraulic gradient of the proposed conduit should start at the 10-year water surface elevation of the channel or creek when the ratio of the drainage area of the receiving creek (at the development) to the development area is 15 or greater. For ratios of less than 15, the 100-year water surface will be used on the receiving creek.

Not only is it important to use the proper starting elevation for the hydraulic gradient, but proper hydraulic gradient elevations must be maintained for the length of the conduit. The inside top of the conduit should be at or below the hydraulic gradient. However, effort should be made to keep the top of the pipe as close to the hydraulic gradient as possible so that deep excavations to lay pipe are not required.

When the conduit is flowing partially full, the hydraulic gradient shall be shown at the inside crown of the conduit.

The hydraulic gradient shall be kept two feet below the top of curb. If this cannot be obtained, the hydraulic gradient shall be at least  $1.5 V_1^2/2g$  feet below the gutter line, where  $V_1$  is the velocity in the lateral.

5. Minor Head Losses

When establishing the hydraulic gradient of a storm sewer, minor head losses at points of turbulence shall be calculated and included in the computation of the hydraulic gradient.

Entrance Losses

Entrance losses to a closed storm sewer system from an open channel or lake shall be calculated using Equation 4.

(Equation 4)

$$H_L = K_e \frac{V_1^2}{2g}$$

Where:  $H_L$  = Head loss in feet.

$V_1$  = Velocity in the downstream pipe in feet per second.

$K_e$  = Head loss coefficient (see Table 6).

The resulting hydraulic gradeline shall be compared to inlet control conditions for the storm sewer as described in Section F. The higher of the two values will be used as the controlling upstream hydraulic grade line.

#### Expansion Losses

For pipe size expansions, head loss shall be calculated using the following equations:

(Equation 5)

$$H_L = \left(1 - \left(\frac{D_1}{D_2}\right)^2\right)^2 \frac{V_1^2}{2g}$$

Where:  $H_L$  = Head loss in feet.

$V_1$  = Upstream velocity in feet per second.

$D_1$  = Upstream pipe diameter.

$D_2$  = Downstream pipe diameter.

#### Manhole and Bend Losses

Head losses associated with manholes for pipe direction changes and bends in pipes of equal diameter shall be calculated using:

(Equation 6)

$$H_L = K_b \frac{V_2^2}{2g}$$

Where:  $H_L$  = Head loss in feet.

$V_2$  = Velocity in the downstream pipe in feet per second.

$K_b$  = Head loss coefficient from Table 7.

### Junction Losses

Head losses associated with wye connections or manholes with branch laterals entering the main line can be calculated by using Equation 7.

(Equation 7)

$$H_L = \frac{V_2^2}{2g} - K_j \frac{V_1^2}{2g}$$

Where:  $H_L$  = Head loss in feet.

$V_1$  = Velocity in the upstream pipe in feet per second.

$V_2$  = Velocity in the downstream pipe in feet per second.

$K_j$  = Head loss coefficient from Table 7.

### 6. Storm Sewer Laterals

Laterals for storm sewer systems shall be sized to control the flooding depth at the inlets. The depth shall not exceed the limits previously established for storm sewer systems. Calculation of the flooding depth shall be determined based on the addition of the velocity head of the lateral to the computed HGL:

$$ELEV = HGL + \frac{V_L^2}{2g}$$

This calculated elevation shall be compared to the elevation determined based on inlet control nomographs as developed by the Department of Transportation. The highest of the two elevations shall be used to establish the capacity of laterals and the corresponding depth of flooding.

### 7. Outfalls to Open Channels and Lakes

The flow lines of storm sewer conduits that discharge into open channels shall match the flow line of the channel. One exception to this requirement of matching the flow line is when a storm sewer discharges into a concrete-lined channel, or when the outfall is submerged below the normal water surface of a lake. In the case of a pipe discharging to a lined channel, the outlet must be below the top of the channel lining. The second exception pertains to storm sewer discharge that must cross wide floodplain areas. Under this condition, the storm sewer could discharge into a lined ditch which would convey runoff to the flow line of the channel without creating an erosive condition. Permissible velocities within the ditch will be based on the type of lining used and the velocities provided in Table 4. Flumes to bring the discharge down to the flow line of earthen creeks shall not be permitted. Drop structures shall be allowed upon written approval of the City Engineer.

The velocity at the discharge end of the conduit shall be computed based on partial flow depth and shall be sufficiently low so as to not cause downstream erosion problems. Table 4 shows the maximum velocities allowed in various types of channels, which are then the maximum discharge velocities at storm sewer outfalls.

In some circumstances, the configuration of the storm sewer in relation to the flow line of the creek may cause excessive velocities to be reached unless provisions are made to slow the velocity. One recommended method of slowing the velocity is to have the last length of pipe (a length of at least ten times the diameter) be on a slope that will reduce the partial flow outlet velocity to the values shown in Table 4 for the receiving stream. Stilling basins shall also be allowed to reduce discharge velocities.

The discharge pipe shall also intersect minor creeks at an angle not to exceed 60 degrees. Minor creeks are defined as those creeks, channels, or drainageways where the distance from the pipe outlet to the opposite creek bank at the bottom of the channel is twenty (20) feet or less. Pipes may intersect major creeks (greater than 20 feet to opposite bank) at a 90-degree angle. The City Engineer may require that pipes intersect major creeks at an angle not to exceed 60 degrees, when a 90-degree angle would result in an erosive condition.

Figure 23 shows how a storm sewer should be configured to discharge into a creek.

7. Easements for Enclosed Storm Sewers and Positive Overflow Areas

All storm sewer conduits to be dedicated to the City of Carrollton shall be located in an easement dedicated to the City of Carrollton at the time of final platting of the property. The easement shall be at least 15 feet wide for storm sewers or wider if the City Engineer requires it for maintenance or other purposes. Special drainage easements on private property shall be a minimum of 10 feet wide or wider if the City Engineer requires it for maintenance or other purposes. No fences, buildings or other structures and improvements shall be placed within these dedicated easements.

**SECTION F. Culvert Design Standards**

Culverts shall be designed in accordance with the Texas Highway Department Hydraulic Manual, Chapter 4 - Culverts. The calculation of hydraulic grade lines will consider both inlet and outlet control for the culvert. Starting water surface elevations for gradeline calculation will be the same as required for storm sewers; see Section E.

## ARTICLE 7

### SPECIAL DRAINAGE FACILITIES

#### SECTION A. Channels

##### 1. Channel Design

Open channels may be used instead of enclosed systems when the drainage area of contributing flow to the channel is greater than 160 acres. Open channels shall not be permitted when the drainage area is less than 160 acres. Table 4 shows the maximum velocities allowed for certain types of channels. Roughness coefficients for the design of open channels are provided in Table 8. The following criteria shall be used in determining the nature of the open channel.

- For channels with a contributing drainage area of 160 acres or greater:

- a. Channels may be left in their natural state provided that the channel velocities are 6.0 feet per second or less.
- b. If the natural channel is to be replaced by an improved channel, the flow from the 100-year design flood must be contained within the improved channel while allowing for one foot of freeboard. An improved channel shall meet the floodplain alteration regulations presented in Article 8.
- c. Improved channels shall include a lined section if the design velocity is greater than six feet per second. Lining types such as concrete, rock walls and gabions, may be used upon approval of the City Engineer. Improved channels with design velocities of less than the permissible velocities shown in Table 11 may be earthen if the channels are revegetated properly.
- d. For lined channels, all of the channel bottom and at least the first three feet (vertical height) of the side slopes up from the channel bottom shall be lined, unless approved by the City Engineer.
- e. Earthen sides above the lined section or totally earthen channels shall be on at least a four horizontal to one vertical slopes and shall have approved ground cover to prevent erosion.
- f. Unless shown to be feasible in a soils report sealed by a registered professional engineer in the State of Texas, and approved by the City Engineer, improved channels shall have minimum side slopes of:
  - 4 feet horizontal to 1 foot vertical for earthen grassed side slopes.
  - 1.5 feet horizontal to 1 foot vertical for side slopes in rock.
- g. The developer or owner shall use low maintenance vegetation for vegetative cover, as approved by the City Engineer prior to planting. The selection of materials shall comply with either the current ground cover listing for North Central Texas furnished through the Texas Agricultural Extension Service or Table 9 in this ordinance.



- h. The developer/owner shall provide a drainage easement and a required maintenance easement (see paragraph 4 below) which shall be dedicated to the City of Carrollton as a permanent drainage right-of-way and open space corridor.
- i. Channel improvement shall not include concrete pilot channels which do not meet the requirements of item A.1.d., unless approved by the City Engineer.

2. Erosion Prevention

All channel sections must consider and account for channel stabilization in their design. This requirement pertains to all sections whether they are left in their natural condition or are modified in any manner. Three sets of requirements are provided depending upon the relationship of the existing channel to the limits of the developer/owner's property boundaries. The City Engineer shall have the discretion to require the implementation of the portion of these requirements as deemed necessary, depending on the specifics of the property being developed or improved.

- a. In cases where the entire channel section is contained within the limits of the developer/owner property boundaries. The developer/owner shall:
  - 1. Provide for an improved stabilized channel cross-section which reduces all velocities to 6.0 fps or below for vegetated channels. The channel improvements must meet all requirements of this ordinance.
  - 2. For vegetated channel sections with channel velocities ranging from 6 to 8 fps, construct grade control structures within the channel and overbank areas to prevent erosion. Grade control structures shall have a minimum effective depth of 3.0 feet below existing or proposed grades with an adequate number of structures to prevent less than 1 foot of degradation.
- b. In cases where the property boundary follows the centerline of the channel or incorporates only a portion of the channel cross-section, the developer/owner shall:
  - 1. Determine the design section required to provide for an improved stabilized channel cross-section which reduces all velocities to 6.0 fps or below for vegetated channels. The design channel section must meet all requirements of this ordinance.
  - 2. The design section may include vegetated channel sections with channel velocities ranging from 6 to 8 fps, provided that grade control structures are included within the channel and overbank areas to prevent erosion. Grade control structures shall have a minimum effective depth of 3.0 feet below existing or proposed grades with an adequate number of structures to prevent less than 1 foot of degradation.
  - 3. The developer/owner shall construct the portion of the design improvements required on their property for the ultimate channel design. The City Engineer shall have the discretion to determine the portion of the design improvements to be constructed by the developer/owner. In most instances, the developer/owner shall construct one-half of the improvements on their property.
  - 4. If grade control structures are incorporated into the design, the developer/owner shall coordinate with adjacent owners in order to construct

these features in their entirety at the time of the initial portion of the channel improvements.

5. The developer/owner shall provide for a drainage easement and access/maintenance easement consistent with the portion of the improvements provided.
- c. In cases where the developer/owner owns property adjacent to channel or floodplain areas but does not own a portion of the channel or floodplain area, the developer/owner shall (at the discretion of the City Engineer):
  1. Determine the channel improvement configuration necessary to meet the requirements of item (2a) above and
  2. Shall provide a dedicated easement to the city for the portion of this future improvement configuration, including necessary maintenance and access easement, which will include the developer/owner property.

3. Starting Water Surface Condition

When performing hydraulic analyses for channel or drainageway design, the starting water surface shall be based on the following criteria.

- a. When the ratio of the drainage area of the receiving creek (at the confluence location) to the drainage area of the channel or drainageway being designed is 15 or greater, the 10-year water surface of the receiving creek shall be used as the starting water surface for hydraulic design calculations. For creeks where the 10-year water surface is not available, the slope-area method will be used for starting design calculations.
- b. When the ratio of the drainage area is less than 15, the 100-year elevation on the receiving creek shall be used as the starting water surface for design calculations.

4. Easements Required for Open Channels

Drainage and/or floodway easements for all open channels, creeks and flumes shall be dedicated to the City of Carrollton. Easements shall encompass all areas having a ground elevation below the higher of one foot above the water surface elevation associated with the design flood or the top of the high bank or channel edge. No fences, buildings, or other structures which could impede flow shall be placed within this dedicated drainage easement. In all cases, the easement shall also include at least a 15-foot wide maintenance strip along both sides of the channel or, if the City Engineer so allows, at least a 20-foot wide maintenance strip along one side of the channel. Streets, alleys, bike paths, etc., alongside the channel can serve as all or part of the maintenance easement.

Drainage easements for flumes shall be located with sufficient width to permit future maintenance accessibility, and in no case shall be less than 15 feet wide.

**SECTION B. Lakes and Dams**

In the event that a property owner or developer desires to modify an existing pond or lake or desires to impound stormwater by filling or constructing an above-ground dam, thereby creating a lake, pond, lagoon or basin as part of the planned development of that property, the criteria listed below shall be met before City

approval of the impoundment can be given. Ponds or lakes, created by excavation of a channel area without erecting a dam above natural ground elevation or instream, low water checkdams are also subject to the criteria listed below, with the exception of spillway capacity requirements. The City Engineer has the final authority to determine the design criteria for a proposed dam, checkdam or excavated lake. The requirements of the State of Texas must also be met for the construction of dams, lakes, and other impoundments.

The design criteria for a dam is dependent on the size and hazard classification of the dam. The size and hazard classification will be based on Chapter 12 of the Texas Water Code and will be determined by the City Engineer based on information furnished by the owner. The following criteria will be used to classify a dam:

1. Size

The classification for size is based on the height of the dam and storage capacity, whichever gives the larger size category. Height is defined as the distance between the top of the dam (minus the freeboard) and the existing streambed at the downstream toe. Storage is defined as the maximum water volume impounded at the top of the dam (minus the freeboard).

Size Classification

Impoundment

Category	Storage (acre-feet)	Height (feet)
Minor	<100	<10
Small	≥100 and < 1,000	≥10 and < 40
Intermediate	≥1,000 and < 50,000	≥40 and < 100
Large	≥50,000	≥100

2. Hazard Potential

The hazard potential for a dam is based on the potential for loss of human life and property damage downstream from a dam in the event of failure. The following categories will be used:

Hazard Potential Classification

<u>Development</u> Category	Loss of Life (Extent of Development)	Economic Loss (Extent of
Low	None expected (No permanent structures for human habitation)	Minimal (Undeveloped to occasional structures or agriculture)

Hazard Potential Classification

<u>Development)</u>	<u>Category</u>	<u>Loss of Life (Extent of Development)</u>	<u>Economic Loss (Extent of</u>
	Significant	Possible, but not expected (No urban developments and no more than a small number of inhabitable structure	Appreciable (notable agricultural, industry, or commercial development)
	High	Expected (Urban development or large number of inhabitable structures)	Excessive (Extensive public, industrial, or agricultural development)

3. Spillway Design Flood

The classification of a dam based on the above criteria will be used to determine the Spillway Design Flood (SDF). The total capacity of a dam structure, including principal and emergency spillways, shall be adequate to pass the SDF without exceeding the top dam elevation at a minimum. The SDFs for various dam classifications are as follows:

Spillway Design Flood

<u>Hazard</u>	<u>Size</u>	<u>SDF</u>
Low	Minor	100-year
	Small	1/4 PMF
	Intermediate	1/4 PMF to 1/2 PMF
	Large	PMF
Significant	Small	1/4 PMF to 1/2 PMF
	Intermediate	1/2 PMF to PMF
	Large	PMF
High	Small	PMF
	Intermediate	PMF
	Large	PMF

In all cases, the minimum principal spillway design capacity is the 100-year design flood. In certain cases, a dam breach analysis may be required to determine the proper classification of the structure. For all structures requiring a spillway design flood equal to the PMF, a dam breach analysis is required to determine the downstream consequences of a failure. All dams designed for a SDF of 1/2 PMF or less shall be constructed with a minimum freeboard of two feet above the SDF elevation.

4. Additional Design Requirements

- a. An engineering plan for such construction, accompanied by complete drainage design information and sealed by a registered professional engineer, shall have been approved by the City of Carrollton;
- b. The spillway and any emergency overflow areas shall be located so that flood waters will not inundate any buildings, roadways, or other structures.
- c. All Federal, State and County laws pertaining to impoundment of surface water shall have been complied with, including the design construction and safety of the impounding structure. Copies of any Federal, State, and County permits issued for the proposed impoundments shall be submitted to the City Engineer.
- d. Any existing structure, which is included in the project area shall be improved to comply with the applicable Federal, State, County and City safety requirements for structures.
- e. Before removing, enlarging, or altering any existing lake, the Owner will furnish a study of the effects of the alteration upon flooding conditions both upstream and downstream. The study shall be prepared by a professional Engineer and submitted to the City for approval prior to making the proposed alteration. Compensatory storage shall be provided in some manner such that equal or comparable flood retention capacity is maintained.
- f. Any improvements to existing dams or lakes or construction of new impoundments shall be made at the expense of the developer, prior to acceptance of the adjacent street, utilities and drainage improvements as provided for under the Subdivision Ordinance.

5. Maintenance and Liability Criteria

- a. The owner or developer shall have agreed to retain private ownership of the lake, pond, or lagoon or basin constructed and to assume full responsibility for the protection of the general public from any health or safety hazards related to the lake, pond, or lagoon constructed.
- b. The owner or developer shall have agreed to assume full responsibility for the maintenance of the lake, pond, or lagoon or basin constructed. The owner or developer shall keep the Director of Public Works advised of the current responsible agent for this maintenance.

**SECTION C. Levees**

In the event that developers or owners wish to build levees to protect an area from flooding, applicable FEMA and State of Texas guidelines and the following criteria apply:

1. Levees shall be designed to have four feet of freeboard above the Standard Project Flood for the fully developed watershed flows.
2. Levees shall be designed according to the Corps of Engineers design criteria whether or not they are federally authorized levees.

3. Levee systems shall be designed with interior drainage systems to prevent flooding from local runoff contained within the system for the 100-year design flood.
4. Levee systems shall have written operation procedures that address gate closure conditions and emergency warning plan. A copy of these procedures shall be furnished to the City Engineer and the Director of Public Works.
5. Automated gate closure systems shall have power from two independent sources and shall be capable of being operated manually.
6. Ring levees protecting individual structures proposed for construction after the enactment date of this ordinance shall not be permitted.
7. All new levee systems shall have permanent positive closures to the required design elevation. Temporary closures involving sandbagging or other procedures requiring manual operations shall not be permitted.
8. Provisions shall be made for ensuring the permanent maintenance of levees either by a flood control district or similar governmental organization or by the existing property owner and all future owners, heirs, or assigns.
9. Additional plan requirements include water surface profiles for the design flood and SPF; top of levee profile, definition of interior drainage facilities, including pump station and ponding areas; location of gravity outlets, gatewells and closure structures; and elevation-duration data on the receiving system.

**SECTION D. Detention and Retention Facilities**

As previously described in Article 5 of this ordinance, runoff rates for all land uses shall be limited to the rates that would be produced from single family residential areas. This requirement also applies to the development of sites as churches, schools, and other institutional uses. Detention/retention facilities to reduce runoff rates will be provided within approved levee districts unless the District can demonstrate, with technical data, that adequate detention/retention storage is provided in dedicated sumps and storage areas to offset the impacts of developments to runoff rates equal to a single-family residential rate. Detention/retention facilities shall be designed for the 100-year design flood according to the following criteria.

1. The minimum amount of storage volume of the detention basin shall be that volume required to reduce runoff rate to a single-family rate. Dedicated detention/retention basins shall also include an additional one foot of freeboard and two feet of sediment storage. The volume of runoff storage for drainage areas greater than 160 acres shall be computed using unit hydrograph procedures. Acceptable unit hydrograph procedures include the Soil Conservation Service Dimensionless Unit Hydrograph and Snyder's Unit Hydrograph. Manual methods or use of the computer programs TR20, HEC-1, and NUDALLAS are allowed for runoff hydrograph computation and flood routings.

For drainage areas less than 160 acres, the above methods are recommended; however, an approximate routing method based on the rational formula is allowable, as outlined in Figure 24.

2. Detention areas in parking lots shall not be:
  - In required parking spaces but in extra spaces.
  - Behind speed bumps unless the speed bumps are made with reinforced concrete.

- Deeper than six inches unless warning signs are posted.
- 3. Drainage easements shall be provided for all regional detention/retention facilities and for other detention/retention facilities where two or more owners are involved.
- 4. Detention/retention facilities shall be designed to empty in less than 24 hours, unless it is also serving as an erosion control facility.
- 5. Detention/retention facilities shall not be counted as an erosion control technique unless (1) the basins are designed to empty a minimum of 24 hours from the storm event and (2) adequate sediment storage areas in the basin have been set aside and are maintained. Other municipal ordinances give additional details as to how to design multi-purpose detention/retention facilities.
- 6. Detention/retention facilities shall be maintained by the owner unless the facilities are dedicated to the City of Carrollton.

**SECTION E. Flumes**

The use of flumes is not recommended for widespread use. Flumes shall not be permitted when the purpose of a permanent flume is to carry runoff down the sides of earthen channels. A flume may be used to direct overflow runoff along property lines until the runoff can be intercepted by streets or conduit flows. Flumes crossing sidewalks shall be covered or bridged such as to minimize danger to pedestrians.

**SECTION F. Connections from Buildings to Storm Sewers**

Drainage from residential areas, such as roof tops, should be allowed to flow overland before joining the storm sewer system.

Seepage into basements or sub-surface structures that is pumped to ground level, seepage from springs, and runoff from roof drains on non-residential buildings that would flow onto or across driveways, sidewalks, or other areas commonly crossed by pedestrians can create hazards or nuisances to pedestrians. Thus, if hazards or nuisances would be created, the basement and rooftop drains shall be tied directly to the nearest storm sewer, provided that pumped lines from basements have back flow preventers and the water is uncontaminated.

## ARTICLE 8

### FLOODPLAIN GUIDELINES

#### SECTION A. Lands to Which This Article Applies

A person shall comply with the requirements of this article for floodplain areas before making substantial improvements to or increasing the outside dimensions of an existing structure or developing land within the design flood line of a creek or stream having a contributing drainage area of 160 acres or more, whether or not the land has been formally designated as a floodplain. Floodplain areas shall also include all areas inundated by the design flood and shown as Areas of Special Flood Hazard on the Flood Insurance Study's maps.

#### SECTION B. General Floodplain Regulations

##### 1. Permitted Uses of Floodplain Areas

To minimize possible losses of life and property, the following uses are permitted in a floodplain area provided they are also permitted in the underlying zoning district:

- Farm or ranch;
- Local utilities, electrical substation, water reservoir or pumping station, and water treatment plant;
- Public park or playground, private recreation club or area, private community center, and golf course;
- Outside commercial amusement approved by a specific use permit;
- Helistop approved by a specific use permit; and
- Radio, television, or microwave tower, and amateur communications tower with a special use permit.

Structures customarily associated with the above uses may be constructed within a floodplain area only if the proposed structure meets the same engineering requirements applicable to filling in a floodplain (See Article 8.C).

Open private recreation clubs or areas and private community centers, without exterior walls which would incur structural damage during flood conditions, are permitted in floodplain areas. Private facilities listed above, with enclosed walls that would incur damage, are not permitted in floodplain areas.

Uses and structures other than those mentioned above shall not be permitted in floodplain areas.

##### 2. Residential Construction

New construction in reclaimed floodplain areas and "substantial improvements" of any existing residential structure in floodplain areas shall have the lowest floor, including



basements or fully enclosed areas of any new or "substantial improvement" construction, elevated to at least two feet above the design flood elevation.

Fill elevations shall be one foot above the elevation of the design flood. Incremental improvements, either at one time or over a period of time, the cumulative cost of which equals or exceeds 50 percent of the market value at the time of the first improvement, shall be considered as a "substantial improvement." New residential structures or "substantial improvements" on stilts or behind ring levees serving individual lots shall not be permitted.

Improvements to an existing structure that increase the outside dimensions, but do not result in a "substantial improvement," must meet the requirements of Article 8.C.

Table 10 presents a synopsis of the requirements for residential construction in floodplain areas.

### 3. Non-residential Construction

New construction in reclaimed floodplain areas and "substantial improvement" of any existing commercial, industrial, or other non-residential structure in floodplain areas shall either have the lowest floor, including basements of any new or "substantial improvement" construction, elevated to at least two feet above the design flood elevation; or, together with attendant utility and sanitary facilities, shall:

- Be floodproofed so that below two feet above the design flood elevation the structure is watertight, with walls substantially impermeable to the passage of water;
- Have structural components capable of resisting hydrostatic and hydrodynamic loads and effects of buoyancy; and
- Be certified by a registered professional engineer or architect that the standards of this subsection are satisfied. Such certifications shall be provided to the official set forth in Article 4, Section A.1.

Incremental improvements, either at one time or over a period of time, the cumulative cost of which equals or exceeds 50 percent of the market value at the time of the first improvement, shall be considered as a "substantial improvement." Improvements to an existing commercial, industrial or other non-residential structure that increase the outside dimensions, but do not result in a "substantial improvement," must meet the requirements of Article 8.C.

Table 10 presents a synopsis of the requirements for nonresidential structures in floodplain areas.

### 4. Manufactured Homes

- a. All manufactured homes shall be anchored to resist flotation, collapse, or lateral movement by providing over-the-top and frame ties to ground anchors. Special requirements shall be that:
  - Over-the-top ties be provided at each of the four corners of the manufactured home, with two additional ties per side at intermediate locations, with manufactured homes less than 50 feet long requiring one additional tie per side;

- Frame ties be provided at each corner of the home with five additional ties per side at intermediate points, with manufactured homes less than 50 feet long requiring four additional ties per side;
  - All components of the anchoring system be capable of carrying a force of 4,800 pounds; and,
  - Any additions to the manufactured home be similarly anchored.
- b. For all new manufactured homes, new manufactured home parks and manufactured home subdivisions; for expansions to existing manufactured home parks and manufactured home subdivisions; for existing manufactured home parks and manufactured home subdivisions where the repair, reconstruction or improvement of the streets, utilities and pads is planned; and for manufactured homes not placed in a manufactured home park or manufactured home subdivision; for new manufactured homes moved into an old site in an existing manufactured home park; and for substantial improvements to a manufactured home, require that:
- Stands or lots are elevated on compacted fill so that the lowest floor of the manufactured home will be at least two feet above the design flood elevation;
  - Adequate surface drainage and access for a hauler are provided; and,
  - No new manufactured homes shall be placed in a floodplain, except on a pad site created by compacted fill in an existing manufactured home park, in which the new fill pad site is elevated to the design flood elevation.

Manufactured homes may be supported to the required 2 feet above the design flood elevation by stands or foundation features as accepted by FEMA.

Table 10 overviews the requirements for placing manufactured homes in flood hazard areas.

## 5. Recreation Vehicles

Recreational vehicles located on a site within a designated floodplain area shall (i) be on the site for fewer than 180 consecutive days and (ii) be fully licensed and ready for highway use, or (iii) meet the elevation and anchoring requirements for "manufactured homes" outlined in this section. A recreational vehicle is ready for highway use if it is on its wheels or jacking system, is attached to the site only by quick disconnect type utilities and security devices, and has no permanently attached additions.

## 6. Streets, Parking Lots, and Bridges

The top of curb of all new streets to be built in reclaimed floodplain areas shall be at least one foot above the design flood elevation. The low beam of all new bridges to be constructed across floodplains shall be a minimum of one foot above the design flood elevation. All new private bridges to individual homes shall have their low beams at one foot above the design flood elevation. Parking lots associated with residential, commercial and industrial uses in reclaimed floodplain areas shall be at least at the design flood elevation. Parking lots for

public parks or playgrounds, private recreation club or area, private community center and golf courses may be located below the design flood elevation.

7. Utilities

All new and replacement water supply systems, sanitary sewer facilities, and other public utilities shall be designed to minimize or eliminate flood damage and infiltration of flood waters into the system.

8. Fences

Fences (Private and Public Screening) shall be constructed such that blockage of surface water flow does not occur. Fences shall not be allowed in floodplain area or within dedicated easements. This includes the requirement that erosive conditions shall not be created around, under or near a fence structure.

9. Additional Construction Standards for Structures

All improvements and construction permitted in a floodplain area must comply with the following requirements:

- a. Structures must be securely anchored to the foundation to prevent flotation and collapse during inundation and designed to prevent damage to nonstructural elements during inundation.
- b. Thermal insulation used below the first floor elevation must be of a type that does not absorb water.
- c. Adhesives must have a bonding strength that is unaffected by inundation.
- d. Doors and all wood trim must be sealed with a waterproof paint or similar product.
- e. Mechanical, electrical, and utility equipment shall be located above the design flood elevation. Water heaters, furnaces, electrical distribution panels, and other critical mechanical or electrical installations must not be placed in basements. Electrical circuits for basements shall be separate from circuits serving floors above the basement, and circuits for basements shall be installed lowered from above.
- f. Basements are permitted for non-residential structures only if they are designed to preclude inundation by the design flood elevation, either by:
  1. The elimination of exterior openings below the design flood elevation; or
  2. The use of water-tight closures, such as bulkheads and flood shields. However, no basements are permitted in soils whose permeability meets or exceeds the minimum local standards of permeability established for the installation of individual sewage disposal systems.
- g. Plywood used at or below the lowest floor elevation must be of an "exterior" or "marine" grade and of a water-resistant or waterproof variety.

- h. Wood flooring used at or below the lowest floor elevation must be installed to accommodate a lateral expansion of the flooring, perpendicular to the flooring grain, without incurring structural damage to the building.
- i. Basement ceilings for non-residential structures must be of sufficient wet strength and be so installed as to survive inundation.
- j. Paints or other finishes used at or below the lowest floor elevation must be capable of surviving inundation.
- k. All air ducts, large pipes and storage tanks located at or below the lowest floor elevation must be firmly anchored to prevent flotation.
- l. Tanks must be vented at a location above the design flood elevation.

**SECTION C. Floodplain Alterations**

As stated previously in Article 8, Section B, no new construction is allowed in floodplain areas, but construction is allowed in those areas that can be reclaimed from the floodplain. The City of Carrollton has adopted a "natural floodway" that differs from the "regulatory floodway" established by FEMA. The "natural floodway" consists of the natural channel and floodplain that is effective in conveying the design flood. Areas of ineffective flow around bridges, topographic constrictions, and other constrictions are excluded from the "natural floodway." The effective flow area and limits of the "natural floodway" are determined using 4:1 flow expansions downstream of constrictions and 1:1 flow expansions upstream of constrictions. Figure 25 displays an example of effective flow areas at a typical bridge location.

A Floodplain Alteration Permit for floodplain reclamation or other types of alterations shall be allowed only if all of the following criteria are met:

- 1. Alterations of the floodplain and "natural floodway" shall not increase the water surface elevation of the design flood of the creek.
- 2. Alterations shall be in compliance with FEMA guidelines.
- 3. Alterations of the floodplain shall not create an erosive water velocity on or off-site.
- 4. Alterations of the floodplain shall not significantly increase downstream discharges.
- 5. Alterations within the CDC Regulatory Zone shall be in compliance with Article 9 of this Ordinance.
- 6. The effects of existing improvements or public and private improvements for which a future commitment has been made by the City of Carrollton or county, state, or federal agencies, shall be used in determining water surface elevations and velocities.
- 7. Any alteration of floodplain areas shall not cause any additional expense in any current or projected public improvements.
- 8. The floodplain shall be altered only to the extent permitted by equal conveyance on both sides of the natural channel. The right of equal conveyance applies to all owners and uses, including greenbelt, park areas, and recreational usages. Owners may relinquish their right to equal conveyance by providing a written agreement to the City of Carrollton.

9. Maximum slopes of filled areas shall not exceed three to one. Slopes of any excavated areas not in rock shall not exceed four to one.

Fill slopes, vertical walls, terracing, and other slope treatments may be considered provided no unbalancing of stream flow results and only as a part of a grading permit application.

10. A grading permit shall be required so that proper provisions for protecting against erosion losses will be made.

These criteria shall be met before a Floodplain Alteration Permit can be issued for a proposed project. Typical projects requiring a Floodplain Alteration Permit include placing fill whether or not it actually raises the property out of the floodplain, constructing a dam, straightening channel sections, making improvements, substantial or otherwise, to existing structures in a floodplain in which the existing outside dimensions of the structure are increased, and temporary storage of fill materials, supplies, and equipment.

The required submittals for a Floodplain Alteration Permit are listed in Article 4, Section D.2. In general, the information needed for the application can be obtained by running a backwater model, such as HEC-2, and a flood routing model, such as TR-20 or HEC-1. Both models shall be run by permit applicants. The backwater information shall be used to determine that upstream water surface elevations and erosive velocities have not increased. Starting water surface conditions for backwater calculations are outlined in Article 7, Section A.2. Flood routing information shall be used to insure that the cumulative effects of the reduction in floodplain storage of flood waters will not cause downstream increases in water surface elevations and erosive velocities.

Applicants can obtain copies of the existing conditions backwater models and flood routing where available from the City Engineer. The City Engineer shall keep the models current with modifications to the floodplain.

#### **SECTION D. Verification of Floodplain Alterations.**

Prior to final acceptance by the City of utilities and street construction for projects involving floodplain alterations or adjacent to defined floodplains, creeks, channels and drainageways, a certified statement shall be prepared by a Registered Public Surveyor showing that all lot elevations, as developed within the subject project, meet or exceed the required minimum finished floor elevations shown on the final plat of the subdivision. This certification shall be filed with the City Engineer.

In addition, at any time in the future when a building permit is desired for existing platted property which is subject to flooding or carries a specified or recorded minimum finished floor elevation, a Registered Public Surveyor shall survey the property prior to obtaining a building permit. The certified survey data showing the property to be at or above the specified elevation shall be furnished to the City Engineer for approval. Certificate of compliance with the provisions of this ordinance pertaining to specified finished floor elevations shall be required.

The owner/developer shall furnish, at his expense, to the City Engineer sufficient engineering information to confirm that the minimum floor elevations proposed are as required by this paragraph. Construction permits will not be issued until (1) a conditional letter of map revision or amendment has been issued by FEMA, and (2) lots and/or sites are certified by a Registered Public Surveyor and are elevated from the floodplain according to the FEMA-approved revisions to the floodplain and the requirements of this ordinance.

## ARTICLE 9

### SPECIAL PROVISIONS

#### TRINITY RIVER CORRIDOR DEVELOPMENT CERTIFICATE PROCESS

##### **SECTION A. Trinity River Corridor Interlocal Agreement**

This article recognizes the interlocal agreement effective January 1, 1990, between cities and counties which acknowledge the Trinity River Corridor, herein referred to as the Corridor, is a unique regional resource. Local governments are responsible for the overall health, safety, and welfare of their citizens and must take the lead as stewards of the Corridor. Actions of upstream and downstream communities within the Corridor directly effect each other such that individual local goals for floodplain management, transportation, greenway, waste management, conservation, and development can only be achieved through cooperative management of the Corridor.

##### **SECTION B. Trinity River Corridor Area**

The Corridor is defined as the bed and the banks of the river segments from the dams of Lewisville Lake, Grapevine Lake, Lake Worth, Benbrook Lake, Lake Arlington, and Mountain Creek Lake downstream to the point on the mainstream of the Trinity River near Post Oak Road in southeast Dallas County, and all of the adjacent land area and all watercourses contained within the boundaries of the Corridor floodplain as designated by the latest approved version of the Trinity River Corridor digital map maintained by NCTCOG.

##### **SECTION C. Establishment of Development Permit**

In order to ensure adequate management of the Corridor, a unique certification process has been developed and adopted. To distinguish it from other requirements, the development permit within the Corridor issued by the community will be referenced as a Corridor Development Certificate (CDC). Any public or private development within the Regulatory Zone of the Trinity River Corridor must obtain a Corridor Development Certificate. The Regulatory Zone is the area within the ultimate development 100-year floodplain of the specified reach of the Trinity River as defined by the latest approved version of the digital **Trinity River Corridor Map - CDC Regulatory and Review Zones**. The Review Zone is the area between the Regulatory Zone and the Designated boundaries of the Trinity River as defined by the latest approved version of the digital **Trinity River Corridor Map - CDC Regulatory and Review Zones**. This map is maintained by NCTCOG.

Any public or private development within the Regulatory Zone of the Corridor must obtain a CDC prior to start of any development activity, unless specifically exempted as discussed below. A development activity is defined "any manmade change to improved or unimproved real estate, including, but not limited to, buildings or other structures, mining, dredging, filling, grading, paving, excavation, or drilling operations." To assure consistency with Texas Natural Resources Conservation Commission requirements, development activity also includes "any levee or other improvement".

It is the express purpose of this cooperative certification process to satisfy the requirements of the Federal Emergency Management Agency and the Texas Natural Resources Conservation Commission regarding city floodplain permit actions within the Corridor and to effect close coordination with the U.S. Army Corps of Engineers (COE) and other state or federal agencies that have their own permit processes. The CDC Process does not supersede other Local, State and Federal programs.

**SECTION D. Duties and Responsibilities of the Floodplain Administrator**

Duties and responsibilities of the CDC/Floodplain Administrator shall include, but are not to be limited to, the issuance of CDC permit applications described in Article 9, Section C. Other responsibilities will include a complete and consistent analysis of all CDC applications to include, but not limited to: Project Plans, Hydrologic Data, Hydraulic Data, Elevation - Storage - Discharge Data, COE Jurisdictional Review, and Erosion Control plans. More detailed descriptions of these requirements are outlined in the CDC Manual.

**SECTION E. Common Permit Criteria**

The following common permit criteria describe a consistent design level of flood protection which must be met for all CDC applications. Applications for a CDC permit are required to provide sufficient detailed information to document compliance with the following criteria:

1. Hydraulic Impacts: Project within the Regulatory Zone of the Trinity River Corridor: water surface elevations, storage capacity, velocities, and conveyance.
2. Hydraulic Impacts: Tributary Projects
3. Cumulative Impacts
4. Design Level of Flood Protection: for levees, fills, and structures on fill
5. Borrow Areas
6. Preservation of Adjacent Project Storage.

More detailed descriptions of requirements are outlined in the CDC Manual.

**SECTION F. Exemptions from Corridor Development Certificate (CDC)**

If an applicant, owner, or principal(s) is able to show in writing that a development meets any of the conditions below, it may be exempted by the community from the local CDC permit process. The applicant, owner, or principal(s) is still subject to specific permit requirements as outlined in the community Storm Water and Flood Protection Ordinance and all other Local, State and Federal agency permit requirements. The written exemption will be maintained on file by the community and will be provided to NCTCOG for the permanent records.

**EXEMPTIONS:**

1. Ordinary maintenance and repairs of any operational flood control structures.
2. Outfall structures and associated intake structures where the outfall has been permitted under the Federal NPDES or State TPDES program.
3. Discharge of material for backfill or bedding for utility lines, provided there is no significant change in pre-existing bottom contours and excess material is removed to an upland disposal area.
4. Bank stabilization activities.

5. Property that is (1) completely outside the Regulatory Zone but within the Review Zone; and (2) defined or identified by city ordinance such that the property does not require the Applicant to undergo the CDC process in the Review Zone.
6. Specific Prior Developments - The existing development projects in Section 1.5 DEFINITIONS of this Manual.

**VARIANCES:**

A variance may be sought by any public or private development that cannot meet the established common criteria as detailed in Section 2 of the CDC Manual. A variance shall be any modification of the literal provisions of the CDC Manual when strict enforcement of the CDC process would cause undue hardship, owing to circumstances unique to the individual property on which variance from the process is requested. Variances may be issued for projects deemed to be in the overall regional public interest, as determined by the Planning and Zoning Commission and meet the variance requirements established in Article 4, Section F. An appeal from a determination made by the Planning and Zoning Commission may be made directly to the Court of Appeal.

**SECTION G. Approval Process**

The standard CDC form will be used to record the actions taken and will be sent to NCTCOG for permanent recordkeeping. Approval will be based on compliance with the following steps.

- Step 1. Determination of Applicability by City
- Step 2. Jurisdictional Review by COE
- Step 3. Notice of Intent to Process by City
- Step 4. Parallel COE, FEMA, TWC, and Regional Review
- Step 5. Formal City Action

**SECTION H. Appeals Process**

The Applicant may seek relief from this process. Appellant relief of this permit process shall be sought from the City as an independent permitting authority.

**SECTION I. Technical Updates**

The latest technical hydrologic and hydraulic information concerning the Corridor may be obtained by the CDC/Floodplain Administrator of the respective communities from the North Central Texas Council of Governments and the U.S. Army Corps of Engineers - Fort Worth District.

**SECTION J. CDC Manual**

The most recent CDC Manual shall be adopted as a part of this ordinance. The CDC Manual outlines the detailed requirements of this Article and is adopted in its entirety with the following exceptions:



1. Any provisions in direct contradiction to this ordinance.
2. This ordinance does not adopt provisions of the CDC Manual and CDC mapping related to regulations and their enforcement within the "Review Zone" as defined in these documents.
3. The term of the CDC permit may be extended for multiple three-year periods as deemed appropriate by the City Engineer (see CDC Manual, Page 6, 13).
4. The applicant is not required to officially file the CDC permit in the county records (see CDC Manual, Page 6).
5. The concept of equal conveyance shall not apply in areas where the opposing side of the channel has already been developed to the maximum extent practicable as determined by the City Engineer (see CDC Manual, Page 8).
6. Levee systems shall have a minimum of 4 feet of freeboard above the SPF elevation even if a relief system is provided (see CDC Manual, Page 9).
7. All fills shall have a minimum of 1 foot of freeboard above the ultimate 100-year elevation (see CDC Manual, Page 9).
8. Resource Data and Maintenance and Operation Data are not required (see CDC Manual, Page 11) unless specifically required by this ordinance.
9. Changes in State and Federal regulatory programs will not require a re-evaluation or reapplication (see CDC Manual, Page 13) unless:
  - a) construction on the project has not begun or;
  - b) until the term of the current permit or extension expires.

## ARTICLE 10

### STORM WATER DISCHARGES FROM CONSTRUCTION ACTIVITIES

#### SECTION A. General Requirements

1. All operators of construction sites shall use best management practices to control and reduce the discharge, to the MS4 and to waters of the United States, of sediment, silt, earth, soil and other material associated with the clearing, grading, excavation, and other construction activities to the maximum extent practicable under the circumstances. Such best management practices shall include, but not be limited to, the following measures as appropriate:
  - a. Ensuring that existing vegetation is preserved where feasible and that disturbed portions of the site are stabilized as soon as practicable in portions of the site where construction activities have temporarily or permanently ceased. Stabilization measures may include: temporary seeding, permanent seeding, mulching, geotextiles, sod stabilization, vegetative buffer strips, protection of trees, preservation of mature vegetation, and other appropriate measures. Contractor shall submit, as a part of the Best Management Practices, a plan indicating the phasing of site clearing/grading;
  - b. Use of structural practices to divert flows from exposed soils, store flows, or otherwise limit runoff and the discharge of pollutant from the site to the extent feasible;
  - c. Minimization of the tracking of sediments off-site by vehicles, the generation of dust, and the escape of other windblown waste from the site;
  - d. Prevention of the discharge of building materials, including cement, lime, concrete, and mortar, to the MS4 or waters of the United States;
  - e. Providing general good housekeeping measures to prevent and contain spills of paints, solvents, fuels, septic waste, and other hazardous chemicals and pollutants associated with construction, and to assure proper cleanup and disposal of any such spills in compliance with state, federal, and local requirements;
  - f. Implementation of proper waste disposal and waste management techniques, including covering waste materials and minimizing ground contact with hazardous chemicals and trash;
  - g. Timely maintenance of vegetation, erosion and sediment control measures, and other best management practices in good and effective operating conditions; and
  - h. Installation of structural measures during the construction process to control pollutants in storm water discharges that will occur after construction operations have been completed. Structural measures should be placed on upland soils to the degree attainable. Such installed structural measures may include, but not be limited to, the following: storm water detention structures (including wet ponds); storm water retention structures; flow attenuation by use of open vegetative swales and natural depressions; other velocity dissipation devices; infiltration of runoff on site; and sequential systems which combine several practices. Operators of construction sites are only responsible for the installation and maintenance of storm water management measures prior to final stabilization of the site, and for a period of two years after final acceptance by the City unless the area is disturbed by new owners.
  - i. The owner will escrow 100% of the cost to provide final stabilization to the site. This escrow shall be held for a period of two years from the date of final acceptance. The deposit of an

escrow amount shall not relieve the owner/operator of their responsibility to stabilize the site and remain in conformance with this ordinance and other corresponding regulations. The City shall use the escrow only if the owner/operator fails to stabilize the site in a timely manner.

- j. For common drainage locations that serve an area with 10 or more disturbed acres at one time, a temporary (or permanent) sediment basin providing 3,600 cubic feet of storage per acre drained, or equivalent control measures, shall be provided where attainable until final stabilization of the site. The 3,600 cubic feet of storage area per acre drained does not apply to flows from offsite areas and flows from onsite areas that are either undisturbed or have undergone final stabilization where such flows are diverted around both the disturbed area and the sediment basin. For drainage locations which serve 10 or more disturbed acres at one time and where a temporary sediment basin providing 3,600 cubic feet of storage per acre drained, or equivalent controls is not attainable, smaller sediment basins and/or sediment traps should be used. At a minimum, silt fences, or equivalent sediment controls are required for all sideslopes and downslope boundaries of the construction area.
2. Stabilization measures shall be initiated as soon as practicable in portions of the site where construction activities have temporarily or permanently ceased, but in no case more than 14 days after the construction activity in that portion of the site has temporarily or permanently ceased.
  - a. Where the initiation of stabilization measures by the 14th day after construction activity temporarily or permanently cease is precluded by snow cover, stabilization measures shall be initiated as soon as practicable.
  - b. Where construction activity will resume on a portion of the site within 21 days from when activities ceased, (e.g. the total time period that construction activity is temporarily ceased is less than 21 days) then stabilization measures do not have to be initiated on that portion of site by the 14th day after construction activity temporarily ceased.
3. Qualified personnel (provided by the operator of the construction site) shall inspect disturbed areas of any construction site that have not been finally stabilized, areas used for storage of materials that are exposed to precipitation, structural control measures, and locations where vehicles enter or exit the site, at least once every seven calendar days and within 24 hours of the end of a storm that is 0.5 inches or greater. All erosion and sediment control measures and other identified best management practices shall be observed in order to ensure that they are operating correctly and are effective in preventing significant impacts to receiving waters and the MS4. Based on the results of the inspection, best management practices shall be revised as appropriate, and as soon as is practicable.
4. The City Engineer requires any plans and specifications that are prepared for the construction of site improvements to illustrate and describe the best management practices required by paragraph A.1 above that will be implemented at the construction site. The City may deny approval of any building permit, grading permit, site development plan, or any other City approval necessary to commence or continue construction, or to assume occupancy, on the grounds that the management practices described in the plans or observed upon a site inspection by the City Engineer or his representative are determined not to control and reduce the discharge of sediment, silt, earth, soil, and other materials associated with clearing, grading, excavation, and other construction activities to the maximum extent practicable.
5. Any owner of a site of construction activity, whether or not he/she is an operator, is jointly and severally responsible for compliance with the requirements in this Section A.
6. Any contractor or subcontractor on a site of construction activity, who is not an owner or operator, but who is responsible under his/her contract or subcontract for implementing a best management

practices control measure, is jointly and severally responsible for any willful or negligent failure on his/her part to adequately implement that control measure if such failure causes or contributes to causing the City to violate a water quality standard or any State-issued discharge permit or discharges from its MS4.

#### **SECTION B. Five-Acre Disturbances**

All operators of sites of construction activity, including clearing, grading, and excavation activities, that result in the disturbance of five or more acres of total land area shall comply with the following requirements in addition to those in section A.:

1. Any operator who intends to obtain coverage for storm water discharges from a construction site under the NPDES General Permit for Storm Water Discharges From Construction Sites ("the Construction General Permit") shall submit a signed copy of its Notice of Intent (NOI) to the City Engineer at least two (2) days prior to the commencement of construction activities. If the construction activity is already underway upon the effective date of this Ordinance, the NOI shall be submitted within thirty (30) days. For storm water discharges from construction dates where the operator changes, an NOI shall be submitted at least (2) days prior to when the operator commences work at the site.
2. A Storm Water Pollution Prevention Plan (SWPPP) shall be prepared and implemented in accordance with the requirements of the Construction General Permit or any individual or group NPDES permit issued for storm water discharges from the construction site, and with any additional requirement imposed by or under this Ordinance and any other city ordinance. The SWPPP shall be submitted with the engineering plans for the proposed site improvements.
3. The SWPPP shall be prepared, signed, and sealed by a Registered Professional Engineer or Registered Landscape Architect. The signature and seal of the Registered Professional Engineer or Registered Landscape Architect shall constitute his/her attestation that the SWPPP fully complies with the requirements of the Construction General Permit, or with any applicable individual or group NPDES permit issued for storm water discharges from the construction site, and with any additional requirement imposed by or under this Ordinance. The SWPPP shall contain the name, title, and business address of the Registered Professional Engineer or Registered Landscape Architect signing it, and the date he/she does so.
4. The SWPPP shall be completed prior to the submittal of the NOI to the City Engineer and, for new construction, during the plan review process with the site development plans. The SWPPP shall be updated and modified as appropriate and as required by the Construction General Permit and this Ordinance. (Any update or modification to the SWPPP shall be prepared, signed, and sealed by a Registered Professional Engineer or Registered Landscape Architect, if the original SWPPP was required by paragraph B.3 to have been prepared by a Registered Professional Engineer or Registered Landscape Architect).
5. A copy of any NOI that is required by paragraph B.1 shall be submitted to the City in conjunction with any application for a building permit, grading permit, site development plan approval, and other City approval necessary to commence or continue construction at the site.
6. The City Engineer may require any operator who is required by paragraph B.2 to prepare a SWPPP to submit the SWPPP, and any modifications thereto, to the City Engineer for review. Such submittal and review of the SWPPP may be required by the City Engineer prior to commencement of or during construction activities at the site.

7. Upon the City Engineer's review of the SWPPP and any site inspection that he/she may conduct, the City may deny approval of any building permit, grading permit, site development plan, or any other City approval necessary to commence or continue construction, or to assume occupancy, on the grounds that the SWPPP does not comply with the requirements of the Construction General Permit, any individual or group NPDES permit issued for storm water discharge from the construction site, or any additional requirement imposed by or under this Ordinance. Also, if at any time the City Engineer determines that the SWPPP is not being fully implemented, the City may similarly deny approval of any building permit, grading permit, site development plan or any other City approval necessary to commence or continue construction, or to assume occupancy, at the site.
8. Any significant modification to the SWPPP for a site shall be prepared, signed, and sealed by a Registered Professional Engineer or Registered Landscape Architect as required for the original SWPPP by paragraph B.3.
9. All contractors and subcontractors identified in an SWPPP shall sign a copy of the following certification statement before conducting any professional service identified in the SWPPP.

I certify under penalty of law that I understand the terms and conditions of the National Pollutant Discharge Elimination System (NPDES) permit that authorizes the storm water discharges associated with the industrial activity from the construction site identified as part of this certification, with the Storm Water and Flood Protection Ordinance of the City of Carrollton, and with those provisions of the Storm Water Pollution Prevention Plan (SWPPP) for the construction site for which I am responsible.

The certification must include the name and title of the person providing the signature; the name, address, and telephone number of the contracting firm; the address (or other identifying description) of the site; and the date the certification is made.

10. The SWPPP, with the Registered Professional Engineer's or Registered Landscape Architect's signature and seal affixed, and the certifications of contractors and subcontractors required by paragraph B.9, and with any modifications attached, shall be retained at the construction site from the date of commencement of construction through the date of final stabilization.
11. The operator shall make the SWPPP and any modification thereto available to the City Engineer upon request (as well as to EPA and State inspectors).
12. The City Engineer may notify the operator at any time that the SWPPP does not meet the requirements of the Construction General Permit, any applicable individual or group NPDES permit issued for storm water discharges from the construction site, or any additional requirement imposed by or under this Ordinance. Such notification shall identify those provisions of the permit or Ordinance which are not being met by the SWPPP, and identify which provisions of the SWPPP require modifications in order to meet such requirements. Within seven (7) days of such notification from the City Engineer or as otherwise provided by the City Engineer, the operator shall make the required changes to the SWPPP and shall submit to the City Engineer a written certification that the requested changes have been made.
13. The operator shall amend the SWPPP whenever there is a change in design, construction, operation, or maintenance, which has a significant effect on the potential for the discharge of pollutants to the MS4 or to the waters of the United States, and which has not otherwise been addressed in the SWPPP, or if the SWPPP proves to be ineffective in eliminating or significantly minimizing pollutants, or in otherwise achieving the general objective of controlling pollutants in storm water discharges associated with construction activity. In addition, the SWPPP shall be amended to identify any new contractor and/or subcontractor that will implement a measure in the SWPPP.

14. Qualified personnel (provided by the operator of the construction site) shall inspect disturbed areas of the construction site that have not been finally stabilized, areas used for storage of materials that are exposed to precipitation, structural control measures, and locations where vehicles enter or exit the site, at least once every seven calendar days and within 24 hours of the end of the storm that is 0.5 inches or greater. Disturbed areas and areas used for storage of materials that are exposed to precipitation shall be inspected for evidence of, or the potential for, pollutants entering the drainage system. Erosion and sediment control measures identified in the SWPPP shall be observed to ensure that they are operating correctly. Where discharge locations or points are accessible, they shall be inspected to ascertain whether erosion control measures are effective in preventing significant impacts to receiving waters or the MS4. Locations where vehicles enter or exit the site shall be inspected for evidence of off-site sediment tracking.
15. In case of emergency, City forces will perform corrections and deduct their cost from the escrow account.
16. Based on the results of the inspections required by paragraph B.14, the site description and/or the pollution prevention measures identified in the SWPPP shall be revised as appropriate, but in no case later than seven calendar days following the inspection. Such modifications shall provide for timely implementation of any changes to the SWPPP within seven calendar days following the inspection.
17. A report summarizing the scope of any inspection required by paragraph B.14, and the name(s) and qualifications of personnel making the inspection, the date(s) of the inspection, major observations relating to the implementation of the SWPPP, and actions taken in accordance with paragraph B.15 above shall be made and retained as part of the SWPPP for at least three years from the date that the site is finally stabilized. Such report shall identify any incidence of noncompliance. Where a report does not identify any incidence of noncompliance, the report shall contain a certification that the facility is in compliance with the SWPPP, the facility's NPDES permit, and this Ordinance. The report shall be certified and signed by the person responsible for making the report.
18. The operator shall retain copies of any SWPPP and all reports required by this Ordinance or by the NPDES permit for the site, and records of all data used to complete the NOI, for a period of at least three years from the date that the site is finally stabilized.
19. Where a site has been finally stabilized and all storm water discharges from construction activities that are authorized by this Ordinance and by the NPDES permit for those construction activities are eliminated, or where the operator of all storm water discharges at a facility changes, the operator of the construction site shall submit to the City Engineer a Notice of Termination (NOT) that includes the information required for Notices of Termination by Part VIII of the Construction General Permit.
20. Upon final stabilization of the construction site, the owner (or the duly authorized representative thereof) shall submit written certification to the City Engineer that the site has been finally stabilized. The City may withhold an occupancy or use permit for any premises constructed on the site until such certification of final stabilization has been filed and the City Engineer has determined, following any appropriate inspection, that final stabilization has, in fact, occurred and that any required permanent structural controls have been completed.

TABLE 1

VALUES OF "C" FOR USE IN "RATIONAL METHOD" FORMULA  $Q^* = C_fCIA$

<u>Slope</u>	<u>Land Use from Master Plan</u>	<u>Value of "C" (Runoff Coefficient)</u>
Flat 0% to 1%	Park areas - No developed land	0.20
	Developed Park sites	0.30
	Single Family Residential	0.45
	Duplex	0.50
	Multiple Family	0.55
	Schools**	0.60
	Churches**	0.70
	Local Business	0.65
	Central Business	0.80
	Commercial	0.80
	Industrial	0.75
Moderate 1% to 3.5%	Park areas - No developed land	0.30
	Developed Park sites	0.40
	Single Family Residential	0.55
	Duplex	0.60
	Multiple Family	0.70
	Schools**	0.70
	Churches**	0.75
	Local Business	0.70
	Central Business	0.85
	Commercial	0.85
	Industrial	0.80
Steep 3.5% and over	Park areas - No developed land	0.35
	Developed Park sites	0.45
	Single Family Residential	0.65
	Duplex	0.70
	Multiple Family	0.80
	Schools**	0.80
	Churches**	0.85
	Local Business	0.90
	Central Business	0.90
	Commercial	0.90
	Industrial	0.90

\* Values for  $C_f$  in the rational method shall be 1.0 for the 10 year event and 1.25 for the 100 year storm event.

\*\* Schools and Churches may support alternate "C" values based on specific site plans.

TABLE 2

AVERAGE VELOCITY FOR USE IN DETERMINING TIME OF CONCENTRATION

Description of Water Course	0% to 3% V. in f.p.s.	4% to 7% V. in f.p.s.	8% to 11% V. in f.p.s.	Over 12% V. in f.p.s.
Surface Drainage	5	9	13	15
Channels	Determine V. by Manning's Equation			
Storm Sewers	Determine V. by Manning's Equation			

TABLE 3

MINIMUM SLOPES FOR CONCRETE PIPES

(to produce a velocity of 2.5 f.p.s. or greater)

(n = .013)

Pipe Diameter (inches)	Slope (Feet/100 Feet)	Pipe Diameter (inches)	Slope (Feet/100 Feet)
18	.180	51	.045
21	.150	54	.041
24	.120	60	.036
27	.110	66	.032
30	.090	72	.028
33	.080	78	.025
36	.070	84	.023
39	.062	90	.021
42	.056	96	.019
45	.052	102	.018
48	.048	108	.016



**TABLE 4**

MAXIMUM VELOCITIES IN CONDUITS FLOWING FULL AND CHANNELS

Flow Through:	Maximum Velocity (fps)
Culverts	12.5
Inlet Laterals	10
Storm Sewers	12.5
Earthen Channels	See Table 11
Concrete Channels	12
Shale	6
22Rock 6 - 10*	

\* Depends upon exact type of vegetative cover, soil, or rock for the location in question.

**TABLE 5**

ROUGHNESS COEFFICIENTS FOR CLOSED CONDUITS

Materials of Construction	Recommended Roughness Coefficient "n"
Concrete Pipe Storm Sewer	
Good Alignment, Smooth Joints	.013
Fair Alignment, Ordinary Joints	.015
Poor Alignment, Poor Joints	.017
Concrete Pipe Culverts	.012
Monolithic Concrete Culverts & Conduit	.012
Corrugated Metal Pipe	.024
Corrugated Metal Pipe (Smooth Lined)	.013

TABLE 6

ENTRANCE LOSS COEFFICIENTS

$$\text{Entrance head loss } H_L = K_e \frac{V_1^2}{2g}$$

<u>Type of Structure and Design of Entrance</u>	<u>Coefficient <math>K_e</math></u>
<u>Pipe, Concrete</u>	
Projecting from fill, socket end (groove-end)	0.2
Projecting from fill, square cut end	0.5
Headwall or headwall and wingwalls	
Socket end of pipe (groove-end)	0.2
Square-edge	0.5
Rounded (radius = 1/12D)	0.2
Mitered to conform to fill slope	0.7
End-section conforming to fill slope	0.5
Beveled edges, 33.7 or 45 bevels	0.2
Side- or slope-tapered inlet	0.2
<u>Pipe, or Pipe-Arch, Corrugated Metal</u>	
Projecting from fill (no headwall)	0.9
Headwall or headwall and wingwalls square-edge	0.5
Mitered to conform to fill slope, paved or unpaved slope	0.7
End-section conforming to fill slope	0.5
Beveled edges, 33.7 or 45 bevels	0.2
Side- or slope-tapered inlet	0.2
<u>Box, Reinforced Concrete</u>	
Headwall parallel to embankment (no wingwalls)	
Square-edged on 3 edges	0.5
Rounded on 3 edges to radius of 1/12 barrel dimension or beveled edges on 3 sides	0.2
Wingwalls at 30 to 75 to barrel	
Square-edged at crown	0.4
Crown edge rounded to radius of 1/12 barrel dimension dimension, or beveled top edge	0.2
Wingwall at 10 to 25 to barrel	
Square-edged at crown	0.5
Wingwall parallel (extension of sides)	
Square-edged at crown	0.7
Side- or slope-tapered inlet	0.2

TABLE 7

VELOCITY HEAD LOSS COEFFICIENTS FOR CLOSED CONDUITS



MANHOLE AT CHANGE IN PIPE DIRECTION		
DESCRIPTION	ANGLE	HEAD LOSS COEFFICIENT $K_j$
 <p><math>D1 = D2</math></p>	90°	0.55
	60°	0.48
	45°	0.42
	30°	0.30
	0°	0.05
	BENDS IN PIPES	
DESCRIPTION	ANGLE	HEAD LOSS COEFFICIENT $K_j$
	90°	0.50
	60°	0.43
	45°	0.37
	30°	0.25
JUNCTION		
DESCRIPTION	ANGLE	HEAD LOSS COEFFICIENT $K_j$
	0°	1.00
	22 1/2°	0.75
	45°	0.50
	60°	0.35
	90°	0.25

TABLE 8

ROUGHNESS COEFFICIENTS FOR OPEN CHANNELS FLOW AREAS

<u>Channel Description</u>	<u>Roughness Coefficient</u>		
	<u>Minimum</u>	<u>Normal</u>	<u>Maximum</u>
MINOR NATURAL STREAMS (Top Width at Flood Stage Less Than 100 Feet)			
Moderately Well-Defined Channel			
Grass and Weeds, Little Brush	0.025	0.030	0.033
Dense Weeds, Little Brush	0.030	0.035	0.040
Weeds, Light Brush on Banks	0.030	0.035	0.040
Weeds, Heavy Brush on Banks	0.035	0.050	0.060
Weeds, Dense Willows on Banks	0.040	0.060	0.080
Irregular Channel with Pools and Meanders			
Grass and Weeds, Little Brush	0.030	0.036	0.042
Dense Weeds, Little Brush	0.036	0.042	0.048
Weeds, Light Brush on Banks	0.036	0.042	0.048
Weeds, Heavy Brush on Banks	0.042	0.060	0.072
Weeds, Dense Willows on Banks	0.048	0.072	0.096
Floodplain, Pasture			
Short Grass, No Brush	0.020	0.030	0.035
Tall Grass, No Brush	0.025	0.035	0.050
Floodplain, Cultivated			
No Crops	0.025	0.030	0.035
Mature Crops	0.030	0.040	0.050
Floodplain, Uncleared			
Heavy Weeds, Light Brush	0.035	0.050	0.070
Medium to Dense Brush	0.070	0.100	0.160
Trees with Flood Stage Below Branches	0.080	0.100	0.120
MAJOR NATURAL STREAMS (Top Width at Flood Stage Greater Than 100 Feet)			
The roughness coefficient is less than that for minor streams of similar description because banks offer less effective resistance.			
Moderately Well Defined Channel	0.025	---	0.060
Irregular Channel	0.035	---	0.100

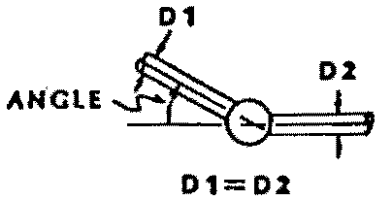
TABLE 8, continued

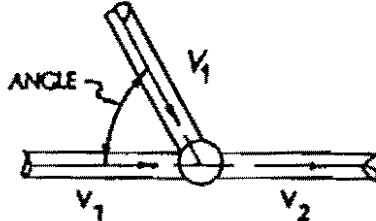
<u>Channel Description</u>	<u>Roughness Coefficient</u>		
	<u>Minimum</u>	<u>Normal</u>	<u>Maximum</u>
<b>MANMADE VEGETATED CHANNELS</b>			
Mowed Grass, Clay Soil	0.025	0.030	0.035
Mowed Grass, Sandy Soil, or Easily Erodible Soils	0.025	0.030	0.035
<b>MANMADE NON-VEGETATED CHANNELS</b>			
Clean Gravel Section	0.022	0.025	0.030
Shale	0.025	0.030	0.035
Smooth Rock	0.025	0.030	0.035
<b>LINED CHANNELS</b>			
Smooth Finished Concrete	0.013	0.015	0.020
Riprap (Larger Pieces)	0.030	0.040	0.050

**TABLE 9.A**

**TEMPORARY VEGETATION**

Temporary Vegetation - The following plants are commonly used for temporary cover in Texas. For optimum planting dates and adaptations for a specific soil or site, contact your local field office of the USDA, Soil Conservation Service.

<u>Species</u>	<u>Planting Rate/Acre</u> <sup>1</sup>	<u>Planting Date</u> <sup>2</sup>	<u>Source</u> <sup>3</sup>
Cane, Redtop	30#/S	8/15-9/30	C
Millet, German	40#/s	4/1-5/15	C
Oats	3 bu/S	8/15-9/30	C
Panicum, Texas	25#/S	3/15-5/15	C
Prosomillet	40#/S	4/1-5/15	C
Rye, Elbon	1-1/2 bu/S	8/15-9/30	C
Ryegrass, Annual	30#/S	8/15-9/30	C
Sprangletop, Green	3,4#PLS/S	2/1-5/15	C
Sudangrass	40#/S	4/1-5/15	C

<sup>1</sup> Planting Rate/Acre: S - # Commercial Seed/AC, bu - bushels/AC, #PLS - Pure Live Seed/AC

<sup>2</sup> Planting Date: This represents a statewide spread in planting dates. Refer to local guides for specific dates.

<sup>3</sup> Source: C - Commercial

TABLE 9.B

PERMANENT VEGETATION - LOW AREAS

Permanent Vegetation - Because of wide variations in growing conditions within a planned area, permanent vegetation has been selected for the following conditions. For optimum planting dates and adaptations for a specific soil or site, contact your local field office of the USDA, Soil Conservation Service.

Note: Low areas are subject to ephemeral and intermittent flows.

<u>Species</u>	<u>Moisture Tolerance</u> <sup>1</sup>	<u>Planting Rate/Materials</u> <sup>2</sup>	<u>Planting Date</u> <sup>3</sup>	<u>Source</u> <sup>4</sup>
Bermudagrass, Coastal or Selection Common	3A/2 A/2	50 cu.ft/Ac/Sp 4.6#/Ac/S	12/1-5/30 3/1-5/30	C C
Buffalograss	A/3	32#/Ac/S	1/1-4/30	C or PMC
Bushy Beard Grass	C/3	---	Spring	-
Cordgrass, Prairie	B/2	1/sq.ft/R	1/1-5/30	L
Eastern Gammagrass	C/3	---	Spring	-
Knotgrass	A/2	1/sq.ft/R&St	2/1-5/30	L
Marshmillet	B/1	1/sq.ft/R	4/1-5/30	L
Reedgrass, Common	A/2	1/sq.ft/R	2/1-5/30	L or PMC
Vine-mesquite	A/2	1/sq.ft/St	2/1-1/30	L

<sup>1</sup> Moisture Tolerance:      Total Submergence                      Soil Saturation  
    A - 20 days or more                      1 - Require a saturated soil  
    B - 10 - 20 days                              2 - Will tolerate prolonged saturation and  
    C - Less than 10 days                              frequent drought.  
       3 - Will not tolerate a constantly saturated  
       soil.

<sup>2</sup> Planting: Rate - #PLS/AC, Plant Parts/sq.ft.  
 Materials - S - Seed, R - Rhizomes, Sp - Sprigs, St - Stolons

<sup>3</sup> Planting Date: This represents a statewide spread in planting dates. Refer to local guides for specific dates.

<sup>4</sup> Source: C - Commercial, L - Locally Collected, PMC - Plant Material Center (as available)

TABLE 9.C

PERMANENT VEGETATION - SIDE SLOPES

<u>Species</u>	<u>Soils</u> <sup>2</sup>	<u>Planting Rate/Materials</u> <sup>3</sup>	<u>Planting Date</u> <sup>4</sup>	<u>Source</u> <sup>5</sup>
<u>Grasses</u>				
Bermudagrass,	All	4.6#/Ac/S	3/1-5/30	C
Common Selection 3				
or Coastal	All	50 cu.ft/Ac/Sp	12/1-5/30	C
Bluestem,				
K.R.*	M-F	4#/Ac/S	12/1-5/30	C
Old World*	M-F	2.4#/Ac/S	2/1-5/30	PMC
Buffalograss*	M-F	32#/Ac/S	1/1-5/15	C or PMC
Dallisgrass	M-F	7#/Ac/S	2/1-5/30	C
Knotgrass <sup>1</sup>	All	1/sq.ft/R&St	2/1-5/30	L
Vine-mesquite	All	1/sq.ft/St	2/1-4/30	L
Wildrye	All	25#/Ac/S	9/1-10/1	L
<u>Forbs:</u>				
Bushsunflower*	All	10#/Ac/S	4/1-5/20	L or PMC
Englemandaisy* <sup>1</sup>	All	30#/Ac/S	9/1-2/30	L or PMC
<u>Legumes:</u>				
Trailing wildbean*	C-M	25#/Ac/S	2/15-5/15	L or PMC
Vetch*	All	20#/Ac/S	9/1-10/1	C

\*Mixtures only: Reduce rates according to percentage of mixture desired.

<sup>1</sup> Lower portion of slope only, frequently inundated.

<sup>2</sup> Soils: C - Coarse, M - Medium, F - Fine

<sup>3</sup> Planting: Rate - #PLS/AC, Plant Parts/sq.ft.  
Materials - S - Seed, R - Rhizomes, Sp - Sprigs, St - Stolons

<sup>4</sup> Planting Date: This represents a statewide spread in planting dates. Refer to local guides for specific dates.

<sup>5</sup> Source: C - Commercial, L - Locally Collected, PMC - Plant Material Center (as available)



TABLE 9.D

PERMANENT VEGETATIONBERMS, SPOIL BANKS, AND SIMILAR AREAS

<u>Species</u>	<u>Soils</u> <sup>1</sup>	<u>Planting Rate/Materials</u> <sup>2</sup>	<u>Planting Date</u> <sup>3</sup>	<u>Source</u> <sup>4</sup>
<u>Grasses</u>				
Bermudagrass, Common Selection 3 or Coastal	All	4.6#/Ac/S	3/1-5/30	C
	All	50 cu.ft/Sp	12/1-5/30	C
Bluestem, Caucasian*	M-F	4#/Ac/S	12/1-5/30	C
K.R.*	M-F	4#/Ac/S	12/1-5/30	C
Little*	All	6.8#/Ac/S	2/1-5/15	C
Buffalograss*	All	6#/Ac/S	2/1-5/15	C
Fescue	M-F	20#/Ac/S	9/1-10/30	C
Hardinggrass "Wintergreen"	M-F	6#/Ac/S	9/1-10/30	C
Indiangrass*	All	9#/Ac/S	2/1-5/30	C
Kleingrass, "Selection 75**"	M-F	4#/Ac/S	1/1-5/30	C
Wildrye*	All	30#/Ac/S	9/1-10/1	L
Wintergrass, Texas*	M-F	30#/Ac/S	9/1-10/30	C
<u>Forbs:</u>				
Bushsunflower*	All	10#/Ac/S	4/1-5/30	L or PMC
Englemandaisy*	All	30#/Ac/S	9/1-2/30	L or PMC
Partridgepea*	C-M	10#/Ac/S	2/15-5/15	C or PMC
Sunflower, Maximilian*	All	16#/Ac/S	4/1-5/30	L or PMC

TABLE 9.D, continued

<u>Species</u>	<u>Soils</u> <sup>1</sup>	<u>Planting Rate/Materials</u> <sup>2</sup>	<u>Planting Date</u> <sup>3</sup>	<u>Source</u> <sup>4</sup>
<u>Legumes:</u>				
Clover,				
Crimson*	M	20#/Ac/S	9/1-10/30	C
White*	M-F	3#/Ac/S		C
Trailing wildbean*	C-M	10#/Ac/S	2/15-5/15	PMC
Vetch*	All	20#/Ac/S	9/1-10/1	C

\*Mixtures only: Reduce rates according to percentage of mixture desired.

<sup>1</sup> Soils: C - Coarse, M - Medium, F - Fine

<sup>2</sup> Planting: Rate - #PLS/AC, Plant Parts/sq.ft.  
Materials - S - Seed, R - Rhizomes, Sp - Sprigs, St - Stolons

<sup>3</sup> Planting Date: This represents a statewide spread in planting dates. Refer to local guides for specific dates.

<sup>4</sup> Source: C - Commercial, L - Locally Collected, PMC - Plant Material Center (as available)

TABLE 10

SYNOPSIS OF REQUIREMENTS  
TO PROTECT STRUCTURES FROM FLOODING

	Is a Development Permit Req'd?	Is a Floodplain Alteration Permit Required?	Is Lowest Floor Req'd To Be 2 Feet Above Design Flood Elev.?	Is Floodproofing Allowed as an Alternative to Lowest Floor Requirement?
<b>RESIDENTIAL</b>				
New Structure	Yes	Yes, if new structures are being placed in a proposed floodplain reclamation area.	Yes	No
Substantial improvement (i.e., value of renovation of existing structure is greater than 50% of the structure).	Yes	Yes, if structure is subject to flooding.	Yes, of improvement	No
Renovation valued at less than 50% of the structure's value, with no expansion of outside dimensions.	No	No	No	Floodproofing is allowed, but not required.
Renovation valued at less than 50% of the structure's value, but including expansion of outside dimensions.	Yes	Yes, if structure is subject to flooding.	No	Floodproofing is allowed, but not required.

TABLE 10, continued

	Is a Development Permit Req'd?	Is a Floodplain Alteration Permit Required?	Is Lowest Floor Req'd To Be 2 Feet Above Design Flood Elev.?	Is Floodproofing Allowed as an Alternative to Lowest Floor Requirement?
<b>NON-RESIDENTIAL</b>				
New Structure	Yes	Yes, if new structures are being placed in a proposed floodplain reclamation area.	Yes	No
Substantial improvement (i.e., value of renovation of existing structure is greater than 50% of the structure).	Yes	Yes, if structure is subject to flooding.	Yes, of improvement	Yes
Renovation valued at less than 50% of the structure's value, with no expansion of outside dimensions.	No	No	No	Floodproofing is allowed, but not required.
Renovation valued at less than 50% of the structure's value, but including expansion of outside dimensions.	Yes	Yes, if structure is subject to flooding.	No	Floodproofing is allowed, but not required.

TABLE 10, continued

	Is a Development Permit Req'd?	Is a Floodplain Alteration Permit Required?	Is Lowest Floor Req'd To Be 2 Feet Above Design Flood Elev.?	Is Floodproofing Allowed as an Alternative to Lowest Floor Requirement?
<b>MANUFACTURED HOMES</b>				
New home placed at any pad site	Yes	Yes, if new structures are being placed in a proposed floodplain reclamation area.	Yes	No
Expansion of an existing home park	Yes	Yes, if the park is in a floodplain area.	Yes	No
New home park	Yes	Yes, if the new park is being located in a proposed floodplain area.	Yes	No
Substantial improvements to an existing manufactured home	Yes	Yes, if the pad site for the home is in a flood hazard area and the pad is being raised or expanded.	Yes	No
Renovation valued at less than 50% of the manufactured home's value, with no expansion of the home's or pad's outside dimensions.	No	No	No	No
Renovation valued at less than 50% of the manufactured home's value, but including expansion of its outside dimensions.	Yes	Yes, if structure is subject to flooding.	No	No

TABLE 10, continued

	Is a Development Permit Req'd?	Is a Floodplain Alteration Permit Required?	Is Lowest Floor Req'd To Be 2 Feet Above Design Flood Elev.?	Is Floodproofing Allowed as an Alternative to Lowest Floor Requirement?
<b>RECREATIONAL VEHICLES</b>				
Recreational Vehicle which is: 1. on a site less than 180 consecutive days, 2. fully licensed and ready for highway use, 3. has quick disconnect utilities and devices, and 4. has no permanently attached additions.	No	No	No	No
Vehicle at any pad site which does not meet all recreational requirements	Yes	Yes, if vehicle is being placed in a proposed floodplain reclamation area.	Yes	No
Vehicles which do not meet all recreational requirements at an expansion of an existing home park	Yes	Yes, if the park is in a floodplain area.	Yes	No
New home park for vehicles which do not meet all recreational requirements	Yes	Yes, if the new park is being located in a proposed floodplain area.	Yes	No

TABLE 11

MAXIMUM PERMISSIBLE VELOCITIES FOR CHANNELS LINED WITH GRASS

COVER	SLOPE RANGE, * %	PERMISSIBLE VELOCITY, FPS
		Easily Eroded Soils
Bermuda Grass	0-5	6
	5-10	5
	>10	4
Buffalo grass, Kentucky bluegrass smooth brome, blue grama	0-5	5
	5-10	4
	>10	3
Grass mixture	0-5	4
	5-10	3
	Do not use on slopes steeper than 10%	
Lespedeza sericea, weeping love grass, grass, ischaemum (yellow blue-stem), kudzu, alfalfa, crabgrass	0-5	2.5
	Do not use on slopes steeper than 5% except for side slopes in a combination channel.	
Annuals - used on mild slopes or as temporary protection until permanent covers are established, common lespedeza, Sudan grass	0-5	2.5
	Use on slopes steeper than 5% is not recommended.	

Remarks: The values apply to average, uniform stands of each type of cover. Use velocities exceeding 5 fps only where good covers and proper maintenance can be obtained. Based on past experience, all soils within the City of Carrollton have been found to be easily eroded soils.

\* Longitudinal bed slope of the channel bottom.

CITY OF CARROLLTON RAINFALL INTENSITY VALUES

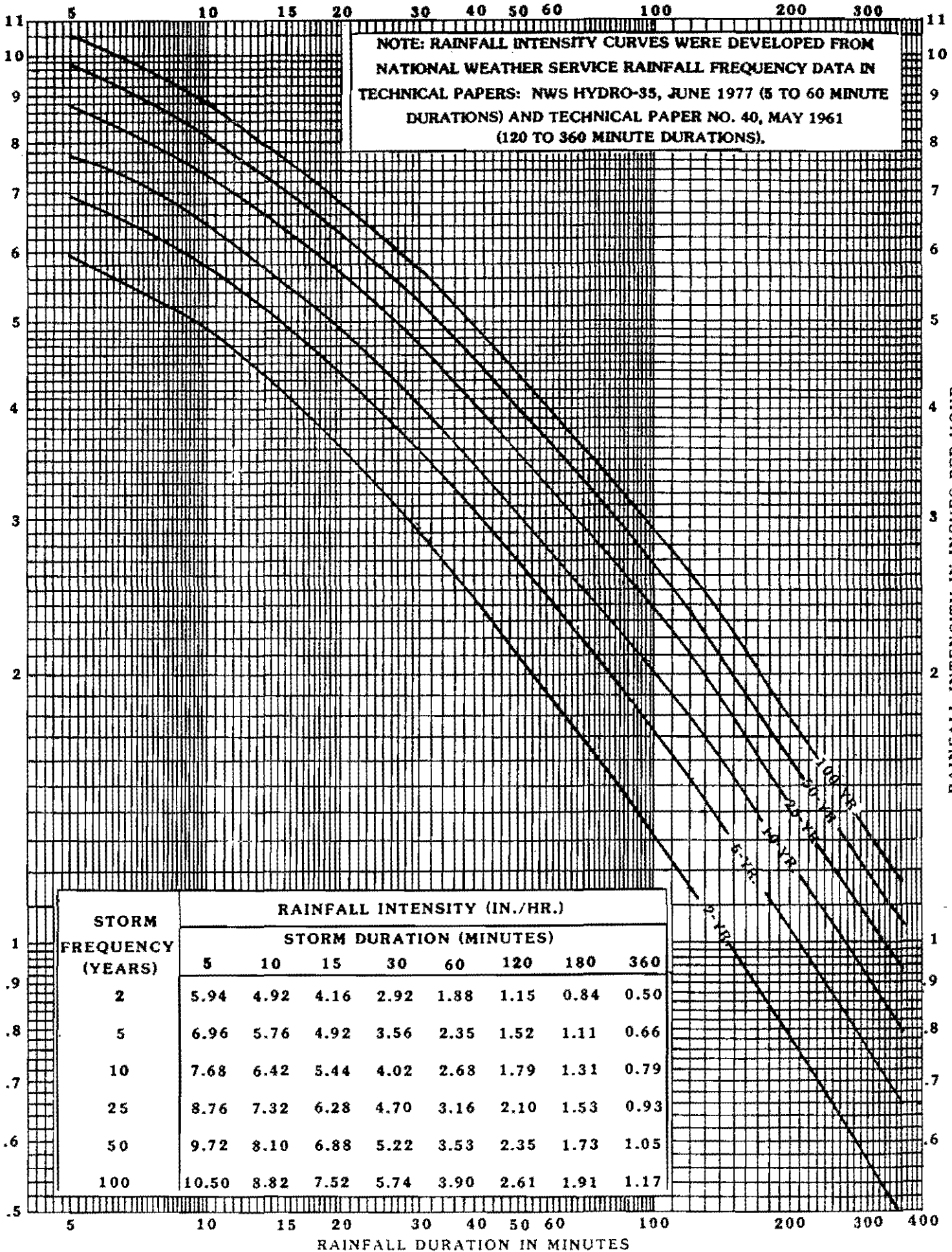



# CAPACITY OF TRIANGULAR GUTTERS

FIGURE 2

## EXAMPLE

**KNOWN :**

- MAJOR THOROUGHFARE, TYPE M6D
- PAVEMENT WIDTH : 33'
- GUTTER SLOPE : 2.0%
- PAVEMENT CROSS SLOPE :  $3/8''/1'$
- DEPTH OF GUTTER FLOW : .5'

**SOLUTION:**

- ENTER GRAPH AT .5'
- INTERSECT CROSS SLOPE :  $3/8''/1'$
- INTERSECT GUTTER SLOPE : 2.0%
- READ GUTTER CAPACITY : 23.5 c.f.s.

**FIND:**

GUTTER CAPACITY

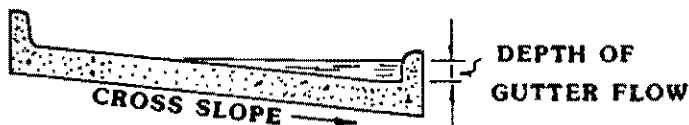
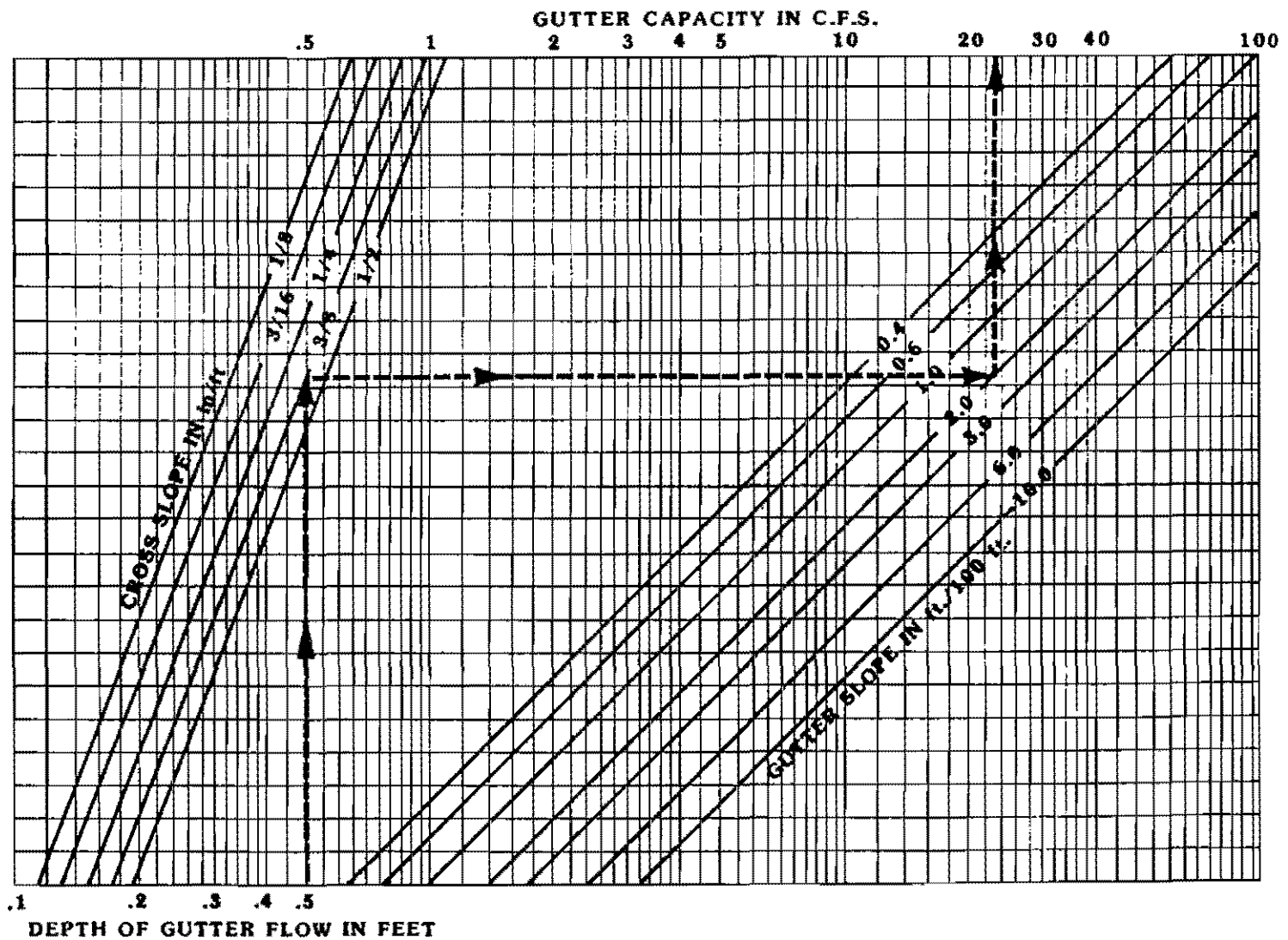

**STREET WIDTH**

30'      36'

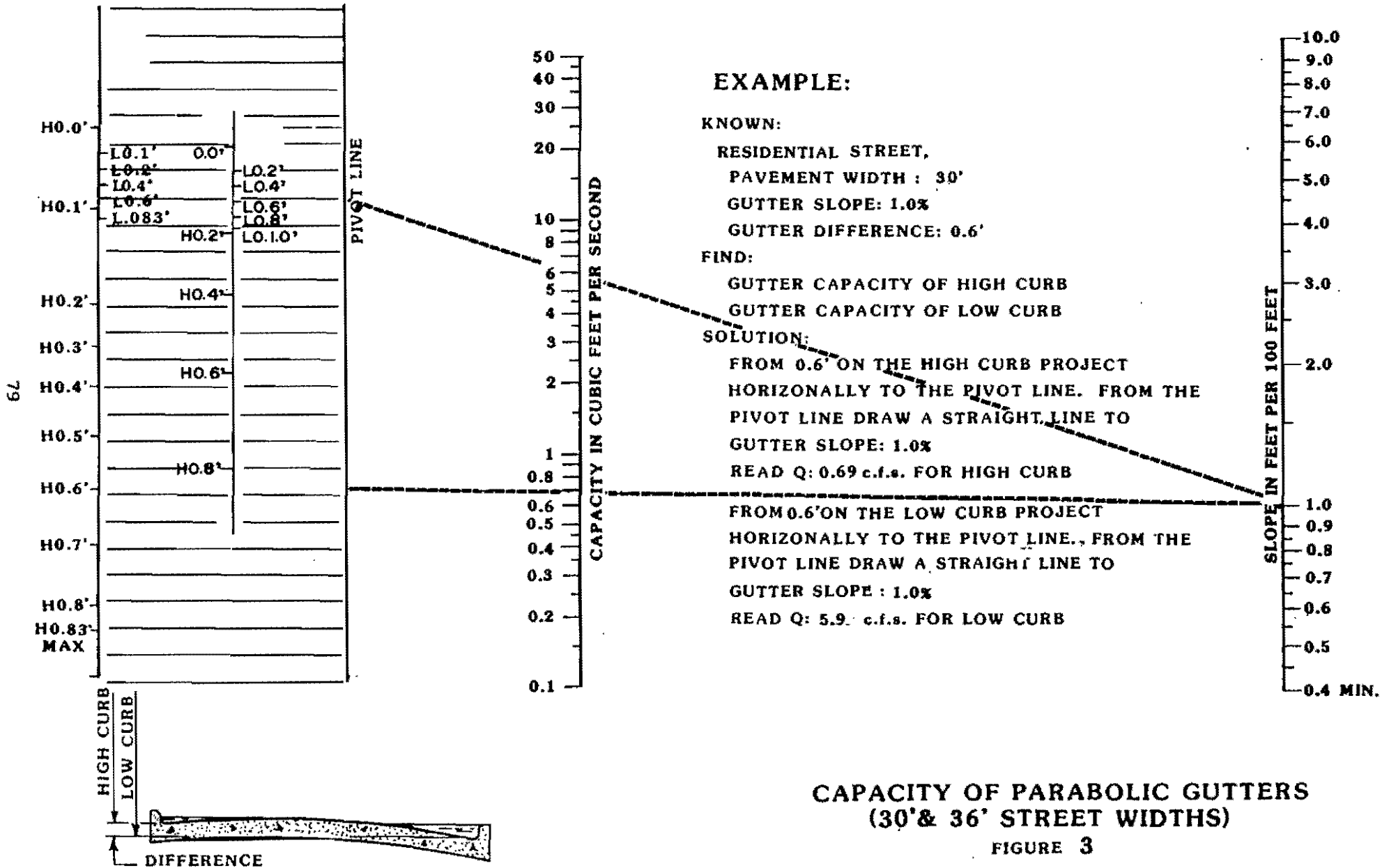

**CAPACITY OF PARABOLIC GUTTERS  
 (30' & 36' STREET WIDTHS)**

**FIGURE 3**

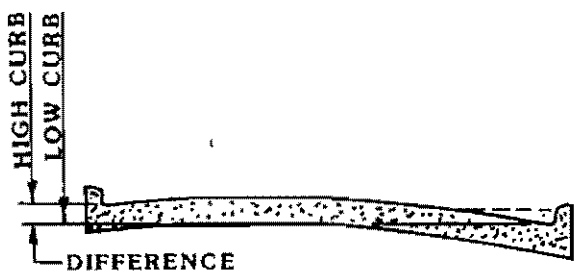
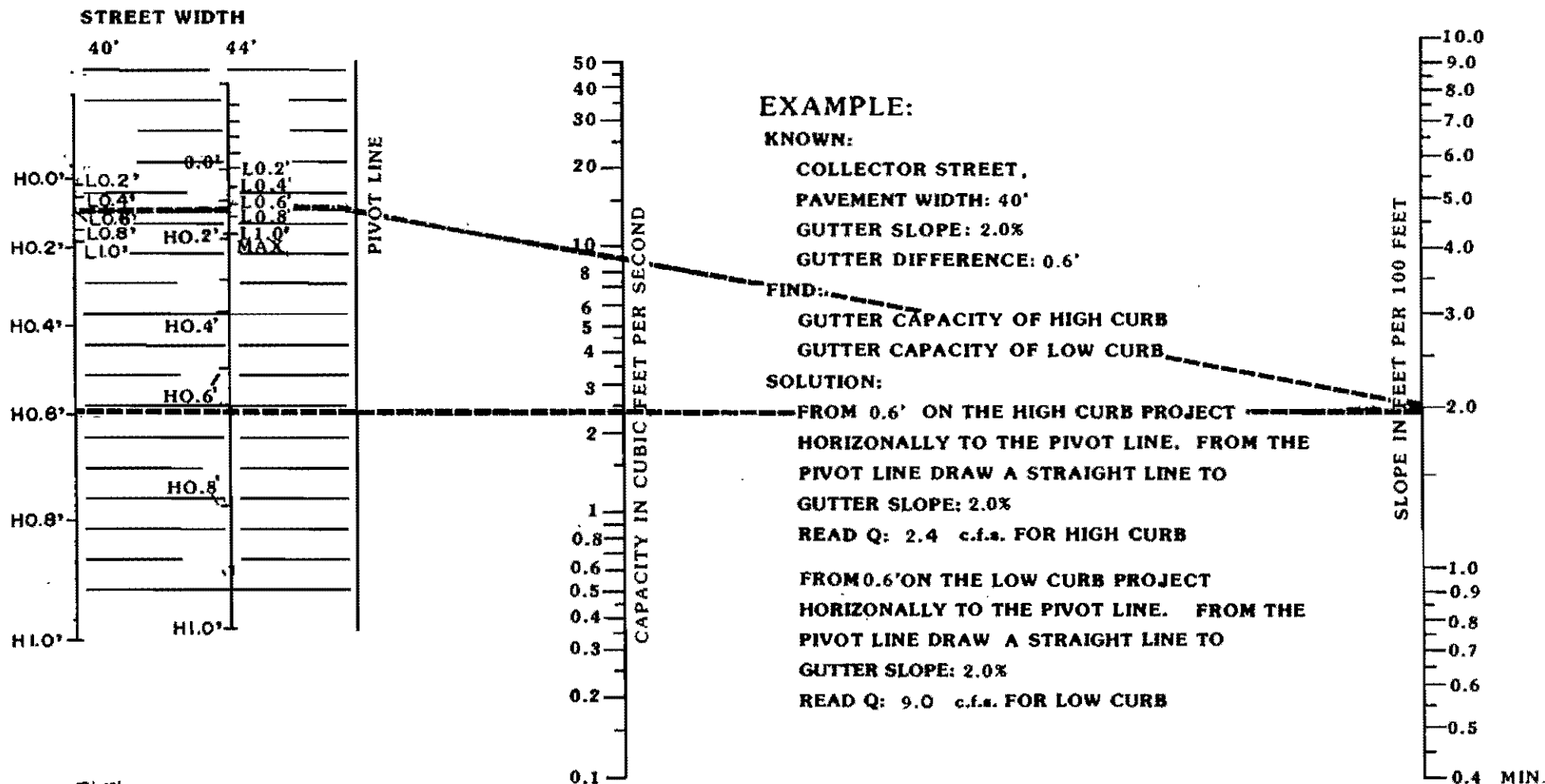

**CAPACITY OF PARABOLIC GUTTERS  
(40' & 44' STREET WIDTHS)**

**FIGURE 4**

# CAPACITY OF ALLEY SECTIONS

$n:0.0175$

FIGURE 5

## EXAMPLE :

KNOWN:

ALLEY WIDTH: 12'

ALLEY DEPRESSION: 5"

GUTTER SLOPE: 4.0%

FIND:

GUTTER FLOW (Q)

SOLUTION:

CONNECT THE 12' ALLEY SECTION WITH

SLOPE: 4.0%

READ Q: 14.9 c.f.s.

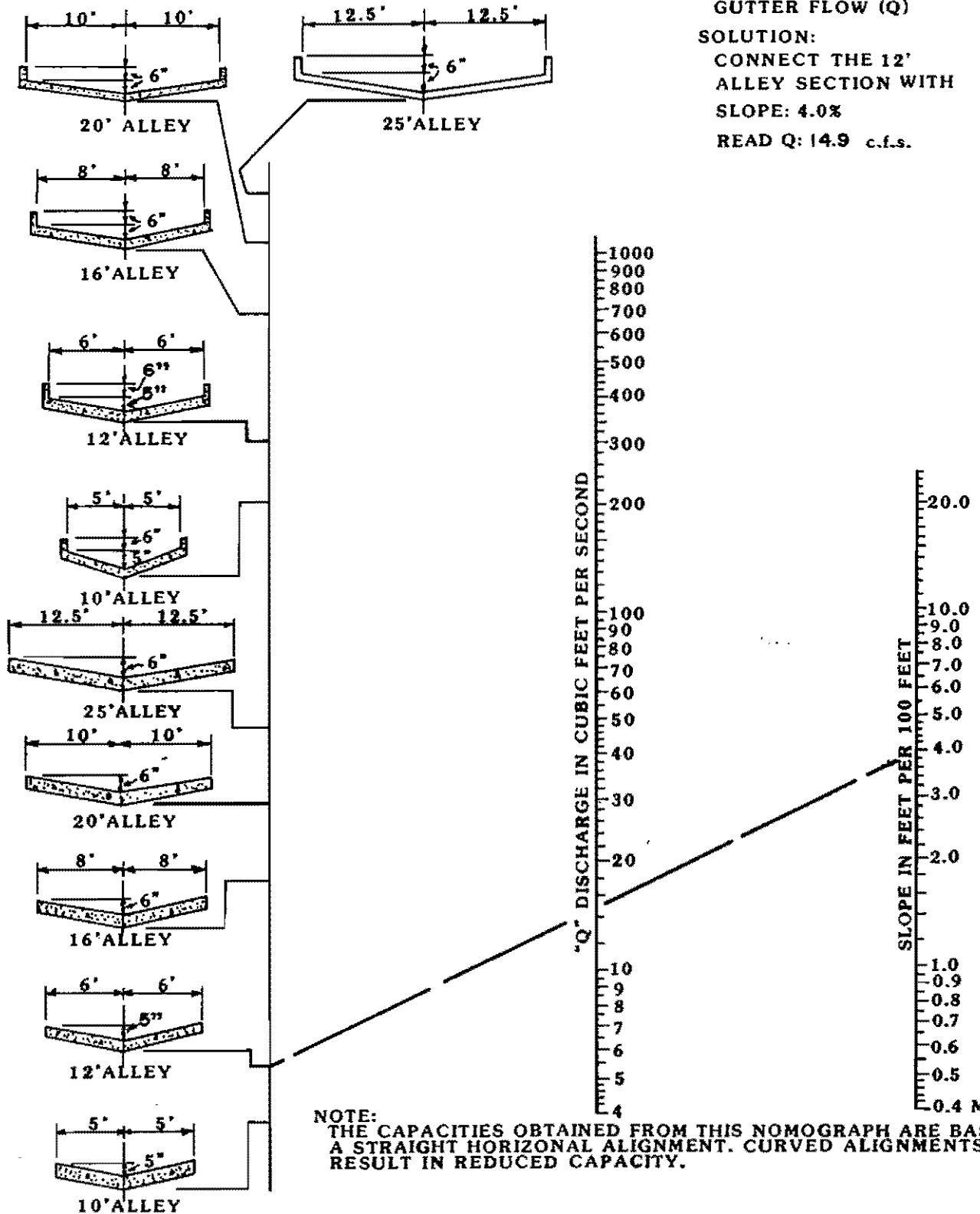

NOTE: THE CAPACITIES OBTAINED FROM THIS NOMOGRAPH ARE BASED ON A STRAIGHT HORIZONTAL ALIGNMENT. CURVED ALIGNMENTS MAY RESULT IN REDUCED CAPACITY.

FIGURE 6

STORM DRAIN INLETS







INLET DESCRIPTION	AVAIL. INLET SIZES	WHERE USED	DESIGN CURVES
 <p>STANDARD CURB OPENING INLET ON GRADE</p>	<p>8' 10' 12' 14'</p>	<p>Residential Street, Collector Street - Types C2UA and C2UB; Alley</p>	<p>Figures 7 Through 11</p>
 <p>STANDARD CURB OPENING INLET AT LOW POINT</p>	<p>8' 10' 12' 14'</p>	<p>Residential Street, Collector Street - Types C2UA and C2UB; Alley</p>	<p>Figure 12</p>
 <p>RECESSED CURB OPENING INLET ON GRADE</p>	<p>8' 10' 12' 14'</p>	<p>Collector Street, Type C4U Major Streets - Types M4U, M4D, M6D, Principal Streets (P6D)</p>	<p>Figures 7 Through 11</p>
 <p>RECESSED CURB OPENING INLET AT LOW POINT</p>	<p>8' 10' 12' 14'</p>	<p>Collector Street, Type C4U Major Streets - Types M4U, M4D, M6D, Principal Streets (P6D)</p>	<p>Figure 12</p>

FIGURE 6 CONTINUED

INLET DESCRIPTION	AVAIL. INLET SIZES	WHERE USED	DESIGN CURVES
 <p>COMBINATION INLET ON GRADE</p>	8'	Combination Inlets to be Used Where Space Behind Curb Prohibits Other Inlet Types	Figures 13  Through 15
 <p>COMBINATION INLET AT LOW POINT Must Be Approved By The City Engineer</p>	8'	Combination Inlets to be Used Where Space Behind Curb Prohibits Other Inlet Types	Figure 16
 <p>GRATE INLETS Must Be Approved By The City Engineer</p>	2 GRATE 3 GRATE 4 GRATE 6 GRATE	Grate Inlets to be Used Where Space Restrictions Prohibit Other Inlet Types or At Locations with No Curb.	Figures 17 THROUGH 20
 <p>DROP INLET</p>	2' x 2' 3' x 3' 4' x 4'	Open Channels	Figure 21

RECESSED AND STANDARD  
CURB OPENING INLET  
CAPACITY CURVES

FIGURE 7

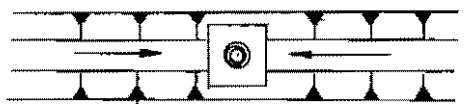
ON  
GRADE

EXAMPLE

KNOWN:

PAVEMENT WIDTH : 30'  
GUTTER SLOPE: 2.0 %  
5" PARABOLIC CROWN  
GUTTER FLOW: 5.2 c.f.s.

FIND:

LENGTH OF INLET REQUIRED

SOLUTION:

ENTER GRAPH AT 5.2 c.f.s.  
INTERSECT SLOPE: 2.0 %  
READ  $L_1$ : 8.7'

DECISION:

1. USE 10' INLET  
NO FLOW REMAINS IN GUTTER
2. USE 8' INLET  
INTERCEPT ONLY PART OF FLOW  
USE 8' INLET  
ENTER GRAPH AT  $L_1$ : 8'  
INTERSECT SLOPE: 2.0 %  
READ Q: 4.6 c.f.s.  
REMAINING GUTTER FLOW: 5.2 c.f.s. - 4.6 c.f.s. = .6 c.f.s

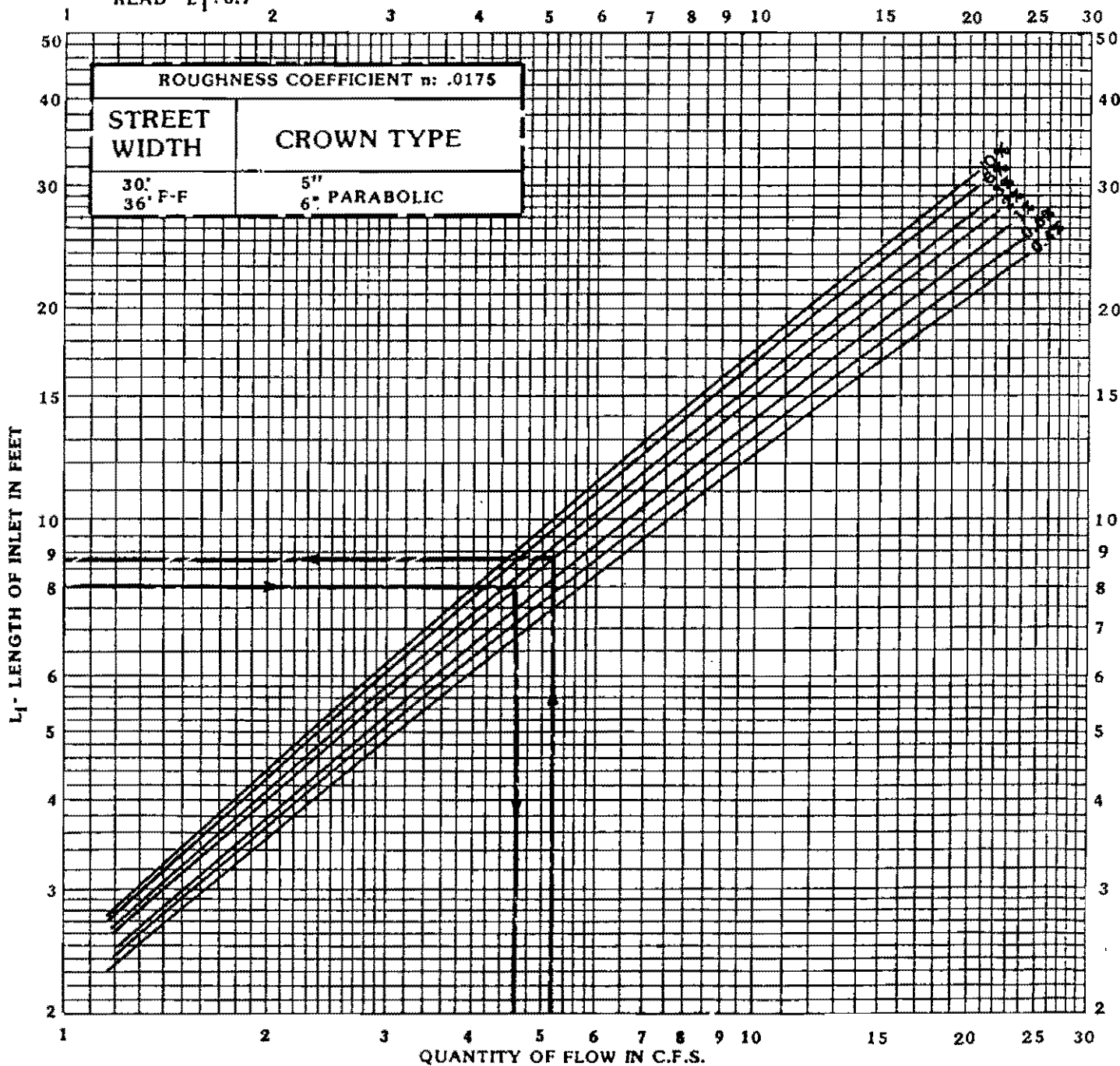

# RECESSED AND STANDARD CURB OPENING INLET CAPACITY CURVES ON GRADE

FIGURE 8

**EXAMPLE**

**KNOWN:**

PAVEMENT WIDTH : 36'  
GUTTER SLOPE: 3.0%  
1/2"/ft CROSS SLOPE  
GUTTER FLOW: 5.2 c.f.s.

**FIND:**

LENGTH OF INLET REQUIRED

**SOLUTION:**

ENTER GRAPH AT 5.2 c.f.s.  
INTERSECT SLOPE: 3.0%  
READ  $L_1$ : 8.8'

**DECISION:**

1. USE 10' INLET  
NO FLOW REMAINS IN GUTTER
2. USE 8' INLET  
INTERCEPT ONLY PART OF FLOW  
USE 8' INLET  
ENTER GRAPH AT  $L_1$ : 8'  
INTERSECT SLOPE: 3.0%  
READ Q: 4.6 c.f.s.  
REMAINING GUTTER FLOW: 5.2 c.f.s. - 4.6 c.f.s.: 0.6 c.f.

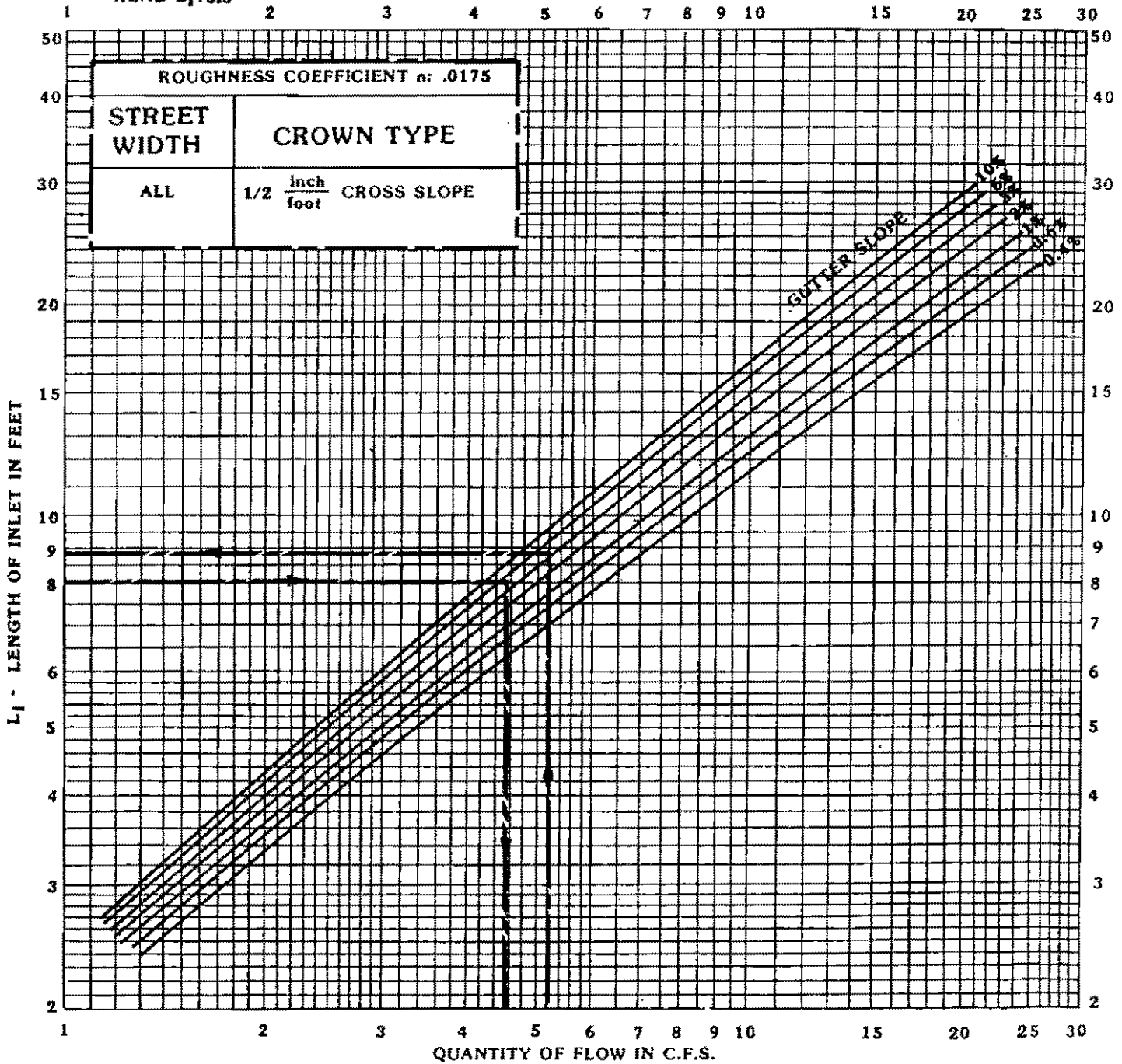



# RECESSED AND STANDARD CURB OPENING INLET CAPACITY CURVES ON GRADE

FIGURE 9

## EXAMPLE

**KNOWN:**

PAVEMENT WIDTH : 30'  
 GUTTER SLOPE: 3.0%  
 PAVEMENT CROSS SLOPE: 1/4"/1'  
 GUTTER FLOW: 4.8 c.f.s.

**FIND:**

LENGTH OF INLET REQUIRED

**SOLUTION:**

ENTER GRAPH AT 4.8 c.f.s.  
 INTERSECT SLOPE: 3.0%  
 READ  $L_1$  : 9.5'

**DECISION:**

1. USE 10' INLET  
NO FLOW REMAINS IN GUTTER
2. USE 8' INLET  
INTERCEPT ONLY PART OF FLOW  
USE 8' INLET  
ENTER GRAPH AT  $L_1$  : 8'  
INTERSECT SLOPE: 3.0%  
READ Q: 3.9 c.f.s.  
REMAINING GUTTER FLOW: 4.8 c.f.s.-3.9 c.f.s.:0.9 c.f.

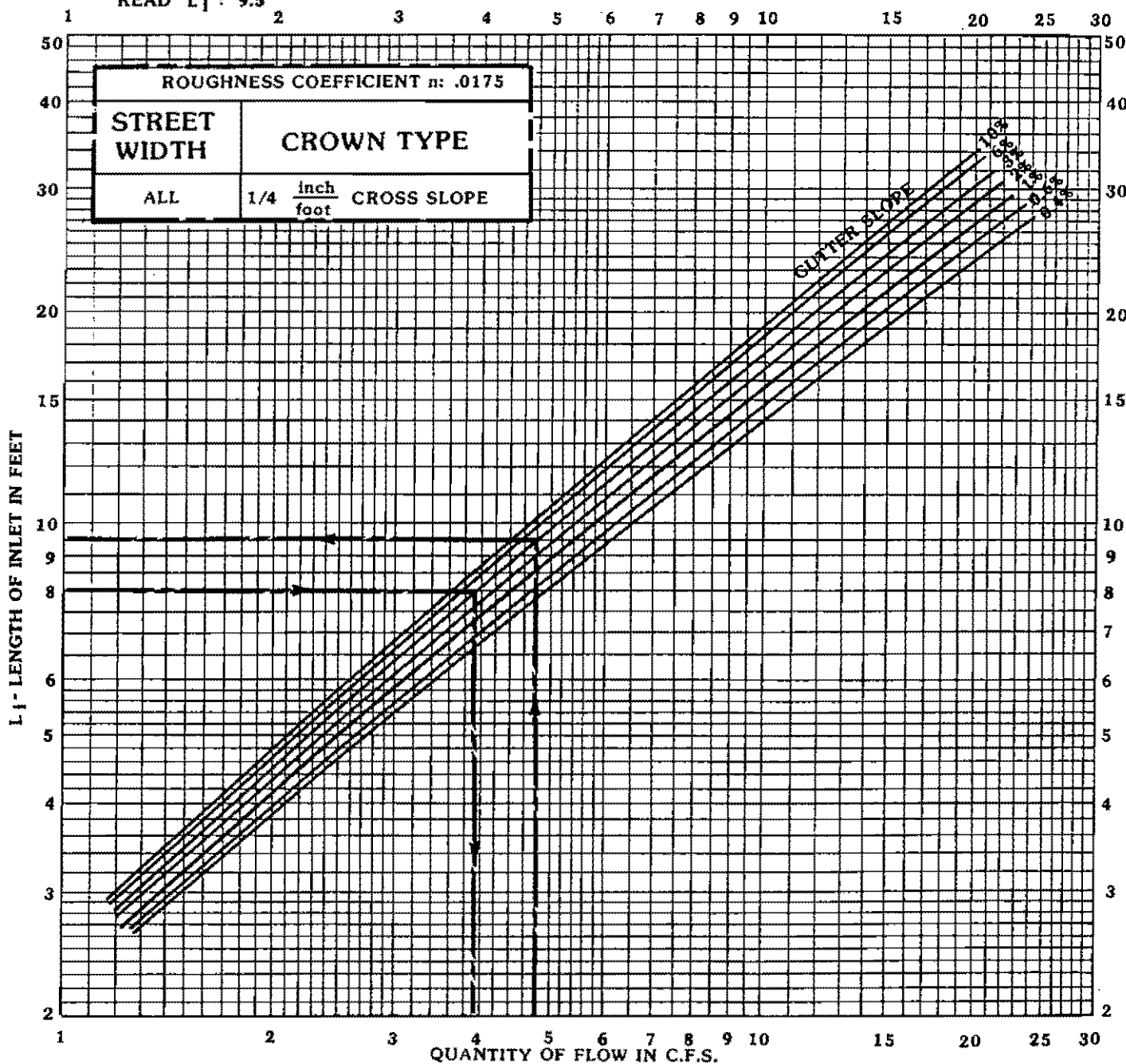

# RECESSED AND STANDARD CURB OPENING INLET CAPACITY CURVES ON GRADE

FIGURE 10

**EXAMPLE**

**KNOWN:**

- PAVEMENT WIDTH : 40'
- GUTTER SLOPE: 1.0%
- 6" PARABOLIC CROWN
- GUTTER FLOW: 6.5 c.f.s.

**FIND:**

LENGTH OF INLET REQUIRED

**SOLUTION:**

- ENTER GRAPH AT 6.5 c.f.s.
- INTERSECT SLOPE: 1.0 %
- READ  $L_1$ : 10'

**DECISION:**

1. USE 10' INLET  
NO FLOW REMAINS IN GUTTER
2. USE 8' INLET  
INTERCEPT ONLY PART OF FLOW  
USE 8' INLET  
ENTER GRAPH AT  $L_1$ : 8'  
INTERSECT SLOPE: 1.0%  
READ Q: 5.0 c.f.s.  
REMAINING GUTTER FLOW: 6.5 c.f.s. - 5.0 cfs = 1.5

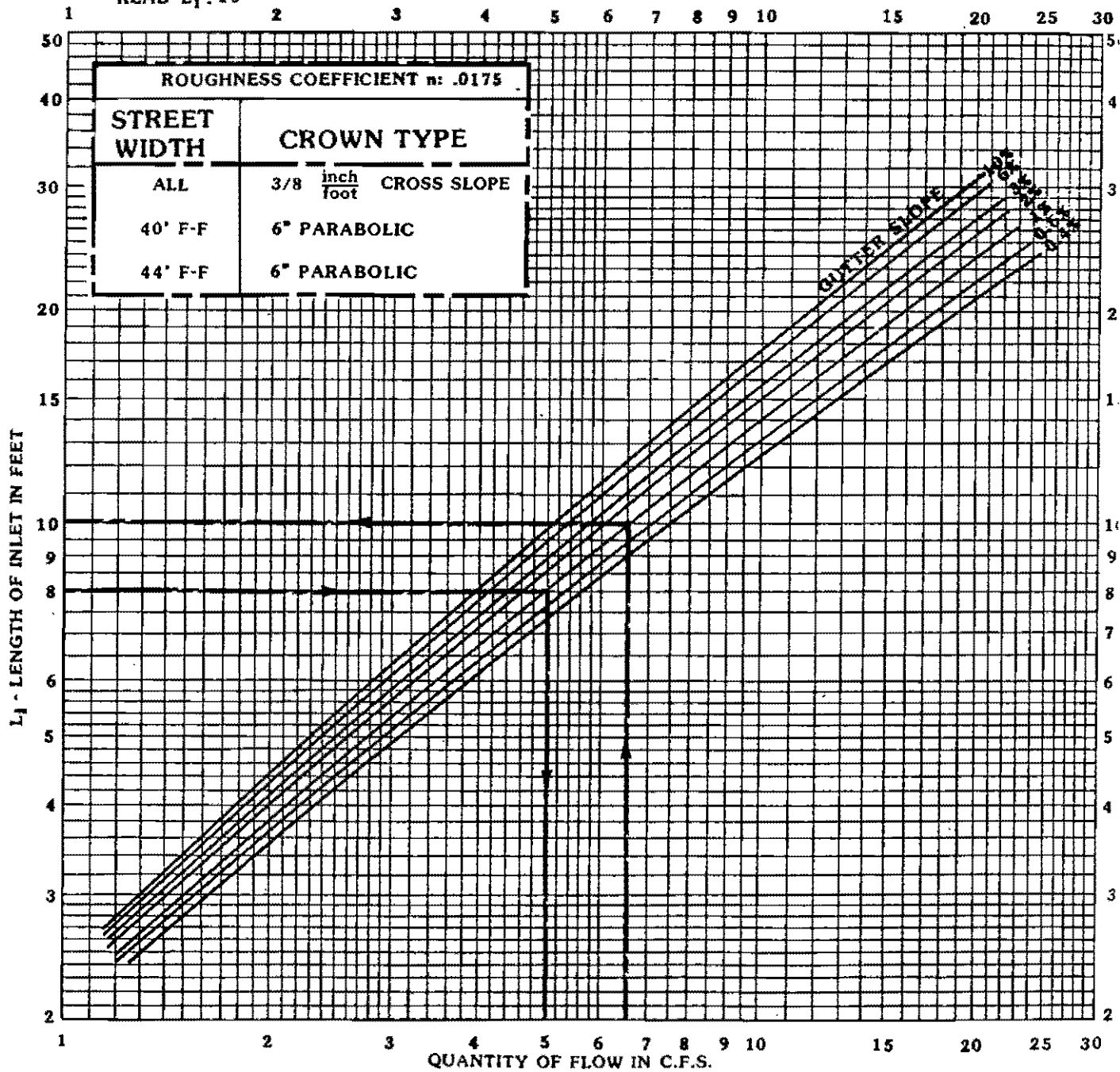

# RECESSED AND STANDARD CURB OPENING INLET CAPACITY CURVES ON GRADE

FIGURE 11

**EXAMPLE**

**KNOWN:**

PAVEMENT WIDTH : 12'

ALLEY SLOPE: 0.4%

QUANTITY OF FLOW: 10.5 c.f.s.

**FIND:**

LENGTH OF INLET REQUIRED

**SOLUTION:**

ENTER GRAPH AT 10.5 c.f.s.

INTERSECT SLOPE: 0.4%

READ  $L_i$  : 13.0 ft.

**DECISION:**

1. USE 14' INLET

NO FLOW REMAINS IN GUTTER

2. USE 10' INLET

INTERCEPT ONLY PART OF FLOW

USE 10' INLET

ENTER GRAPH AT  $L_i$  : 10'

INTERSECT SLOPE: 0.4%

READ Q: 7.3 c.f.s.

REMAINING FLOW IN ALLEY : 10.5 c.f.s. - 7.3 c.f.s. = 3.2 c.f.s.

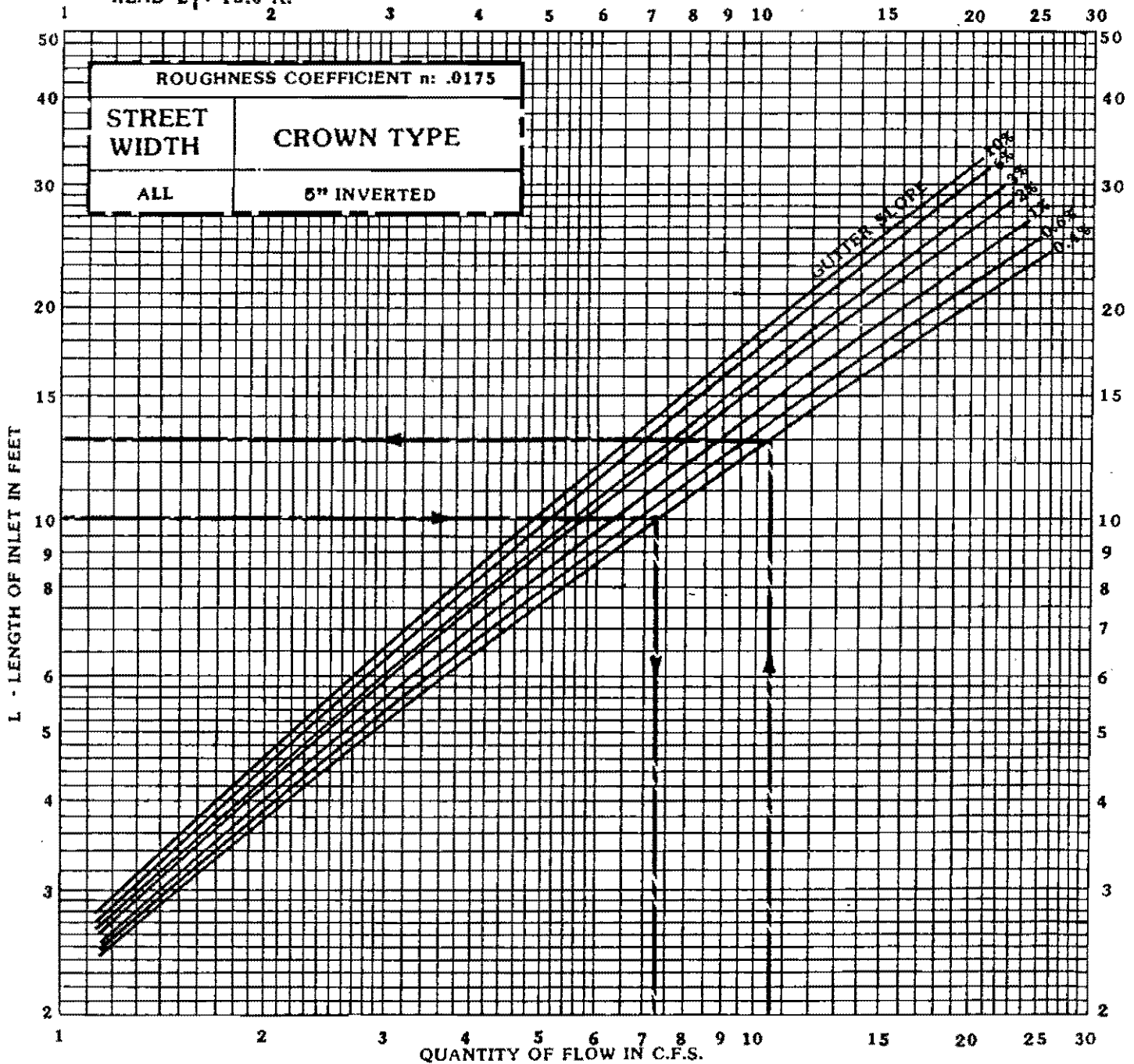

# RECESSED AND STANDARD CURB OPENING INLET CAPACITY CURVES AT LOW POINT

FIGURE 12

## EXAMPLE

KNOWN:

QUANTITY OF FLOW: 19.0 c.f.s.  
 MAXIMUM DEPTH OF FLOW DESIRED  
 IN GUTTER AT LOW POINT ( $y_0$ ): 0.5'

FIND:

LENGTH OF INLET REQUIRED ( $L_i$ )

SOLUTION:

ENTER GRAPH AT 19 c.f.s.  
 INTERSECT  $y_0 = 0.5'$   
 READ  $L_i : 9.0'$   
 USE 10' INLET

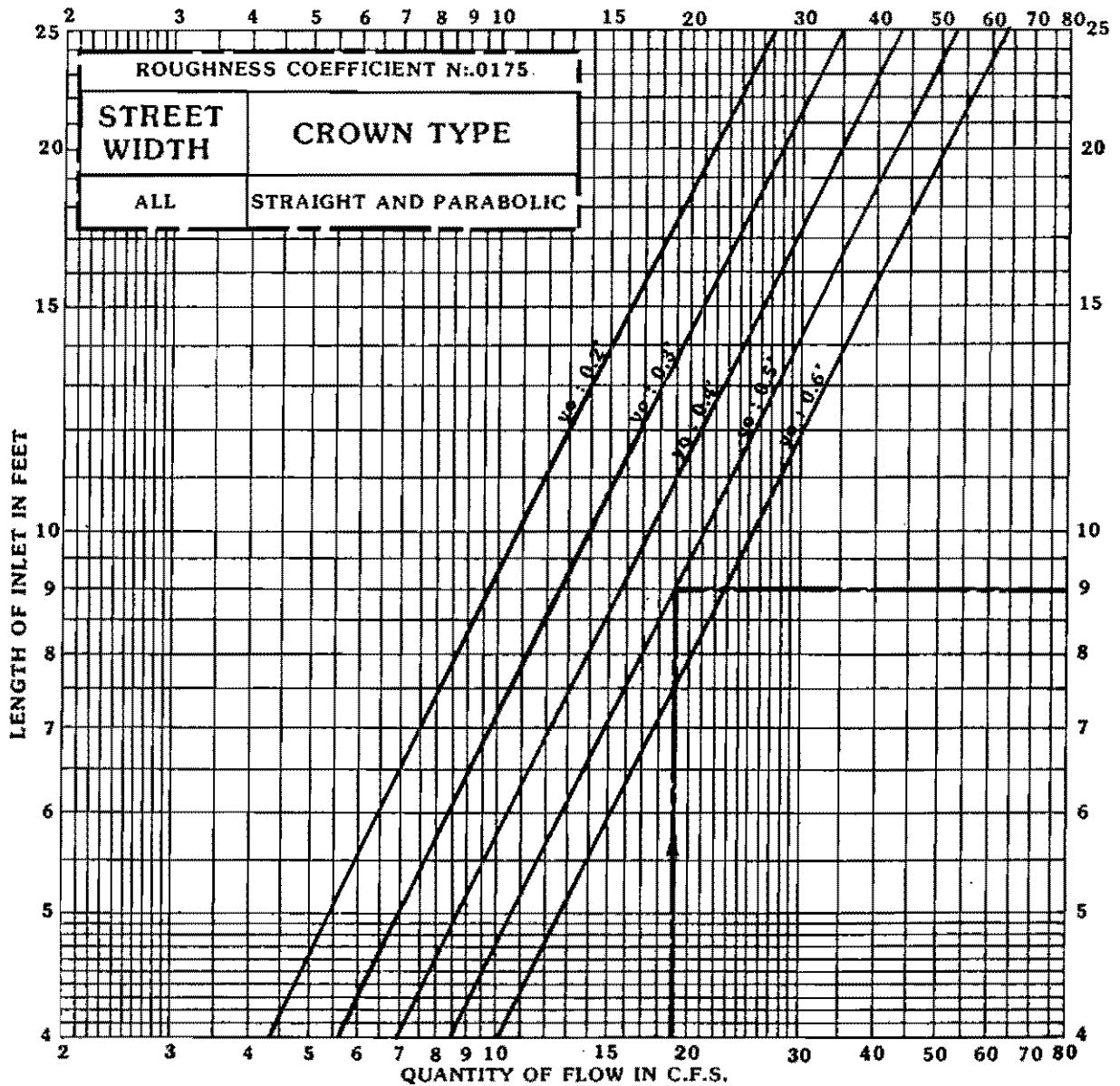

# TWO GRATE COMBINATION INLET CAPACITY CURVES ON GRADE

FIGURE 13

## EXAMPLE

**KNOWN:**

QUANTITY OF FLOW: 9 c.f.s.  
GUTTER SLOPE: 3.0%

**FIND:**

CAPACITY OF TWO GRATE  
COMBINATION INLET

**SOLUTION:**

ENTER GRAPH AT 9.0 c.f.s.  
INTERSECT SLOPE: 3.0 %  
READ PERCENT OF FLOW  
INTERCEPTED: 61%  
61% OF 9.0 c.f.s. : 5.5 c.f.s.  
AS CAPACITY OF TWO GRATE  
COMBINATION INLET  
REMAINING GUTTER FLOW:  
9.0 c.f.s. - 5.2 c.f.s. : 3.8 c.f.s.

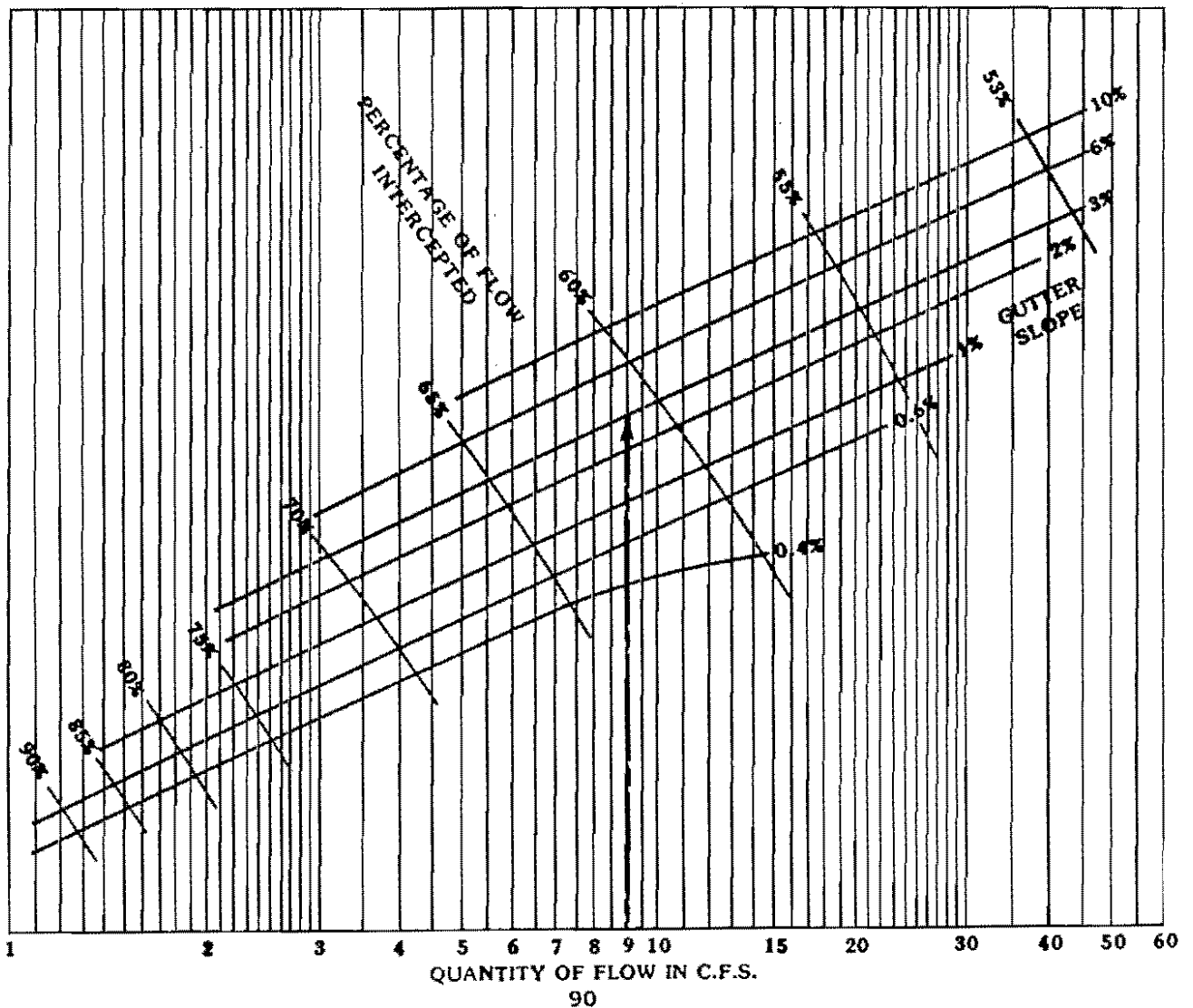

# THREE GRATE COMBINATION INLET CAPACITY CURVES ON GRADE

FIGURE 14

## EXAMPLE

**KNOWN:**

QUANTITY OF FLOW: 15 c.f.s.

GUTTER SLOPE: 2.0 %

**FIND:**

CAPACITY OF THREE GRATE INLET

**SOLUTION:**

ENTER GRAPH AT 15 c.f.s.

INTERSECT SLOPE: 2.0 %

READ PERCENT OF FLOW

INTERCEPTED: 62%

62 % OF 15 c.f.s.: 9.3 c.f.s.

AS CAPACITY OF THREE GRATE INLET

REMAINING GUTTER FLOW:

15 c.f.s.-9.3 c.f.s. : 5.7 c.f.s.

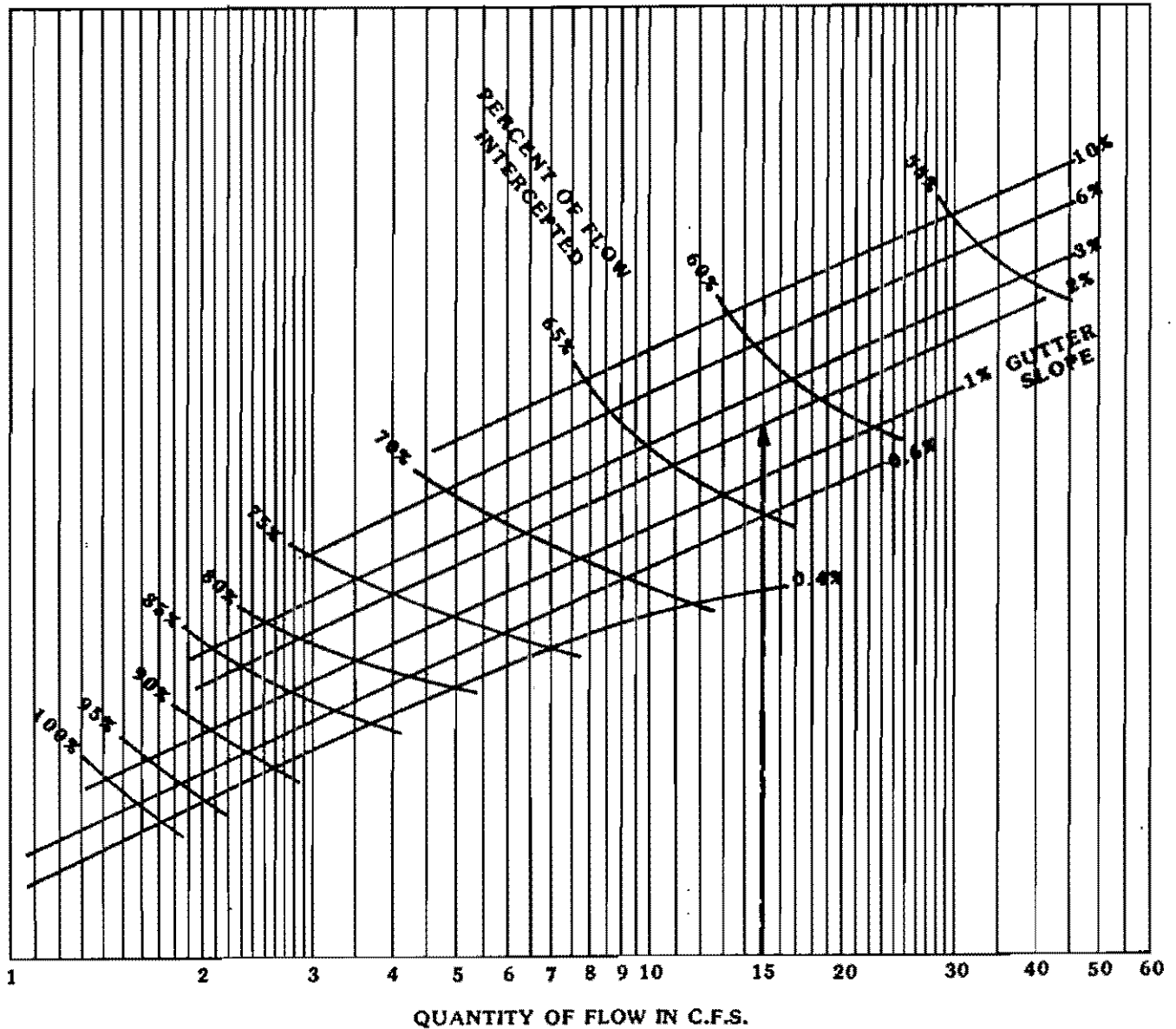

# FOUR GRATE COMBINATION INLET CAPACITY CURVES ON GRADE

FIGURE 15

## EXAMPLE

**KNOWN:**

QUANTITY OF FLOW: 12 c.f.s.

GUTTER SLOPE: 2.0 %

**FIND:**

CAPACITY OF FOUR GRATE COMBINATION  
INLET

**SOLUTION:**

ENTER GRAPH AT 12 c.f.s.

INTERSECT SLOPE: 2.0 %

READ PERCENT OF FLOW

INTERCEPTED: 68 %

68 % OF 12 c.f.s.: 8.2 c.f.s.

AS CAPACITY OF 4 GRATE COMBINATION INLET

REMAINING GUTTER FLOW:

12 c.f.s.-8.2 c.f.s. : 3.8 c.f.s.

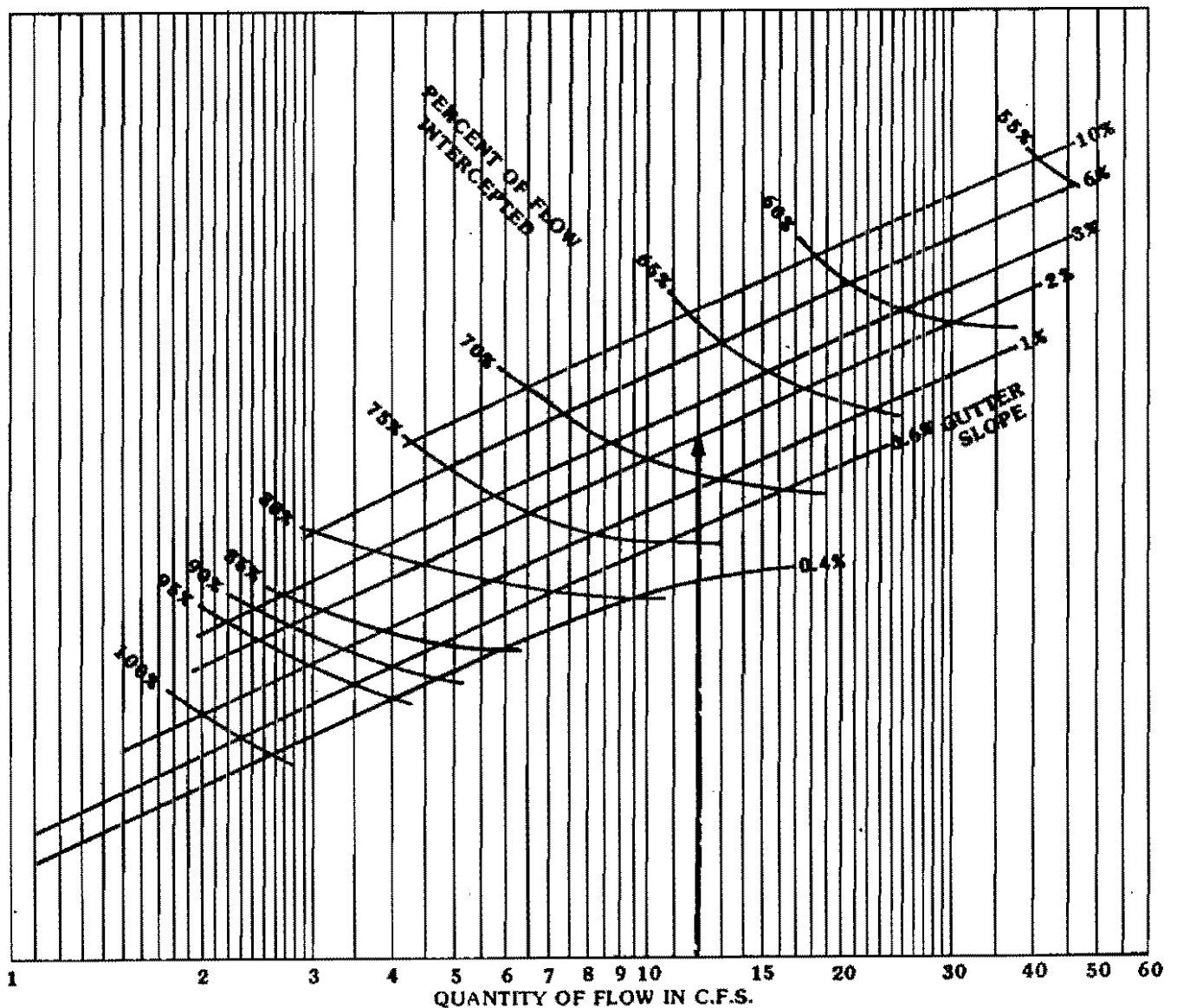

# COMBINATION INLET CAPACITY CURVES AT LOW POINT

FIGURE 16

## EXAMPLE

**KNOWN :**

QUANTITY OF FLOW : 20.0 c.f.s.  
 MAXIMUM DEPTH OF FLOW DESIRED  
 AT LOW POINT ( $y_o$ ) : 0.5'

**FIND :**

LENGTH OF INLET REQUIRED (LI)

**SOLUTION :**

ENTER GRAPH AT 20.0 c.f.s.

INTERSECT  $y_o$  : 0.5'

READ LI : 8.4

USE 10' INLET

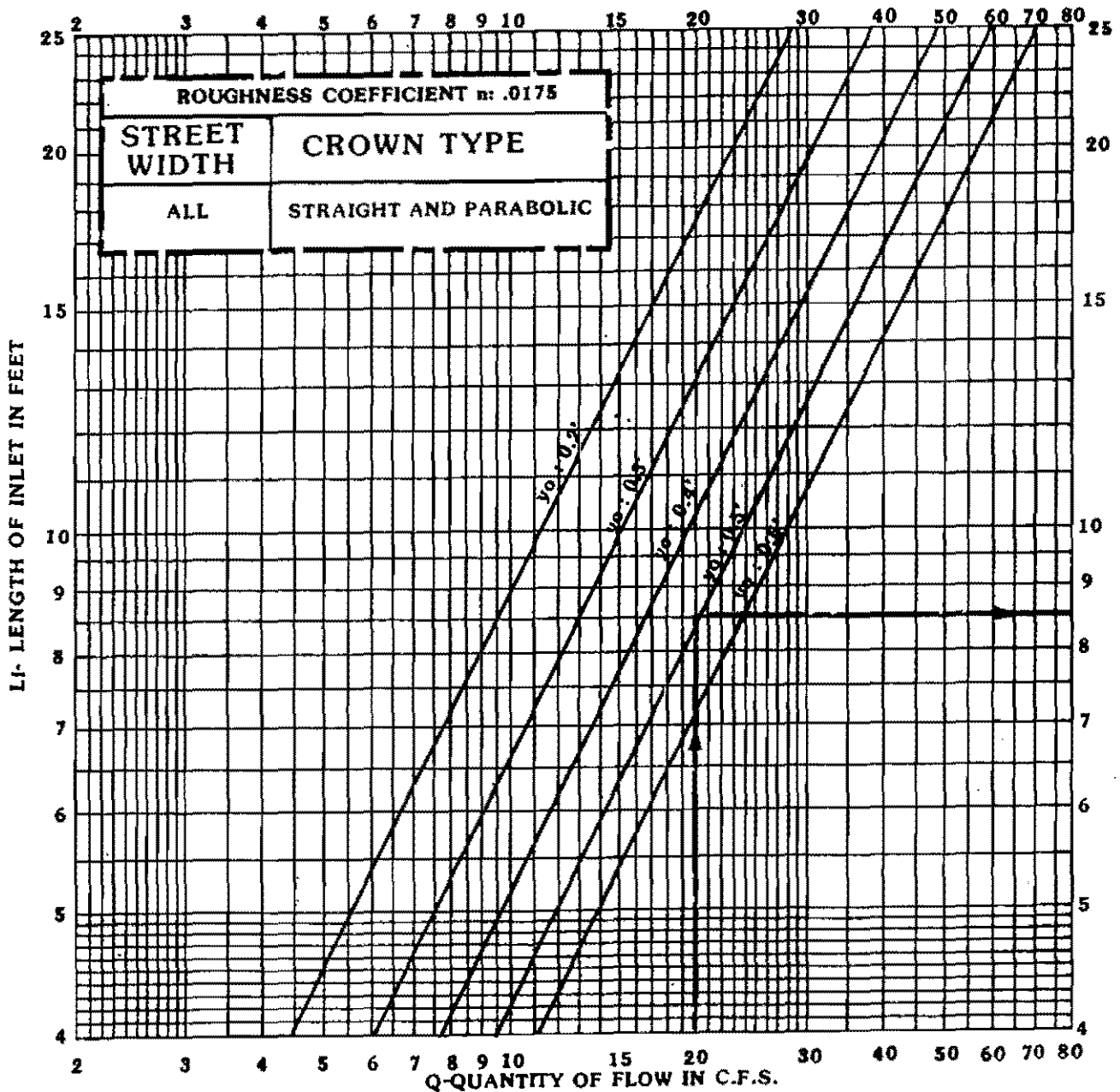



# TWO GRATE INLET CAPACITY CURVES ON GRADE

FIGURE 17

## EXAMPLE

**KNOWN:**

QUANTITY OF FLOW: 5.0 c.f.s.

GUTTER SLOPE: 0.6 %

**FIND:**

CAPACITY OF TWO GRATE INLET

**SOLUTION:**

ENTER GRAPH AT 5.0 c.f.s.

INTERSECT SLOPE: 0.6 %

READ PERCENT OF FLOW

INTERCEPTED: 63%

63 % OF 5.0 c.f.s. : 3.2 c.f.s.

AS CAPACITY OF TWO GRATE INLET

REMAINING GUTTER FLOW:

5.0 c.f.s. - 3.2 c.f.s. : 1.8 c.f.s.

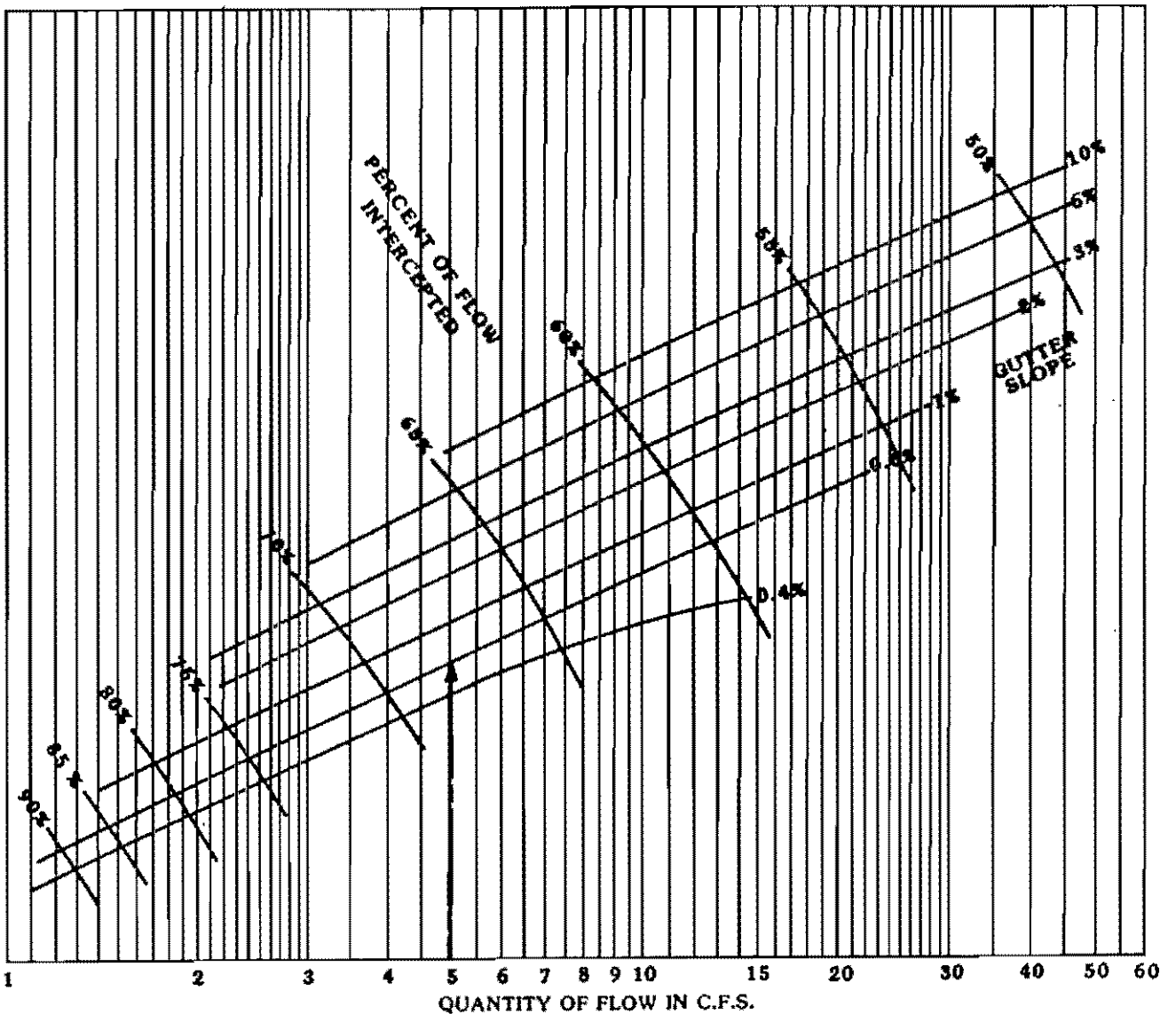

# FOUR GRATE INLET CAPACITY CURVES ON GRADE

FIGURE 18

## EXAMPLE

**KNOWN:**

QUANTITY OF FLOW: 20 c.f.s.

GUTTER SLOPE: 1.0 %

**FIND:**

CAPACITY OF FOUR GRATE INLET

**SOLUTION:**

ENTER GRAPH AT 20 c.f.s.

INTERSECT SLOPE: 1.0 %

READ PERCENT OF FLOW

INTERCEPTED: 63 %

63 % OF 20 c.f.s.: 12.6 c.f.s.

AS CAPACITY OF FOUR GRATE INLET

REMAINING GUTTER FLOW:

$20.0 \text{ c.f.s.} - 12.6 \text{ c.f.s.} = 7.4 \text{ c.f.s.}$

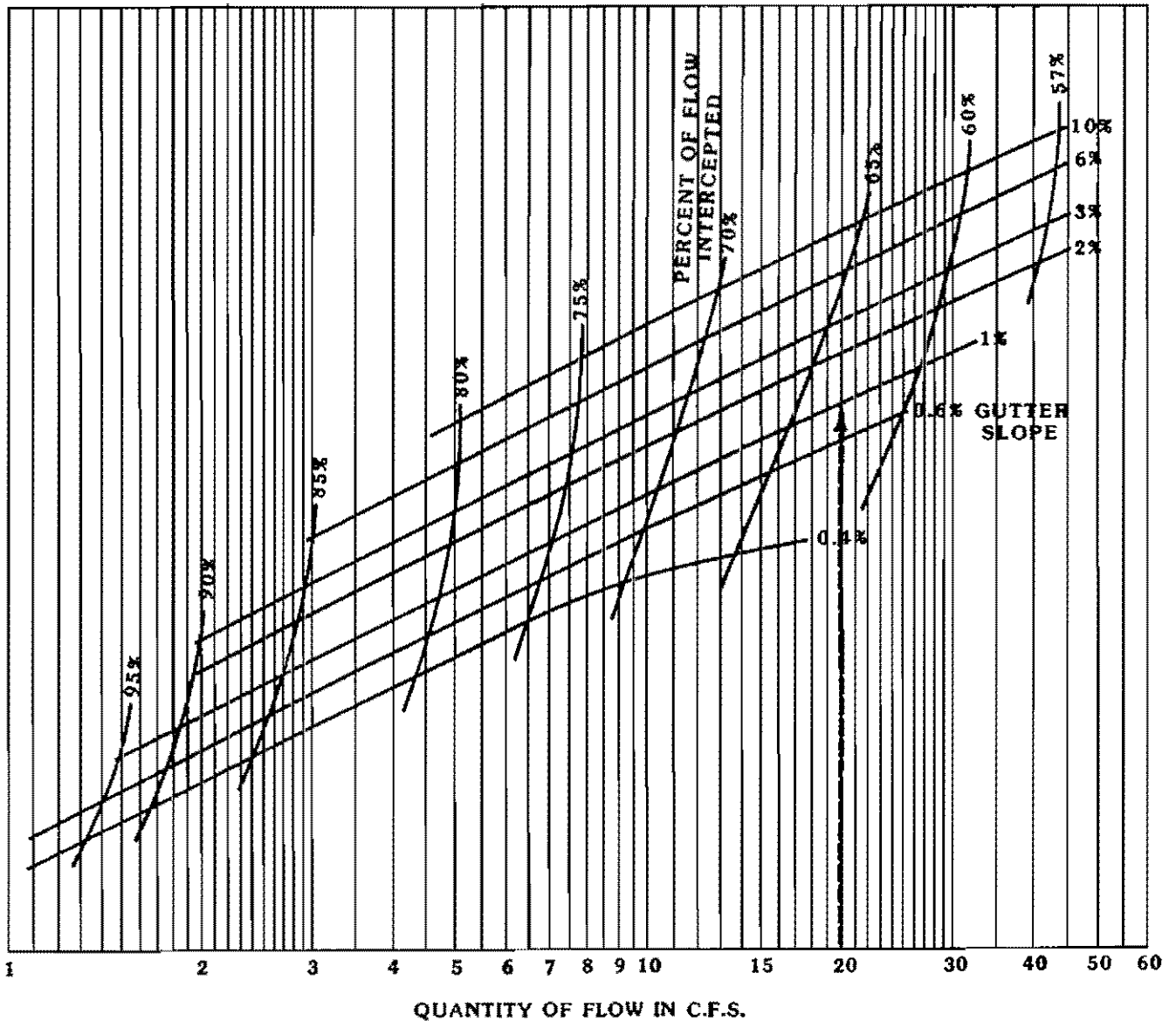

# SIX GRATE INLET CAPACITY CURVES ON GRADE

FIGURE 19

## EXAMPLE

**KNOWN:**

QUANTITY OF FLOW: 4.0 c.f.s.

GUTTER SLOPE: 3.0 %

**FIND:**

CAPACITY OF SIX GRATE INLET

**SOLUTION:**

ENTER GRAPH AT 4.0 c.f.s.

INTERSECT SLOPE: 3.0 %

READ PERCENT OF FLOW

INTERCEPTED: 85%

85% OF 4.0 c.f.s.: 3.4 c.f.s.

AS CAPACITY OF SIX GRATE INLET

REMAINING GUTTER FLOW:

4.0 c.f.s. - 3.4 c.f.s. : 0.6 c.f.s.

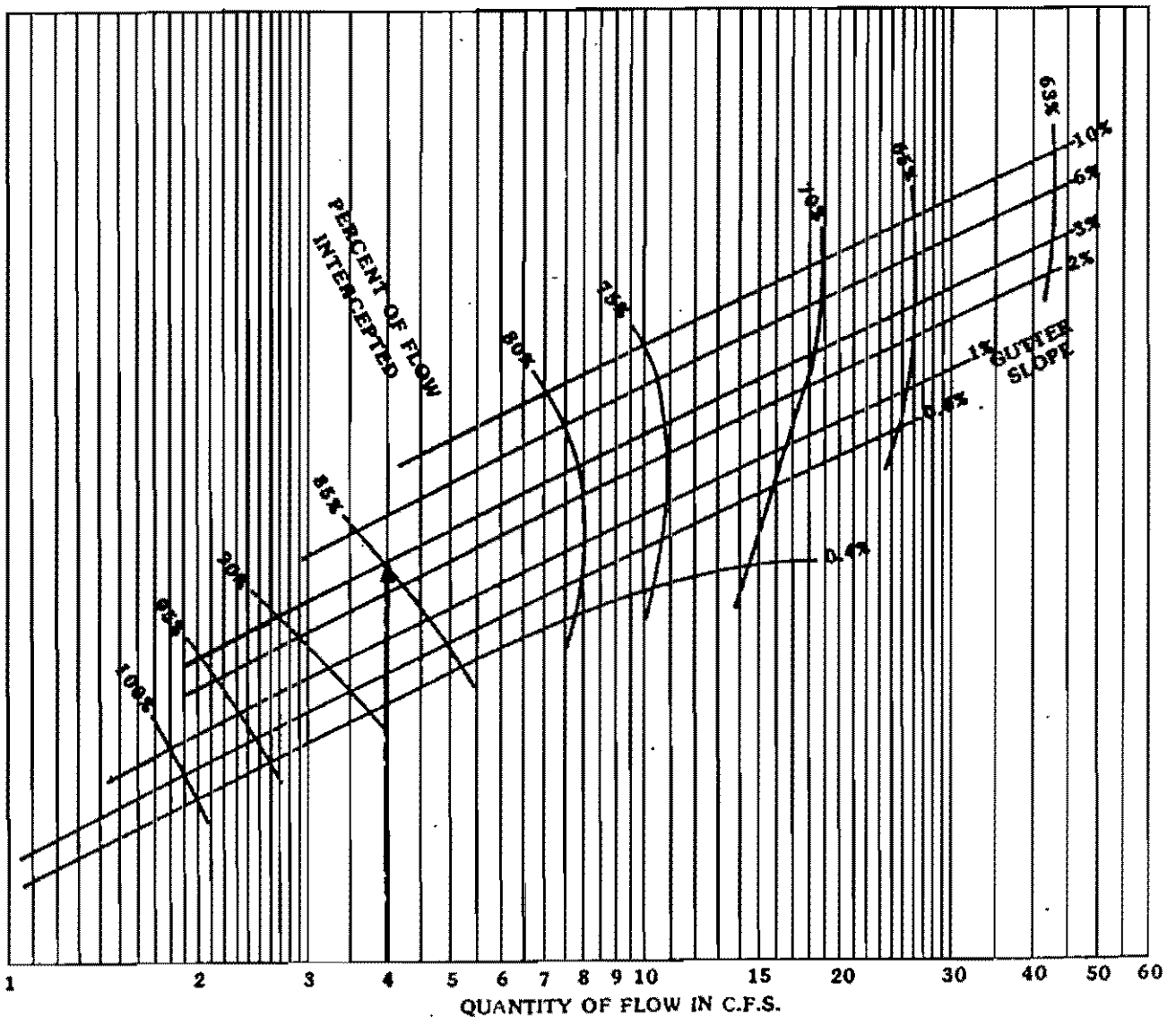

# GRATE INLET CAPACITY CURVES AT LOW POINT

FIGURE 20

## EXAMPLE

### KNOWN:

QUANTITY OF FLOW: 4.8 c.f.s.

MAXIMUM DEPTH OF FLOW DESIRED  
AT LOW POINT: 0.4'

### FIND:

INLET REQUIRED

### SOLUTION:

ENTER GRAPH AT 4.8 c.f.s.

INTERSECT 3 - GRATE AT 0.28'

INTERSECT 2 - GRATE AT 0.63'

USE 3 - GRATE

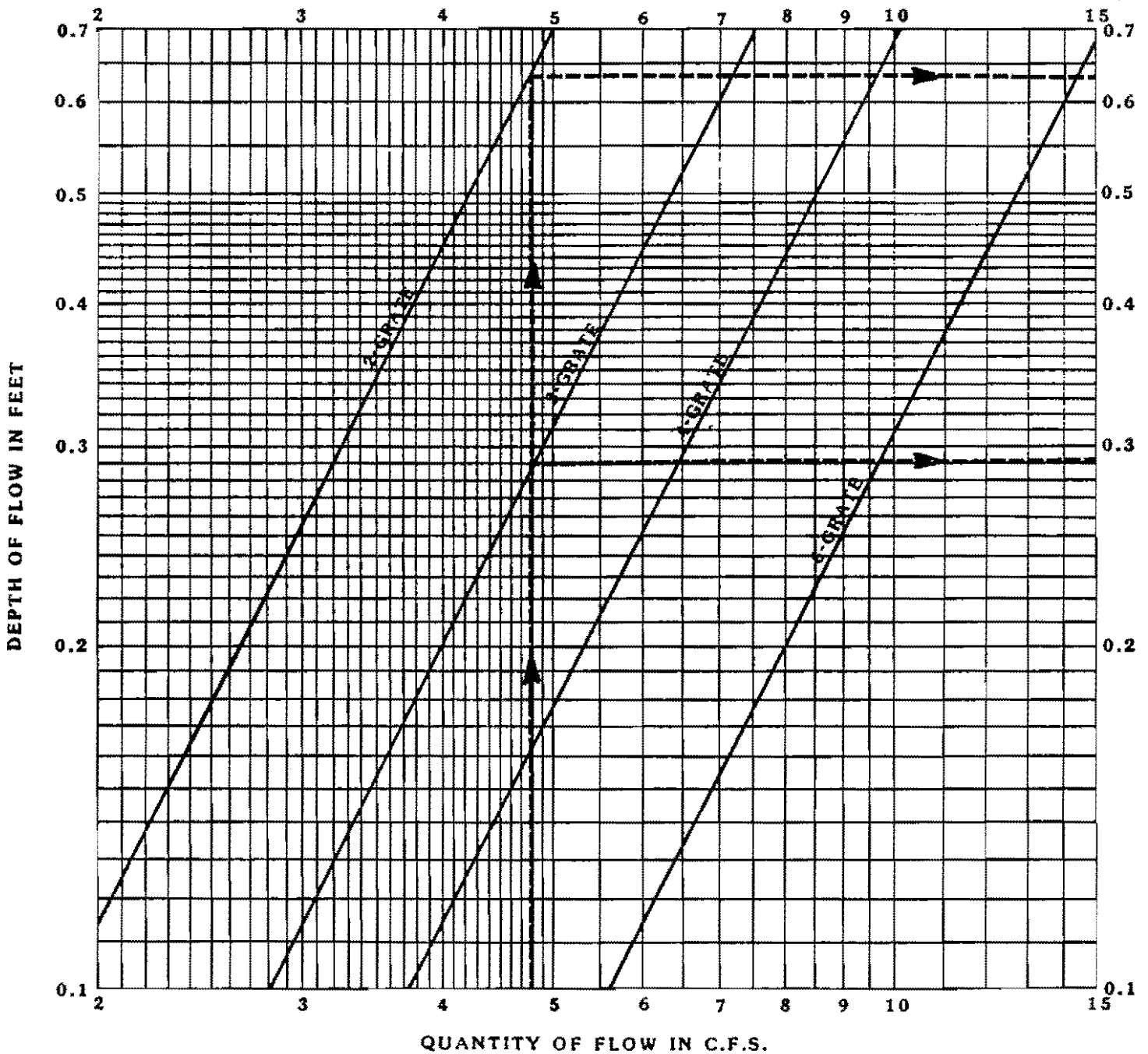

# DROP INLET CAPACITY CURVES AT LOW POINT

FIGURE 21

## EXAMPLE

KNOWN:

QUANTITY OF FLOW: 12 c.f.s.

MAXIMUM DEPTH OF FLOW

DESIRED ( $y_o$ ): 0.5'

FIND:

LENGTH OF INLET OPENING REQUIRED

( $L_j$ )

SOLUTION:

ENTER GRAPH AT 12 c.f.s.

INTERSECT  $y_o$ : 0.5'

READ  $L_j$ : 12.3

USE 12.3 OF INLET 4x4

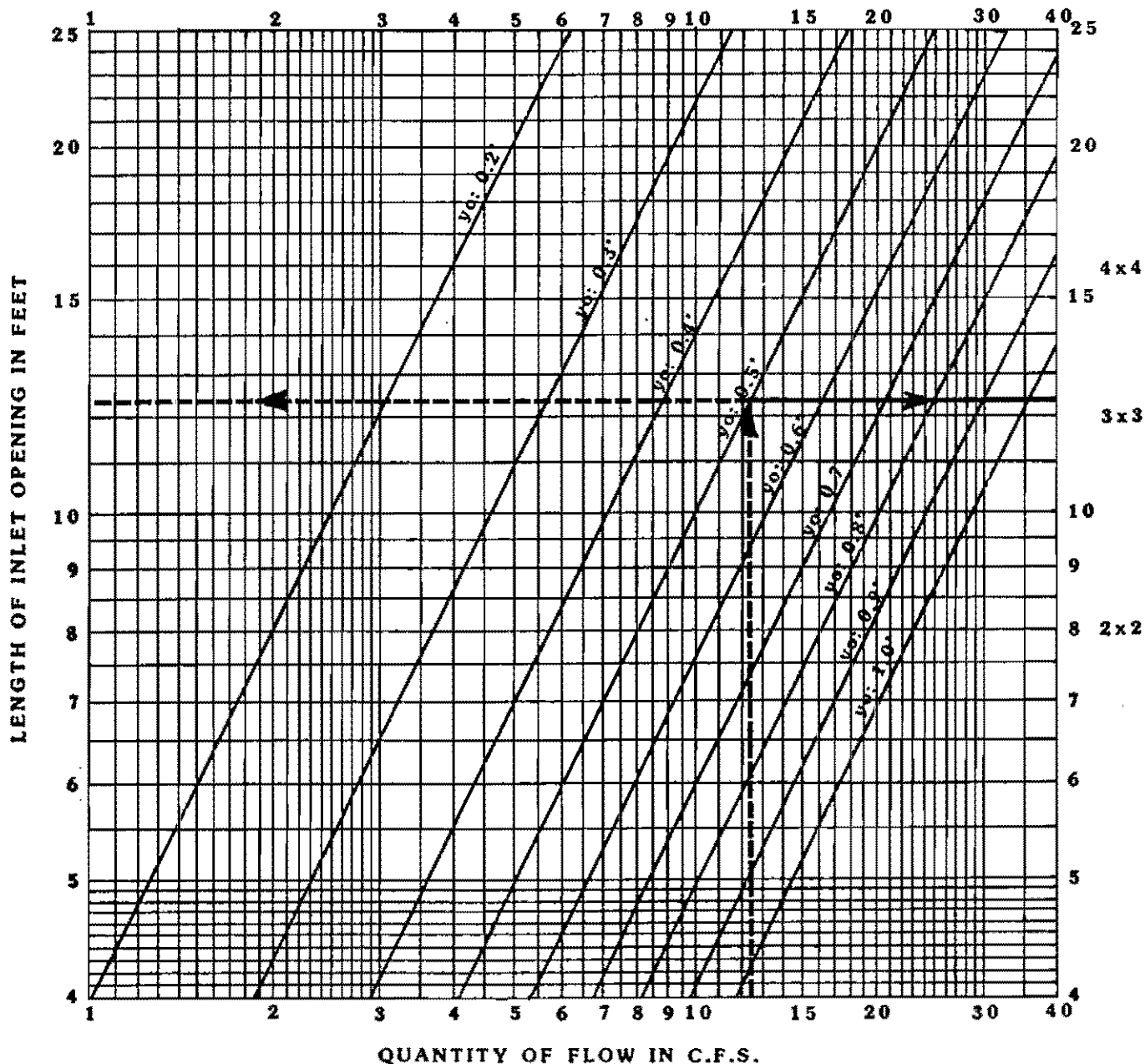

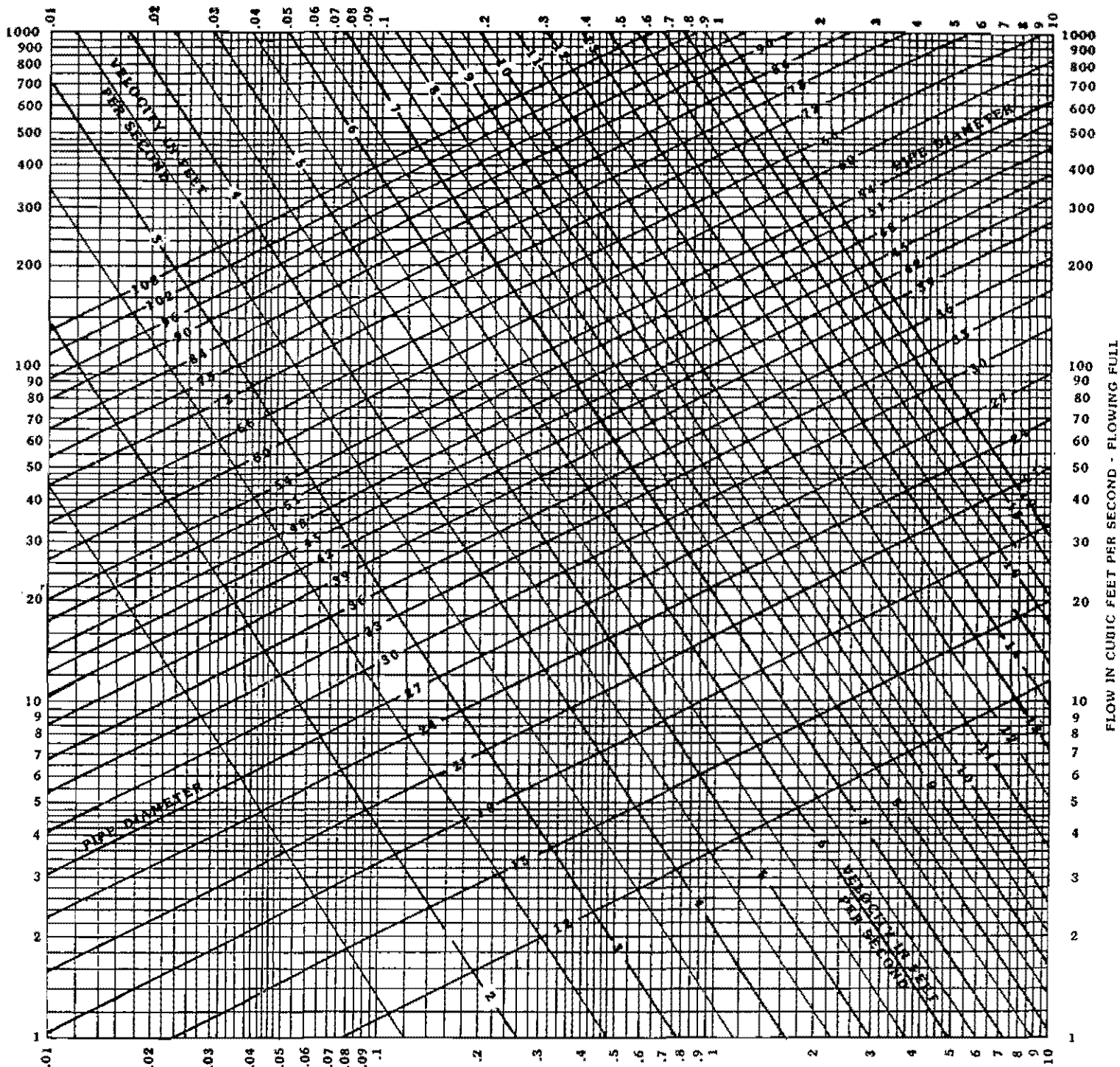

SLOPE OF PIPE IN FEET PER 100 FEET

### CAPACITY OF CIRCULAR PIPES FLOWING FULL

FIGURE 22

A GRAPHICAL SOLUTION  
OF  
MANNING'S EQUATION

$$V = \frac{1.486}{n} R^{2/3} S^{1/2}$$

n : 0.013

# OUTFALL OF A STORM SEWER INTO A CHANNEL

FIGURE 23

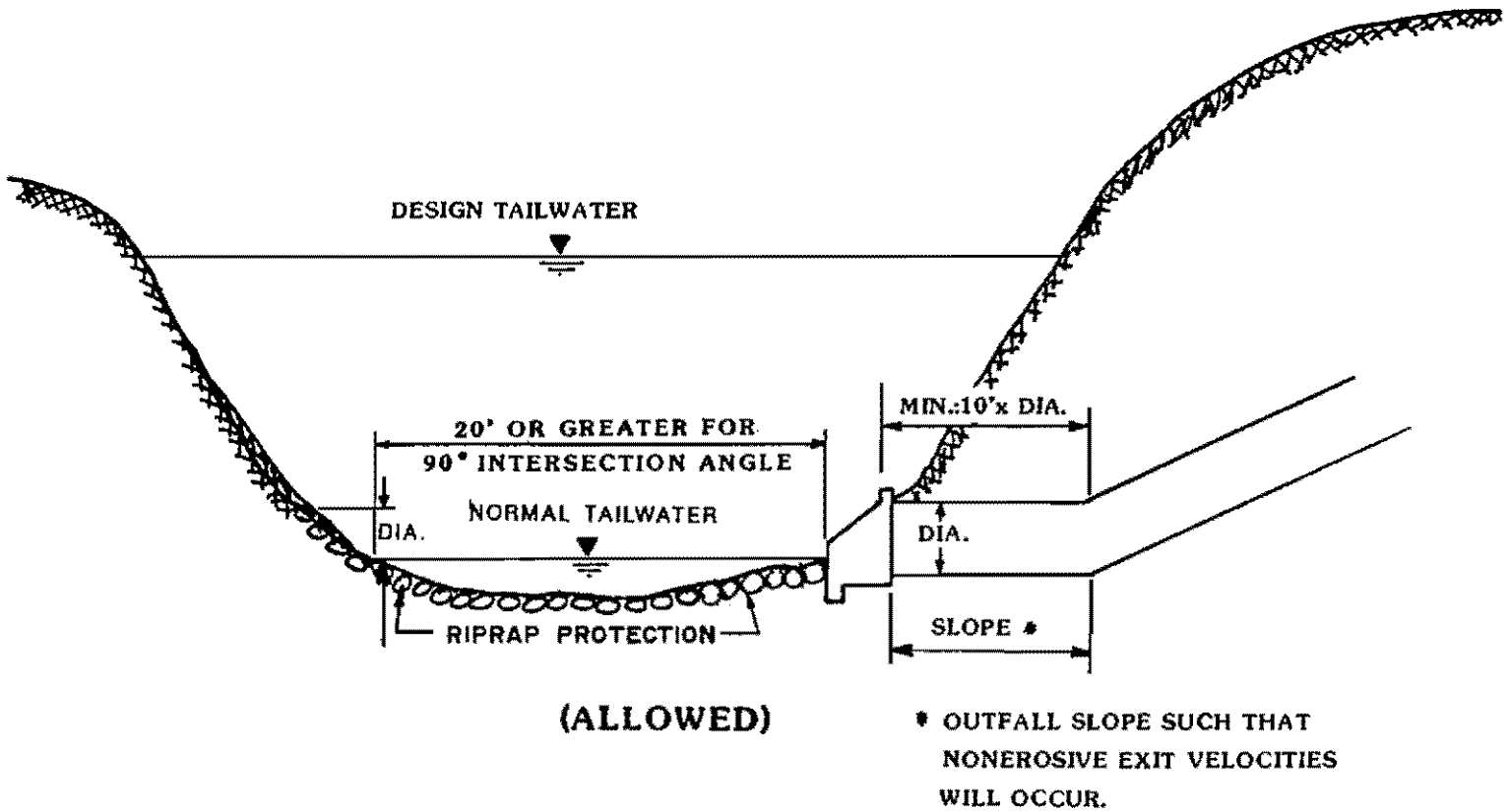
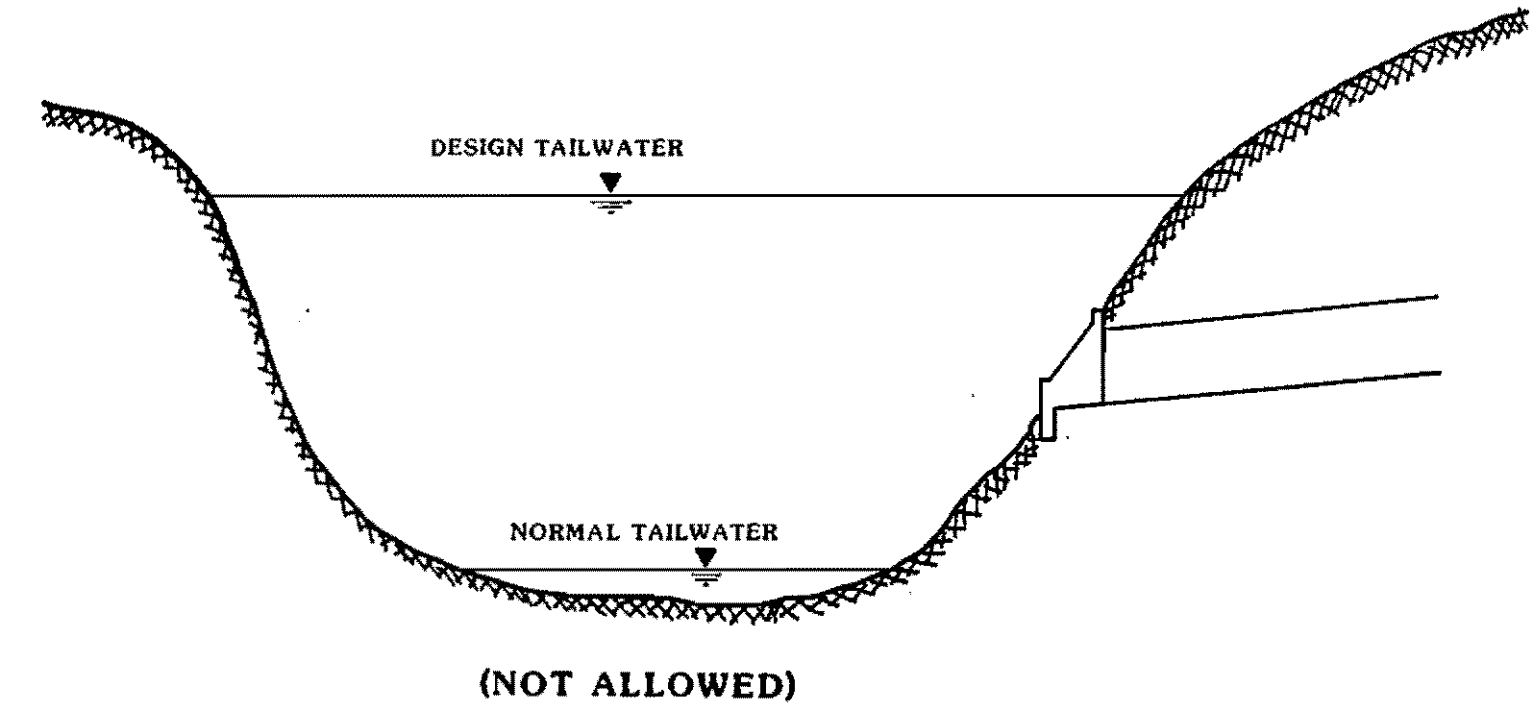
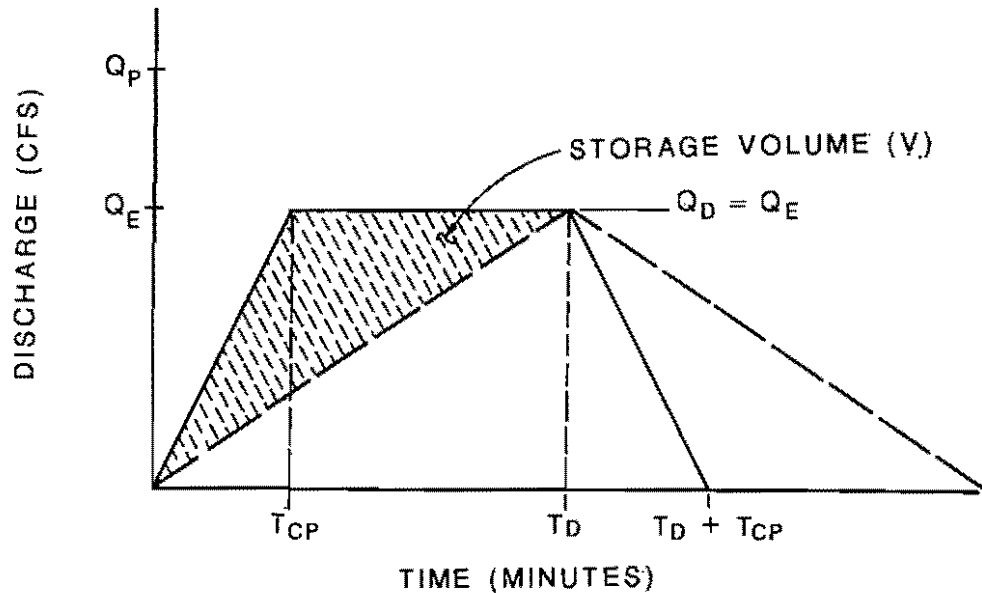

FIGURE 24

Approximate Routing Method for Watersheds < 160 Acres



$$V = (60) [ (Q_D [ (T_D - T_{CP}) + (T_D + T_{CP}) ] / 2) - (Q_E [ T_{CP} + T_D ] / 2) ]$$

in cubic feet.

or

$$V = 60 (Q_E / 2) (T_D - T_{CP})$$

Where:  $Q_P$  = Peak discharge in cfs for developed watershed using storm duration equal to  $T_{CP}$ .

$Q_E$  = Peak discharge in cfs for existing watershed, assuming full residential development and corresponding  $T_C$ .

$Q_D$  = Peak discharge in cfs for developed watershed, based on a storm duration that yields the existing discharge for  $C_p$  and  $A$ .

$T_{CP}$  = Time of concentration in minutes for proposed development.

$T_D$  = Storm duration in minutes corresponding to  $I_D$ .

$I_D$  = Rainfall intensity (inches/hour) for a storm duration that produces  $Q_D$  and is calculated using the following formula:

$$I_D = \frac{Q_D}{(C_P A) C_f}$$

Where:

$C_P$  = Rational "C" for developed condition.

$A$  = Drainage area in acres.

$C_f$  = Frequency factor coefficient of 1.25



FIGURE 24, continued

Detention Basin Example:

Development Data:

Drainage Area	=	160 acres
Residential C	=	0.55
Residential $T_{CR}$	=	15 minutes
Developed $C_p$	=	0.70
Developed $T_{CP}$	=	10 minutes
$C_f$	=	1.25

For the 100-year storm:

$$I_{RES} = 7.52 \text{ in/hour (from Figure 1)}$$

$$I_P = 8.82 \text{ in/hour.}$$

$$Q_E = Q_D = (1.25) (0.55) (7.52) (160) = 827 \text{ cfs}$$

$$Q_P = (1.25) (0.70) (8.82) (160) = 1235 \text{ cfs}$$

$$I_D = \frac{Q_D}{(C_p A) C_f} = \frac{827}{(.7)(160)(1.25)} = 5.91 \text{ in/hour}$$

From Figure 1, for  $I_D = 5.91$  in/hour,

$$T_D = 28 \text{ minutes}$$

$$V = 60 \left( \frac{827}{2} \right) (28-10)$$

$$= 24,810 (18) = 446,580 \text{ cubic feet}$$

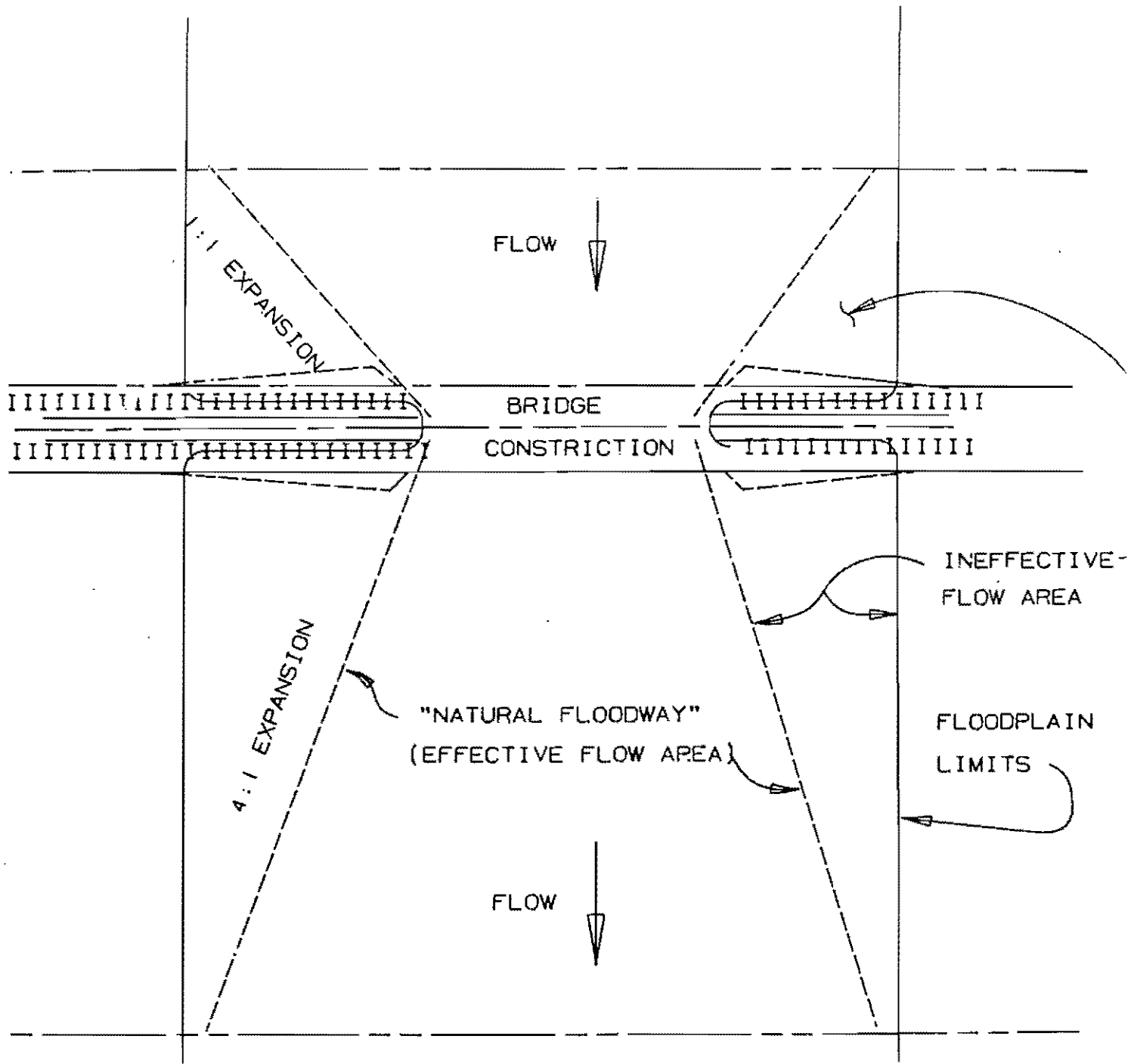

FIGURE 25. "NATURAL FLOODWAY" EXAMPLE