

ACORD CERTIFICATE OF LIABILITY INSURANCE		DATE (MM/DD/YY) 04/30/03
PRODUCER TIM BROOKS 2602 RIDGE ROAD STE 1 ROCKWALL, TEXAS 75087 972-771-1999	THIS CERTIFICATE IS ISSUED AS A MATTER OF INFORMATION ONLY AND CONFERS NO RIGHTS UPON THE CERTIFICATE HOLDER. THIS CERTIFICATE DOES NOT AMEND, EXTEND OR ALTER THE COVERAGE AFFORDED BY THE POLICIES BELOW.	
INSURERS AFFORDING COVERAGE		
INSURED ALL SEASONS DECK 9647 SUNSET DRIVE LAVON, TEXAS 75166-1608	INSURER A: COLONY GROUP	
	INSURER B:	
	INSURER C:	
	INSURER D:	
	INSURER E:	

COVERAGES

THE POLICIES OF INSURANCE LISTED BELOW HAVE BEEN ISSUED TO THE INSURED NAMED ABOVE FOR THE POLICY PERIOD INDICATED. NOTWITHSTANDING ANY REQUIREMENT, TERM OR CONDITION OF ANY CONTRACT OR OTHER DOCUMENT WITH RESPECT TO WHICH THIS CERTIFICATE MAY BE ISSUED OR MAY PERTAIN, THE INSURANCE AFFORDED BY THE POLICIES DESCRIBED HEREIN IS SUBJECT TO ALL THE TERMS, EXCLUSIONS AND CONDITIONS OF SUCH POLICIES. AGGREGATE LIMITS SHOWN MAY HAVE BEEN REDUCED BY PAID CLAIMS.

INSR LTR	TYPE OF INSURANCE	POLICY NUMBER	POLICY EFFECTIVE DATE (MM/DD/YYYY)	POLICY EXPIRATION DATE (MM/DD/YYYY)	LIMITS
A	GENERAL LIABILITY	BINDER	04/30/03	04/30/04	EACH OCCURRENCE \$ 1,000,000
	<input checked="" type="checkbox"/> COMMERCIAL GENERAL LIABILITY				FIRE DAMAGE (Any one fire) \$ 100,000
	<input type="checkbox"/> CLAIMS MADE <input checked="" type="checkbox"/> OCCUR				MEQ EXP (Any one person) \$ 5,000
					PERSONAL & ADV INJURY \$ 1,000,000
					GENERAL AGGREGATE \$ 2,000,000
					PRODUCTS - COMPROP AGG \$ 2,000,000
					GEN'L AGGREGATE LIMIT APPLIES PER: <input type="checkbox"/> POLICY <input type="checkbox"/> PRD. JECT <input type="checkbox"/> LOC
	AUTOMOBILE LIABILITY				COMBINED SINGLE LIMIT (Ea accident) \$
	<input type="checkbox"/> ANY AUTO				BODILY INJURY (Per person) \$
	<input type="checkbox"/> ALL OWNED AUTOS				BODILY INJURY (Per accident) \$
	<input type="checkbox"/> SCHEDULED AUTOS				PROPERTY DAMAGE (Per accident) \$
	<input type="checkbox"/> HIRED AUTOS				
	<input type="checkbox"/> NON-OWNED AUTOS				
	GARAGE LIABILITY				AUTO ONLY - EA ACCIDENT \$
	<input type="checkbox"/> ANY AUTO				OTHER THAN EA ACC \$
					AUTO ONLY: AGG \$
	EXCESS LIABILITY				EACH OCCURRENCE \$
	<input type="checkbox"/> OCCUR <input type="checkbox"/> CLAIMS MADE				AGGREGATE \$
	<input type="checkbox"/> DEDUCTIBLE				\$
	<input type="checkbox"/> RETENTION \$				\$
	WORKERS COMPENSATION AND EMPLOYERS' LIABILITY				WC STATUTORY LIMITS OTH-ER
					E.L. EACH ACCIDENT \$
					E.L. DISEASE - EA EMPLOYEE \$
					E.L. DISEASE - POLICY LIMIT \$
	OTHER				

DESCRIPTION OF OPERATIONS/LOCATIONS/VEHICLES/EXCLUSIONS ADDED BY ENDORSEMENT/SPECIAL PROVISIONS

CERTIFICATE HOLDER	ADDITIONAL INSURED: INSURER LETTER:	CANCELLATION
CITY OF ADDISON PO BOX 9010 ADDISON, TEXAS 75001		SHOULD ANY OF THE ABOVE DESCRIBED POLICIES BE CANCELLED BEFORE THE EXPIRATION DATE THEREOF, THE ISSUING INSURER WILL ENDEAVOR TO MAIL <u>10</u> DAYS WRITTEN NOTICE TO THE CERTIFICATE HOLDER NAMED TO THE LEFT, BUT FAILURE TO DO SO SHALL IMPOSE NO OBLIGATION OR LIABILITY OF ANY KIND UPON THE INSURER, ITS AGENTS OR REPRESENTATIVES.
		AUTHORIZED REPRESENTATIVE <i>Tim Brooks</i>

All Seasons Deck

9647 Sunset Dr.
Lavon, TX 75166

CONTRACT

I Joseph D. Renfro, DBA All Seasons Deck, do hereby agree to build the fore mentioned project, (450 sq ft. custom ramp with 90 linear ft of custom handrail stained & sealed to color of choice ramp and handrail material type to be treated pine) ramp and handrail to match drawing and pictures provided for a monetary sum of \$ 5, 910 of which 50% is due on the start date which is Tuesday, April 29 and (estimated) completion date is Saturday, May 3. Total amount due upon completion of the project. Structural design and assembly of entire project to meet or surpass all engineering or architectural specifications. Main beams and cross members of substructure to be 2x10s. Span of cross members to be no more than 6 ft. Joists of substructure to be 2x8s no more than 16 inches on center. All Seasons Deck takes full liability for total completion of the project. All Seasons Deck is to provide liability insurance. In accordance with the Texas Residential Construction Liability Act, I will fulfill my obligation to repair any problems within reason that may occur within one year after the completion date.

I have read and understand the above contract,

City of Addison J. Allen Date 4/25/03

Contractor J. D. Renfro Date 4/28/03

City of Addison
Jim Pierce

All Seasons Deck

"In pursuit of perfection"

Custom Decks

Designed & Assembled

(214) 683-0925

Fax

972-238-0344

PROPOSAL

Ramp

DECK	
Materials	Treated Pine
	4600 ⁰⁰
Sq. ft.	450 45x10
Stain	yes color of choice
Skirting	
Etc.	80° slope 3' over 45' w/s landing

ARBOR	
Materials	
Size	
Scroll	
Etc.	

BENCHES	
Materials	
Lin. Ft.	
Style	

HANDRAIL	
Materials	2x4 rails 4x4 posts
	2x6 top cap 2x2 6" O.C.
Style	#1 90 linear ft.
	1310 ⁰⁰

FENCE	

PAVE STONE	

SPECIAL STRUCTURES	

INSTRUCTIONS	

FINISHED PROJECT TOTAL	
Redwood	_____
Cedar	_____
Treated Southern Pine	5,210 ⁰⁰
Other	_____

WHEELCHAIR RAMP

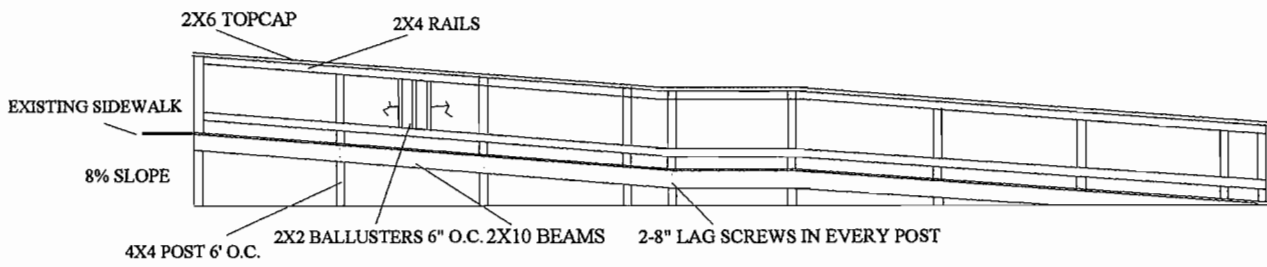

DRAWN BY: J.D.RENFRO
SCALE: 1/8"=1'
DATE: 04/23/03

City of Addison

All Seasons Deck
9647 Sunset dr.
Lavon, Tx 75166

*Deck shall have
10' min clear
walkway*

RAMP
Configuration of substructure

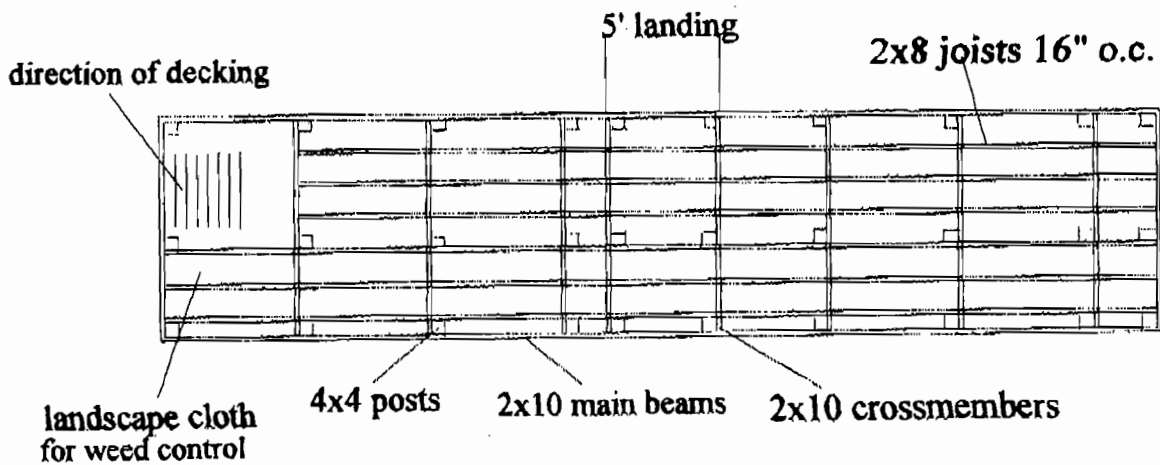

DRAWN BY: J.D. RENFRO
SCALE: 1/8"=1'
DATE: 04/24/03

ACORD CERTIFICATE OF LIABILITY INSURANCE

DATE (MM/DD/YY)
04/30/03

PRODUCER
TIM BROOKS
2602 RIDGE ROAD STE 1
ROCKWALL, TEXAS 75087
972-771-1999

THIS CERTIFICATE IS ISSUED AS A MATTER OF INFORMATION ONLY AND CONFERS NO RIGHTS UPON THE CERTIFICATE HOLDER. THIS CERTIFICATE DOES NOT AMEND, EXTEND OR ALTER THE COVERAGE AFFORDED BY THE POLICIES BELOW.

INSURERS AFFORDING COVERAGE

INSURED
ALL SEASONS DECK
9647 SUNSET DRIVE
LAVON, TEXAS 75166-1608

INSURER A: COLONY GROUP
INSURER B:
INSURER C:
INSURER D:
INSURER E:

COVERAGES

THE POLICIES OF INSURANCE LISTED BELOW HAVE BEEN ISSUED TO THE INSURED NAMED ABOVE FOR THE POLICY PERIOD INDICATED. NOTWITHSTANDING ANY REQUIREMENT, TERM OR CONDITION OF ANY CONTRACT OR OTHER DOCUMENT WITH RESPECT TO WHICH THIS CERTIFICATE MAY BE ISSUED OR MAY PERTAIN, THE INSURANCE AFFORDED BY THE POLICIES DESCRIBED HEREIN IS SUBJECT TO ALL THE TERMS, EXCLUSIONS AND CONDITIONS OF SUCH POLICIES. AGGREGATE LIMITS SHOWN MAY HAVE BEEN REDUCED BY PAID CLAIMS.

INBR LTR	TYPE OF INSURANCE	POLICY NUMBER	POLICY EFFECTIVE DATE (MM/DD/YY)	POLICY EXPIRATION DATE (MM/DD/YY)	LIMITS
A	GENERAL LIABILITY <input checked="" type="checkbox"/> COMMERCIAL GENERAL LIABILITY CLAIMS MADE <input checked="" type="checkbox"/> OCCUR	BINDER	04/30/03	04/30/04	EACH OCCURRENCE \$ 1,000,000
	GEN'L AGGREGATE LIMIT APPLIES PER: <input type="checkbox"/> POLICY <input type="checkbox"/> PROJECT <input type="checkbox"/> LOC				FIRE DAMAGE (Any one file) \$ 100,000 MED EXP (Any one person) \$ 5,000 PERSONAL & ADV INJURY \$ 1,000,000 GENERAL AGGREGATE \$ 2,000,000 PRODUCTS - COM/POP AGG \$ 2,000,000
	AUTOMOBILE LIABILITY ANY AUTO ALL OWNED AUTOS SCHEDULED AUTOS HIRED AUTOS NON-OWNED AUTOS				COMBINED SINGLE LIMIT (Ea accident) \$ BODILY INJURY (Per person) \$ BODILY INJURY (Per accident) \$ PROPERTY DAMAGE (Per accident) \$
	GARAGE LIABILITY ANY AUTO				AUTO ONLY - EA ACCIDENT \$ OTHER THAN AUTO ONLY: EA ACC \$ AGG \$
	EXCESS LIABILITY OCCUR <input type="checkbox"/> CLAIMS MADE <input type="checkbox"/> DEDUCTIBLE RETENTION \$				EACH OCCURRENCE \$ AGGREGATE \$ \$ \$ \$
	WORKERS COMPENSATION AND EMPLOYERS' LIABILITY				WC STATL TD BY LIMITS <input type="checkbox"/> OTH-ER <input type="checkbox"/> E.L. EACH ACCIDENT \$ E.L. DISEASE - EA EMPLOYEE \$ E.L. DISEASE - POLICY LIMIT \$
	OTHER				

DESCRIPTION OF OPERATIONS/LOCATION/S/VEHICLES/EXCLUSIONS ADDED BY ENDORSEMENT/SPECIAL PROVISIONS

CERTIFICATE HOLDER CITY OF ADDISON PO BOX 9010 ADDISON, TEXAS 75001	ADDITIONAL INSURED; INSURER LETTER:	CANCELLATION SHOULD ANY OF THE ABOVE DESCRIBED POLICIES BE CANCELLED BEFORE THE EXPIRATION DATE THEREOF, THE ISSUING INSURER WILL ENDEAVOR TO MAIL 10 DAYS WRITTEN NOTICE TO THE CERTIFICATE HOLDER NAMED TO THE LEFT, BUT FAILURE TO DO SO SHALL IMPOSE NO OBLIGATION OR LIABILITY OF ANY KIND UPON THE INSURER, ITS AGENTS OR REPRESENTATIVES. AUTHORIZED REPRESENTATIVE: <i>Tim Brooks</i>
-------------------------------------------------------------------------------------	--------------------------------------------	------------------------------------------------------------------------------------------------------------------------------------------------------------------------------------------------------------------------------------------------------------------------------------------------------------------------------------------------------------------------------------------------------------

ACORD 25-S (7/97)

© ACORD CORPORATION 1998

04/24/2003 13:36

972-722-1196

ALBERTSONS 4121

PAGE 01

TO: Jim Pierce

**FROM: Joey Renfro
All Seasons Deck**

SUBJECT: Bridge and Ramp

PAGES: 4

FAX #: 972 450 2837

office 972-596-9900
cell 214-683-0925

HP LaserJet 3200se



HP LASERJET 3200

APR-25-2003 1:33PM

Fax Call Report

Job	Date	Time	Type	Identification	Duration	Pages	Result
103	4/25/2003	1:31:40PM	Send	99722380344	1:48	5	OK

TOWN OF
ADDISON

PUBLIC WORKS

To: J.D. Renfro

From: Jim Pierce, P.E.
Asst. Public Wks. Dir.
Phone: 972/450-2879
FAX: 972/450-2837
jpierce@ci.addison.tx.us

Company: All Seasons Deck

FAX #: 972-238-0344

Date: 4-25-03

16801 Westgrove
P.O.Box 9010
Addison, TX 75001-9010

of pages (including cover): 5

Re: Pedestrian Ramp

Original in mail Per your request FYI Call me

Comments: Attached is a signed contract
to construct the subject ramp. I still
have not received your proof of insurance
that I must have before you begin
construction. Please fax back a
copy of the contract with your signature
and date.

Please call my office to verify receipt
of this fax.

Consider this your notice to proceed
subject to the above conditions

J. Pierce

City of Addison
Jim Pierce

All Seasons Deck

"In pursuit of perfection"

Custom Decks

Designed & Assembled

(214) 683-0925

Fax

972-238-0344

PROPOSAL

Ramp

DECK	
Materials	Treated Pine
	4600 ⁰⁰
Sq. ft.	450 45x10
Stain	yes color of choice
Skirting	
Etc.	30° slope 3 over 45' w/5' landing

ARBOR	
Materials	
Size	
Scroll	
Etc.	

BENCHES	
Materials	
Lin. Ft.	
Style	

HANDRAIL	
Materials	2x4 rails 4x4 posts
	2x6 top cap 2x2 6" O.C.
Style	#1 90 linear ft.
	1310 ⁰⁰

FENCE	

PAVE STONE	

SPECIAL STRUCTURES	

INSTRUCTIONS	

FINISHED PROJECT TOTAL	
Redwood	_____
Cedar	_____
Treated Southern Pine	5,910 ⁰⁰
Other	_____

TOWN OF
ADDISON

PUBLIC WORKS

To: J.D. Renfro

From: **Jim Pierce, P.E.**

Company: All Seasons Deck

Asst. Public Wks. Dir.

Phone: 972/450-2879

FAX #: 972-238-0344

FAX: 972/450-2837

jpierce@ci.addison.tx.us

Date: 4-25-03

16801 Westgrove

P.O.Box 9010

of pages (including cover): 5

Addison, TX 75001-9010

Re: Pedestrian Ramp

Original in mail

Per your request

FYI

Call me

Comments: Attached is a signed contract
to construct the subject ramp. I still
have not received your proof of insurance
that I must have before you begin
construction. Please fax back a
copy of the contract with your signature
and date.

Please call my office to verify receipt
of this fax.

Consider this your notice to proceed
subject to the above conditions



WHEELCHAIR RAMP

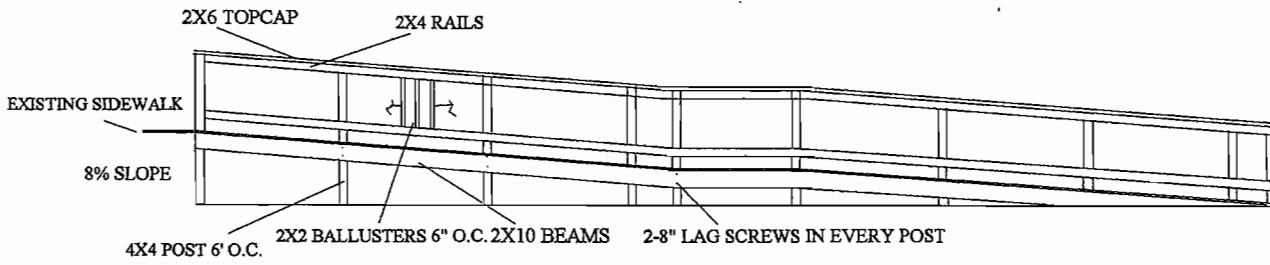

DRAWN BY: J.D. RENFRO
SCALE: 1/8"=1'
DATE: 04/23/03

City of Addison

**All Seasons Deck
9647 Sunset dr.
Lavon, Tx 75166**

RAMP
Configuration of substructure

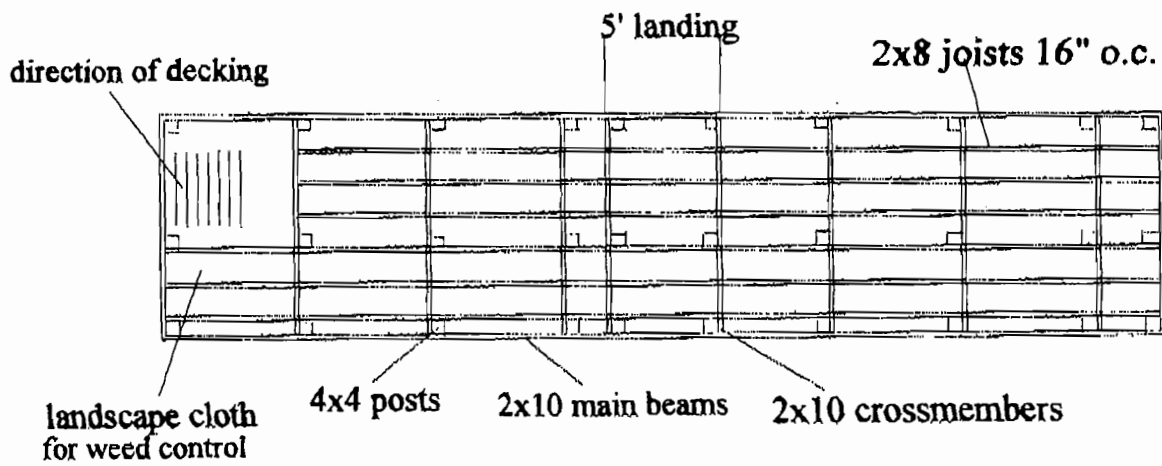

DRAWN BY: J.D. RENFRO
SCALE: 1/8"=1'
DATE: 04/24/03

Jim Pierce

From: Jim Pierce
Sent: Thursday, April 24, 2003 10:31 AM
To: Bryan Langley
Cc: Barbara Kovacevich; Jo Ann Shuffield
Subject: Taste Bridge and Ramp

Bryan: This is to justify an emergency purchase of an ADA compliant pedestrian ramp for Taste Addison. About the middle of April I was advised that if negotiations to use the Intercontinental Hotel site fell through, the Town owned property at Arapaho and Quorum would be used for the event. This would require construction of a temporary pedestrian bridge over the ditch that bisects the property. I sketched up a design and asked Jim Bowman Const. Co. to give me a quote. The quote was \$20,935. Subsequently I was asked to look for a less expensive alternative. I thought a wooden structure might work and after a search of the yellow pages, contacted Reed Fence and Deck and All Seasons Deck to discuss their capabilities. All Seasons Deck (ASD) responded immediately and I began the process of getting a design from them. (Reed Fence and Deck called about a week after my call which was too late). I received a proposal from ASD for a 6' wide bridge over the ditch. Next I was told that a ramp would be required from the sidewalk on the west side of Quorum to the site, 10' wide and ADA compliant. I asked ASD to quote on the ramp. Next I was told that the bridge should be 8' wide instead of 6' wide, and I asked for a revised quote for that. ASD responded with a quote of \$5,910 for the ramp and \$5,670 for the 8' wide bridge. Today I was advised that the bridge will not be needed but the ramp will still be needed.

All this is to show how fluid the situation has been and it would have been impossible to do all this through the normal bidding process due to lack of time.

This is to request the emergency purchase of the 10' wide ramp from All Seasons Deck for \$5,910. The contractor requires payment of 50% at the start of work and 50% at completion.

Thanks,

Jim Pierce, P.E.
Assistant Public Works Director
P.O. Box 9010
Addison, TX 75001-9010
972-450-2879

All Seasons Deck

CONTRACT

I Joseph D. Renfro, DBA All Seasons Deck, do hereby agree to build the fore mentioned project, (450 sq ft. custom ramp with 90 linear ft of custom handrail stained & sealed to color of choice ramp, and handrail material type to be treated pine) ramp and handrail to match drawing and pictures provided for a monetary sum of \$ 5, 910 of which 50% is due on the start date which is Monday, May 5 and (estimated) completion date is Friday, May 9. Total amount due upon completion of the project. Structural design and assembly of entire project to meet or surpass all engineering or architectural specifications. Main beams and cross members of substructure to be 2x10s. Span of cross members to be no more than 6 ft. Joists of substructure to be 2x8s no more than 16 inches on center. All Seasons Deck takes full liability for total completion of the project. All Seasons Deck is to provide liability insurance. In accordance with the Texas Residential Construction Liability Act, I will fulfill my obligation to repair any problems within reason that may occur within one year after the completion date.

I have read and understand the above contract.

City of Addison _____ Date _____

Contractor Joseph D. Renfro Date 4/23/03

Jim Pierce

Insurance company is drawing a new policy it will be ready later today. I will drop off a copy of insurance verification tomorrow.

Ann Wilson
All Seasons Deck

City of Addison
Jim Pierce

All Seasons Deck

"In pursuit of perfection"

Custom Decks

Designed & Assembled

(214) 683-0925

PROPOSAL

Ramp

DECK	
Materials	
Sq. ft.	4,185 ⁰⁰ 400 8x50
Stain	Yes color of choice
Skirting	No knee braces + additional cross bracing
Etc.	elevation 7' out of grade more posts

ARBOR	
Materials	
Size	
Scroll	
Etc.	

BENCHES	
Materials	
Lin. Ft.	
Style	

HANDRAIL	
Materials	Treated Pine
	100 linear ft 1485 ⁰⁰
Style	#1

FENCE	

PAVE STONE	

SPECIAL STRUCTURES	

INSTRUCTIONS	

FINISHED PROJECT TOTAL	
Redwood	_____
Cedar	_____
Treated Southern Pine	5,670 ⁰⁰
Other	_____



City of Addison
Jim Pierce

design 1

2X8 JOISTS 16" O.C.

DIRECTION OF DECKING

2X8 CROSS MEMBER

2X10 MAIN BEAMS

decking to be 5/4 treated pine

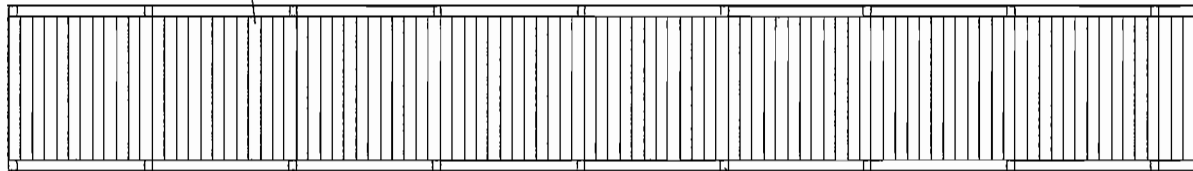

2x6 Topcap

4x4 post 6' o.c.

TYPICAL ASSEMBLY

ADDITIONAL SUPPORT

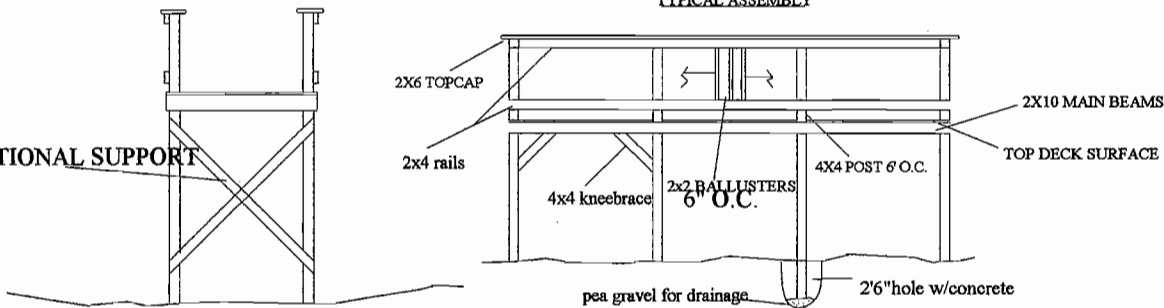

2X6 TOPCAP

2x4 rails

4x4 kneebrace

2x2 BALLUSTERS
6" O.C.

4X4 POST 6' O.C.

2X10 MAIN BEAMS

TOP DECK SURFACE

pea gravel for drainage

2'6" hole w/concrete

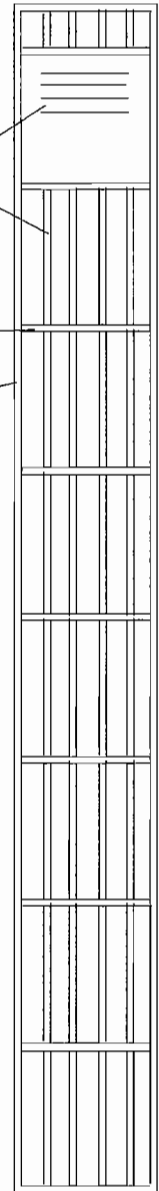

DATE:04/19/03

SCALE: 1/8" = 1'

DRAWN BY:J.D.RENFRO

All Seasons Deck

CONTRACT

I Joseph D. Renfro, DBA All Seasons Deck, do hereby agree to build the fore mentioned project, (300 sq. ft. bridge, with 100 linear ft. of custom handrail stained & sealed to color of choice deck and handrail material type to be treated pine) bridge and handrail to match drawing and pictures provided for a monetary sum of \$ 4,870 of which 50% is due on the start date which is Tuesday, April 29 and (estimated) completion date is Saturday May 3. Total amount due upon completion of the project. Structural design and assembly of entire project to meet or surpass all engineering or architectural specifications. Main beams and cross members of substructure to be 2x10s. Span of cross members to be no more than 6 ft. Joists of substructure to be 2x8s no more than 16 inches on center. All Seasons Deck takes full liability for total completion of the project. All Seasons Deck is to provide liability insurance. In accordance with the Texas Residential Construction Liability Act, I will fulfill my obligation to repair any problems within reason that may occur within one year after the completion date.

I have read and understand the above contract.

City of Addison _____ Date _____

Contractor JD Renfro _____ Date 4/23/03 _____

Edge of
Sidewalk

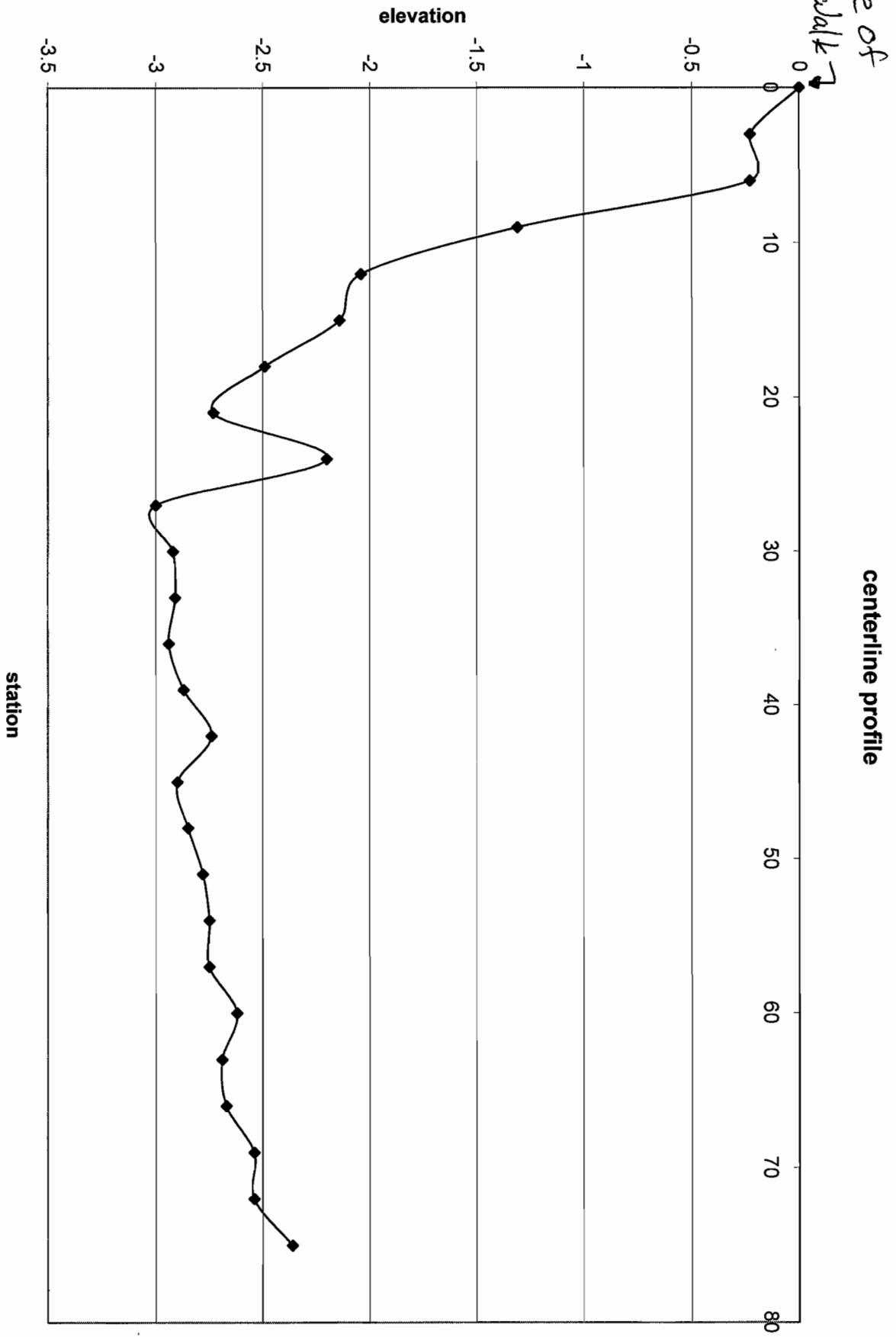

Barbara 6224

~~Reed Fence & Deck~~

~~972-422-0374~~

~~call working~~

All Seasons Deck

214-683-0925

call working

972-596-9900 office

Joey Renfro

9647 Sunset Drive, Lorton

\$ 4,000 + 350 stain

2x2 6

120 references

5 1/2 years

insured

3-5 day
to const

Max Slope 8.33%

Max cross Slope 2%

Max Rise = 30"

∴ Max Run = 30'

Landing - as wide as the ramp

min length 5'

If Landing change direction 5x5 min

Robin - will clean out ditch

*Jim Preece
City of Alderson*

All Seasons Deck

May 17, 18

"In pursuit of perfection"

Custom Decks

Designed & Assembled

(214) 683-0925

PROPOSAL

DECK	
Materials	<i>Treated Pine</i>
Sq. ft.	<i>300 6x50</i>
Stain	<i>yes 3,000⁰⁰</i>
Skirting	<i>No - Knee Braces only</i>
Etc.	<i>Elevation - roughly 7' off grade</i>

ARBOR	
Materials	
Size	
Scroll	
Etc.	

BENCHES	
Materials	
Lin. Ft.	
Style	

HANDRAIL	
Materials	<i>Treated Pine</i>
	<i>100 linear ft. 1,485⁰⁰</i>
Style	<i>#1 2-2x4 rails on edge</i>
	<i>w/ 2x2s (3" on center and 2x6 tops)</i>

FENCE	

PAVE STONE	

SPECIAL STRUCTURES	
	<i>stain & seal entire structure</i>
	<i>385⁰⁰</i>

INSTRUCTIONS	
	<i>Contract to be provided</i>
	<i>before beginning job</i>
	<i>est. start date - 04/28/03</i>
	<i>est. completion date - 05/03/03</i>

FINISHED PROJECT TOTAL	
	<i>04/20/03 JDP</i>
Redwood	_____
Cedar	_____
Treated Southern Pine	<i>4,870⁰⁰</i>
Other	_____

Joey

To: Jim Pierce
From: JD Renfro
All Seasons Deck

City of Addison
Jim Pierce

6 AM - 7 AM
May 10 & 11th
my new house

design 1

cross bracing
either side of ditch

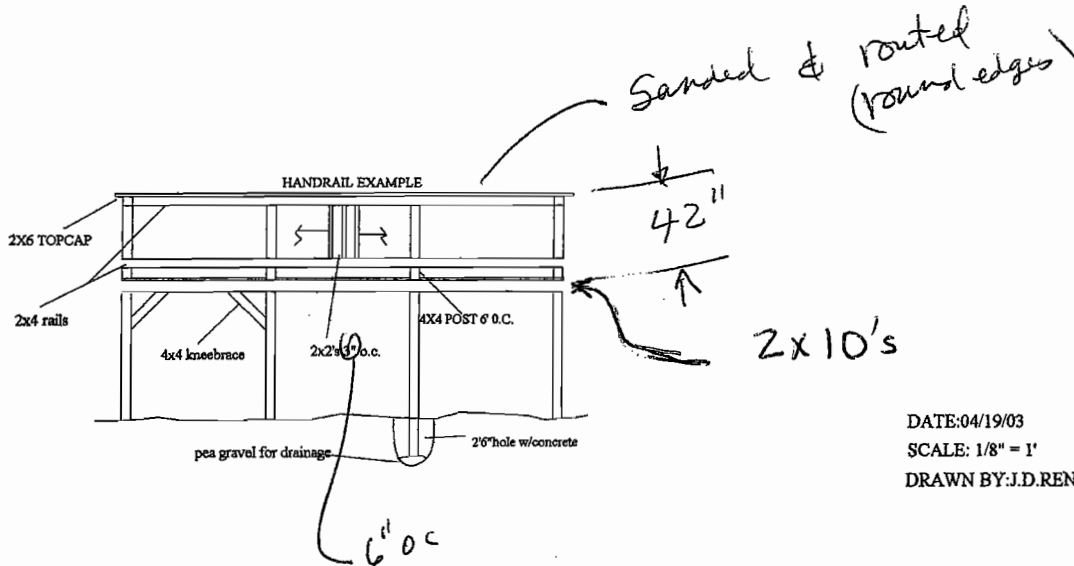
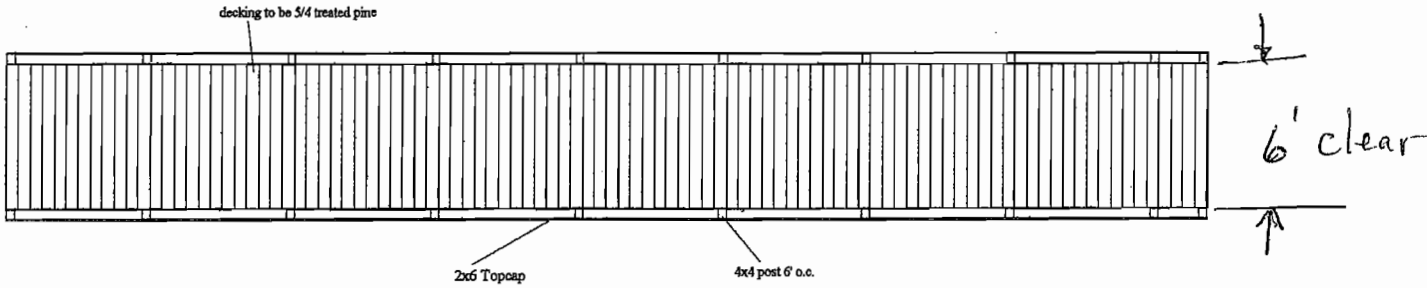

DATE: 04/19/03
SCALE: 1/8" = 1'
DRAWN BY: J.D. RENFRO

City of Addison
Jim Pierce

design 1

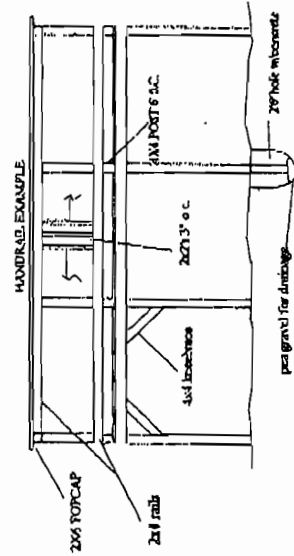
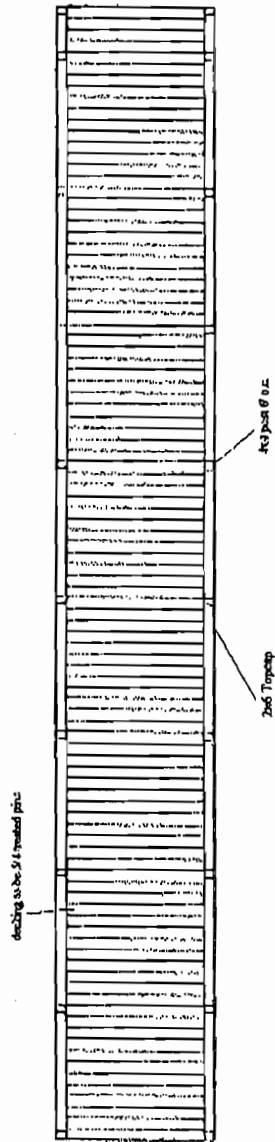

DATE: 04/19/03
SCALE: 1/8" = 1'
DRAWN BY: J.D. RENFRO

8% slope = 8'/100'
 $\frac{8}{100} = \frac{x}{30}$ x = 2.4'

RAMP - West Side Quorum Drive
 North of Railroad to Event Site

centerline profile
 ADA Compliant 10' wide Length 45' ±

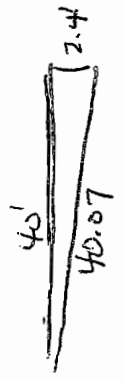
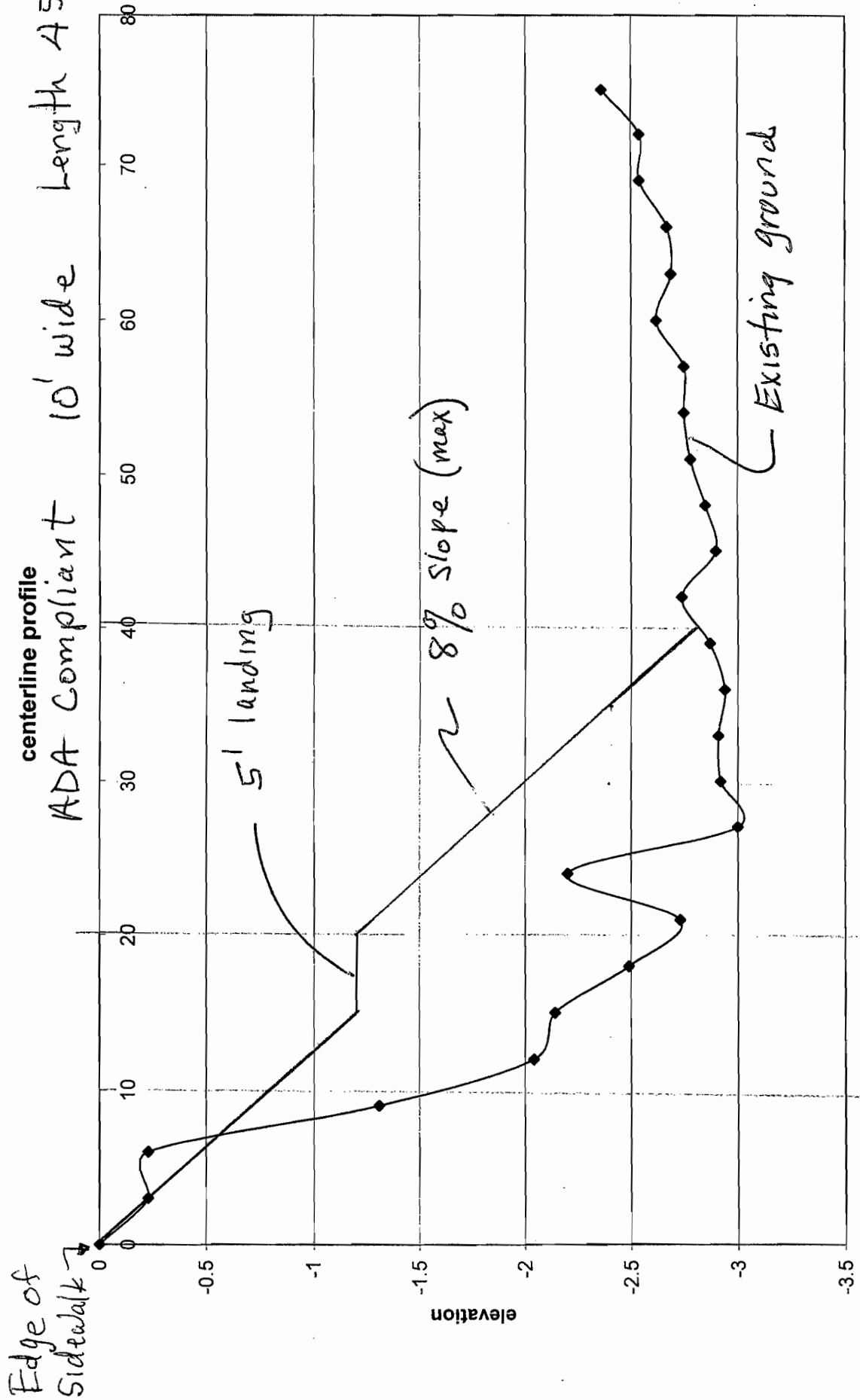

4-21-03

PROFILE

station

Jim Preece
City of Addison

All Seasons Deck

"In pursuit of perfection"

Custom Decks

Designed & Assembled

(214) 683-0925

PROPOSAL

DECK	
Materials	<i>Treated Pine</i>
Sq. ft.	<i>300 6x50</i>
Stain	<i>yes 3,000⁰⁰</i>
Skirting	<i>No - Knee Braces only</i>
Etc.	<i>Elevation - roughly 7' off grade</i>

ARBOR	
Materials	
Size	
Scroll	
Etc.	

BENCHES	
Materials	
Lin. Ft.	
Style	

HANDRAIL	
Materials	<i>Treated Pine</i>
	<i>100 linear ft. 1,485⁰⁰</i>
Style	<i>#1 2-2x4 rails on edge</i>
	<i>w/ 2x2 @ 3" on center and 2x6 top cap</i>

FENCE	

PAVE STONE	

SPECIAL STRUCTURES	
	<i>stain & seal entire structure</i>
	<i>385⁰⁰</i>

INSTRUCTIONS	
	<i>Contract to be provided</i>
	<i>before beginning job</i>
	<i>est. start date - 04/28/03</i>
	<i>est. completion date - 05/03/03</i>

FINISHED PROJECT TOTAL	
	<i>04/20/03 ADP</i>
Redwood	_____
Cedar	_____
Treated Southern Pine	<i>4,870⁰⁰</i>
Other	_____

To: Jim Pierce
From: JD Renfro
All Seasons Deck

City of Addison
Jim Pierce

6 AM - 7 AM
May 10 & 11
my new house

design 1

Cross bracing
either side of ditch

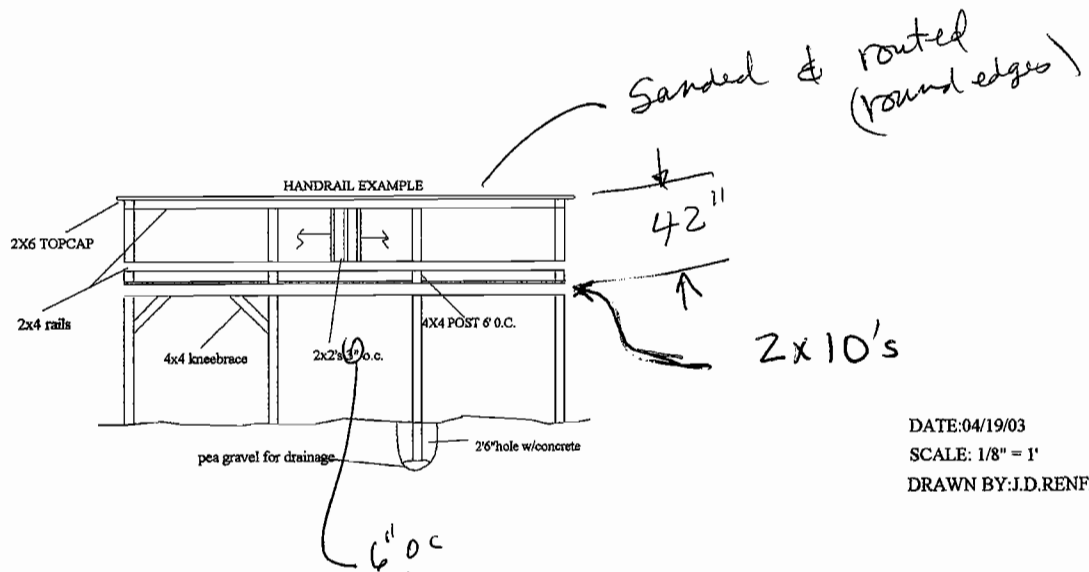
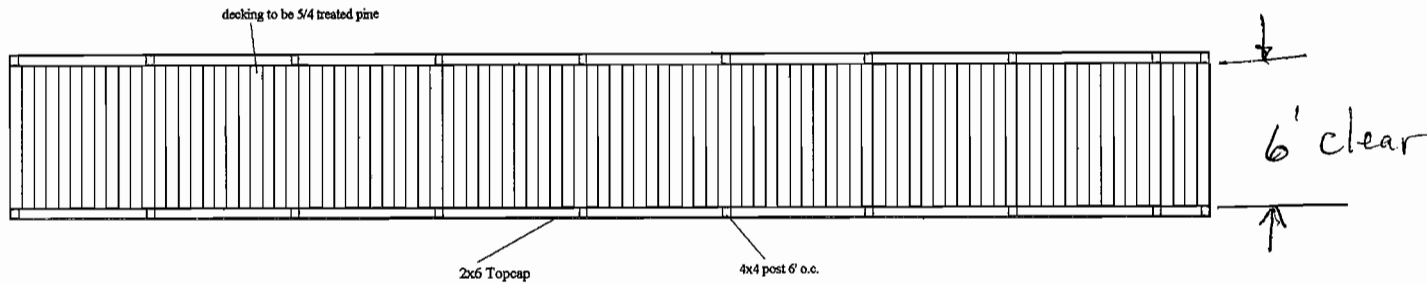

DATE: 04/19/03
SCALE: 1/8" = 1'
DRAWN BY: J.D. RENFRO

City of Addison
 Jim Pierce

design 1

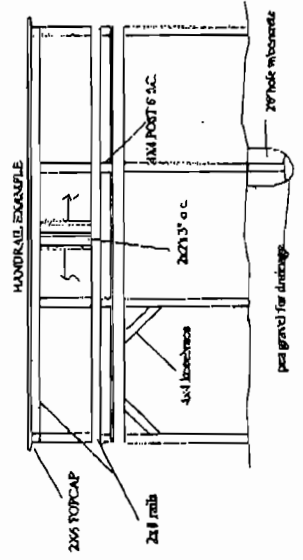
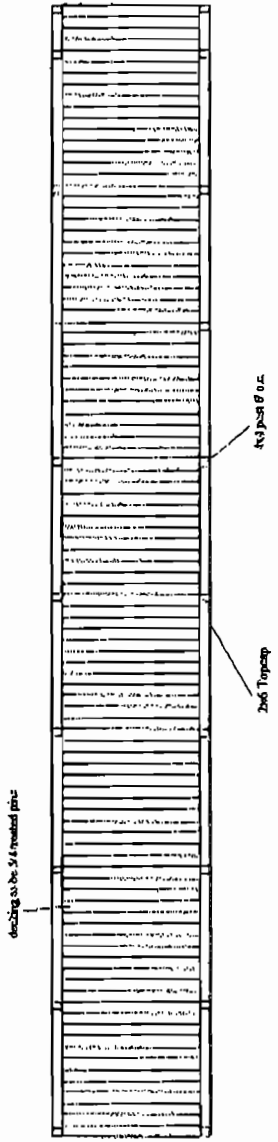

DATE: 04/19/03
 SCALE: 1/8" = 1'
 DRAWN BY: J.D. RENFRO

RAMP - West Side Quorum Drive
 North of Railroad to Event Site

8% slope = 8'/100'
 $\frac{8}{100} = \frac{x}{30}$ x = 2.4'

Edge of
 Sidewalk

centerline profile
 ADA Compliant 10' wide Length 45' ±

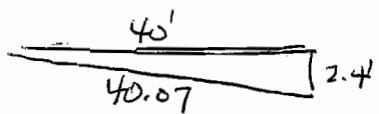
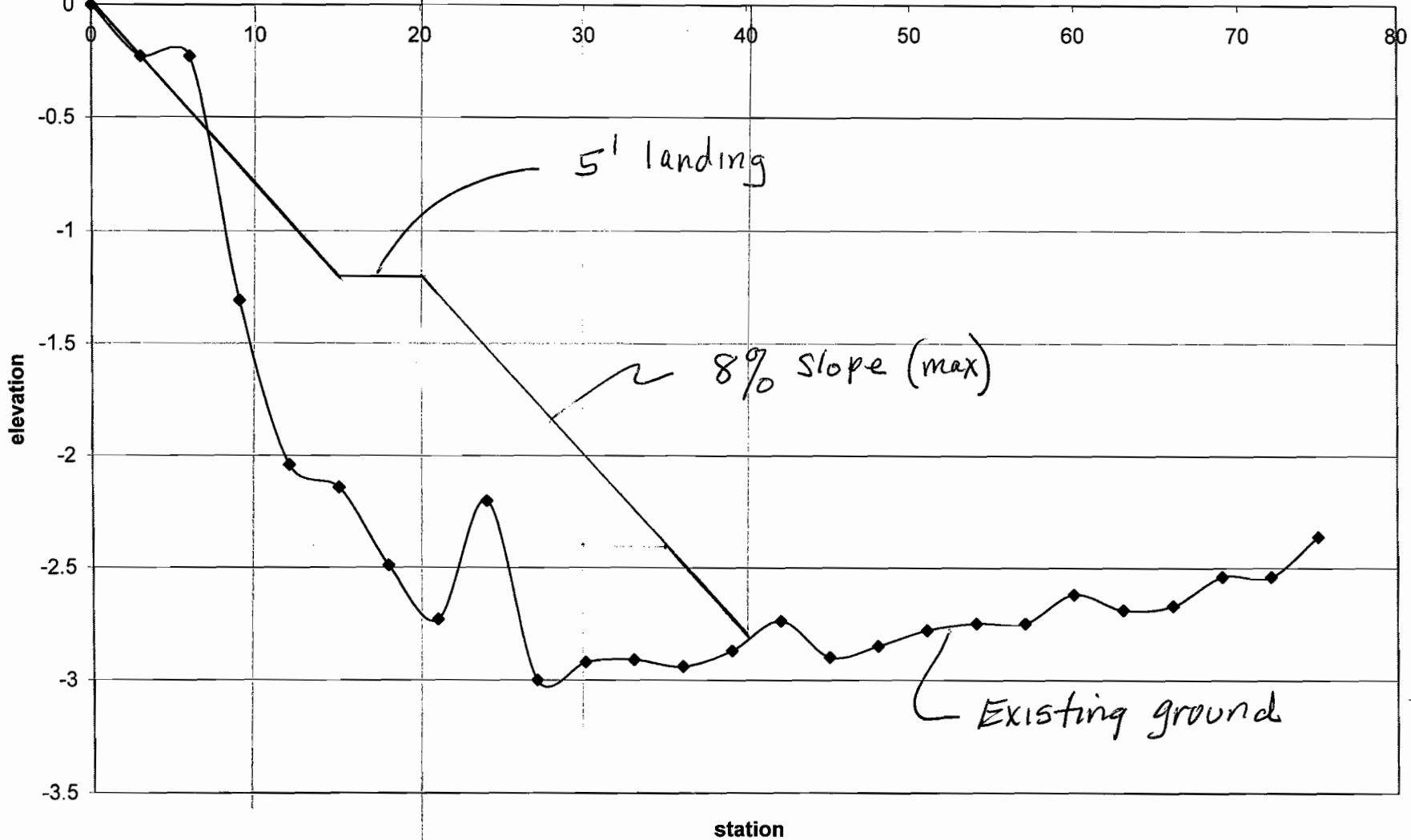

PROFILE

4-21-03

JIM BOWMAN CONSTRUCTION COMPANY, L.P.

1111 Summit Ave., Suite I

Plano, Texas 75074

(972) 423-1313

April 16, 2003

Town of Addison
16801 Westgrove
P.O. Box 9010
Addison, Texas 75001-9010

Attn: Mr. Jim Pierce, P.E., Assistant Public Works Director

Re: Pedestrian Crossing over Ditch North of Arapaho Road Opposite Spectrum Drive

Dear Mr. Pierce:

We propose to furnish all labor, materials, and equipment necessary to construct the above referenced project for the lump sum of \$20,935.00.

Work Includes:

1. Cleaning / Excavating / Grading Channel
2. 100 L.F. 42" R.C.P.
3. Crushed Concrete Infill
4. 4" Flowable Fill Topping
5. 6" Diameter Steel Posts
6. 1/4" Cable

We estimate this work will require 10 working days to complete.

Our price includes clean up of our work area upon completion of our work.

We exclude surety bonds, materials testing, restoration of disturbed areas, and utility/irrigation repair and/or relocation.

All materials and workmanship shall be in strict accordance with Sketches dated April 14, 2003 (2 sheets).

Please call if you have any questions.

Sincerely,

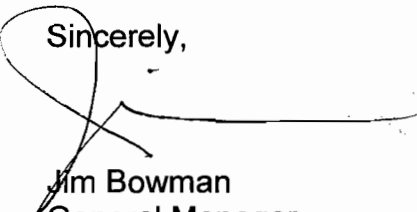

Jim Bowman
General Manager

vh

04/16/2003 15:45 9724239447

JIM BOWMAN

PAGE 02

JIM BOWMAN CONSTRUCTION COMPANY, L.P.

1111 Summit Ave., Suite 1

Plano, Texas 75074

(972) 423-1313

April 16, 2003

Town of Addison
16801 Westgrove
P.O. Box 9010
Addison, Texas 75001-9010

Attn: Mr. Jim Pierce, P.E., Assistant Public Works Director

Re: Pedestrian Crossing over Ditch North of Arapaho Road Opposite Spectrum Drive

Dear Mr. Pierce:

We propose to furnish all labor, materials, and equipment necessary to construct the above referenced project for the lump sum of \$20,935.00.

Work Includes:

1. Cleaning / Excavating / Grading Channel
2. 100 L.F. 42" R.C.P.
3. Crushed Concrete Infill
4. 4" Flowable Fill Topping
5. 6" Diameter Steel Posts
6. 1/4" Cable

We estimate this work will require 10 working days to complete.

Our price includes clean up of our work area upon completion of our work.

We exclude surety bonds, materials testing, restoration of disturbed areas, and utility/irrigation repair and/or relocation.

All materials and workmanship shall be in strict accordance with Sketches dated April 14, 2003 (2 sheets).

Please call if you have any questions.

Sincerely,



Jim Bowman
General Manager
vh

TOWN OF
ADDISON

PUBLIC WORKS

To: Jim Bowman

From: **Jim Pierce, P.E.**
Asst. Public Wks. Dir.
Phone: 972/450-2879
FAX: 972/450-2837
jpierce@ci.addison.tx.us

Company: J. Bowman Const

FAX #: 972-423-9447

Date: 4-14-03

16801 Westgrove
P.O.Box 9010
Addison, TX 75001-9010

of pages (including cover): 3

Re: Pedestrian Crossing over Ditch

- Original in mail Per your request FYI Call me

Comments: Jim: This ditch is on the North side
of Arapaho Road between Quorum & Dallas
Parkway. It is for pedestrians only. The 42"
pipe is available in Carrollton. We thought
maybe crushed concrete as fill, "capped" with
Flowable Fill to hold it and provide a walking
surface. Let me have an estimate to build
this. Your comments/ideas welcome too

Jim

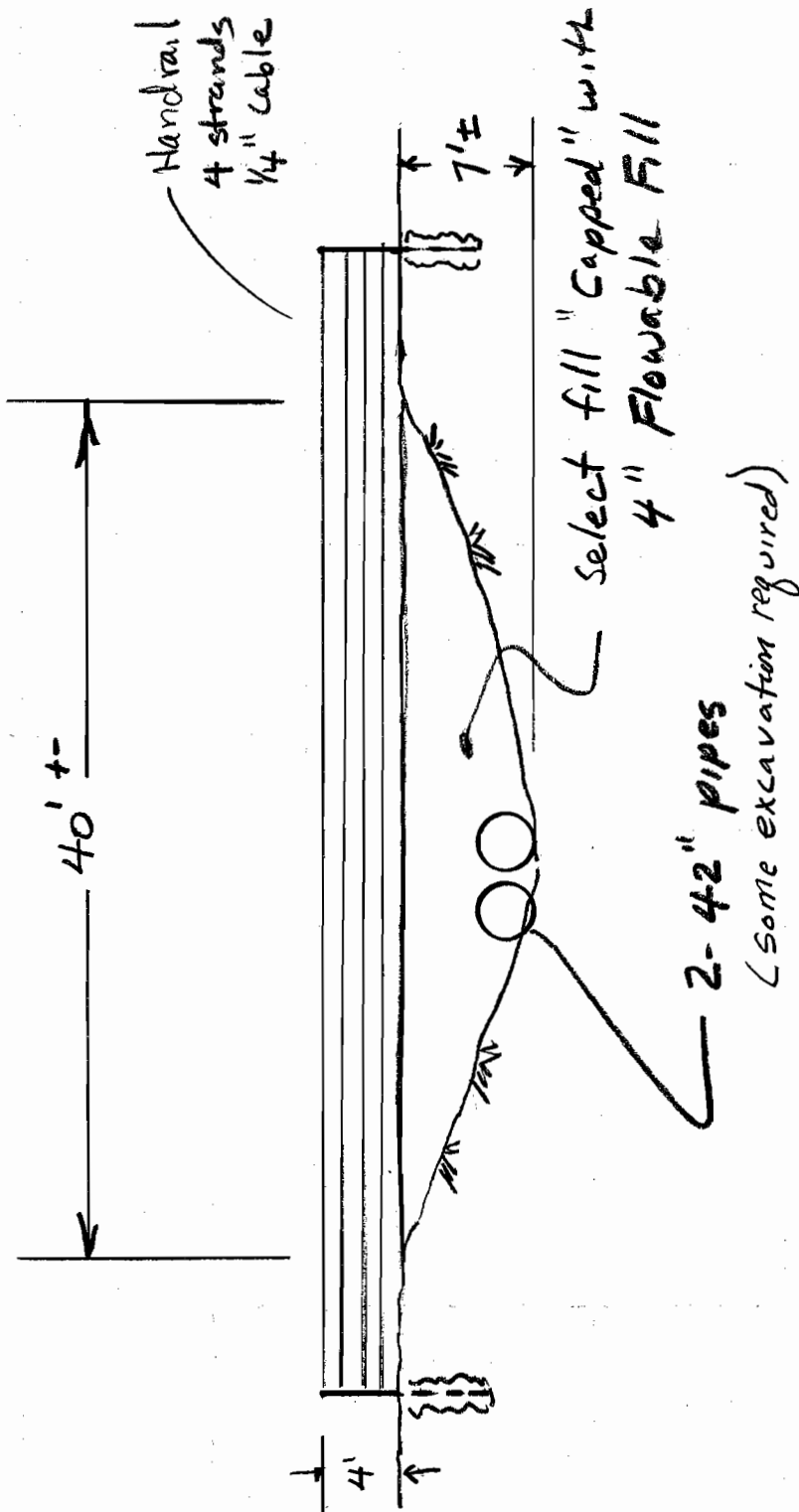

SECTION

DITCH PEDESTRIAN CROSSING

1" = 10' +/-



Craig Olden, Inc.

over 20 years

Project No.	Scale Shown	By JUP	Date 4-14-03	Page 1	of 2
-------------	----------------	-----------	-----------------	-----------	---------

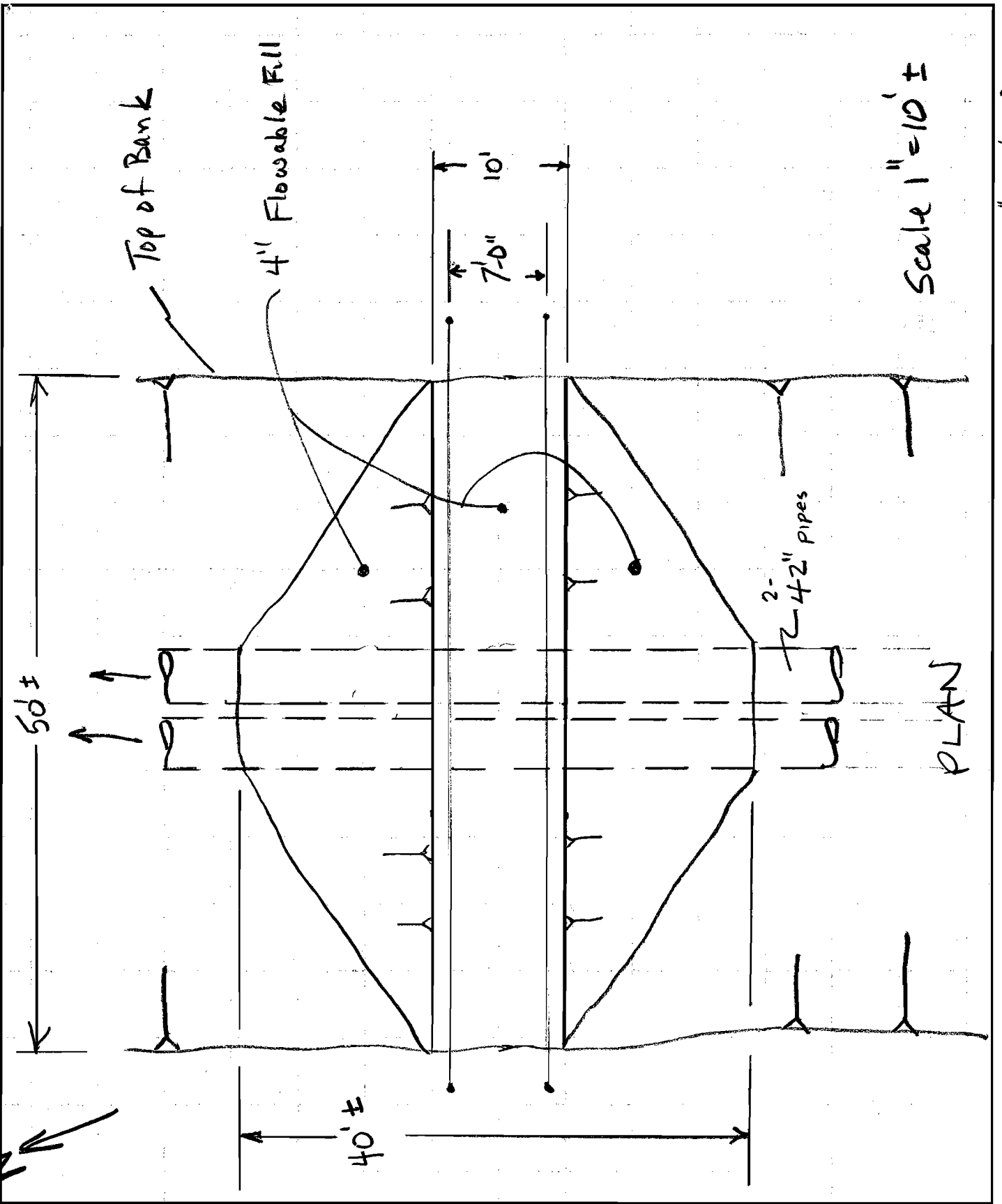

Scale 1" = 10' ±

\$10-16,000.



Craig Olden, Inc.

DITCH PEDESTRIAN CROSSING

over 20 years

Project No.	Scale shown	By JLP	Date 4-14-03	Page 2 of 2
-------------	-------------	--------	--------------	-------------



Research,
Engineering,
Design, and
Development

Call Toll Free:
1-800-648-3696

Pedestrian Bridges

*For additional information, literature or specifications,
please use this **FORM**.*

- Aluminum Construction
- Conforms to State & Federal Codes
- Smooth Continuous Handrails
- Extruded, Non-Skid Walking Surface
- Pre-Engineered
- Drawings & Engineering Calculations Available Upon Request
- Value Engineered
- Long Life Cycle for Cost Savings

▶
**Lake City Community College
uses this 6' X 43' long
pedestrian bridge for it's
students to cross a
water retention area.**

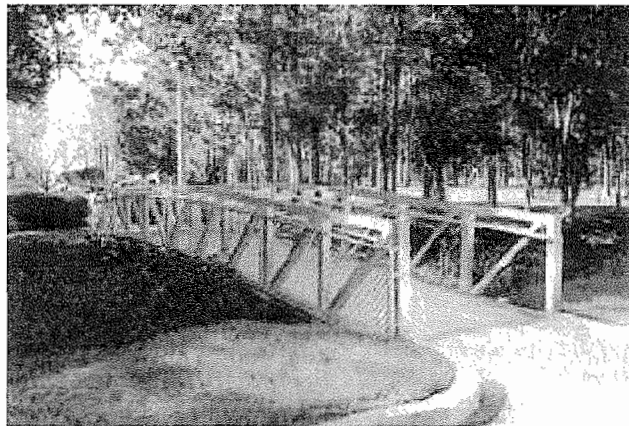

▶
**Beach Access is available to hotel guests by this 54'
long aluminum bridge.**

A 6' wide X 30' long bridge is used to span a retention basin.

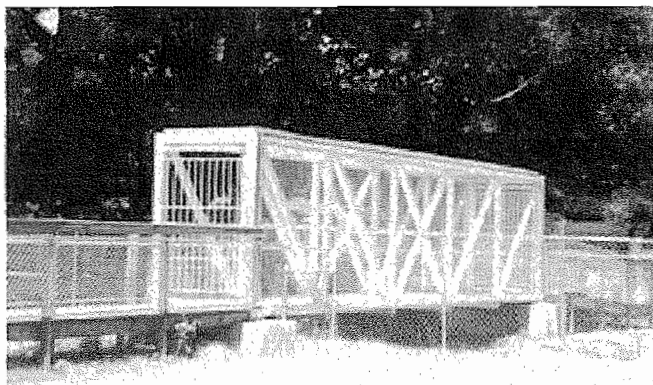

This cage bridge provides security for schools.
West Mobile, AL

Dark Green painted bridge.
N. Richland Hills, TX



Pedestrian bridge next to highway.
Volusia County, FL

So we may better serve you - please fill out our Visitor Registration Form.

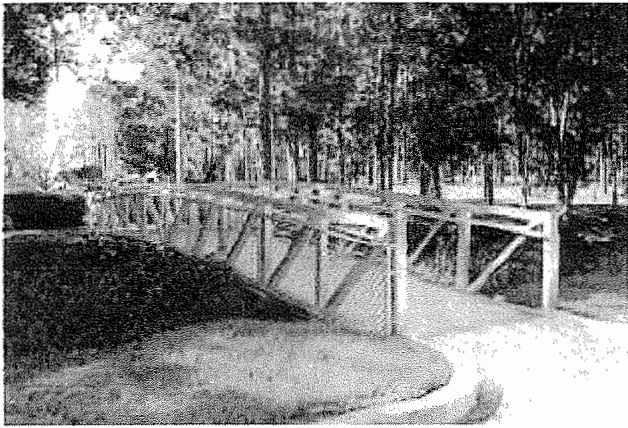

HP LaserJet 3200se



HP LASERJET 3200

APR-14-2003 4:59PM

Fax Call Report

Job	Date	Time	Type	Identification	Duration	Pages	Result
446	4/14/2003	4:56:18PM	Send	99724239447	2:44	3	OK

TOWN OF

ADDISON

PUBLIC WORKS

To: Jim Bowman

From: Jim Pierce, P.E.

Company: J. Bowman Const

Asst. Public Wks. Dir.

Phone: 972/450-2879

FAX: 972/450-2837

FAX #: 972-423-9447

jpierce@ci.addison.tx.us

Date: 4-14-03

16801 Westgrove

P.O.Box 9010

of pages (including cover): 3

Addison, TX 75001-9010

Re: Pedestrian Crossing over Ditch

Original in mail Per your request FYI Call me

Comments: Jim: This ditch is on the North side of Arapaho Road between Quorum & Dallas Parkway. It is for pedestrians only. The 42" pipe is available in Carrollton. We thought maybe crushed concrete as fill, "capped" with Flowable Fill to hold it and provide a walking surface. Let me have an estimate to build this. Your comments/ideas welcome for

Jim



"Laminated Wood Pedestrian Bridges"

"PED" MODEL BY RCP Widths: 4', 6' & 8' ♦ Spans: 20' - 120' (in 2' increments)

- I. **SCOPE:** Width will be _____. Span will be _____ and per specifications herein.
- II. **DESIGN CRITERIA:** Bridge system will be designed for a minimum of eighty-five (85) pounds per square foot (psf) live load and ten (10) pounds per square (psf) foot dead load plus stringer weight, and designed for wet use, as furnished by **RCP Shelters, Inc., 959 SE Central Parkway * Stuart, FL 34994-3904, (772) 288-3675, FAX (772) 288-3675, email: info@rcpshelters.com .**
Note: Bridge abutment to be designed and furnished by others, to stabilize the forces that occur at connections.
- III. **GLUED LAMINATED STRINGERS & DIAPHRAGM:** Will be fabricated with architectural grade southern pine and APA/EWS certified. Members will be factory pre-drilled, CCA 0.4 pcf Pressure treated to resist decay and insect infestation, sealed and individually wrapped for protection in transit.
- IV. **POST & RAILS:** All required lumber, connections and bolts for rails to be included. Rails to be glu-laminated, CCA 0.4 pcf pressure treated to resist decay and insect infestation, sealed & individually wrapped for protection in transit.
- V. **BRIDGE DECK:** shall be nominal 2", CCA treated Southern Pine, kiln dried and furnished in specified lengths (S/L).
- VI. **GALVANIZED STEEL AND HARDWARE:** All steel and hardware required for complete assembly, excluding anchor bolts, to be provided by manufacturer (RCP). All steel and hardware to be hot-dipped galvanized after fabrication for long life. Anchor bolts are not included.
- VII. **ASSEMBLY:** Bridge superstructure to be shipped unassembled. Bridges to be shipped knocked down (kd). Stringers should be unloaded with care using padded non marring slings (crane required).
- VIII. **STORAGE:** The Owner or contractor is responsible for protection of materials after arrival. If stored temporarily, block members well off the ground and separate with wood strips to allow circulation. Cover top and bottom with moisture resistant paper. Use non-marring slings when handling.

Note: technical specifications are subject to change for product improvement without notice.



Pedestrian Bridges by RCP

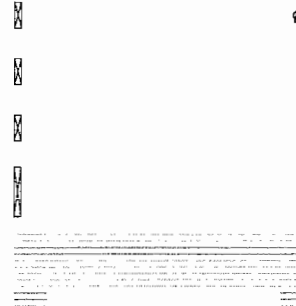
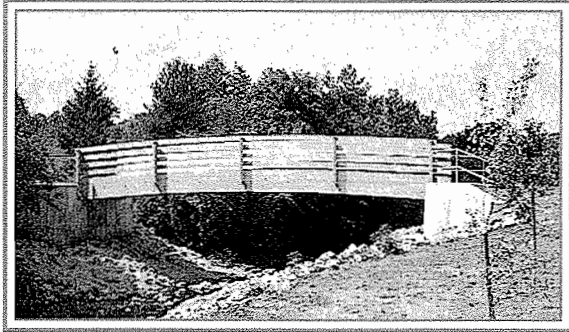

"Typical Section"

Span	Widths			Span	Widths		
	4'	6'	8'		4'	6'	8'
20'	\$8,338	\$8,635	\$8,664	52'	\$26,038	\$27,724	\$31,400
22'	\$9,650	\$9,926	\$10,709	54'	\$27,113	\$28,868	\$32,234
24'	\$10,300	\$10,787	\$11,144	56'	\$28,413	\$29,594	\$33,626
26'	\$11,125	\$11,747	\$12,415	58'	\$29,988	\$31,808	\$35,284
28'	\$11,775	\$12,398	\$13,262	60'	\$30,613	\$31,894	\$36,554
30'	\$12,275	\$13,395	\$13,879	62'	\$33,775	\$33,358	\$36,264
32'	\$13,988	\$15,289	\$16,008	64'	\$34,375	\$33,948	\$37,970
34'	\$15,600	\$16,494	\$17,061	66'	\$36,150	\$35,695	\$39,652
36'	\$16,288	\$17,195	\$17,908	68'	\$37,713	\$37,232	\$41,418
38'	\$16,838	\$17,798	\$18,779	70'	\$40,113	\$39,594	\$43,814
40'	\$17,725	\$18,696	\$19,832	72'	\$41,750	\$41,205	\$44,952
42'	\$20,025	\$21,082	\$21,889	74'	\$42,950	\$42,386	\$46,791
44'	\$21,038	\$22,079	\$23,341	76'	\$44,663	\$44,071	\$48,690
46'	\$21,563	\$23,099	\$24,333	78'	\$46,413	\$45,793	\$55,140
48'	\$22,550	\$24,133	\$25,519	80'	\$48,338	\$47,933	\$56,459
50'	\$23,950	\$25,547	\$26,814	82'	\$52,500	\$52,152	\$57,838

Custom Widths, and RCP Covered Bridges Available (nominal engineering costs may apply). Please fax (772) 288-0207 with your inquiry.

RCP Shelters, Inc. ♦ Since 1957
 959 SE Central Parkway ♦ Stuart, FL 34994-3904
 Ph: (772) 288-3675 ♦ Fax: (772) 288-0207 ♦ Copyright © 2003 - All Rights Reserved

3rd Weekend

Span Ditch -

May -
May 17 & 18

Pedestrian only

C. L. Burns - 888-576-2722

Buck Overhead - only
Don't do that.

Gateway Bridge 1-866-532-3099

Mr. Brown - Left message

REDD Team 1-800-648-3696 X 116 or
answer

Wayne Morris #

Base Price: \$ 17,625 inc. shipping
5000 pounds

Rent a Crane

6' wide

Prepare Foundation with

ADA compliant

Anchor bolts

Area 42" pipe = $9.62 \text{ ft}^2 \times 2 = 19.24 \text{ ft}^2$

Area 36" pipe = $7.07 \times 3 = 21.21$

Need an answer tomorrow 4/15

Jim Lemos, ADS

cell 214-325-6875

1-281-933-0951

Volume of Fill:

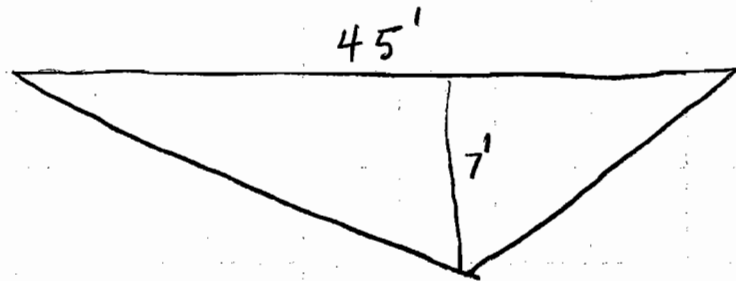

$$\text{Area} = b \times h = 45' \times 7' = 315 \text{ ft}^2$$

@ end of pipe Area = 0

$$\text{Avg area} = 157.5 \text{ ft}^2$$

$$\text{Volume} = \text{Avg Area} \times \text{Length} = 157.5 \times 18' = 2835 \text{ ft}^3$$

multiply $\times 2$ (2 sides of path) 2835 ft^3

$$\text{Volume of path} = 315 \text{ ft}^2 \times 10' =$$

$$3150 \text{ ft}^3$$

Total Volume =

$$8820 \text{ ft}^3$$

$$\approx 326 \text{ yd}^3$$

Area of Surfaces

$$\text{slopes } 18' \times 50' \times 2 = 118 \text{ ft}^2 + 20\% \text{ for slope factor} = 142 \text{ ft}^2$$

$$\text{ped. walk } 50' \times 10' = 500 \text{ ft}^2$$

$$500 \text{ ft}^2$$

$$642 \text{ ft}^2$$

$$642 \text{ ft}^2 \times \frac{4''}{12} \text{ (thickness of)} = 214 \text{ ft}^3 \text{ or } 8 \text{ yd}^3$$

(flowable)

subtract the volume of the pipes



Craig Olden, Inc.

over 20 years

Project No.	Scale	By	Date	Page	of
-------------	-------	----	------	------	----

Hasty
Cost Estimate

Len 42" 27.50/ft
36" 19.50/ft

2-42" pipes \$3,000
Install 450

326 yd³ Select fill @ 15 4890
installed

Bowman:

Fax

972 423-9447

Flowable Fill 8 yd³@ 100 800

4 Bollards @ 500 1000

Cable:
60' x 8 = 4 80' seg 500 @ 1⁰⁰ 500

\$ 10,640

X 1.5 \$ 16,000



Craig Olden, Inc.

over 20 years

Project No.	Scale	By	Date	Page of
-------------	-------	----	------	---------

ADS

Dist. Office

42"

Bell & Spigot

in stock Carrollton

\$29.40/ft

\$3000

Jim Lemos -