

5-



Street Lights

5-



No CHANGE for 5-9-97
MR-5-9-97
No FACILITIES CHANGE AT
this time - MR.

Larry A. Kramer, P.E.
Account Executive
Farmers Branch District

May 2, 1997

Mr. John Baumgartner
Town of Addison
P.O. Box 144
Addison TX 75001

Dear Mr. Baumgartner:

The Town of Addison presently has accounts on both the Municipal Service (MS) rate structure and the General Service (GS) rate structure. Accounts that are on the MS rate have the option of changing to the GS structure if you request such a change. Any new account or any account presently on the GS type of rate cannot move to the MS format.

We have performed a review of those accounts presently on the MS rate structure to determine if any may be lower when billed on the GS structure. The results of this review are attached. It should be understood that this study is an estimate of the bills and uses consumption history as the foundation for the results. Changes in consumption characteristics and rate structures may alter the results. Once an account is placed on the General Service Rate structure it cannot be moved back to the Municipal Service format.

Please review the results of this study and sign and return the first two pages of each printout to my attention. If you find any accounts you would like to move to the General Service rate, please indicate so on the second pages as noted.

If you have any questions, please do not hesitate to contact me at 972/888-1309.

Sincerely,

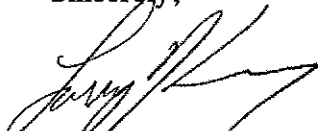

Larry Kramer

RATE APPLICATION REVIEW

TOWN OF ADDISON

PROCESS DATE: 04/28/97

THIS IS TO CERTIFY THAT THE ELECTRIC SERVICE
ACCOUNTS FOR TOWN OF ADDISON
WERE REVIEWED FOR PROPER RATE APPLICATION.

RATE CHANGES REQUESTED ARE LISTED BY PREMISE
NUMBER ON THE ATTACHED SHEETS.

CUSTOMER

TU ELECTRIC

BY

BY

TITLE

TITLE

DATE

DATE

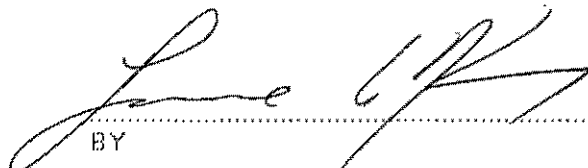

Account Executive

May 1, 1997

ELECTRIC RATE APPLICATION SUMMARY
 FOR THE: TOWN OF ADDISON

PROCESS DATE: 04/28/97

SUMMARY ACCOUNT: 273-5969-99

	PREMISE NUMBER	TENN	LOCATION	CURRENT RATE	CHANGE RATE TO :
1)	107-0246-99		TOWN OF ADDISON 14924 MIDWAY RD	540
2)	116-0518-99		TOWN OF ADDISON 05003 ARAPAHO RD	540
3)	116-1510-99		TOWN OF ADDISON 05000 BELT LINE RD	540
4)	116-7927-99		TOWN OF ADDISON 05300 BELT LINE RD	540
5)	116-9043-98		TOWN OF ADDISON 14955 OAKS NORTH DR	540
6)	117-2608-99		TOWN OF ADDISON 05350 BELT LINE RD	540
7)	131-9889-99		TOWN OF ADDISON 04569 BELT LINE RD	540
8)	131-9982-99		TOWN OF ADDISON 04299 BELT LINE RD	540
9)	132-0571-99		TOWN OF ADDISON 00000 @MIDWAY & LIN	540
10)	133-3002-99		TOWN OF ADDISON 15348 ADDISON RD	540
11)	133-3932-99		TOWN OF ADDISON 00000 @ADDISON THEA	540
12)	133-4366-99		TOWN OF ADDISON 15892 ADDISON RD	540
13)	133-5048-99		TOWN OF ADDISON 04953 AIRPORT PKY	540
14)	133-6164-99		TOWN OF ADDISON 05001 KELLER SPRING RD	540
15)	133-8210-99		TOWN OF ADDISON 00000 @SOJOURN & AD	540
16)	134-1744-99		TOWN OF ADDISON 00000 @WESTGROVE &	540
17)	134-1961-99		TOWN OF ADDISON 05024 WESTGROVE DR	540
18)	134-4720-99		TOWN OF ADDISON 00000 @KELLER SPRIN	540

ELECTRIC RATE APPLICATION SUMMARY
 FOR THE: TOWN OF ADDISON

PROCESS DATE: 04/28/97

SUMMARY ACCOUNT: 273-5969-99

	PREMISE NUMBER	TENN	LOCATION	CURRENT RATE	CHANGE RATE TO :
19)	134-7076-99		TOWN OF ADDISON 04665 BELT LINE RD	540
20)	195-0832-99		TOWN OF ADDISON 03881 BELT LINE RD	540
21)	263-9404-99		TOWN OF ADDISON 04008 DOME RD	540
22)	264-1853-99		TOWN OF ADDISON 03960 BELTWAY DR	540
23)	264-3279-99		TOWN OF ADDISON 03950 BELTWAY DR	540
24)	264-8425-99		TOWN OF ADDISON 04000 BELT LINE RD	540
25)	270-9960-99		TOWN OF ADDISON 03901 SPRING VALLEY RD	540
26)	271-0115-99		TOWN OF ADDISON 00000 QS SIDNEY RD	540
27)	272-1151-99		TOWN OF ADDISON 03800 SPRING VALLEY RD	540
28)	605-2070-99		TOWN OF ADDISON 05081 BELT LINE RD	540
29)	605-2132-99		TOWN OF ADDISON 15581 DALLAS PKY	540
30)	605-4705-99		TOWN OF ADDISON 05090 BELT LINE RD	540
31)	613-1926-99		TOWN OF ADDISON 05430 CELESTIAL RD	540
32)	613-4995-99		TOWN OF ADDISON 05081 WESTGROVE DR	540
33)	616-8785-99		TOWN OF ADDISON 05300 CELESTIAL RD	540
34)	625-4252-99		TOWN OF ADDISON 16201 QUORUM DR	540
35)	635-5002-99		TOWN OF ADDISON 14707 SHERLDCK DR	540
36)	704-0691-99		TOWN OF ADDISON 04078 BELT LINE RD	540

SUMMARY ACCOUNT: 273-5969-99

ACCOUNT NUM: 107-0246-99

14924.MIDWAY

CITY OF: TOWN OF ADDISON

INDUSTRIAL CODE: 09826

REVENUE CODE: 03

BILLING RATE: 540 - MISCELLANEOUS MUNICIPAL SERVICE

COMPARISON OF TU ELECTRIC BILLING RATES

HISTORICAL					ALTERNATE RATES			
	KWH	ACTUAL	BILL	MS	BILL	GS	BILL	
	*****	KW	KW	540	KW	200	KW	***
	*****	*****	****	***	*****	***	****	***
PR	1.326	0	0	111.95	10	121.43	0	0.00
AR	1.411	0	0	118.18	10	128.32	0	0.00
EB	1.403	0	0	117.59	10	127.68	0	0.00
AN	1.624	0	0	133.75	10	145.58	0	0.00
EC	1.541	0	0	127.35	10	138.64	0	0.00
DV	1.485	0	0	123.35	10	134.15	0	0.00
CT	1.575	0	0	155.26	10	141.32	0	0.00
EP	1.806	0	0	176.32	10	160.33	0	0.00
JG	1.604	0	0	158.29	10	143.98	0	0.00
LY	1.674	0	0	164.28	10	149.50	0	0.00
JN	1.947	0	0	188.61	10	171.57	0	0.00
AY	1.520	0	0	125.89	10	136.98	0	0.00
LARGEST KW		0 TOTALS		1.700.82	1.699.48			

SUMMARY ACCOUNT: 273-5969-99

ACCOUNT NUM: 116-0518-99 5003,ARAPAHO.ESIGNAL
 CITY OF: TOWN OF ADDISON INDUSTRIAL CODE: 09826
 REVENUE CODE: 03
 BILLING RATE: 540 - MISCELLANEOUS MUNICIPAL SERVICE

COMPARISON OF TU ELECTRIC BILLING RATES

HISTORICAL					ALTERNATE RATES			
	KWH	ACTUAL KW	BILL KW	MS 540	BILL KW	GS 200	BILL KW	
***	*****	*****	****	***	****	***	****	***
PR	1.366	0	0	114.87	10	124.67	0	0.00
NR	1.346	0	0	113.42	10	123.06	0	0.00
EB	1.228	0	0	104.80	10	113.50	0	0.00
AN	1.569	0	0	129.72	10	141.11	0	0.00
EC	1.414	0	0	118.10	10	128.37	0	0.00
IV	1.316	0	0	111.02	10	120.47	0	0.00
YT	1.195	0	0	121.43	10	110.60	0	0.00
EP	1.211	0	0	123.17	10	112.12	0	0.00
JB	1.293	0	0	130.51	10	118.78	0	0.00
LY	1.335	0	0	134.05	10	122.06	0	0.00
JN	1.409	0	0	140.63	10	128.03	0	0.00
Y	1.307	0	0	110.35	10	119.75	0	0.00
LARGEST KW		0	TOTALS	1.452.07	1.462.52			

SUMMARY ACCOUNT: 273-5969-99

ACCOUNT NUM: 116-1510-99 5000,BELTLINE
 CITY OF: TOWN OF ADDISON INDUSTRIAL CODE: 09826
 REVENUE CODE: 03
 BILLING RATE: 540 - MISCELLANEOUS MUNICIPAL SERVICE

COMPARISON OF TU ELECTRIC BILLING RATES

HISTORICAL					ALTERNATE RATES			
	KWH	ACTUAL	BILL	MS	BILL	GS	BILL	
		KW	KW	540	KW	200	KW	
	*****	*****	*****	***	*****	***	*****	***
EV	1.972	0	0	159.17	10	173.76	0	0.00
J	1.886	0	0	152.91	10	166.81	0	0.00
**	1.768	0	0	144.28	10	157.25	0	0.00
PR	2.006	0	0	161.69	10	176.53	0	0.00
AR	1.827	0	0	148.21	10	161.78	0	0.00
EB	1.933	0	0	156.03	10	170.39	0	0.00
AN	1.879	0	0	182.33	10	165.89	0	0.00
EC	1.858	0	0	180.96	10	164.54	0	0.00
DU	1.904	0	0	185.10	10	168.29	0	0.00
CT	1.935	0	0	187.56	10	170.62	0	0.00
EP	2.069	0	0	199.49	10	181.44	0	0.00
JG	1.898	0	0	153.46	10	167.57	0	0.00
LY								
JN								
AY								
LARGEST KW		0	TOTALS	2,011.19		2,024.87		

SUMMARY ACCOUNT: 273-5969-99

ACCOUNT NUM: 116-7927-99 5300,BELTLINE
 CITY OF: TOWN OF ADDISON INDUSTRIAL CODE: 09827
 REVENUE CODE: 04
 BILLING RATE: 540 - MISCELLANEOUS MUNICIPAL SERVICE

COMPARISON OF TU ELECTRIC BILLING RATES

HISTORICAL					ALTERNATE RATES			
	KWH	ACTUAL KW	BILL KW	MS 540	BILL KW	GS 200	BILL KW	
**	*****	*****	****	***	****	***	****	***
PR	8.220	31	0	615.98	38	744.32	0	0.00
SR	8.580	37	0	642.41	38	762.72	0	0.00
EB	7.020	34	0	528.32	38	683.27	0	0.00
AN	7.560	34	0	567.78	38	710.75	0	0.00
EC	7.380	31	0	553.10	38	700.57	0	0.00
IV	8.700	33	0	649.76	38	767.81	0	0.00
BT	11.640	37	0	1,051.62	38	894.54	0	0.00
EP	14.040	43	0	1,269.13	43	1,022.75	0	0.00
IG	16.980	43	0	1,531.90	43	1,099.64	0	0.00
LY	19.200	47	0	1,727.24	47	1,206.63	0	0.00
JN	16.980	45	0	1,529.03	45	1,123.23	0	0.00
Y	11.700	47	0	868.53	47	996.28	0	0.00
-----					-----			
LARGEST KW		47	TOTALS	11,534.80		10,712.51		

SUMMARY ACCOUNT: 273-5969-99

ACCOUNT NUM: 116-9043-98

UNCERTIAN

CITY OF: TOWN OF ADDISON

INDUSTRIAL CODE: 09827

REVENUE CODE: 04

BILLING RATE: 540 - MISCELLANEOUS MUNICIPAL SERVICE

COMPARISON OF TU ELECTRIC BILLING RATES

HISTORICAL					ALTERNATE RATES			
	KWH	ACTUAL KW	BILL KW	MS 540 ***	BILL KW	GS 200 ***	BILL KW	***
*****	*****	*****	*****	***	*****	***	*****	***
PR	357	2	0	41.11	10	42.93	0	0.00
AR	360	2	0	41.32	10	43.17	0	0.00
EB	364	3	0	43.08	10	45.12	0	0.00
AN	1,005	7	0	88.48	10	95.43	0	0.00
EC	729	7	0	68.15	10	72.97	0	0.00
IV	570	3	0	56.59	10	60.12	0	0.00
CT	426	3	0	52.93	10	48.43	0	0.00
EP	168	3	0	30.01	10	27.61	0	0.00
JG	516	3	0	61.10	10	55.81	0	0.00
LY	360	3	0	47.10	10	43.14	0	0.00
JN	483	3	0	58.06	10	53.08	0	0.00
AY	729	3	0	68.18	10	72.99	0	0.00
-----				-----				
LARGEST KW		7	TOTALS	656.11		660.80		

SUMMARY ACCOUNT: 273-5969-99

ACCOUNT NUM: 117-2608-99 5350,BELTLINE
 CITY OF: TOWN OF ADDISON INDUSTRIAL CODE: 09827
 REVENUE CODE: 04
 BILLING RATE: 540 - MISCELLANEOUS MUNICIPAL SERVICE

COMPARISON OF TU ELECTRIC BILLING RATES

HISTORICAL					ALTERNATE RATES			
	KWH	ACTUAL	BILL	MS	BILL	GS	BILL	
	*****	*****	*****	540	KW	200	KW	*****
	*****	*****	*****	***	*****	***	*****	***
PR	7.980	34	0	598.45	40	749.01	0	0.00
AR	7.860	33	0	589.75	40	742.95	0	0.00
EB	9.000	35	0	673.10	40	800.99	0	0.00
AN	9.600	37	0	716.95	40	831.53	0	0.00
EC	9.120	40	0	679.97	40	805.84	0	0.00
IV	9.780	40	0	728.56	40	839.59	0	0.00
DT	11.100	44	0	1,003.52	44	939.65	0	0.00
EP	11.860	48	0	1,076.18	48	1,015.25	0	0.00
IG	12.780	48	0	1,156.70	48	1,053.21	0	0.00
LY	13.860	50	0	1,251.01	50	1,105.55	0	0.00
JN	13.320	48	0	1,202.69	48	1,065.95	0	0.00
Y	10.740	46	0	798.51	46	939.06	0	0.00
-----					-----			
LARGEST KW		50	TOTALS	10,475.39		10,888.58		

SUMMARY ACCOUNT: 273-5969-99

ACCOUNT NUM: 131-9889-99 4569,BELTLINE
 CITY OF: TOWN OF ADDISON INDUSTRIAL CODE: 09826
 REVENUE CODE: 03
 BILLING RATE: 540 -- MISCELLANEOUS MUNICIPAL SERVICE

COMPARISON OF TU ELECTRIC BILLING RATES

HISTORICAL				ALTERNATE RATES				
	KWH	ACTUAL KW	BILL KW	MS 540 ***	BILL KW	GS 200 ***	BILL KW	***
***	*****	*****	****	***	****	***	****	***
PR	1.235	0	0	105.29	10	114.05	0	0.00
AR	1.339	0	0	112.91	10	122.49	0	0.00
EB	1.086	0	0	94.41	10	101.99	0	0.00
AN	1.222	0	0	104.35	10	113.02	0	0.00
EC	1.112	0	0	96.08	10	103.95	0	0.00
DV	1.060	0	0	92.33	10	99.76	0	0.00
ST	1.154	0	0	117.77	10	107.28	0	0.00
EP	1.314	0	0	132.38	10	120.47	0	0.00
JG	1.232	0	0	125.06	10	113.84	0	0.00
LY	1.101	0	0	113.19	10	103.12	0	0.00
JN	1.309	0	0	131.71	10	119.93	0	0.00
AY	1.019	0	0	89.34	10	96.45	0	0.00
-----				-----				
LARGEST KW		0	TOTALS	1,314.82		1,316.35		

SUMMARY ACCOUNT: 273-5969-99

ACCOUNT NUM: 131-9982-99 4299, BELTLINE
 CITY OF: TOWN OF ADDISON INDUSTRIAL CODE: 09826
 REVENUE CODE: 03
 BILLING RATE: 540 - MISCELLANEOUS MUNICIPAL SERVICE

COMPARISON OF TU ELECTRIC BILLING RATES

HISTORICAL					ALTERNATE RATES			
	KWH	ACTUAL	BILL	MS	BILL	GS	BILL	
	*****	KW	KW	540	KW	200	KW	***
***	*****	*****	*****	***	*****	***	*****	***
PR	2.131	0	0	170.80	10	186.65	0	0.00
AR	2.106	0	0	169.01	10	184.64	0	0.00
EB	2.141	0	0	171.55	10	187.48	0	0.00
AN	2.136	0	0	171.19	10	187.07	0	0.00
EC	2.204	0	0	175.70	10	192.27	0	0.00
OV	1.990	0	0	160.19	10	175.01	0	0.00
CT	2.049	0	0	197.48	10	179.63	0	0.00
EP	2.199	0	0	211.43	10	192.18	0	0.00
JG	2.056	0	0	198.67	10	180.60	0	0.00
LY	2.199	0	0	211.11	10	192.00	0	0.00
JN	2.383	0	0	227.48	10	206.85	0	0.00
AY	2.158	0	0	172.42	10	188.60	0	0.00
-----					-----			
LARGEST KW		0	TOTALS	2.237.03		2.252.98		

SUMMARY ACCOUNT: 273-5969-99

ACCOUNT NUM: 132-0571-99

MIDWAY & LINDBERG

CITY OF: TOWN OF ADDISON

INDUSTRIAL CODE: 09826

REVENUE CODE: 03

BILLING RATE: 540 - MISCELLANEOUS MUNICIPAL SERVICE

COMPARISON OF TU ELECTRIC BILLING RATES

HISTORICAL					ALTERNATE RATES			
	KWH	ACTUAL KW	BILL KW	MS 540	BILL KW	GS 200	BILL KW	
**	*****	*****	*****	***	*****	***	*****	***
PR	1.198	0	0	102.58	10	111.06	0	0.00
AR	1.173	0	0	100.78	10	109.04	0	0.00
EB	1.249	0	0	106.34	10	115.20	0	0.00
AN	1.241	0	0	105.74	10	114.56	0	0.00
EC	1.322	0	0	111.39	10	120.93	0	0.00
DV	1.219	0	0	103.94	10	112.63	0	0.00
DT	1.286	0	0	129.52	10	117.96	0	0.00
EP	1.362	0	0	136.66	10	124.36	0	0.00
JG	1.248	0	0	126.49	10	115.13	0	0.00
LY	1.364	0	0	136.65	10	124.41	0	0.00
JN	1.419	0	0	141.53	10	128.84	0	0.00
AY	1.295	0	0	109.47	10	118.78	0	0.00
LARGEST KW		0 TOTALS		1.411.09	1.412.90			

SUMMARY ACCOUNT: 273-5969-99

ACCOUNT NUM: 133-3002-99

15348,ADDISON.0SIG

CITY OF: TOWN OF ADDISON

INDUSTRIAL CODE: 09827

REVENUE CODE: 04

BILLING RATE: 540 -- MISCELLANEOUS MUNICIPAL SERVICE

COMPARISON OF TU ELECTRIC BILLING RATES

HISTORICAL					ALTERNATE RATES			
	KWH	ACTUAL	BILL	MS	BILL	GS	BILL	
		KW	KW	540	KW	200	KW	
**	*****	*****	*****	***	*****	***	*****	***
PR	2.297	0	0	182.94	10	200.09	0	0.00
AR	2.278	0	0	181.58	10	198.57	0	0.00
EB	2.332	0	0	185.52	10	202.96	0	0.00
AN	2.363	0	0	187.78	10	205.45	0	0.00
EC	2.398	0	0	189.84	10	207.96	0	0.00
WV	2.256	0	0	179.61	10	196.53	0	0.00
BT	2.415	0	0	230.08	10	209.22	0	0.00
EP	2.577	0	0	245.19	10	220.48	0	0.00
JG	2.321	0	0	222.35	10	202.07	0	0.00
LY	2.480	0	0	236.17	10	214.74	0	0.00
JN	2.570	0	0	244.16	10	219.88	0	0.00
Y	2.320	0	0	184.25	10	201.71	0	0.00
-----					-----			
LARGEST KW		0	TOTALS	2.469.47		2.479.66		

SUMMARY ACCOUNT: 273-5969-99

ACCOUNT NUM: 133-3932-99 ADDISON THEATRE
 CITY OF: TOWN OF ADDISON INDUSTRIAL CODE: 09827
 REVENUE CODE: 04
 BILLING RATE: 540 - MISCELLANEOUS MUNICIPAL SERVICE

COMPARISON OF TU ELECTRIC BILLING RATES

HISTORICAL					ALTERNATE RATES			
	KWH	ACTUAL KW	BILL KW	MS 540	BILL KW	GS 200	BILL KW	
**	*****	*****	*****	***	*****	***	*****	***
PR	60	0	0	19.39	10	18.87	0	0.00
NR	48	0	0	18.51	10	17.89	0	0.00
EB	60	0	0	19.39	10	18.87	0	0.00
AN	60	0	0	19.39	10	18.87	0	0.00
EC	216	1	0	30.75	10	31.47	0	0.00
UV	300	5	0	36.89	10	38.27	0	0.00
DT	936	13	0	98.35	10	89.66	0	0.00
EP	252	1	0	37.51	10	34.42	0	0.00
JG	120	1	0	25.72	10	23.72	0	0.00
LY	456	2	0	55.66	10	50.91	0	0.00
IN	96	2	0	23.56	10	21.77	0	0.00
AY	144	1	0	25.50	10	25.65	0	0.00
LARGEST KW		13	TOTALS	410.62	390.37			

SUMMARY ACCOUNT: 273-5969-99

ACCOUNT NUM: 133-5048-99

4953,AIRPORT

CITY OF: TOWN OF ADDISON

INDUSTRIAL CODE: 09826

REVENUE CODE: 03

BILLING RATE: 540 - MISCELLANEOUS MUNICIPAL SERVICE

COMPARISON OF TU ELECTRIC BILLING RATES

HISTORICAL					ALTERNATE RATES			
	KWH	ACTUAL	BILL	MS	BILL	GS	BILL	
	*****	*****	*****	540	KW	200	KW	***
				***	*****	***	*****	***
PR	1.312	0	0	110.92	10	120.30	0	0.00
AR	1.372	0	0	115.33	10	125.17	0	0.00
EB	1.462	0	0	121.91	10	132.46	0	0.00
AN	1.461	0	0	121.83	10	132.37	0	0.00
EC	1.538	0	0	127.14	10	138.40	0	0.00
OV	1.359	0	0	114.15	10	123.95	0	0.00
BT	1.313	0	0	131.94	10	120.14	0	0.00
EP	1.521	0	0	150.87	10	137.24	0	0.00
JG	998	0	0	104.16	10	94.87	0	0.00
LY	1.467	0	0	145.82	10	132.74	0	0.00
JN	1.523	0	0	150.80	10	137.25	0	0.00
AY	1.372	0	0	115.09	10	125.01	0	0.00
LARGEST KW		0	TOTALS	1,509.96	1,519.90			

SUMMARY ACCOUNT: 273-5969-99

ACCOUNT NUM: 133-6164-99 5001,KELLER SPRINGS
 CITY OF: TOWN OF ADDISON INDUSTRIAL CODE: 09826
 REVENUE CODE: 03
 BILLING RATE: 540 - MISCELLANEOUS MUNICIPAL SERVICE

COMPARISON OF TU ELECTRIC BILLING RATES

HISTORICAL					ALTERNATE RATES			
	KWH	ACTUAL KW	BILL KW	MS 540 ***	BILL KW	GS 200 ***	BILL KW	***
****	*****	*****	****	***	****	***	****	***
PR	1.415	0	0	118.45	10	128.64	0	0.00
AR	1.336	0	0	112.70	10	122.26	0	0.00
EB	1.384	0	0	116.20	10	126.14	0	0.00
AN	1.412	0	0	118.24	10	128.40	0	0.00
EC	1.523	0	0	126.05	10	137.19	0	0.00
DU	1.305	0	0	110.21	10	119.59	0	0.00
BT	640	0	0	72.00	10	65.73	0	0.00
EP	2.108	0	0	203.30	10	184.81	0	0.00
JG	1.276	0	0	128.99	10	117.40	0	0.00
LY	1.365	0	0	136.73	10	124.49	0	0.00
JN	1.559	0	0	154.01	10	140.17	0	0.00
AY	1.407	0	0	117.65	10	127.84	0	0.00
LARGEST KW		0	TOTALS	1.514.53	1.522.66			

SUMMARY ACCOUNT: 273-5969-99

ACCOUNT NUM: 133-8210-99

SOJOURN & ADDISON RD

CITY OF: TOWN OF ADDISON

INDUSTRIAL CODE: 09826

REVENUE CODE: 03

BILLING RATE: 540 - MISCELLANEOUS MUNICIPAL SERVICE

COMPARISON OF TU ELECTRIC BILLING RATES

HISTORICAL					ALTERNATE RATES			
	KWH	ACTUAL KW	BILL KW	MS 540	BILL KW	GS 200	BILL KW	
	*****	*****	*****	***	*****	***	*****	***
PR	1.158	0	0	99.66	10	107.82	0	0.00
NR	1.108	0	0	96.02	10	103.78	0	0.00
EB	1.192	0	0	102.17	10	110.58	0	0.00
AN	1.188	0	0	101.86	10	110.25	0	0.00
EC	1.108	0	0	95.78	10	103.62	0	0.00
DV	1.015	0	0	89.05	10	96.12	0	0.00
BT	1.068	0	0	110.11	10	100.33	0	0.00
EP	1.115	0	0	114.60	10	104.34	0	0.00
JG	1.027	0	0	106.75	10	97.23	0	0.00
LY	1.106	0	0	113.63	10	103.52	0	0.00
LN	1.261	0	0	127.44	10	116.06	0	0.00
AY	1.161	0	0	99.70	10	107.94	0	0.00
LARGEST KW		0	TOTALS	1.256.77	1.261.59			

SUMMARY ACCOUNT: 273-5969-99

ACCOUNT NUM: 134-1744-99

WESTGROVE & ADDISON

CITY OF: TOWN OF ADDISON

INDUSTRIAL CODE: 09826

REVENUE CODE: 03

BILLING RATE: 540 -- MISCELLANEOUS MUNICIPAL SERVICE

COMPARISON OF TU ELECTRIC BILLING RATES

HISTORICAL					ALTERNATE RATES			
	KWH	ACTUAL	BILL	MS	BILL	GS	BILL	
	*****	*****	*****	540	KW	200	KW	***
				***	*****	***	*****	***
PR	1.267	0	0	107.63	10	116.65	0	0.00
NR	1.161	0	0	99.90	10	108.07	0	0.00
EB	1.026	0	0	90.03	10	97.13	0	0.00
YN	1.080	0	0	93.97	10	101.51	0	0.00
IC	1.175	0	0	100.68	10	109.04	0	0.00
JV	1.083	0	0	94.02	10	101.62	0	0.00
ET	1.151	0	0	117.50	10	107.04	0	0.00
FP	1.261	0	0	127.64	10	116.18	0	0.00
JG	1.146	0	0	117.38	10	106.87	0	0.00
JY	1.221	0	0	123.89	10	112.83	0	0.00
IN	1.309	0	0	131.71	10	119.93	0	0.00
JY	1.187	0	0	101.60	10	110.04	0	0.00
LARGEST KW		0	TOTALS	1.305.95		1.306.91		

SUMMARY ACCOUNT: 273-5969-99

ACCOUNT NUM: 134-1961-99 5024, WESTGROVE
 CITY OF: TOWN OF ADDISON INDUSTRIAL CODE: 09826
 REVENUE CODE: 03
 BILLING RATE: 540 - MISCELLANEOUS MUNICIPAL SERVICE

COMPARISON OF TU ELECTRIC BILLING RATES

HISTORICAL					ALTERNATE RATES			
	KWH	ACTUAL KW	BILL KW	MS 540 ***	BILL KW ****	GS 200 ***	BILL KW ****	***
PR	1.055	0	0	92.14	10	99.48	0	0.00
AR	1.120	0	0	96.90	10	104.75	0	0.00
EB	1.206	0	0	103.19	10	111.71	0	0.00
AN	1.208	0	0	103.32	10	111.88	0	0.00
EC	1.178	0	0	100.89	10	109.27	0	0.00
DV	1.072	0	0	93.21	10	100.73	0	0.00
DT	1.096	0	0	112.60	10	102.59	0	0.00
EP	1.164	0	0	118.98	10	108.31	0	0.00
IG	1.037	0	0	107.64	10	98.04	0	0.00
LY	1.042	0	0	107.93	10	98.34	0	0.00
JN	1.155	0	0	117.99	10	107.48	0	0.00
AY	1.102	0	0	95.40	10	103.16	0	0.00
LARGEST KW		0	TOTALS	1,250.19	1,255.74			

SUMMARY ACCOUNT: 273-5969-99

ACCOUNT NUM: 134-4720-99

KELLER SPR & ADDISON

CITY OF: TOWN OF ADDISON

INDUSTRIAL CODE: 09826

REVENUE CODE: 03

BILLING RATE: 540 - MISCELLANEOUS MUNICIPAL SERVICE

COMPARISON OF TU ELECTRIC BILLING RATES

HISTORICAL					ALTERNATE RATES			
	KWH	ACTUAL	BILL	MS	BILL	GS	BILL	
	*****	*****	*****	540	KW	200	KW	***
				***	*****	***	*****	***
PR	1.270	0	0	107.85	10	116.90	0	0.00
AR	1.216	0	0	103.92	10	112.52	0	0.00
EB	1.241	0	0	105.75	10	114.56	0	0.00
AN	1.243	0	0	105.89	10	114.72	0	0.00
EC	1.287	0	0	108.85	10	118.10	0	0.00
DV	1.172	0	0	100.51	10	108.82	0	0.00
CT	1.263	0	0	127.48	10	116.09	0	0.00
EP	1.248	0	0	126.48	10	115.12	0	0.00
JG	1.213	0	0	123.37	10	112.30	0	0.00
LY	1.324	0	0	133.08	10	121.17	0	0.00
JN	1.387	0	0	138.67	10	126.24	0	0.00
AY	1.274	0	0	107.94	10	117.08	0	0.00
LARGEST KW		0	TOTALS	1,389.79	1,393.62			

SUMMARY ACCOUNT: 273-5969-99

ACCOUNT NUM: 134-7076-99

4665,BELTLINE.@SIG

CITY OF: TOWN OF ADDISON

INDUSTRIAL CODE: 09826

REVENUE CODE: 03

BILLING RATE: 540 - MISCELLANEDUS MUNICIPAL SERVICE

COMPARISON OF TU ELECTRIC BILLING RATES

HISTORICAL					ALTERNATE RATES			
	KWH	ACTUAL	BILL	MS	BILL	GS	BILL	
	*****	KW	KW	540	KW	200	KW	***
	*****	*****	*****	***	*****	***	*****	***
PR	2.286	0	0	182.13	10	199.20	0	0.00
AR	2.155	0	0	172.59	10	188.62	0	0.00
EB	2.111	0	0	169.36	10	185.04	0	0.00
AN	2.108	0	0	169.14	10	184.80	0	0.00
EC	2.161	0	0	172.57	10	188.80	0	0.00
IV	1.959	0	0	157.93	10	172.50	0	0.00
CT	2.049	0	0	197.48	10	179.63	0	0.00
EP	2.148	0	0	206.87	10	188.04	0	0.00
JG	1.990	0	0	192.78	10	175.25	0	0.00
LY	2.145	0	0	206.29	10	187.62	0	0.00
JN	2.290	0	0	219.19	10	199.33	0	0.00
AY	2.180	0	0	174.04	10	190.39	0	0.00
LARGEST KW		0 TOTALS		2,220.37	2,239.22			

SUMMARY ACCOUNT: 273-5969-99

ACCOUNT NUM: 195-0832-99 3881,BELTLINE.@SIG
 CITY OF: TOWN OF ADDISON INDUSTRIAL CODE: 09826
 REVENUE CODE: 03
 BILLING RATE: 540 - MISCELLANEOUS MUNICIPAL SERVICE

COMPARISON OF TU ELECTRIC BILLING RATES

HISTORICAL					ALTERNATE RATES			
	KWH	ACTUAL KW	BILL KW	MS 540	BILL KW	GS 200	BILL KW	
***	*****	*****	*****	***	*****	***	*****	***
PR	1.965	0	0	158.66	10	173.20	0	0.00
AR	1.386	0	0	116.35	10	126.30	0	0.00
EB	1.753	0	0	143.18	10	156.04	0	0.00
AN	1.888	0	0	153.05	10	166.96	0	0.00
EC	1.693	0	0	138.44	10	150.94	0	0.00
JV	1.668	0	0	136.70	10	148.95	0	0.00
DT	1.642	0	0	161.24	10	146.74	0	0.00
EP	1.831	0	0	178.55	10	162.36	0	0.00
JG	1.590	0	0	157.04	10	142.84	0	0.00
LY	1.659	0	0	162.95	10	148.28	0	0.00
JN	1.774	0	0	173.18	10	157.57	0	0.00
AY	1.614	0	0	132.75	10	144.59	0	0.00
LARGEST KW		0	TOTALS	1.812.09	1.824.77			

SUMMARY ACCOUNT: 273-5969-99

ACCOUNT NUM: 263-9404-99

4008, DOME

CITY OF: TOWN OF ADDISON

INDUSTRIAL CODE: 09822

REVENUE CODE: 04

BILLING RATE: 540 - MISCELLANEOUS MUNICIPAL SERVICE

COMPARISON OF TU ELECTRIC BILLING RATES

----- HISTORICAL -----					----- ALTERNATE RATES -----			
	KWH	ACTUAL	BILL	MS	BILL	GS	BILL	
		KW	KW	540	KW	200	KW	
	*****	*****	****	***	****	***	****	***
PR	254	0	0	33.58	10	34.58	0	0.00
AR	278	0	0	35.33	10	36.52	0	0.00
EB	319	0	0	38.33	10	39.85	0	0.00
AN	342	0	0	40.01	10	41.71	0	0.00
EC	338	0	0	39.65	10	41.34	0	0.00
DV	313	0	0	37.83	10	39.32	0	0.00
CT	230	0	0	35.48	10	32.59	0	0.00
EP	202	0	0	33.04	10	30.36	0	0.00
JG	174	0	0	30.54	10	28.10	0	0.00
LY	177	0	0	30.78	10	28.33	0	0.00
JN	183	0	0	31.31	10	28.80	0	0.00
AY	211	0	0	30.39	10	31.07	0	0.00
-----					-----			
LARGEST KW		0	TOTALS	416.27		412.57		

SUMMARY ACCOUNT: 273-5969-99

ACCOUNT NUM: 264-1853-99 3960, BELTWAY
 CITY OF: TOWN OF ADDISON INDUSTRIAL CODE: 09822
 REVENUE CODE: 04
 BILLING RATE: 540 - MISCELLANEOUS MUNICIPAL SERVICE

COMPARISON OF TU ELECTRIC BILLING RATES

HISTORICAL					ALTERNATE RATES			
	KWH	ACTUAL KW	BILL KW	MS 540	BILL KW	GS 200	BILL KW	
	*****	*****	****	***	*****	***	****	***
PR	218	0	0	30.95	10	31.67	0	0.00
NR	249	0	0	33.21	10	34.17	0	0.00
EB	305	0	0	37.30	10	38.71	0	0.00
AN	340	0	0	39.86	10	41.54	0	0.00
IC	334	0	0	39.35	10	41.01	0	0.00
TV	292	0	0	36.31	10	37.63	0	0.00
DT	209	0	0	33.61	10	30.90	0	0.00
EP	194	0	0	32.33	10	29.72	0	0.00
JG	166	0	0	29.83	10	27.45	0	0.00
LY	157	0	0	29.00	10	26.71	0	0.00
JN	175	0	0	30.60	10	28.16	0	0.00
AY	175	0	0	27.77	10	28.16	0	0.00
LARGEST KW		0	TOTALS	400.12			395.83	

SUMMARY ACCOUNT: 273-5969-99

ACCOUNT NUM: 264-3279-99 3950,BELTWAY
 CITY OF: TOWN OF ADDISON INDUSTRIAL CODE: 09827
 REVENUE CODE: 04
 BILLING RATE: 540 - MISCELLANEOUS MUNICIPAL SERVICE

COMPARISON OF TU ELECTRIC BILLING RATES

HISTORICAL					ALTERNATE RATES			
	KWH	ACTUAL	BILL	MS	BILL	GS	BILL	
	*****	*****	****	540	KW	200	KW	***
				***	*****	***	****	
EV	5.640	19	0	427.36	18	444.00	0	0.00
J	5.760	20	0	436.19	18	450.15	0	0.00
**	7.560	19	0	567.81	18	536.85	0	0.00
PR	6.000	22	0	453.72	18	462.37	0	0.00
AR	7.080	20	0	531.23	18	516.39	0	0.00
EB	5.880	17	0	444.00	17	447.13	0	0.00
AN	5.640	17	0	517.28	17	434.53	0	0.00
IC	6.480	17	0	593.82	17	478.37	0	0.00
IV	5.760	17	0	529.56	17	441.74	0	0.00
OT	5.520	17	0	507.27	17	429.03	0	0.00
EP	5.880	17	0	539.29	17	447.24	0	0.00
JG	5.760	17	0	435.20	17	441.04	0	0.00
LY								
JN								
AY								
LARGEST KW		22 TOTALS		5.982.73		5.528.84		

SUMMARY ACCOUNT: 273-5969-99

ACCOUNT NUM: 264-8425-99 4000,BELTLINE
 CITY OF: TOWN OF ADDISON INDUSTRIAL CODE: 09826
 REVENUE CODE: 03
 BILLING RATE: 540 - MISCELLANEOUS MUNICIPAL SERVICE

COMPARISON OF TU ELECTRIC BILLING RATES

HISTORICAL					ALTERNATE RATES			
	KWH	ACTUAL	BILL	MS	BILL	GS	BILL	
	*****	*****	****	540	KW	200	KW	****
				***	*****	***	*****	
PR	1.908	0	0	154.50	10	168.58	0	0.00
NR	1.904	0	0	154.24	10	168.28	0	0.00
EB	1.958	0	0	158.17	10	172.65	0	0.00
AN	1.968	0	0	158.91	10	173.45	0	0.00
EC	1.876	0	0	151.79	10	165.75	0	0.00
UV	1.809	0	0	146.99	10	160.37	0	0.00
YT	1.905	0	0	184.65	10	167.99	0	0.00
EP	2.176	0	0	209.37	10	190.31	0	0.00
IG	1.934	0	0	187.77	10	170.71	0	0.00
LY	2.064	0	0	199.07	10	181.06	0	0.00
IN	2.223	0	0	213.21	10	193.90	0	0.00
LY	1.965	0	0	158.35	10	172.99	0	0.00
LARGEST KW		0	TOTALS	2.077.02	2.086.04			

SUMMARY ACCOUNT: 273-5969-99

ACCOUNT NUM: 270-9960-99 3901, SPRING VALLEY
 CITY OF: TOWN OF ADDISON INDUSTRIAL CODE: 09826
 REVENUE CODE: 03
 BILLING RATE: 540 - MISCELLANEOUS MUNICIPAL SERVICE

COMPARISON OF TU ELECTRIC BILLING RATES

HISTORICAL					ALTERNATE RATES			
	KWH	ACTUAL	BILL	MS	BILL	GS	BILL	
		KW	KW	540	KW	200	KW	
***	*****	*****	****	***	****	***	****	***
PR	1.460	0	0	121.74	10	132.29	0	0.00
NR	1.403	0	0	117.59	10	127.68	0	0.00
EB	1.471	0	0	122.57	10	133.19	0	0.00
AN	1.555	0	0	128.70	10	139.99	0	0.00
EC	1.515	0	0	125.46	10	136.54	0	0.00
DV	1.409	0	0	117.81	10	128.00	0	0.00
BT	1.403	0	0	139.94	10	127.41	0	0.00
EP	1.453	0	0	144.79	10	131.73	0	0.00
JG	1.254	0	0	127.02	10	115.61	0	0.00
LY	1.303	0	0	131.20	10	119.47	0	0.00
JN	1.373	0	0	137.43	10	125.12	0	0.00
AY	1.254	0	0	106.48	10	115.45	0	0.00
-----					-----			
LARGEST KW		0	TOTALS	1.520.73		1.532.48		

SUMMARY ACCOUNT: 273-5969-99

ACCOUNT NUM: 271-0115-99 SIDNEY RD SOUTH
 CITY OF: TOWN OF ADDISON INDUSTRIAL CODE: 09826
 REVENUE CODE: 03
 BILLING RATE: 540 - MISCELLANEOUS MUNICIPAL SERVICE

COMPARISON OF TU ELECTRIC BILLING RATES

HISTORICAL					ALTERNATE RATES			
	KWH	ACTUAL KW	BILL KW	MS 540	BILL KW	GS 200	BILL KW	
***	*****	*****	****	***	*****	***	****	***
PR	837	0	0	76.20	10	81.81	0	0.00
AR	856	0	0	77.60	10	83.36	0	0.00
EB	937	0	0	83.52	10	89.92	0	0.00
AN	843	0	0	76.63	10	82.30	0	0.00
EC	878	0	0	79.02	10	85.02	0	0.00
UV	818	0	0	74.68	10	80.18	0	0.00
DT	330	0	0	44.39	10	40.68	0	0.00
EP	295	0	0	41.35	10	37.90	0	0.00
JG	430	0	0	53.41	10	48.84	0	0.00
LY	441	0	0	54.34	10	49.70	0	0.00
IN	400	0	0	50.67	10	46.37	0	0.00
AY	614	0	0	59.79	10	63.68	0	0.00
LARGEST KW				0 TOTALS	771.60	789.76		

SUMMARY ACCOUNT: 273-5969-99

ACCOUNT NUM: 272-1151-99 3800, SPRING VALLEY
 CITY OF: TOWN OF ADDISON INDUSTRIAL CODE: 09826
 REVENUE CODE: 03
 BILLING RATE: 540 - MISCELLANEOUS MUNICIPAL SERVICE

COMPARISON OF TU ELECTRIC BILLING RATES

HISTORICAL					ALTERNATE RATES			
	KWH	ACTUAL KW	BILL KW	MS 540	BILL KW	GS 200	BILL KW	
	*****	*****	****	***	*****	***	****	***
EV	4	0	0	15.30	10	14.33	0	0.00
J	6	0	0	15.44	10	14.48	0	0.00
**	2	0	0	15.15	10	14.16	0	0.00
AR	8	0	0	15.58	10	14.65	0	0.00
AR	7	0	0	15.51	10	14.56	0	0.00
EB	8	0	0	15.58	10	14.65	0	0.00
AN	7	0	0	15.51	10	14.56	0	0.00
EC	8	0	0	15.58	10	14.65	0	0.00
OV	7	0	0	15.62	10	14.56	0	0.00
OT	6	0	0	15.53	10	14.48	0	0.00
EP	8	0	0	15.71	10	14.65	0	0.00
JG	0	0	0	15.00	10	14.00	0	0.00
LY	4	0	0	15.36	10	14.33	0	0.00
JN	5	0	0	15.36	10	14.40	0	0.00
AY								
LARGEST KW				0	TOTALS		185.14	173.25

SUMMARY ACCOUNT: 273-5969-99

ACCOUNT NUM: 605-2070-99

SPRG & LANDSCAPE LIGHTING

CITY OF: TOWN OF ADDISON

INDUSTRIAL CODE: 09822

REVENUE CODE: 04

BILLING RATE: 540 - MISCELLANEOUS MUNICIPAL SERVICE

COMPARISON OF TU ELECTRIC BILLING RATES

HISTORICAL					ALTERNATE RATES			
	KWH	ACTUAL KW	BILL KW	MS 540 ***	BILL KW	GS 200 ***	BILL KW	***
*****	*****	*****	*****	***	*****	***	*****	***
PR	0	0	0	15.00	10	14.00	0	0.00
AR	0	0	0	15.00	10	14.00	0	0.00
EB	0	0	0	15.00	10	14.00	0	0.00
YN	0	0	0	15.00	10	14.00	0	0.00
IC	0	0	0	15.00	10	14.00	0	0.00
OV	0	0	0	15.00	10	14.00	0	0.00
OT	0	0	0	15.00	10	14.00	0	0.00
EP	96	0	0	23.58	10	21.78	0	0.00
IG	177	0	0	30.81	10	28.34	0	0.00
LY	186	0	0	31.58	10	29.05	0	0.00
IN	237	0	0	36.13	10	33.19	0	0.00
AY	259	0	0	33.89	10	34.95	0	0.00
LARGEST KW		0 TOTALS		260.99	245.31			

SUMMARY ACCOUNT: 273-5969-99

ACCOUNT NUM: 605-2132-99

CITY OF ADDISON/15581 DALLAS PKWY SPR

CITY OF: TOWN OF ADDISON

INDUSTRIAL CODE: 09822

REVENUE CODE: 04

BILLING RATE: 540 - MISCELLANEOUS MUNICIPAL SERVICE

COMPARISON OF TU ELECTRIC BILLING RATES

----- HISTORICAL -----					----- ALTERNATE RATES -----			
	KWH	ACTUAL	BILL	MS	BILL	GS	BILL	
	*****	*****	****	540	KW	200	KW	***
				***	****	***	****	***
PR	0	0	0	15.00	10	14.00	0	0.00
AR	0	0	0	15.00	10	14.00	0	0.00
EB	0	0	0	15.00	10	14.00	0	0.00
AN	0	0	0	15.00	10	14.00	0	0.00
EC	0	0	0	15.00	10	14.00	0	0.00
IV	0	0	0	15.00	10	14.00	0	0.00
ST	14	0	0	16.25	10	15.13	0	0.00
EP	427	0	0	53.14	10	48.60	0	0.00
JG	335	0	0	44.92	10	41.14	0	0.00
LY	201	0	0	32.92	10	30.26	0	0.00
JN	342	0	0	45.50	10	41.68	0	0.00
AY	332	0	0	39.21	10	40.86	0	0.00
-----					-----			
LARGEST KW		0	TOTALS	321.94		301.67		

SUMMARY ACCOUNT: 273-5969-99

ACCOUNT NUM: 605-4705-99

CITY OF ADDISON/5090 BELTLINE SPR

CITY OF: TOWN OF ADDISON

INDUSTRIAL CODE: 09822

REVENUE CODE: 04

BILLING RATE: 540 - MISCELLANEOUS MUNICIPAL SERVICE

COMPARISON OF TU ELECTRIC BILLING RATES

HISTORICAL					ALTERNATE RATES			
	KWH	ACTUAL KW	BILL KW	MS 540 ***	BILL KW	GS 200 ***	BILL KW	***
	*****	*****	*****	***	*****	***	*****	***
AR	0	0	0	15.00	10	14.00	0	0.00
AR	0	0	0	15.00	10	14.00	0	0.00
EB	0	0	0	15.00	10	14.00	0	0.00
AN	0	0	0	15.00	10	14.00	0	0.00
EC	0	0	0	15.00	10	14.00	0	0.00
IV	0	0	0	15.00	10	14.00	0	0.00
ST	0	0	0	15.00	10	14.00	0	0.00
EP	0	0	0	15.00	10	14.00	0	0.00
IG	0	0	0	15.00	10	14.00	0	0.00
LY	0	0	0	15.00	10	14.00	0	0.00
IN	0	0	0	15.00	10	14.00	0	0.00
AY	0	0	0	15.00	10	14.00	0	0.00
LARGEST KW				0 TOTALS	168.00			

SUMMARY ACCOUNT: 273-5969-99

ACCOUNT NUM: 613-1926-99 5430 CELESTIAL
 CITY OF: TOWN OF ADDISON INDUSTRIAL CODE: 09831
 REVENUE CODE: 04
 BILLING RATE: 540 - MISCELLANEOUS MUNICIPAL SERVICE

COMPARISON OF TU ELECTRIC BILLING RATES

HISTORICAL					ALTERNATE RATES			
	KWH	ACTUAL	BILL	MS	BILL	GS	BILL	
	*****	KW	KW	540	KW	200	KW	***
	*****	*****	****	***	*****	***	****	***
ER	643	0	0	62.01	10	66.09	0	0.00
AR	624	0	0	60.63	10	64.56	0	0.00
EB	631	0	0	61.14	10	65.13	0	0.00
AN	719	0	0	67.58	10	72.26	0	0.00
EC	659	0	0	63.05	10	67.30	0	0.00
OV	590	0	0	58.05	10	61.74	0	0.00
CT	347	0	0	45.91	10	42.05	0	0.00
EP	333	0	0	44.74	10	40.98	0	0.00
JG	357	0	0	46.89	10	42.93	0	0.00
LY	357	0	0	46.84	10	42.90	0	0.00
JN	354	0	0	46.56	10	42.65	0	0.00
AY	404	0	0	44.48	10	46.69	0	0.00
-----					-----			
LARGEST KW		0	TOTALS	647.88		655.28		

SUMMARY ACCOUNT: 273-5969-99

ACCOUNT NUM: 613-4995-99

5081 WESTGROVE

CITY OF: TOWN OF ADDISON

INDUSTRIAL CODE: 09827

REVENUE CODE: 04

BILLING RATE: 540 - MISCELLANEOUS MUNICIPAL SERVICE

COMPARISON OF TU ELECTRIC BILLING RATES

HISTORICAL					ALTERNATE RATES			
CU	MS	ACTUAL	BILL	MS	BILL	GS	BILL	
3		KW	KW	540	KW	200	KW	
**	*****	*****	*****	***	*****	***	*****	***
PR	43	0	0	18.14	10	17.48	0	0.00
AR	43	0	0	18.14	10	17.48	0	0.00
EB	50	0	0	18.66	10	18.06	0	0.00
AN	51	0	0	18.73	10	18.14	0	0.00
EC	57	0	0	19.16	10	18.61	0	0.00
CV	60	0	0	19.38	10	18.86	0	0.00
CT	63	0	0	20.61	10	19.09	0	0.00
EP	43	0	0	18.84	10	17.48	0	0.00
JG	37	0	0	18.30	10	17.00	0	0.00
LY	39	0	0	18.48	10	17.16	0	0.00
JN	41	0	0	18.66	10	17.33	0	0.00
AY	39	0	0	17.84	10	17.16	0	0.00
LARGEST KW		0 TOTALS		224.94	213.85			

SUMMARY ACCOUNT: 273-5969-99

ACCOUNT NUM: 616-8785-99

CORNER OF CELESTIAL & MONTFORT

CITY OF: TOWN OF ADDISON

INDUSTRIAL CODE: 09831

REVENUE CODE: 04

BILLING RATE: 540 - MISCELLANEOUS MUNICIPAL SERVICE

COMPARISON OF TU ELECTRIC BILLING RATES

HISTORICAL					ALTERNATE RATES			
	KWH	ACTUAL KW	BILL KW	MS 540	BILL KW	GS 200	BILL KW	
	*****	*****	*****	***	*****	***	*****	***
PR	49	0	0	18.59	10	17.97	0	0.00
AR	52	0	0	18.80	10	18.21	0	0.00
EB	55	0	0	19.02	10	18.46	0	0.00
AN	65	0	0	19.75	10	19.27	0	0.00
EC	58	0	0	19.23	10	18.69	0	0.00
DV	57	0	0	19.16	10	18.61	0	0.00
OT	52	0	0	19.63	10	18.20	0	0.00
EP	47	0	0	19.20	10	17.81	0	0.00
JG	45	0	0	19.02	10	17.64	0	0.00
LY	44	0	0	18.92	10	17.56	0	0.00
JN	46	0	0	19.10	10	17.73	0	0.00
AY	44	0	0	18.20	10	17.55	0	0.00
LARGEST KW		0	TOTALS	228.62			217.70	

SUMMARY ACCOUNT: 273-5969-99

ACCOUNT NUM: 625-4252-99 PARK FOUNTAIN
 CITY OF: TOWN OF ADDISON INDUSTRIAL CODE: 09827
 REVENUE CODE: 04
 BILLING RATE: 540 - MISCELLANEOUS MUNICIPAL SERVICE

COMPARISON OF TU ELECTRIC BILLING RATES

HISTORICAL					ALTERNATE RATES			
	KWH	ACTUAL KW	BILL KW	MS 540 ***	BILL KW	GS 200 ***	BILL KW	***
***	*****	*****	****	***	****	***	****	***
PR	8.400	35	0	629.15	33	711.25	0	0.00
AR	6.100	35	0	461.06	33	594.18	0	0.00
EB	5.720	29	0	433.26	29	541.04	0	0.00
AN	8.640	32	0	646.76	32	715.07	0	0.00
EC	10.380	36	0	771.84	33	799.04	0	0.00
OV	9.760	36	0	727.09	33	779.43	0	0.00
OT	7.720	34	0	702.52	33	675.23	0	0.00
EP	7.760	32	0	708.16	32	670.28	0	0.00
IG	7.100	31	0	649.27	31	628.26	0	0.00
LY	7.620	32	0	694.55	32	662.53	0	0.00
IN	8.640	32	0	785.40	32	714.25	0	0.00
AY	9.860	35	0	734.30	35	801.43	0	0.00
-----					-----			
LARGEST KW		36	TOTALS	7.943.36		8.291.99		

SUMMARY ACCOUNT: 273-5969-99

ACCOUNT NUM: 635-5002-99

SPRINKLER/LIGHTING?

CITY OF: TOWN OF ADDISON

INDUSTRIAL CODE: 09827

REVENUE CODE: 04

BILLING RATE: 540 - MISCELLANEOUS MUNICIPAL SERVICE

COMPARISON OF TU ELECTRIC BILLING RATES

HISTORICAL					ALTERNATE RATES			
	KWH	ACTUAL	BILL	MS	BILL	GS	BILL	
	*****	*****	*****	540	KW	200	KW	*****
				***	*****	***	*****	***
PR	80	0	0	20.85	10	20.48	0	0.00
NR	78	0	0	20.71	10	20.32	0	0.00
EB	84	0	0	21.14	10	20.81	0	0.00
AN	87	0	0	21.37	10	21.05	0	0.00
EC	85	0	0	21.20	10	20.88	0	0.00
DV	79	0	0	20.77	10	20.40	0	0.00
DT	80	0	0	22.12	10	20.46	0	0.00
EP	91	0	0	23.13	10	21.37	0	0.00
JG	102	0	0	24.11	10	22.26	0	0.00
LY	137	0	0	27.21	10	25.09	0	0.00
JN	146	0	0	28.02	10	25.82	0	0.00
AY	127	0	0	24.26	10	24.28	0	0.00
LARGEST KW		0 TOTALS		274.89	263.22			

SUMMARY ACCOUNT: 273-5969-99

ACCOUNT NUM: 704-0691-99 4078 BELTLINE

CITY OF: TOWN OF ADDISON INDUSTRIAL CODE: 09826

REVENUE CODE: 03

BILLING RATE: 540 - MISCELLANEOUS MUNICIPAL SERVICE

COMPARISON OF TU ELECTRIC BILLING RATES

HISTORICAL					ALTERNATE RATES			
	KWH	ACTUAL	BILL	MS	BILL	GS	BILL	
	*****	*****	****	540	KW	200	KW	****
				***	****	***	****	***
PR	1.700	0	0	139.29	10	151.73	0	0.00
AR	1.660	0	0	136.39	10	148.51	0	0.00
EB	1.673	0	0	137.33	10	149.55	0	0.00
AN	1.725	0	0	141.14	10	153.76	0	0.00
EC	1.683	0	0	137.71	10	150.12	0	0.00
DV	1.583	0	0	130.50	10	142.07	0	0.00
ST	1.596	0	0	157.14	10	143.02	0	0.00
EP	1.908	0	0	185.43	10	168.60	0	0.00
JG	1.631	0	0	160.70	10	146.17	0	0.00
LY	1.695	0	0	166.16	10	151.20	0	0.00
JN	1.879	0	0	182.54	10	166.07	0	0.00
AY	1.675	0	0	137.20	10	149.53	0	0.00
LARGEST KW		0	TOTALS	1,811.53	1,820.33			

RATE APPLICATION REVIEW

TOWN OF ADDISON

PROCESS DATE: 04/28/97

THIS IS TO CERTIFY THAT THE ELECTRIC SERVICE
ACCOUNTS FOR TOWN OF ADDISON
WERE REVIEWED FOR PROPER RATE APPLICATION.

RATE CHANGES REQUESTED ARE LISTED BY PREMISE
NUMBER ON THE ATTACHED SHEETS.

CUSTOMER

TU ELECTRIC

.....
BY

.....
BY

.....
TITLE

Account Executive
.....
TITLE

.....
DATE

May 1, 1997
.....
DATE

SUMMARY ACCOUNT: 273-6031-99

	PREMISE NUMBER	TENN	LOCATION	CURRENT RATE	CHANGE RATE TO :
1)	116-3277-99		TOWN OF ADDISON	500
		14500	INWOOD RD		
2)	116-5819-99		TOWN OF ADDISON	540
		05510	CELESTIAL RD		
3)	133-2661-99		TOWN OF ADDISON	500
		00000	@BELTLINE & A		
4)	194-6027-99		TOWN OF ADDISON	540
		15130	SURVEYOR BLVD		
5)	270-9650-99		TOWN OF ADDISON	500
		00000	@BROOKHAVEN &		

SUMMARY ACCOUNT: 273-6031-99

ACCOUNT NUM: 116-3277-99

DALLAS PKWY

CITY OF: TOWN OF ADDISON

INDUSTRIAL CODE: 09823

REVENUE CODE: 04

BILLING RATE: 500 - MUNICIPAL PUMPING SERVICE

COMPARISON OF TU ELECTRIC BILLING RATES

HISTORICAL					ALTERNATE RATES			
	KWH	ACTUAL KW	BILL KW	MP 500	BILL KW	GS 200	BILL KW	
***	*****	*****	****	***	*****	***	****	***
PR	10	0	0	14.81	10	14.81	0	0.00
NR	17	0	0	15.38	10	15.38	0	0.00
EB	162	0	0	27.13	10	27.13	0	0.00
AN	14	0	0	15.13	10	15.13	0	0.00
EC	8	0	0	14.65	10	14.65	0	0.00
DV	10	0	0	14.81	10	14.81	0	0.00
ST	9	0	0	14.73	10	14.73	0	0.00
EP	7	0	0	14.56	10	14.56	0	0.00
JG	5	0	0	14.40	10	14.40	0	0.00
LY	6	0	0	14.48	10	14.48	0	0.00
IN	16	0	0	15.29	10	15.29	0	0.00
AY	13	0	0	15.06	10	15.06	0	0.00
LARGEST KW		0 TOTALS		190.43	190.43			

SUMMARY ACCOUNT: 273-6031-99

ACCOUNT NUM: 116-5819-99 5510,CELESTIAL.@PUMP
 CITY OF: TOWN OF ADDISON INDUSTRIAL CODE: 09823
 REVENUE CODE: 04
 BILLING RATE: 540 - MISCELLANEOUS MUNICIPAL SERVICE

COMPARISON OF TU ELECTRIC BILLING RATES

HISTORICAL					ALTERNATE RATES			
	KWH	ACTUAL KW	BILL KW	MS 540	BILL KW	GS 200	BILL KW	
***	*****	*****	****	***	****	***	****	***
PR	74.400	348	0	5,454.60	375	6,803.43	0	0.00
AR	72.000	348	0	5,279.93	375	6,741.26	0	0.00
EB	79.200	353	0	5,806.34	375	6,929.28	0	0.00
AN	81.600	356	0	5,981.59	375	6,991.81	0	0.00
EC	72.000	348	0	5,264.73	375	6,731.18	0	0.00
UV	86.400	332	0	6,318.75	375	7,107.35	0	0.00
CT	100.800	620	0	8,991.84	409	7,905.28	0	0.00
EP	105.600	333	0	9,447.72	375	7,619.06	0	0.00
JG	127.200	334	0	11,378.41	375	8,184.13	0	0.00
LY	124.800	335	0	11,144.53	514	9,870.66	0	0.00
JN	112.800	338	0	10,072.92	514	9,556.46	0	0.00
AY	93.600	333	0	6,843.30	514	9,055.03	0	0.00
LARGEST KW		620	TOTALS	91,984.66	93,494.93			

SUMMARY ACCOUNT: 273-6031-99

ACCOUNT NUM: 133-2661-99

BELTLINE & ADDISON

CITY OF: TOWN OF ADDISON

INDUSTRIAL CODE: 09823

REVENUE CODE: 04

BILLING RATE: 500 - MUNICIPAL PUMPING SERVICE

COMPARISON OF TU ELECTRIC BILLING RATES

----- HISTORICAL -----					----- ALTERNATE RATES -----			
	KWH	ACTUAL	BILL	MP	BILL	GS	BILL	
	*****	KW	KW	500	KW	200	KW	***
**	*****	*****	*****	***	*****	***	*****	***
PR	0	0	0	14.00	10	14.00	0	0.00
AR	0	0	0	14.00	10	14.00	0	0.00
EB	0	0	0	14.00	10	14.00	0	0.00
AN	0	0	0	14.00	10	14.00	0	0.00
EC	0	0	0	14.00	10	14.00	0	0.00
DV	0	0	0	14.00	10	14.00	0	0.00
CT	0	0	0	14.00	10	14.00	0	0.00
EP	0	0	0	14.00	10	14.00	0	0.00
JG	0	0	0	14.00	10	14.00	0	0.00
LY	0	0	0	14.00	10	14.00	0	0.00
JN	0	0	0	14.00	10	14.00	0	0.00
AY	106	0	0	22.57	10	22.58	0	0.00
-----					-----			
LARGEST KW		0	TOTALS	176.57		176.58		

SUMMARY ACCOUNT: 273-6031-99

ACCOUNT NUM: 194-6027-99 15130,SURVEYOR
 CITY OF: TOWN OF ADDISON INDUSTRIAL CODE: 09823
 REVENUE CODE: 04
 BILLING RATE: 540 - MISCELLANEOUS MUNICIPAL SERVICE

COMPARISON OF TU ELECTRIC BILLING RATES

HISTORICAL					ALTERNATE RATES			
EV	KWH	ACTUAL	BILL	MS	BILL	GS	BILL	
J		KW	KW	540	KW	200	KW	
**	*****	*****	****	***	*****	***	****	***
PR	17.595	216	0	1.301.42	215	2.716.91	0	0.00
AR	19.125	216	0	1.413.50	215	2.794.95	0	0.00
EB	25.560	216	0	1.884.02	215	3.122.63	0	0.00
AN	20.790	213	0	1.535.17	213	2.862.78	0	0.00
EC	21.825	209	0	1.606.33	209	2.878.70	0	0.00
DV	24.840	199	0	1.827.33	199	2.947.92	0	0.00
CT	25.245	199	0	2.263.22	199	2.966.71	0	0.00
EP	26.280	202	0	2.362.46	202	3.049.50	0	0.00
UG	26.820	200	0	2.410.97	200	3.060.26	0	0.00
LY	27.990	215	0	2.511.13	317	4.105.76	0	0.00
UN	25.155	203	0	2.257.97	317	3.961.23	0	0.00
AY	15.750	199	0	1.163.99	317	3.482.91	0	0.00
-----					-----			
LARGEST KW		216	TOTALS	22,537.51		37,950.26		

SUMMARY ACCOUNT: 273-6031-99

ACCOUNT NUM: 270-9650-99

BROOKHAVEN & MARSH

CITY OF: TOWN OF ADDISON

INDUSTRIAL CODE: 09823

REVENUE CODE: 04

BILLING RATE: 500 - MUNICIPAL PUMPING SERVICE

COMPARISON OF TU ELECTRIC BILLING RATES

	HISTORICAL				ALTERNATE RATES			
	KWH	ACTUAL	BILL	MP	BILL	GS	BILL	
	*****	KW	KW	500	KW	200	KW	***
**	*****	*****	*****	***	*****	***	*****	***
PR	47	0	0	17.81	10	17.81	0	0.00
AR	48	0	0	17.89	10	17.89	0	0.00
EB	57	0	0	18.62	10	18.62	0	0.00
AN	62	0	0	19.02	10	19.02	0	0.00
EC	60	0	0	18.86	10	18.86	0	0.00
OV	53	0	0	18.28	10	18.28	0	0.00
CT	49	0	0	17.96	10	17.96	0	0.00
EP	51	0	0	18.14	10	18.14	0	0.00
UG	42	0	0	17.40	10	17.40	0	0.00
LY	39	0	0	17.15	10	17.16	0	0.00
UN	65	0	0	19.26	10	19.26	0	0.00
AY	72	0	0	19.82	10	19.82	0	0.00
-----					-----			
LARGEST KW		0	TOTALS	220.21		220.22		

HUITT-ZOLLARS

Dallas • Fort Worth • Houston • El Paso • Phoenix • Tustin • Ontario • San Clemente

FACSIMILE TRANSMITTAL

Date: 2/10/97

Fax No.: 972-770-5129

H-Z Proj. No. 01201301

No. of Pages: 2
(Including Cover Sheet)

TO: Columbus Realty Trust
ATTN: BRYANT HAIN

URGENT For Your Review Please Call Upon Receipt Orig. To Follow By Mail

RE: ADDISON CIRCLE I

STREET LIGHT COST COMPARISON.

FROM: David Meyers

SENT BY: _____ TIME: _____ DATE: _____

If you had any problems receiving the Facsimile Transmittal, please contact Ms. Janet Willis or the individual listed above at (214) 871-3311. Thank you.

**ADDISON CIRCLE PHASE I
PUBLIC INFRASTRUCTURE
STREET LIGHT COST COMPARISON
02/10/97**

	TEXAN STYLE 14 FOOT POLE	BEGA 14 FOOT POLE	COST SAVINGS
COST OF POLE AND FIXTURE INSTALLED	\$2,156	\$1,650	\$506
COST OF WIRE PER POLE	\$180	\$160	\$20
COST FOR FOUNDATION AND SQUARE CAP	\$486	\$486	\$0
TUE CREDIT FOR BASIC LIGHT POLE AND FIXTURE	(\$323)	\$0	(\$323)
TOTALS	\$2,479	\$2,296	\$183

55 POLES REMAINING IN PROJECT FOR SAVINGS OF

\$10,065

1. ASSUMES FOUNDATION AND ELECTRICAL WIRING IS THE SAME FOR EACH STYLE POLE.
2. ASSUMES WATTAGE OF BULB IS THE SAME.
3. TUE DOES NOT PROVIDE DESIGN OR MAINTENANCE FOR NON-TUE STANDARD POLE AND FIXTURE.
THE BEGA POLE WILL REQUIRE AN ELECTRICAL DESIGN.
4. BEGA INSTALLED COST BASED ON \$1,300 MATERIALS PLUS 25% FOR INSTALLATION.
5. T.U.E. DOES NOT DESIGN TO NEC. IT IS POSSIBLE THAT FOLLOWING CODE COULD INCREASE WIRE COST.
6. WIRE COST IS FROM T.U.E.; INDEPENDENT CONTRACTOR COST MAY BE HIGHER.
7. PERHAPS THE CONTRACTOR COULD DO A DESIGN-BUILD TO SAVE MONEY ON DESIGN.

**PUBLIC WORKS DEPARTMENT**

(972) 450-2871

Post Office Box 144 Addison, Texas 75001

16801 Westgrove

MEMORANDUM

August 4, 1997

To: Ron Whitehead
City Manager

From: John R. Baumgartner, P.E.
Director of Public Works

Re: Addison Circle Phase I Street Lighting

Attached is a bid from Bolen Resources to supply Bega light fixtures for us in the Addison Circle Project.

The light fixtures represent a portion of the total cost for the project, and the following table identifies other expenses and funding:

Costs:

1.	Engineering Electrical Circuit and Developing Bid Documents	\$5,600.00
2.	Provide Bega fixtures	\$93,174.20
3.	Install Bega fixtures (estimate)	\$23,500.00
4.	Construct lighting circuit (estimate)	\$15,000.00
5.	TU Electric re-stocking fee to Texan light fixtures	\$39,907.75 ★
TOTAL COST		\$177,181.95

Funding:

1.	Allowance from Addison Circle Phase I infrastructure:	\$97,149.00
2.	Addison Circle offsite improvements:	\$80,032.95
TOTAL FUNDS AVAILABLE		\$177,181.915

Staff recommends that the Council award the contract to supply street lights to Addison Circle Phase I to Bollen Industries, Inc. and to authorize staff to proceed with the necessary steps to implement a design/installation change from the Texan lights to the Bega light fixtures.

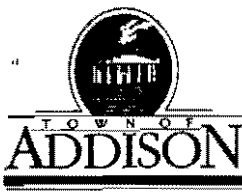

TOWN OF ADDISON

MAIL ALL INVOICES TO:
 Accounts Payable
 P.O. Box 144
 Addison, Texas 75001

TAX EXEMPT NUMBER: 17513335558

SUBJECT TO TERMS & CONDITIONS CONTAINED ON BOTH SIDES
 THE P.O. NUMBER MUST APPEAR ON ALL INVOICES, DELIVERY TICKETS, ETC.

PURCHASE ORDER

No.	046895
ORDER DATE	08/14/97
1 of 1	08/14/97
REQUIRED DELIVERY DATE	

DELIVERY LOCATION:

(SC) ADDISON SERVICE CENTER
 16801 WESTGROVE
 DALLAS, TX 75248

ENDORSEE: BOLLEN RESOURCES INC
 5706 16520 WESTGROVE DR
 DALLAS, TX 75248
 Attn: HARMEN BOLLEN

ID NO.	REQUISITION	REQUISITIONER	TERMS - NET 30	BLANKET ORDER EXPIRES	F.O.B. DESTINATION
-27		131CJ			DESTINATION

REMARKS: ORDER 1: CITY COUNCIL APPROVED 8-12-97 USER 2: DIR PUB WORKS APPROVED-PHONE

ITEM	QUANTITY	UNIT	DESCRIPTION	UNIT PRICE	EXTENDED AMOUNT
1	40	EA	ADAPTER PLATES	60.0000	2,400.00
2	60	EA	LAMPS 175 MH FROSTED, MED BASE	35.9200	2,149.20
***** MEMO ACCOUNTING INFORMATION ONLY *****					
GENERAL LEDGER ACCOUNT NUMBER				DISTRIBUTION	
41 000 58270 65300 000				4,549.20	

14684 CLAIM # 85317

Cheryl Johnson
 PURCHASING MANAGER'S SIGNATURE

John Bogatz
 RECEIVED BY

John Bogatz
 AUTHORIZED SIGNATURE

SUB TOTAL	4,549.20
FREIGHT	0.00
TOTAL	4,549.20

CHECK REQUIRED IN ADVANCE

DELIVERY/ PARTIAL FINAL

DELIVERY DATE 9/24/97



TOWN OF ADDISON

MAIL ALL INVOICES TO:
 Accounts Payable
 P.O. Box 144
 Addison, Texas 75001

TAX EXEMPT NUMBER: 17513335558

SUBJECT TO TERMS & CONDITIONS CONTAINED ON BOTH SIDES
 THE P.O. NUMBER MUST APPEAR ON ALL INVOICES, DELIVERY TICKETS, ETC.

PURCHASE ORDER

No.	046897
ORDER DATE	08/14/97
1 of 1	08/14/97
REQUIRED DELIVERY DATE	

DELIVERY LOCATION:

(SC) ADDISON SERVICE CENTER
 16901 WESTGROVE
 DALLAS, TX 75248

NDOR BEGA/JS
 707 C/O BOLLEN RESOURCES
 16520 WESTGROVE DR
 DALLAS, TX 75248

NO.	REQUISITION	REQUISITIONER	TERMS - NET 30	BLANKET ORDER EXPIRES	F.O.B. DESTINATION
27		13103			DESTINATION

MENTS
 R 1: CITY COUNCIL APPROVED 8-12-97 USER 2: DIR PUB WORKS APPROVED-PHONE

M	QUANTITY	UNIT	DESCRIPTION	UNIT PRICE	EXTENDED AMOUNT
	55	EA	B9801MH POLE TOP FIXTURE, 240V-HPE 1-175W ED-17MH-LAMP NOT INCLUDED BEGA TEXTURED BLACK	884.0000	48,620.00
	55	EA	1506H, TAPERED ROUND POLE WITH HINGED BASE 15'8" IN HEIGHT, BEGA TEXTURED BLACK	711.0000	39,105.00
***** MEMO ACCOUNTING INFORMATION ONLY *****					
GENERAL LEDGER ACCOUNT NUMBER					
			41 000 58270 65300 000	87.725.00	

14683 CLAIM # 85318

Clyde Robinson
 PURCHASING MANAGER'S SIGNATURE
 RECEIVED BY *amh*
John Bengt
 AUTHORIZED SIGNATURE

SUB TOTAL	87,725.00
	0.00
FREIGHT	0.00
TOTAL	87,725.00

CHECK REQUIRED IN ADVANCE
 DELIVERY/ PARTIAL FINAL
 DELIVERY DATE 9/24/97

Shipper's #

Carrier

Agent's No.

RECEIVED, subject to the classifications and tariffs in effect on the date of the issue of this Bill of Lading.

at Sept. 23 1997 from Bollen Resources

The property described below, in apparent good order, except as noted (contents and condition of contents of packages unknown) marked, consigned and destined as shown below, which said company (the word company being understood throughout this contract as meaning any person or corporation in possession of the property under the contract) agrees to carry to its usual place of delivery at said destination, if on its own railroad, water line, highway route or routes, or when the territory of its highway operations, otherwise to deliver to another carrier on the route to said destination. It is mutually agreed, as to each carrier of all or any of said property over all or any portion of said route to destination, and as to each party of any term interested in all or any of said property, that every service to be performed hereunder shall be subject to all the conditions not prohibited by law, whether printed or written, herein contained, including the conditions on back hereof, which are hereby agreed to by the shipper and accepted for himself and his assignee.

(Mail or street address of consignee—For purposes of notification only.)

Consigned to Addison Service Center 16801 Westgrove Dr.

Destination DALLAS State of Tx. Zip Code 75248 County of DALLAS

Routing _____ Delivering Carrier _____ Vehicle or Car Initial _____ No. _____

Collect On Delivery \$ _____ and remit to: TOWN of Addison - PO# 046898

C. O. D. charge to be paid by Shipper Consignee

Subject to Section 7 of conditions, if this shipment is to be delivered to the consignee without recourse on the consignor, the consignor shall sign the following statements:

The carrier shall not make delivery of this shipment without payment of freight and all other lawful charges.

(Signature of Consignor.)

If charges are to be prepaid, write or stamp here, "TO BE PREPAID."

Prepaid

Received \$ _____ to apply to prepayment of the charges on the property described hereon.

Agent or Cashier

Per _____ (the signature here acknowledges only the amount prepaid.)

Charges Advanced:

\$ _____

Street City State

No. Packages	Description of Articles, Special Marks, and Exceptions	Weight (Sub. to Car.)	Class or Rate	Check Column
<u>30 ea.</u>	<u>Adapter PLATES</u>			
<u>5</u>	<u>AT JOBSITE</u>			

If the shipment moves between two ports by a carrier by water, the law requires that the bill of lading shall state whether it is "carrier's or shipper's weight." NOTE—Where the rate is dependent on weight, shippers are required to state specifically in writing the agreed or declared value of the property.

The declared value of the property is hereby specifically stated by this shipper to be not exceeding _____ per _____

[Signature]

Shipper, Per _____

Agent, Per _____

1

Permanent post-office address of shipper, _____

(This Bill of Lading is to be signed by the shipper and agent of the carrier issuing same.)

Bill of Lading

Shipper's #

Carrier

Agent's No.

RECEIVED, subject to the classifications and tariffs in effect on the date of the issue of this Bill of Lading,

at September 23 1997 from Bollen Resources

the property described below, in apparent good order, except as noted (contents and condition of contents of packages unknown) marked, consigned and destined as shown below, which said company (the word company being understood throughout this contract as meaning any person or corporation in possession of the property under the contract) agrees to carry to its usual place of delivery at said destination, if on its own railroad, water line, highway route or route, or within the territory of its highway agent, or otherwise to deliver to another carrier on the route to said destination. It is mutually agreed, as to each carrier of all or any of said property over all or any portion of said route to destination, and as to each party at any time interested in all or any of said property, that every service to be performed hereunder shall be subject to all the conditions not prohibited by law, whether printed or written, herein contained, including the conditions on back hereof, which are hereby agreed to by the shipper and accepted for himself and his assigns.

Consigned to Addison Service Center 16801 Westgrove Dr. (Mail or street address of consignee—For purposes of notification only.)

Destination DALLAS State of Tx. Zip Code 75248 County of DALLAS

Routing _____ Delivering _____ Vehicle _____
Carrier _____ or Car Initial _____ No. _____

Collect On Delivery

\$ _____ and remit to: TOWN OF Addison PO# 046898

C. O. D. charge to be paid by { Shipper
Consignee

No. Packages	Description of Articles, Special Marks, and Exceptions	Weight (Sub. to Cor.)	Class or Rate	Check Column
3	CARTONS WITH 12 LAMPS EACH = (36)			
1	CARTON WITH 21 LAMPS			
	TOTAL OF 57 LAMPS			
	+ 3 LAMPS ALREADY IN FIXTURES AT JOB SITE			
	60 LAMPS ORDERED			

Subject to Section 7 of conditions, if this shipment is to be delivered to the consignee without recourse on the consignor, the consignor shall sign the following statements:
The carrier shall not make delivery of this shipment without payment of freight and all other lawful charges.

(Signature of Consignor.)

If charges are to be prepaid, write or stamp here, "TO BE PREPAID"

Prepaid

Received \$ _____ to apply to prepayment of the charges on the property described hereon.

Agent or Cashier

Per _____ (the signature here acknowledges only the amount Prepaid.)

Charges Advanced: \$ _____

If the shipment moves between two ports by a carrier by water, the law requires that the bill of lading shall state whether it is "carrier's or shipper's weight." NOTE—Where the rate is dependent on weight, shippers are required to state specifically in writing the agreed or declared value of the property.
The _____ declared value of the property is hereby specifically stated by the shipper to be not exceeding per _____

Shipper, Per _____

Agent, Per _____

1

Permanent post-office address of shipper, _____

(This Bill of Lading is to be signed by the shipper and agent of the carrier issuing same.)

Bill of Lading

BEGA 1005 Mark Ave., Carpinteria, CA 93013
 (805) 684-0533 FAX (805) 684-6682

DATE 10/14/97 PAGE 1

ACKNOWLEDGEMENT

THIS IS A FAXED ACKNOWLEDGEMENT
 NO COPY WILL BE MAILED
 PLEASE CHECK FOR ACCURACY

SHIP TO: ADDISON SERVICE CENTER
 16801 WESTGROVE DR.
 ADDISON TX 75248
 USA

EXPORT CURRENCY
 N

SOLD TO: TOWN OF ADDISON
 ACCOUNTS PAYABLE
 PO BOX 144
 ADDISON TX 75001
 USA

TERMS
 NET 30 DAYS

CUSTOMER	ORDER	SALESREP	P.O.NUMBER	P.O.REV
1 14186000	CO 71676	10	46897	

SHIP VIA
 BEST PREPAID 10

ITEM NUMBER/DESCRIPTION	U/M	QUANTITY/PRICE	NET SALES AMOUNT
B9801 SINGLE POLE TOP LUMINAIRE WIDE BEAM DISTRIBUTION TO BE MODIFIED AS LISTED BELOW: Est Shipping Week of 10/10/97 Warehouse 1	EA	40.000 884.000	35,360.00

NET SALES	.00	TRADE DISCOUNT	.00
MISC. CHARGES	.00	TERMS DISCOUNT	.00
FREIGHT	.00		
TAXES	.00		
TOTAL AMOUNT			.00

TOWN OF ADDISON
SPECIFICATIONS AND BID FORM FOR
ADDISON CIRCLE PHASE I
STREET LIGHT POLE SYSTEMS

JULY 1, 1997

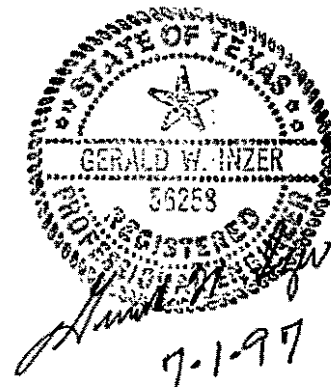

INVITATION TO BID

The Town of Addison is accepting bids from all interested parties for street light pole systems.

Bid No. 97-27

Bid Name: Addison Circle Phase I Street Light Pole Systems

Bids Opened: July 25, 1997, 2:00 PM
Office of the Purchasing Manager
Addison Finance Building
5350 Belt Line Road
Addison, Texas 75240

For questions concerning the bidding procedure contact Purchasing at (972) 450-7091. Questions concerning specifications or technical information may be directed to Mr. John Baumgartner, P.E. at (972) 450-2871.

INSTRUCTIONS TO BIDDERS

1.0 RECEIPT AND PREPARATION OF THE BID

- 1.1 Bids will be received by the Purchasing Department of the Town of Addison until the time and date stated in the INVITATION TO BID, at the Office of the Purchasing Agent at 5350 Belt Line Road, Addison, Texas 75240, at which time they will be opened and read aloud.

Bids submitted after this closing time will not be accepted and will be returned unopened.

Unsigned bids will not be considered.

- 1.2 Each bid shall be enclosed in a sealed envelope, addressed to the Purchasing Manager, Town of Addison, 5350 Belt Line Road, Addison, Texas 75240.

Bids must be labeled in the lower left hand corner with the Bid Number and Bid Name.

Bidders must also include their company name and address on the outside of the envelope.

- 1.3 Bidders are responsible for making certain bids are delivered to the purchasing department. Mailing of a bid does not insure that the bid will be delivered on time or delivered at all. If a bidder does not hand deliver the bid, it is suggested that he/she use some sort of delivery service that provides a receipt.
- 1.4 Bids may be withdrawn prior to the above scheduled time set for closing of the bids. Any bid received after the time and date specified shall not be considered.
- 1.5 The Town of Addison reserves the right to postpone the date and time for opening bids, through an addendum.

2.0 ADDENDA AND EXPLANATIONS

- 2.1 Bidders having any questions regarding the true meaning of the specifications or terms and conditions shall submit these questions to the Purchasing Manger. Any and all interpretations or supplemental instructions, which, if issued, will be sent to all prospective bidders. A copy of all addenda issued must be signed and returned with your bid.

7.2 Award will be based upon an analysis of the following criteria:

- a. Price.
- b. Quality of materials bid.
- c. Bidders ability to produce the goods or services requested, in a timely manner.
- d. Performance on similar contracts.
- e. Bidder's past responsiveness, if applicable.
- f. Bidder's perceived understanding of the purchaser's needs.

7.3 To demonstrate bidder's qualifications to perform the work, each bidder must submit with their bid, a minimum of three (3) customer references, including company name, telephone number and individual to contact. Use governmental agencies as references, if available.

8.0 RESOLUTION OF DISPUTES

The parties hereby covenant and agree that in the event of any controversy, dispute, or claim of whatever nature arising out of, in connection with or in relation to the interpretation, performance or breach of this agreement, including but not limited to any claims based on contract, tort or statute before filing a lawsuit the parties agree to submit the matter to Alternative Dispute Resolution pursuant to the laws of the State of Texas. The parties shall select a third party arbitrator or mediator from the current list of neutrals on file with the Alternative Dispute Resolution Administrator of the Dallas County District Courts. All forms of Alternative Dispute Resolution may be used except binding arbitration. The proceedings shall be conducted in accordance with the laws of the State of Texas.

9.0 NON DISCRIMINATION POLICY

It is the policy of the Town of Addison to afford all people an equal opportunity to bid on any contract bidding let by the Town.

The Town of Addison has a policy that prohibits discrimination against any person because of race, color, sex, or national origin, in the award of performance of any contract.

The Town of Addison will require its employees, agents, and contractors to adhere to this policy.

TOWN OF ADDISON

SPECIFICATIONS FOR STREET LIGHT POLE SYSTEMS

1.0 GENERAL:

A Street Light Pole System shall consist of a pole with installation hardware, anchor bolts, ballast, fixture, lamp, accessories, etc. for complete installation as detailed on the plans.

2.0 FABRICATOR:

Fabricator shall be Certified by the governing agencies of Aluminum Construction and have UL listed materials. Proof of this certification will be required with the bid submittal to assure that the fabricator has the personnel, organization, experience, procedures, knowledge, equipment, capability and commitment to fabricate quality Lighting Pole Structures.

3.0 DESIGN:

Pole shaft, base plate, anchor bolts, mast arm, base plate, and structural connecting hardware, shall be designed in accordance with the requirements of the 1985 AASHTO "Standard Specifications for Structural Supports for Highway Signs, Luminaries, and Traffic Signals". Loading shall be based on an isotach wind velocity of 80 mph. Analysis shall include varying wind directions 360 degrees around the pole in increments of 5 degrees. Calculations and detail drawings shall be submitted for verification of compliance to these specifications.

4.0 POLE/TUBULAR MEMBERS:

The tubular member's cross section shall be round and shall have a constant linear taper of approximately 0.14 in/ft. It shall be fabricated from United States produced high purity aluminum alloy. Die cast aluminum construction is cast under extremely high pressure to ensure greater strength, fine detail of parts, close tolerance fit with no porosity and maximum corrosion resistance. Tubular members 50-feet or less in length, shall be of the same thickness throughout the length of the entire member.

Pole Shafts Each pole shall be provided with a pole cap secured in place with set screw or other suitable fasteners. A "J-hook" wire support and grounding attachment shall be provided in each pole shaft.

Step 5 Prime coating. Electrostatic powder coat is applied and fused on at a temperature of 220°C, which provides a thick prime coat on all areas of the aluminum. The powder coat process is particularly resistant to scratching and abrasion.

Step 6 First color coat. A smooth spray coat of acrylic enamel is applied.

Step 7 Second color coat. A textured spray coat of acrylic enamel is applied over the smooth color undercoat.

Step 8 Tempering. Both color coats are "baked on" at a temperature of 120°C.

10.0 FIXTURE ASSEMBLY:

- Molded Gaskets - gaskets are molded O-ring or 'U' type of high temperature silicone or neoprene rubber.
- Stainless Steel Fasteners - are threaded into stainless steel inserts in the castings which prevents 'freeze-up' due to electrolysis between dissimilar metals. Fasteners are socket head stainless steel, metric screws which are semi-tamperproof.
- Lampholders are porcelain with nickel plated, copper screw shells.

11.0 BALLAST:

Provide 240V, 1PH, zero degrees ballast. Premium quality ballast on removal electrical gear tray. Provide double fusing of 240V circuit to ballast.

12.0 LAMP:

175W Metal Halide

13.0 LENS:

Custom designed pressed crystal glass.

14.0 REFLECTOR:

Spun aluminum with specular finish.

15.0 PHOTOMETRIC PERFORMANCE:

Provide a photometric report of proposed light fixture.

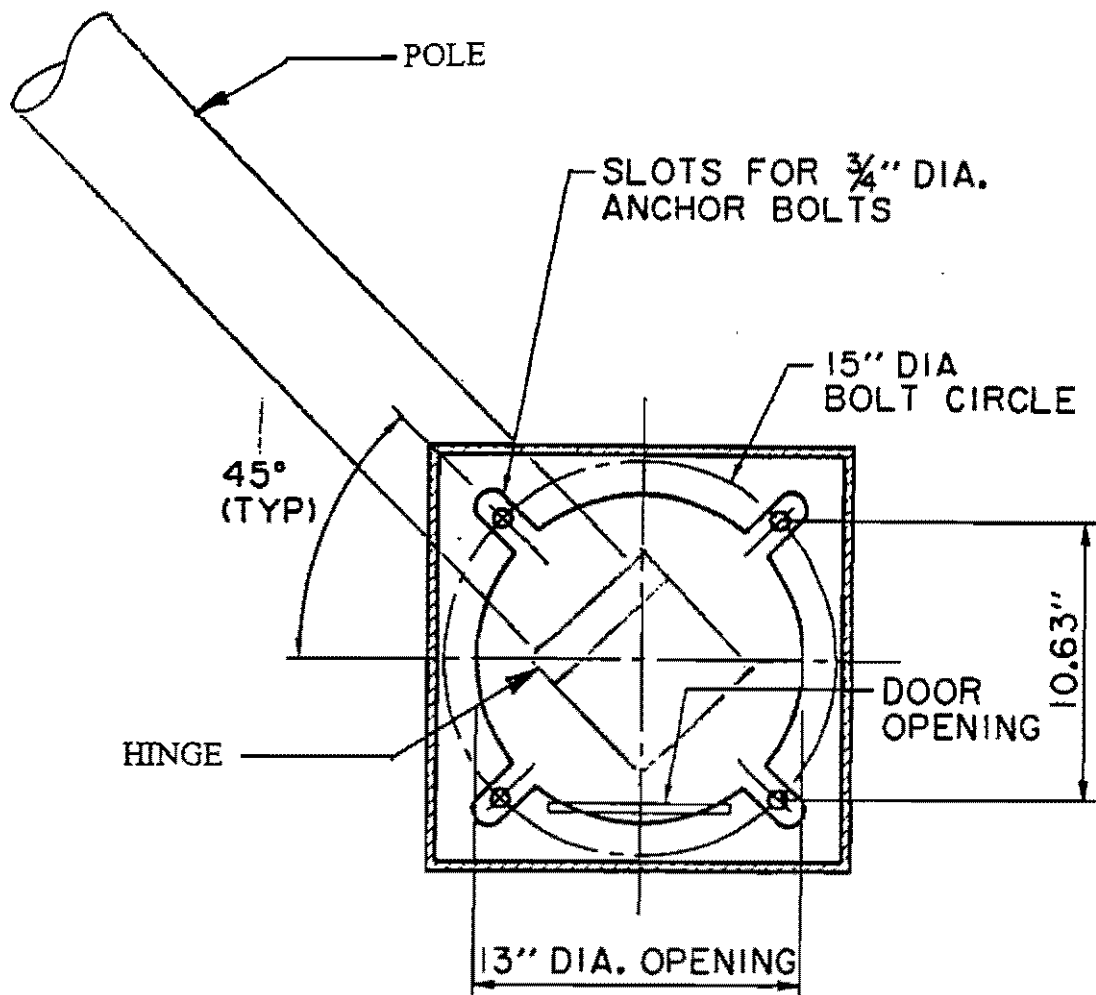

POLE ANCHOR DETAIL

N.T.S.

NOTES:

1. A CUSTOM BASE PLATE IS REQUIRED FOR THE POLES. THIS DETAIL IS PROVIDED TO SHOW THE EXISTING BOLT PATTERN WHICH IS TO BE MET FOR THE CUSTOM BASE PLATE. THE CUSTOM BASE PLATE WILL VARY FROM THIS DETAIL AS REQUIRED FOR THE POLE.
2. IN LIEU OF DOOR OPENING SHOWN, A HINGED POLE IS REQUIRED. THE POLE IS TO HINGE 45° FROM MAIN AXIS. PROVIDE SPLIT ROUND COVER OVER THE CUSTOM BASE PLATE WITH FINISH TO MATCH POLE.
3. ALL POLE BASE DETAILS MUST BE CONFIRMED IN WRITING WITH THE OWNER PRIOR TO FABRICATION. AN ALTERNATE BOLT PATTERN MAY BE USED FOR SOME POLES AT OPTION OF OWNER.

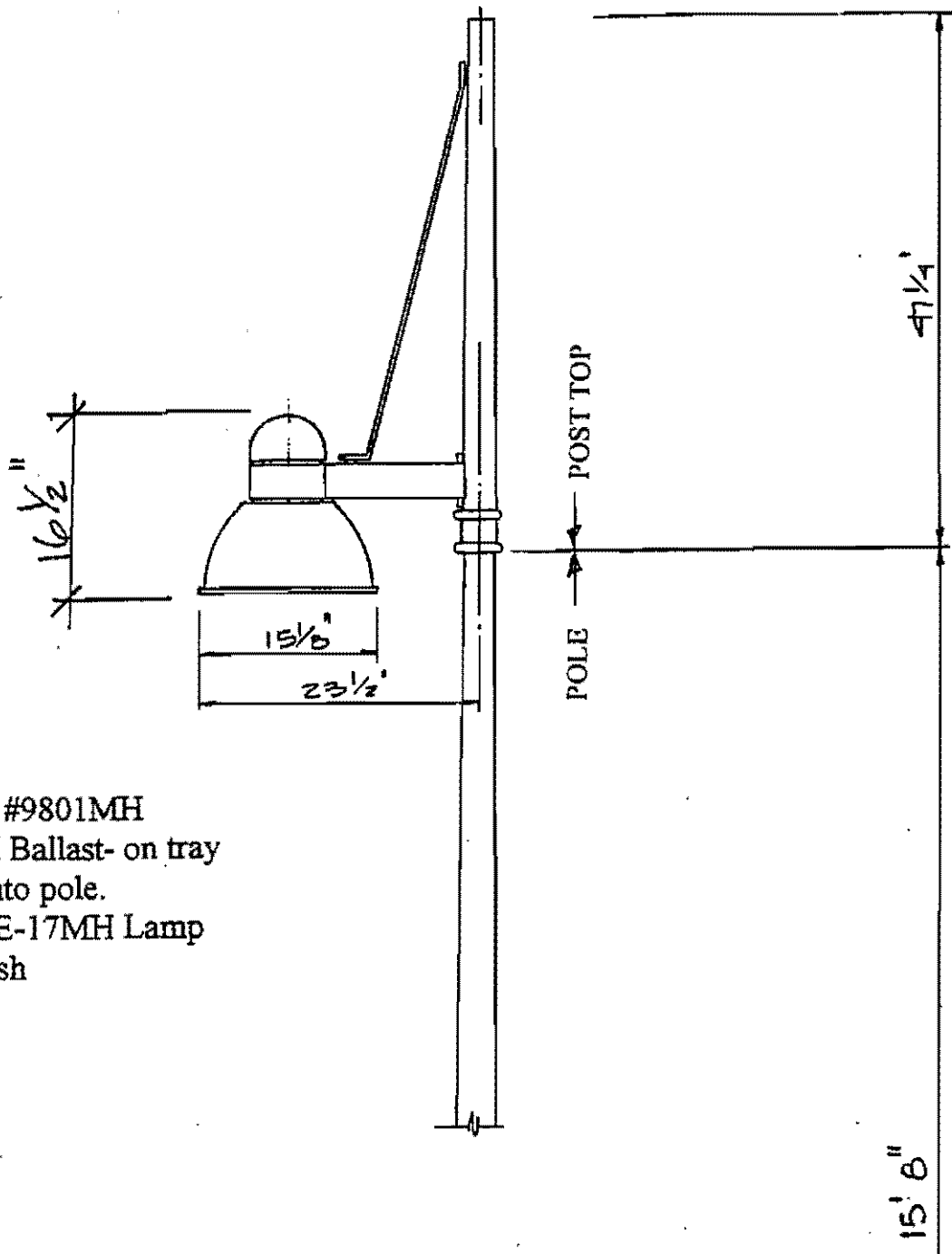

Notes:

1. Luminaire #9801MH
2. 175W MH Ballast- on tray recessed into pole.
3. (1) 175W E-17MH Lamp
4. Black Finish

POST TOP DETAIL

N.T.S.

BID FORM

**ADDISON CIRCLE PHASE I
STREET LIGHT POLE SYSTEMS
BID NO. 97-27**

Company Name: _____

Full Mailing

Address: _____
Number & Street/P.O. City State Zip

Phone Number: () _____ Fax: () _____

I have reviewed, read, and will abide by all pages of these specifications. I am a legal agent of the above named company and am fully authorized to sign this bid. Affiant further states that Bidder has not paid, given, or donated or agreed to pay, give or donate to any officer or employee of the Town of Addison any money or other thing of value, either directly or indirectly, in award of the bid.

Authorized Signature

Date

Print Name

Title

ACKNOWLEDGEMENT OF ADDENDA:

The Bidder acknowledges receipt of the following addenda, if addenda were issued and received:

Addendum No. 1 _____

Addendum No. 2 _____

Addendum No. 3 _____

**BID SCHEDULE
TRAFFIC SIGNAL POLE SYSTEMS
BID NO. 97-22**

Note: Prices must be shown in words and figures for each item listed in this proposal. In the event of discrepancy, the words shall control.

ITEM NO.	ESTIM. QTY.	UNIT	DESCRIPTION & UNIT PRICE IN WORDS	UNIT PRICE \$	AMOUNT BID \$
1	55		15'-8" light pole, anchor base and all accessories. Complete in Place, for the Sum of _____ _____ Dollars and Cents per unit.		
2	60		175 W metal halide lamps. Complete in Place, for the Sum of _____ _____ Dollars and Cents per unit.		
3	1		Delivery of Street Light Pole systems for Complete in Place, for the Sum of _____ _____ Dollars and Cents per unit.		

TOTAL AMOUNT BID FOR ITEMS 1 THROUGH 3 \$ _____

DELIVERY FROM DATE OF ORDER: _____ DAYS

REFERENCES:

<u>CUSTOMER NUMBER</u>	<u>CONTACT NAME</u>	<u>PHONE</u>
----------------------------	---------------------	--------------

MANUFACTURER AND CATALOG NUMBERS OF PROPOSED POLES AND FIXTURES:

HUITT-ZOLLARS

*XTRA copy
of Mike's
INFO*

Dallas • Fort Worth • Houston • El Paso • Phoenix • Tustin • Ontario • San Clemente

FACSIMILE TRANSMITTAL

Date: 2/10/97

Fax No.: 972-770-5129

H-Z Proj. No. 01251301

No. of Pages: 2
(Including Cover Sheet)

TO: Columbus Realty Trust
ATTN: BRYANT HAIN

URGENT For Your Review Please Call Upon Receipt Orig. To Follow By Mail

RE: ADDISON CIRCLE I

STREET LIGHT COST COMPARISON.

FROM: David Meyers

SENT BY: _____ TIME: _____ DATE: _____

If you had any problems receiving the Facsimile Transmittal, please contact Ms. Janet Willis or the individual listed above at (214) 871-3311. Thank you.

**ADDISON CIRCLE PHASE I
PUBLIC INFRASTRUCTURE
STREET LIGHT COST COMPARISON
02/10/97**

	TEXAN STYLE 14 FOOT POLE	BEGA 14 FOOT POLE	COST SAVINGS
COST OF POLE AND FIXTURE INSTALLED	\$2,156	\$1,650	\$506
COST OF WIRE PER POLE	\$100	\$160	\$0
COST FOR FOUNDATION AND SQUARE CAP	\$486	\$486	\$0
TUE CREDIT FOR BASIC LIGHT POLE AND FIXTURE	<u>(\$323)</u>	<u>\$0</u>	<u>(\$323)</u>
TOTALS	\$2,479	\$2,296	\$183

55 POLES REMAINING IN PROJECT FOR SAVINGS OF

\$10,065

1. ASSUMES FOUNDATION AND ELECTRICAL WIRING IS THE SAME FOR EACH STYLE POLE.
2. ASSUMES WATTAGE OF BULB IS THE SAME.
3. TUE DOES NOT PROVIDE DESIGN OR MAINTENANCE FOR NON-TUE STANDARD POLE AND FIXTURE.
THE BEGA POLE WILL REQUIRE AN ELECTRICAL DESIGN.
4. BEGA INSTALLED COST BASED ON \$1,300 MATERIALS PLUS 25% FOR INSTALLATION.
5. T.U.E. DOES NOT DESIGN TO NEC. IT IS POSSIBLE THAT FOLLOWING CODE COULD INCREASE WIRE COST.
6. WIRE COST IS FROM T.U.E.; INDEPENDENT CONTRACTOR COST MAY BE HIGHER.
7. PERHAPS THE CONTRACTOR COULD DO A DESIGN-BUILD TO SAVE MONEY ON DESIGN.

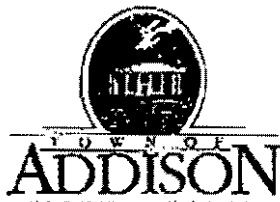
**PUBLIC WORKS DEPARTMENT**

(972) 450-2871

Post Office Box 144 Addison, Texas 75001

16801 Westgrove

MEMORANDUM

August 4, 1997

To: Ron Whitehead
City Manager

From: John R. Baumgartner, P.E.
Director of Public Works

Re: Addison Circle Phase I Street Lighting

Attached is a bid from Bolen Resources to supply Bega light fixtures for us in the Addison Circle Project.

The light fixtures represent a portion of the total cost for the project, and the following table identifies other expenses and funding:

Costs:

1. Engineering Electrical Circuit and Developing Bid Documents	\$5,600.00
2. Provide Bega fixtures	\$93,174.20
3. Install Bega fixtures (estimate)	\$23,500.00
4. Construct lighting circuit (estimate)	\$15,000.00
5. TU Electric re-stocking fee to Texan light fixtures	\$39,907.75 ★
TOTAL COST	\$177,181.95

Funding:

1. Allowance from Addison Circle Phase I infrastructure:	\$97,149.00
2. Addison Circle offsite improvements:	\$80,032.95
TOTAL FUNDS AVAILABLE	\$177,181.915

Staff recommends that the Council award the contract to supply street lights to Addison Circle Phase I to Bollen Industries, Inc. and to authorize staff to proceed with the necessary steps to implement a design/installation change from the Texan lights to the Bega light fixtures.



TOWN OF ADDISON

MAIL ALL INVOICES TO:
 Accounts Payable
 P.O. Box 144
 Addison, Texas 75001

TAX EXEMPT NUMBER: 17513335558

SUBJECT TO TERMS & CONDITIONS CONTAINED ON BOTH SIDES
 THE P.O. NUMBER MUST APPEAR ON ALL INVOICES, DELIVERY TICKETS, ETC.

PURCHASE ORDER

No. 046898

ORDER DATE 08/14/97

1 of 1 08/14/97

REQUIRED DELIVERY DATE

DELIVERY LOCATION:

(SC) ADDISON SERVICE CENTER
 16801 WESTGROVE
 DALLAS, TX 75248

ENDORSEE: BOLLEN RESOURCES INC
 5706 16520 WESTGROVE DR
 DALLAS, TX 75248
 Attn: HARMEN BOLLEN

Q NO	REQUISITION	REQUISITIONER	TERMS	BLANKET ORDER EXPIRES	F.O.B. DESTINATION
-27		131CJ	NET 30		DESTINATION

APPROVALS:
 USER 1: CITY COUNCIL APPROVED 8-12-97 USER 2: DIR PUB WORKS APPROVED-PHONE

ITEM	QUANTITY	UNIT	DESCRIPTION	UNIT PRICE	EXTENDED AMOUNT
1	40	EA	ADAPTER PLATES	60.0000	2,400.00
2	60	EA	LAMPS 175 MH FROSTED, MED BASE	35.9200	2,149.20

MEMO ACCOUNTING INFORMATION ONLY				DISTRIBUTION	
GENERAL LEDGER ACCOUNT NUMBER					
41 000 58270 65300 000				4,549.20	

14584 CLAIM # 85317

[Signature]
 PURCHASING MANAGER'S SIGNATURE

[Signature]
 RECEIVED BY

[Signature]
 AUTHORIZED SIGNATURE

SUB TOTAL	4,549.20
	0.00
FREIGHT	0.00
TOTAL	4,549.20

CHECK REQUIRED IN ADVANCE
 DELIVERY/ PARTIAL FINAL
 DELIVERY DATE 9/24/97



TOWN OF ADDISON

MAIL ALL INVOICES TO:
 Accounts Payable
 P.O. Box 144
 Addison, Texas 75001

TAX EXEMPT NUMBER: 17513335568

SUBJECT TO TERMS & CONDITIONS CONTAINED ON BOTH SIDES
 THE P.O. NUMBER MUST APPEAR ON ALL INVOICES, DELIVERY TICKETS, ETC.

PURCHASE ORDER

No.	046897
ORDER DATE	08/14/97
1 of 1	08/14/97
REQUIRED DELIVERY DATE	

DELIVERY LOCATION:

(SC) ADDISON SERVICE CENTER
 16901 WESTGROVE
 DALLAS, TX 75249

DOR BEGA/US
 707 C/O BOLLEN RESOURCES
 16520 WESTGROVE DR
 DALLAS, TX 75248

NO.	REQUISITION	REQUISITIONER	TERMS	BLANKET ORDER EXPIRES	F.O.B. DESTINATION
27		131CJ	NET 30		DESTINATION

ENTR 1: CITY COUNCIL APPROVED 8-12-97 USER 2: DIR PUB WORKS APPROVED-PHONE

QUANTITY	UNIT	DESCRIPTION	UNIT PRICE	EXTENDED AMOUNT
55	EA	B980+MH POLE TOP FIXTURE, 240V-HPE 1-175W ED-17MH-LAMP NOT INCLUDED BEGA TEXTURED BLACK	884.0000	48,620.00
55	EA	1508H, TAPERED ROUND POLE WITH HINGED BASE 15'8" IN HEIGHT, BEGA TEXTURED BLACK	711.0000	39,105.00
***** MEMO ACCOUNTING INFORMATION ONLY *****				
GENERAL LEDGER ACCOUNT NUMBER:			DISTRIBUTION	
41 000 58270 65300 000			87.725.00	

14683 CLAIM # 85318

CHECK REQUIRED IN ADVANCE

DELIVERY/ PARTIAL FINAL

DELIVERY DATE 9/24/97

Clyde Robinson
 PURCHASING MANAGER'S SIGNATURE

amh
 RECEIVED BY

John B. ...
 AUTHORIZED SIGNATURE

SUB TOTAL	87,725.00
	0.00
FREIGHT	0.00
TOTAL	87,725.00

Carrier

Agent's No.

RECEIVED, subject to the classifications and tariffs in effect on the date of the issue of this Bill of Lading,

at Sept. 23 1997 from Bollen Resources

The property described below, in apparent good order, except as noted (contents and condition of packages unknown) marked, cartoned and destined as shown below, which said company (the word company being understood throughout this contract as meaning any person or corporation in possession of the property under the contract) agrees to carry to its usual place of delivery at said destination, if on its own railroad, water line, highway route or route, or within the territory of its highway operations, otherwise to deliver to another carrier on the route to said destination. It is mutually agreed, as to each carrier of all or any part of said property over all or any portion of said route to destination, and as to each party at any time interested in all or any of said property, that every service to be performed hereunder shall be subject to all the conditions not prohibited by law, whether printed or written, herein contained, including the conditions on back hereof, which are hereby agreed to by the shipper and accepted for himself and his assigns.

Consigned to Addison Service Center (Mall or street address of consignee—For purposes of notification only.) 16801 Westgrove Dr.

Destination DALLAS State of Tx. Zip Code 75248 County of DALLAS

Routing _____ Delivering Carrier _____ Vehicle or Car Initial _____ No. _____

Collect On Delivery \$ _____ and remit to: TOWN of Addison - PO# 046898

C. O. D. charge to be paid by { Shipper Consignee

Subject to Section 7 of conditions, if this shipment is to be delivered to the consignee without recourse on the consignor, the consignor shall sign the following statement:
The carrier shall not make delivery of this shipment without payment of freight and all other lawful charges.

(Signature of Consignor.)

If charges are to be prepaid, write or stamp here, "TO BE PREPAID."
Prepaid

Received \$ _____ to apply to prepayment of the charges on the property described hereon.

Agent or Cashier

Per _____ (the signature here acknowledges only the amount Prepaid.)

Charges Advanced: \$ _____

No. Packages	Description of Articles, Special Marks, and Exceptions	Weight (Sub. to Car.)	Class or Rate	Check Column
<u>30</u>	<u>CR: Adapter PLATES</u>			
<u>5</u>	<u>AT JOBSITE</u>			

If the shipment moves between two ports by a carrier by water, the law requires that the bill of lading shall state whether it is "carrier's or shipper's weight." NOTE—Where the rate is dependent on weight, shippers are required to state specifically in writing the agreed or declared value of the property.
Declared or declared value of the property is hereby specifically stated by the shipper to be not exceeding per

Shipper, Per _____ Agent, Per _____ **1**

Permanent post-office address of shipper.

(This Bill of Lading is to be signed by the shipper and agent of the carrier issuing same.)

Bill of Lading

Shipper's #

Carrier

Agent's No.

RECEIVED, subject to the classifications and tariffs in effect on the date of the issue of this Bill of Lading.

at September 23 1997 from Bollen Resources

the property described below, in apparent good order, except as noted (contents and condition of contents of packages unknown), marked, consigned and destined as shown below, which said company (the word company being understood throughout this contract as meaning any person or corporation in possession of the property under the contract) agrees to carry to its usual place of delivery at said destination, if on its own railroad, with the following exceptions, otherwise to deliver to another carrier on the route to said destination if it mutually agrees, as to each carrier of all or any of said property over all or any portion of said route to destination, and as to each party at any time interested in all or any of said property, that every service to be performed hereunder shall be subject to all the conditions not prohibited by law, whether printed or written, herein contained, including the conditions on back hereof, which are hereby agreed to by the shipper and accepted for himself and his assigns.

Consigned to Addison Service Center 16801 Westgrove Dr. (Mail or street address of consignee—For purposes of notification only.)

Destination DALLAS State of TX Zip Code 75248 County of DALLAS

Routing _____ Delivering Carrier _____ Vehicle or Car Initial _____ No. _____

Collect On Delivery \$ _____ and remit to: TOWN OF Addison PO# 046898 C. O. D. charge to be paid by { Shipper Consignee

Street _____ City _____ State _____

No. Packages	Description of Articles, Special Marks, and Exceptions	Weight (Sub. to Cor.)	Class or Rate	Check Column
3	CARTONS WITH 12 LAMPS EACH = (36)			
1	CARTON WITH 21 LAMPS			
	Total of 57 LAMPS			
	+ 3 LAMPS ALREADY IN FIXTURES AT JOBSITE			
	60 LAMPS ORDERED			

Subject to Section 7 of conditions, if this shipment is to be delivered to the consignee without recourse on the consignor, the consignor shall sign the following statements:

The carrier shall not make delivery of this shipment without payment of freight and all other lawful charges.

(Signature of Consignor)

If charges are to be prepaid, write or stamp here, "TO BE PREPAID."

Prepaid

Received \$ _____ to apply to prepayment of the charges on the property described hereon.

Agent or Cashier

Per _____ (the signature here acknowledges only the amount prepaid.)

Charges Advanced:

\$ _____

When shipment moves between two ports by a carrier by water, the law requires that the bill of lading shall state whether it is "carrier's or shipper's weight." NOTE—Where the rate is dependent, shippers are required to state specifically in writing the agreed or declared value of the property.

The agreed or declared value of the property is hereby specifically stated by the shipper to be not exceeding 06 Oct per

Shipper, Per _____ Agent, Per _____ **1**

Permanent post-office address of shipper,

(This Bill of Lading is to be signed by the shipper and agent of the carrier issuing same.)

Bill of Lading

BEGA 1005 Mark Ave., Carpinteria, CA 93013
(805) 684-0533 FAX (805) 684-6682

DATE 10/14/97 PAGE 1

ACKNOWLEDGEMENT

THIS IS A FAXED ACKNOWLEDGEMENT
NO COPY WILL BE MAILED
PLEASE CHECK FOR ACCURACY

SHIP TO: ADDISON SERVICE CENTER
16801 WESTGROVE DR.
ADDISON TX 75248
USA

EXPORT CURRENCY
N

SOLD TO: TOWN OF ADDISON
ACCOUNTS PAYABLE
PO BOX 144
ADDISON TX 75001
USA

TERMS
NET 30 DAYS

CUSTOMER	ORDER	SALESREP	P.O.NUMBER	P.O.REV
1 14186000	CO 71676	10	46897	

SHIP VIA
BEST PREPAID 10

ITEM NUMBER/DESCRIPTION	UM	QUANTITY/PRICE	NET SALES AMOUNT
B9801 SINGLE POLE TOP LUMINAIRE WIDE BEAM DISTRIBUTION TO BE MODIFIED AS LISTED BELOW: Est Shipping Week of 10/10/97 Warehouse 1	EA	40.000 884.000	35,360.00

NET SALES	.00	TRADE DISCOUNT	.00
MISC. CHARGES	.00	TERMS DISCOUNT	.00
FREIGHT	.00		
TAXES	.00		
TOTAL AMOUNT			.00

TOWN OF ADDISON
SPECIFICATIONS AND BID FORM FOR
ADDISON CIRCLE PHASE I
STREET LIGHT POLE SYSTEMS

JULY 1, 1997

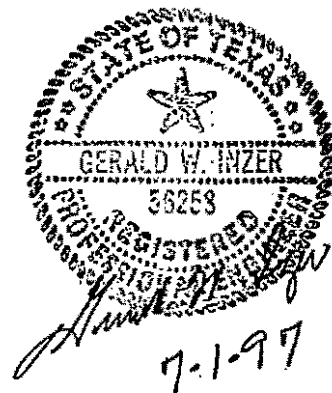

INVITATION TO BID

The Town of Addison is accepting bids from all interested parties for street light pole systems.

Bid No. 97-27

Bid Name: Addison Circle Phase I Street Light Pole Systems

Bids Opened: July 25, 1997, 2:00 PM
Office of the Purchasing Manager
Addison Finance Building
5350 Belt Line Road
Addison, Texas 75240

For questions concerning the bidding procedure contact Purchasing at (972) 450-7091. Questions concerning specifications or technical information may be directed to Mr. John Baumgartner, P.E. at (972) 450-2871.

INSTRUCTIONS TO BIDDERS

1.0 RECEIPT AND PREPARATION OF THE BID

- 1.1 Bids will be received by the Purchasing Department of the Town of Addison until the time and date stated in the INVITATION TO BID, at the Office of the Purchasing Agent at 5350 Belt Line Road, Addison, Texas 75240, at which time they will be opened and read aloud.

Bids submitted after this closing time will not be accepted and will be returned unopened.

Unsigned bids will not be considered.

- 1.2 Each bid shall be enclosed in a sealed envelope, addressed to the Purchasing Manager, Town of Addison, 5350 Belt Line Road, Addison, Texas 75240.

Bids must be labeled in the lower left hand corner with the Bid Number and Bid Name.

Bidders must also include their company name and address on the outside of the envelope.

- 1.3 Bidders are responsible for making certain bids are delivered to the purchasing department. Mailing of a bid does not insure that the bid will be delivered on time or delivered at all. If a bidder does not hand deliver the bid, it is suggested that he/she use some sort of delivery service that provides a receipt.
- 1.4 Bids may be withdrawn prior to the above scheduled time set for closing of the bids. Any bid received after the time and date specified shall not be considered.
- 1.5 The Town of Addison reserves the right to postpone the date and time for opening bids, through an addendum.

2.0 ADDENDA AND EXPLANATIONS

- 2.1 Bidders having any questions regarding the true meaning of the specifications or terms and conditions shall submit these questions to the Purchasing Manger. Any and all interpretations or supplemental instructions, which, if issued, will be sent to all prospective bidders. A copy of all addenda issued must be signed and returned with your bid.

7.2 Award will be based upon an analysis of the following criteria:

- a. Price.
- b. Quality of materials bid.
- c. Bidders ability to produce the goods or services requested, in a timely manner.
- d. Performance on similar contracts.
- e. Bidder's past responsiveness, if applicable.
- f. Bidder's perceived understanding of the purchaser's needs.

7.3 To demonstrate bidder's qualifications to perform the work, each bidder must submit with their bid, a minimum of three (3) customer references, including company name, telephone number and individual to contact. Use governmental agencies as references, if available.

8.0 RESOLUTION OF DISPUTES

The parties hereby covenant and agree that in the event of any controversy, dispute, or claim of whatever nature arising out of, in connection with or in relation to the interpretation, performance or breach of this agreement, including but not limited to any claims based on contract, tort or statute before filing a lawsuit the parties agree to submit the matter to Alternative Dispute Resolution pursuant to the laws of the State of Texas. The parties shall select a third party arbitrator or mediator from the current list of neutrals on file with the Alternative Dispute Resolution Administrator of the Dallas County District Courts. All forms of Alternative Dispute Resolution may be used except binding arbitration. The proceedings shall be conducted in accordance with the laws of the State of Texas.

9.0 NON DISCRIMINATION POLICY

It is the policy of the Town of Addison to afford all people an equal opportunity to bid on any contract bidding let by the Town.

The Town of Addison has a policy that prohibits discrimination against any person because of race, color, sex, or national origin, in the award of performance of any contract.

The Town of Addison will require its employees, agents, and contractors to adhere to this policy.

TOWN OF ADDISON

SPECIFICATIONS FOR STREET LIGHT POLE SYSTEMS

1.0 GENERAL:

A Street Light Pole System shall consist of a pole with installation hardware, anchor bolts, ballast, fixture, lamp, accessories, etc. for complete installation as detailed on the plans.

2.0 FABRICATOR:

Fabricator shall be Certified by the governing agencies of Aluminum Construction and have UL listed materials. Proof of this certification will be required with the bid submittal to assure that the fabricator has the personnel, organization, experience, procedures, knowledge, equipment, capability and commitment to fabricate quality Lighting Pole Structures.

3.0 DESIGN:

Pole shaft, base plate, anchor bolts, mast arm, base plate, and structural connecting hardware, shall be designed in accordance with the requirements of the 1985 AASHTO "Standard Specifications for Structural Supports for Highway Signs, Luminaries, and Traffic Signals". Loading shall be based on an isotach wind velocity of 80 mph. Analysis shall include varying wind directions 360 degrees around the pole in increments of 5 degrees. Calculations and detail drawings shall be submitted for verification of compliance to these specifications.

4.0 POLE/TUBULAR MEMBERS:

The tubular member's cross section shall be round and shall have a constant linear taper of approximately 0.14 in/ft. It shall be fabricated from United States produced high purity aluminum alloy. Die cast aluminum construction is cast under extremely high pressure to ensure greater strength, fine detail of parts, close tolerance fit with no porosity and maximum corrosion resistance. Tubular members 50-feet or less in length, shall be of the same thickness throughout the length of the entire member.

Pole Shafts Each pole shall be provided with a pole cap secured in place with set screw or other suitable fasteners. A "J-hook" wire support and grounding attachment shall be provided in each pole shaft.

Step 5 Prime coating. Electrostatic powder coat is applied and fused on at a temperature of 220°C, which provides a thick prime coat on all areas of the aluminum. The powder coat process is particularly resistant to scratching and abrasion.

Step 6 First color coat. A smooth spray coat of acrylic enamel is applied.

Step 7 Second color coat. A textured spray coat of acrylic enamel is applied over the smooth color undercoat.

Step 8 Tempering. Both color coats are "baked on" at a temperature of 120°C.

10.0 FIXTURE ASSEMBLY:

- Molded Gaskets - gaskets are molded O-ring or 'U' type of high temperature silicone or neoprene rubber.
- Stainless Steel Fasteners - are threaded into stainless steel inserts in the castings which prevents 'freeze-up' due to electrolysis between dissimilar metals. Fasteners are socket head stainless steel, metric screws which are semi-tamperproof.
- Lampholders are porcelain with nickel plated, copper screw shells.

11.0 BALLAST:

Provide 240V, 1PH, zero degrees ballast. Premium quality ballast on removal electrical gear tray. Provide double fusing of 240V circuit to ballast.

12.0 LAMP:

175W Metal Halide

13.0 LENS:

Custom designed pressed crystal glass.

14.0 REFLECTOR:

Spun aluminum with specular finish.

15.0 PHOTOMETRIC PERFORMANCE:

Provide a photometric report of proposed light fixture.

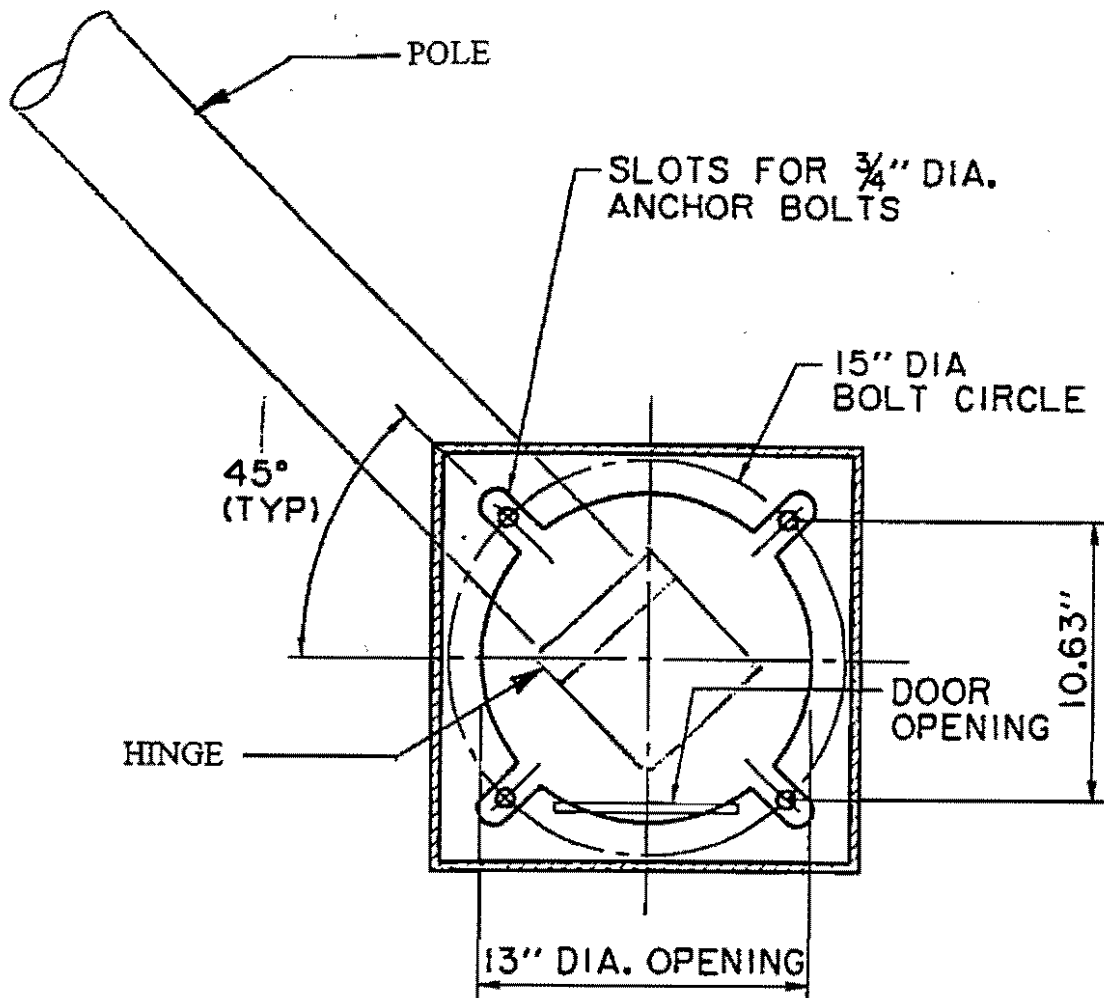

POLE ANCHOR DETAIL

N.T.S.

NOTES:

1. A CUSTOM BASE PLATE IS REQUIRED FOR THE POLES. THIS DETAIL IS PROVIDED TO SHOW THE EXISTING BOLT PATTERN WHICH IS TO BE MET FOR THE CUSTOM BASE PLATE. THE CUSTOM BASE PLATE WILL VARY FROM THIS DETAIL AS REQUIRED FOR THE POLE.
2. IN LIEU OF DOOR OPENING SHOWN, A HINGED POLE IS REQUIRED. THE POLE IS TO HINGE 45° FROM MAIN AXIS. PROVIDE SPLIT ROUND COVER OVER THE CUSTOM BASE PLATE WITH FINISH TO MATCH POLE.
3. ALL POLE BASE DETAILS MUST BE CONFIRMED IN WRITING WITH THE OWNER PRIOR TO FABRICATION. AN ALTERNATE BOLT PATTERN MAY BE USED FOR SOME POLES AT OPTION OF OWNER.

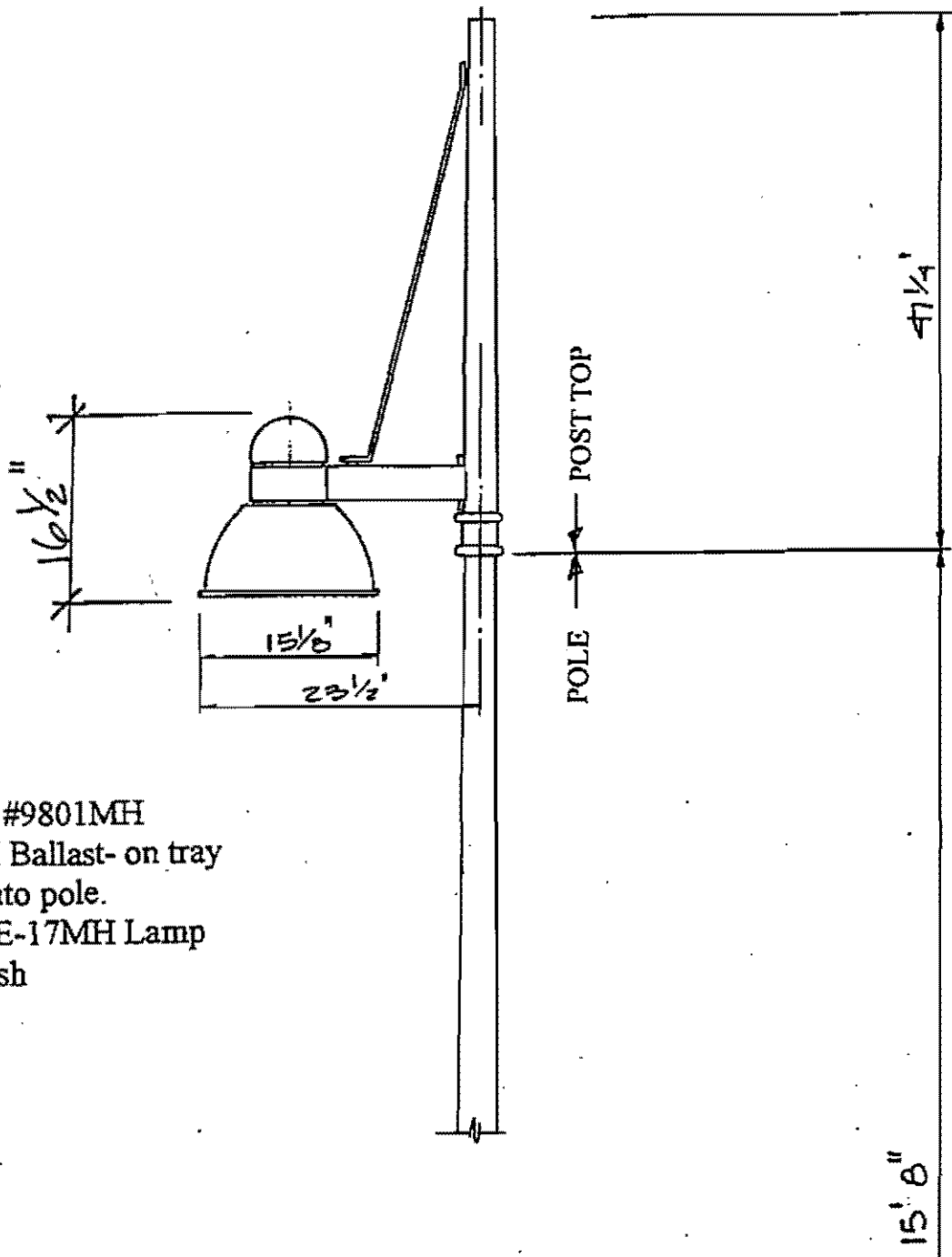

Notes:

1. Luminaire #9801MH
2. 175W MH Ballast- on tray recessed into pole.
3. (1) 175W E-17MH Lamp
4. Black Finish

POST TOP DETAIL

N.T.S.

BID FORM

**ADDISON CIRCLE PHASE I
STREET LIGHT POLE SYSTEMS
BID NO. 97-27**

Company Name: _____

Full Mailing

Address: _____
Number & Street/P.O. City State Zip

Phone Number: () _____ Fax: () _____

I have reviewed, read, and will abide by all pages of these specifications. I am a legal agent of the above named company and am fully authorized to sign this bid. Affiant further states that Bidder has not paid, given, or donated or agreed to pay, give or donate to any officer or employee of the Town of Addison any money or other thing of value, either directly or indirectly, in award of the bid.

Authorized Signature

Date

Print Name

Title

ACKNOWLEDGEMENT OF ADDENDA:

The Bidder acknowledges receipt of the following addenda, if addenda were issued and received:

Addendum No. 1 _____

Addendum No. 2 _____

Addendum No. 3 _____

**BID SCHEDULE
TRAFFIC SIGNAL POLE SYSTEMS
BID NO. 97-22**

Note: Prices must be shown in words and figures for each item listed in this proposal. In the event of discrepancy, the words shall control.

ITEM NO.	ESTIM. QTY.	UNIT	DESCRIPTION & UNIT PRICE IN WORDS	UNIT PRICE \$	AMOUNT BID \$
1	55		15'-8" light pole, anchor base and all accessories. Complete in Place, for the Sum of _____ _____ Dollars and Cents per unit.		
2	60		175 W metal halide lamps. Complete in Place, for the Sum of _____ _____ Dollars and Cents per unit.		
3	1		Delivery of Street Light Pole systems for Complete in Place, for the Sum of _____ _____ Dollars and Cents per unit.		

TOTAL AMOUNT BID FOR ITEMS 1 THROUGH 3 \$ _____

DELIVERY FROM DATE OF ORDER: _____ DAYS

REFERENCES:

<u>CUSTOMER</u> <u>NUMBER</u>	<u>CONTACT NAME</u>	<u>PHONE</u>
----------------------------------	---------------------	--------------

MANUFACTURER AND CATALOG NUMBERS OF PROPOSED POLES AND FIXTURES:



REED-STOWE & Co.
I N C O R P O R A T E D

RECEIVED
FEB 23 1996
CITY MANAGER

February 21, 1996

Mr. Ron Whitehead
Town Manager
Town of Addison
5300 Belt Line Road
Addison, TX 75240

*4-4-96
John
lets visit
of R*

Dear Ron:

Thank you once again for meeting with me yesterday. After I returned to my office, I performed some follow-up research on the streetlighting acquisition feasibility studies my firm has conducted over the past decade. We have conducted these studies for such cities as Arlington, Mesquite, Beaumont, Lewisville, Pampa, Clearwater, FL, and Indianapolis, In. All of the studies showed that the cities could substantially reduce expenses by acquiring the streetlighting system, and in the late 1980s Arlington did successfully complete an acquisition. However, Texas Utilities adopted a new policy of refusing to sell their streetlighting systems to any other city. Subsequently these cities who had completed feasibility studies were unable to obtain control of their systems.

In light of this information, before spending approximately \$19,000 to have us conduct an economic feasibility study on acquiring your streetlighting system, I would recommend the following options:

- 1) Request a meeting with your TU District Manager to determine whether the Company would entertain the prospect of selling it's streetlighting system. With the rapidly-changing electric market it is possible that they will have revised their no-sell policy. Jack Stowe and I would gladly assist you in preparing for and conducting such a meeting.
- 2) If TU remains unwilling to sell their system, engage either your city attorney or an outside counsel to investigate the legal options the City may have to compel the Company to sell its system. These legal options may include amendment of the City's franchise, refusal to renew an expiring franchise, etc. Condemnation may be another alternative but I believe such cities as Lewisville and Mesquite have explored this option with little success.

1651 N. COLLINS BLVD., SUITE 115
RICHARDSON, TEXAS 75080-3630
[214] 680-1880
FAX [214] 680-1999

101 W. SIXTH STREET, SUITE 225
AUSTIN, TEXAS 78701-2932
(512) 479-0991
FAX [512] 479-8992

- 3) If no legal, financial or other means can be used to persuade the Company to sell their streetlighting system, we could provide the Town with a study to evaluate other options to minimize its expenses and improve maintenance. These options would include but not be limited to:
- the Town retaining ownership of all newly installed streetlights, particularly in the new Addison Circle development;
 - the Town financing the replacement of mercury vapor bulbs with more efficient high pressure sodium vapor bulbs
 - the Town filing a complaint with the Company and/or the Public Utility Commission over deficiencies in the Company's streetlight maintenance program.

Ron, I remain willing to provide my firm's services to the Town but I feel that it would be a disservice to prepare an economic study of a streetlighting acquisition if that acquisition is not feasible for other reasons. Please call me after you have had a chance to review this letter so that we may discuss the Town's options in more detail.

Very Truly Yours,



Dan V. Jackson
Manager

Copy to Ron W 2-8-95
2-12-96



STREET DEPARTMENT

Post Office Box 144, Addison, Texas 75001

(214) 450-2841 FAX (214) 931-6643

16801 Westgrove

M E M O R A N D U M

To: John Baumgartner
From: Robin Jones *RJ*
Date: January 24, 1995
Subject: Monthly Street Lighting Costs

I have spent considerable time talking with our TU Electric representative and analyzing our current monthly charges. In order to understand the rates charged and service provided it's first necessary to understand something about our street lighting systems.

TU Electric bills us for 763 street lights every month. These are nonmetered lights and they cost the Town approximately \$9,800 each month. TU Electric charges for each lamp on a pole. Since many of our poles are in roadway medians, and have two lamps, the 763 streets lights are on 466 poles.

We also have five types of lights in Town. These consist of 175 watt and 400 watt mercury vapor lamps, 189 watt incandescent lamps, and 100 and 250 sodium vapor lamps.

TU Electric has four basic rate schedules. They are schedules A, B, C; and D. The cost of each lamp comes under one of these schedules. All Town of Addison lamps come under either schedule A or B. The rates associated with schedule A and B include all service to the facility, i.e. the replacement of burned out lamps, maintenance to the poles, underground wires, etc. Essentially, total service. Under schedule C, TU Electric would only replace burned out bulbs. Under schedule D, TU Electric would only supply power to the lights.

If we wanted to assume responsibility for some or all of the maintenance to our existing street lights we would obviously realize a reduction in our current rate.

It was a challenge trying to compute what our monthly rate would be if we were to choose to be under either schedule C or D. This in part because there is a fuel charge factored into the rate we're paying. This charge fluctuates from one type of lamp to another and can change every few months. The following numbers are purely estimates, but they shouldn't be too far off.

14,000 (1996)

We're currently paying almost \$10,000 per month for street lighting. If we were to choose to have TU Electric do no more than supply power and change burned out bulbs we could probably reduce our bill to about \$4,500 a month. If we bought electricity only, no other service, we would probably be paying about \$3,000 a month.

4,000 (1996)

Because our only real problem with TU Electric has been the amount of time it takes them to make repairs, I would suspect that if we did anything, we would choose schedule D. Schedule D being power only, no maintenance. Therefore, the next question would be, could we maintain our street lights for the remaining \$7,000 per month?

It's difficult to estimate what it would cost to maintain this system but some things to take into consideration would be:

1. Street light poles on Belt Line Road and Midway Road are 39 feet tall. These are higher than the reach of our current bucket truck. We would have to purchase a larger truck, estimated to cost about \$70,000. Since Mitch uses his truck full time right now, I suspect we will need both trucks, not one to replace the other.

2. We would need one employee to change bulbs and do minor repairs even if we decided to contract out all knock downs and cable replacement jobs. This person would have to be a licensed electrician, (\$40,000 a year plus benefits). It's possible this person could help Mitch on occasion and vice versa, but from time to time will probably also need assistance from the Street Department labor force.

3. To replace a pole on Belt Line or Midway Roads can cost up to \$4,000. All other street median poles would probably cost between \$1,500 and \$2,000. We could loose anywhere from 4 and 8 poles on Belt Line and Midway Roads per year and 4 to 8 poles on all other median streets per year. We would probably stock replacement poles, fixtures, cable, etc. and hire a contractor to pour the foundations, erect the poles, and install the fixtures.

4. All underground power cables would also become ours to repair and replace when necessary. This work would also have to be contracted out.

I'm sure there are other things I haven't considered but these should give you some things to think about. It may be possible to save some money each month, but I'm not convinced we will save anything in the long run. If there's any interest in looking closer at this issue, I would suggest our first step should be to have TU Electric give us their estimate of savings to us if they stopped doing all maintenance on our street lights. We can then start checking on prices for contractors to make typical repairs such as knock downs and cable replacements.

M E M O R A N D U M

To: John Baumgartner
From: Robin Jones *RJ*
Date: January 27, 1995
Subject: Supplemental Information to January 24, 1995 Memo
about Monthly Street Lighting Costs

I learned some interesting things during all my discussions with Quincy Bray about the service provided and rates charged to the Town by TU Electric.

When I first started quizzing Quincy about rates and such he was curious about what I was up to. I told him we were interested in what it would cost if we maintained our own street lights. Since I'm always after him about the length of time it takes them to repair a light, he said he felt it was a great idea if we maintained our own system. This was his general attitude over a period of a couple of weeks. The other day he told me he had mentioned what we were looking at to his superiors, and he was informed rather strongly that "TU Electric was in the street lighting Business". I don't know what they can do, but they may resist any attempt on our part to reduce the service they provide.

Also, I've had many conversations with Quincy about our bill and the various rate schedules he provided me for review. I discovered what I considered an error in their billing of our account. It has to do with the fact that we pay different rates for lamps on the same pole. It's too long to go into in this memo, but I argued we were being overcharged (I love to do that). As Quincy and I worked through this problem, we both came to the conclusion that the Town is probably being under billed. I didn't admit to anything, but I think he's right. However, I so wore Quincy out that he just wanted to drop the whole discussion. He did add though that if our account was ever audited, it would come out. I told him I still wasn't totally convinced we were being under billed but I didn't have time to fool with it right now myself. We left it at that.

The reason I mention this is, if Quincy is right, we're being under billed about \$1,700 per month. If we pursue investigating taking over our own street lighting operation we will generate an analysis of our account by Tu Electric. If we then don't actually go through with it, we may end up costing ourselves that extra \$1,700 per month.

Something to think about.

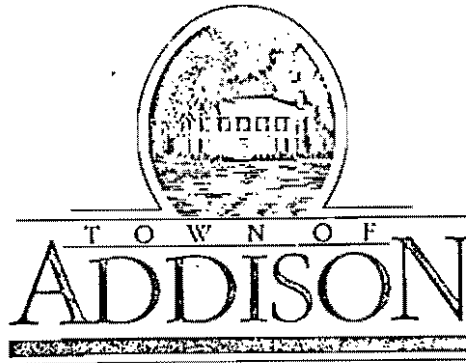

April 5, 1983

TO: Ron Whitehead
FROM: Robin Jones
SUBJECT: Possible Budget Adjustments

The following two accounts need to be considered for possible budget adjustments:

1. Equipment Maintenance: 01-05-0511, Traffic Signal System
2. Contractual Services: 01-05-0611, Utilities

In March there was a traffic controller equipment failure at the intersection of Midway Road and Lindberg. It was necessary to purchase and install a new controller and cabinet, totaling \$17,124.00. The traffic signal account has a budgeted amount of \$10,000, of which \$3,000 has been expended as of 4/3/83.

Due to a clerical error by Texas Power & Light in adding the Belt Line Road and Midway Road street lights to their computer, we were charged a customer-owned rate on these lights. This rate only covers electricity used. We should have been and are now (January, 1983) being charged a different rate which includes maintenance on these lights.

When this error was discovered and corrected by Texas Power & Light, it had a twofold effect on the Street Department Budget:

1. They are requesting that we make retroactive payment from January, 1982 to January, 1983, during which time they mis-billed this account approximately \$15,000.
2. The corrected billing has increased the Street Department monthly expenditure in this area from a budgeted \$2,500 per month to approximately \$5,700 per month.

Considering the above information, I project my expenditures for street lighting for the remainder of fiscal '82/'83 to be as follows:

March, \$5,700
April, \$5,700
May, \$6,500 (Midway Road north of Belt Line)
June, \$6,500



REED-STOWE & Co.
INCORPORATED

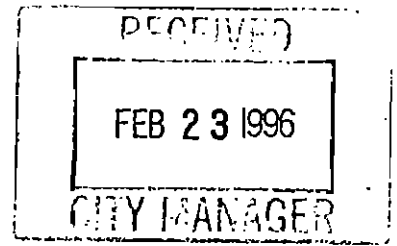

February 21, 1996

Mr. Ron Whitehead
Town Manager
Town of Addison
5300 Belt Line Road
Addison, TX 75240

*4-4-96
John
lets visit
of R =*

Dear Ron:

Thank you once again for meeting with me yesterday. After I returned to my office, I performed some follow-up research on the streetlighting acquisition feasibility studies my firm has conducted over the past decade. We have conducted these studies for such cities as Arlington, Mesquite, Beaumont, Lewisville, Pampa, Clearwater, Fl, and Indianapolis, In. All of the studies showed that the cities could substantially reduce expenses by acquiring the streetlighting system, and in the late 1980s Arlington did successfully complete an acquisition. However, Texas Utilities adopted a new policy of refusing to sell their streetlighting systems to any other city. Subsequently these cities who had completed feasibility studies were unable to obtain control of their systems.

In light of this information, before spending approximately \$19,000 to have us conduct an economic feasibility study on acquiring your streetlighting system, I would recommend the following options:

- 1) Request a meeting with your TU District Manager to determine whether the Company would entertain the prospect of selling it's streetlighting system. With the rapidly-changing electric market it is possible that they will have revised their no-sell policy. Jack Stowe and I would gladly assist you in preparing for and conducting such a meeting.
- 2) If TU remains unwilling to sell their system, engage either your city attorney or an outside counsel to investigate the legal options the City may have to compel the Company to sell its system. These legal options may include amendment of the City's franchise, refusal to renew an expiring franchise, etc. Condemnation may be another alternative but I believe such cities as Lewisville and Mesquite have explored this option with little success.

- 3) If no legal, financial or other means can be used to persuade the Company to sell their streetlighting system, we could provide the Town with a study to evaluate other options to minimize its expenses and improve maintenance. These options would include but not be limited to:
- the Town retaining ownership of all newly installed streetlights, particularly in the new Addison Circle development;
 - the Town financing the replacement of mercury vapor bulbs with more efficient high pressure sodium vapor bulbs
 - the Town filing a complaint with the Company and/or the Public Utility Commission over deficiencies in the Company's streetlight maintenance program.

Ron, I remain willing to provide my firm's services to the Town but I feel that it would be a disservice to prepare an economic study of a streetlighting acquisition if that acquisition is not feasible for other reasons. Please call me after you have had a chance to review this letter so that we may discuss the Town's options in more detail.

Very Truly Yours,



Dan V. Jackson
Manager