

TOWN OF ADDISON  
P. O. BOX 9010  
ADDISON, TX 75001-9010

P018854

10/14/04

09821 10/14/04 W-9 R019782

SBC SOUTHWESTERN BELL  
4801 MATLOCK RD, ROOM B-16  
ARLINGTON, TX 76018

TOWN OF ADDISON SERVICE CENTER  
16801 WESTGROVE  
ADDISON, TX 75001-5190

FAX:817-467-8198

JIM PIERCE

972-450-2879

1	1 EACH SBC RELOCATION DUE TO ARAPAHO RD.	36741.1100	36741.11
	EXT. PROJECT - CENTURION WAY		
	ACCOUNT DISTRIBUTION:		
	47-000-58210-83300	36741.11	

CONSENT AGENDA

#2C For

36741.11

w/SBC

10/12/2004

75-1333-555	SUB-TOTAL	36741.11
	TAX	0.00
	SHIPPING AND HANDLING CHARGE	0.00
AREA : UTILITIES SUE ELLEN FAIRLEY		36741.11



47 000 58210 83300

43-0529710

#09821

CWOTS #5166T04  
4801 Matlock Road, Room B16  
Arlington, Texas 76018

September 29, 2004

TOWN OF ADDISON  
P O Box 9010  
Addison, TX 75001

Dear Ms. Nicewander,

This letter is in regards to your request for Southwestern Bell Telephone, L.P. to perform custom work for you. Enclosed please find an Application and Letter of Agency for Custom Work. This application describes the custom work you have requested along with the associated charges for us to do the work. We require an advance payment on this amount, which is also shown on the application.

Both the signed application and the advance payment must be received by our office before we can proceed on your behalf with the work. Our mailing address for these documents is listed below:

Southwestern Bell Telephone, L.P.  
Attn: Shirley Meadows  
4801 Matlock Road, Room B16  
Arlington, Texas 76018

Fax number: 817 467-8198 or 1 800 851-7311

If you decide not to proceed with this work, please call our business office so that we may cancel your request. As always, please feel free to contact our office at 817 467-8124 or 1 888 321-8535 if you have any questions regarding this matter. Please refer to the record number at the top of your application to assist us in locating your file.

Sincerely,

*Shirley Meadows*

Shirley Meadows  
Southwestern Bell Telephone, L.P.



# Requisition

Next Screen

Req Header <sup>1</sup>	Req Detail	Item Descriptions <sup>3</sup>	Remarks <sup>4</sup>	Approval <sup>5</sup>	Req Summary <sup>6</sup>	Inquiries <sup>7</sup>	New Req
-------------------------	------------	--------------------------------	----------------------	-----------------------	--------------------------	------------------------	---------

Req #  Status  Change Auth

A/C/D	Type	Quantity	Unit Price	UOM	Dist Cd	Stock #	Whse	Budget Auth
Description				S/L	Account #		Catalog	B/O
<input type="checkbox"/>	<input type="checkbox"/>	<input type="text" value="1"/>	<input type="text" value="36741.11000"/>	<input type="text" value="EACH"/>	<input type="text"/>	<input type="text"/>	<input type="text"/>	<input type="text"/>
SBC RELOCATION DUE TO ARAPAHO RD. EXT. PROJECT - CENTURION WAY				<input type="text" value="S"/>	<input type="text" value="47-000-58210-83300"/>		<input type="text"/>	<input type="text"/>
				Item Desc S/L/E	<input type="text"/>	Deliver To	<input type="text"/>	

Defaults:

Vendor #/Name/Addr #  SOUTHWESTERN BELL  0

Commodity  /  /  /  Comm Desc  Enc

BPO #  BPO Ref #  FOB  Ship Date  Ship Via

Ship to  Bill to

Buyer  Hazard

Tax Code  Terms

Grant  Project  Task  WO #

Requester  Consolidate Asset Records  Work Code

PO #  Trans #  Total Encumbrance  0+ Bid

Line #  Detail Lines  Detail Total  0+ Bid #



# HP LaserJet 3200se



HP LASERJET 3200

OCT-18-2004 8:54AM

## Fax Call Report

Job	Date	Time	Type	Identification	Duration	Pages	Result
463	10/18/2004	8:52:09AM	Send	918008517311	1:59	5	OK

10/14/2004 07:55 FAX 817 4878198

SWBT

0001/008



FAX

Southwestern Bell  
4801 Mallock Rd, Room B-16  
Arlington, TX 76018  
817-467-8124 or 888-321-8535 Phone  
817-467-8198 or 800-851-7311 Fax

Date: ~~September 29, 2004~~ <sup>October 11, 2004</sup>

Attention: JENNY NICEWANDER

To From: Shirley Meadows

Comments: (FAX # 972 450-2837)

Here is the application and information regarding your custom work. Please be advised that I will need the original signed application and advance payment check as approval in our office before any work can proceed.

This estimate is good for 60 days. If after that time we do not have your approval to proceed, charges are no longer valid and the order will be canceled.

Please give me a call if you have questions regarding this estimate.

Number of pages: <sup>KS</sup> 5 (including this page)

If all pages are not received, please call: 817-467-8124 or 888-321-8535

This facsimile contains information which (a) may be LEGALLY PRIVILEGED, PROPRIETARY IN NATURE, OR OTHERWISE PROTECTED BY LAW FROM DISCLOSURE, and (b) is intended only for the use of the Addressee(s) named above. If you are not the Addressee, or the person responsible for delivering this to the Addressee(s), you are hereby notified that reading, copying or distributing this facsimile is prohibited. If you have received this facsimile in error, please telephone us immediately and mail the facsimile back to us at the above address. Thank you.

TOWN OF ADDISON  
P. O. BOX 9010  
ADDISON, TX 75001-9010

P018854

10/14/04

09821 10/14/04 W-9 R019782

SBC SOUTHWESTERN BELL  
4801 MATLOCK RD, ROOM B-16  
ARLINGTON, TX 76018

TOWN OF ADDISON SERVICE CENTER  
16801 WESTGROVE  
ADDISON, TX 75001-5190

FAX:817-467-8198

JIM PIERCE

972-450-2879

1	1 EACH SBC RELOCATION DUE TO ARAPAHO RD.	36741.1100	36741.11
	EXT. PROJECT - CENTURION WAY		
	ACCOUNT DISTRIBUTION:		
	47-000-58210-83300	36741.11	

75-1333-555

SUB-TOTAL 36741.11

TAX 0.00

SHIPPING AND HANDLING CHARGE 0.00

AREA : UTILITIES SUE ELLEN FAIRLEY

36741.11

TOWN OF  
ADDISON

PUBLIC WORKS

To: Shirley Meadows

From: Jenny Newland

Company: \_\_\_\_\_

FAX #: 817 467 8198

Date: 10-14-04

No. of pages (including cover): 2

Phone: 972/450-

Fax: 972/450-2837

16801 Westgrove

P.O. Box 9010

Addison, TX 75001-9010

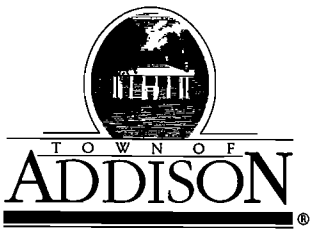

**Public Works / Engineering**

16801 Westgrove • P.O. Box 9010

Addison, Texas 75001

Telephone: (972) 450-2871 • Fax: (972) 450-2837

LETTER OF TRANSMITTAL

DATE	10/27/04	JOB NO.
ATTENTION		
RE:	MEAPAS PHAS 3	
	SBC CONTRACT	

TO Greg VanBuren

**GENTLEMAN:**

**WE ARE SENDING YOU**

- |   |  |
|---|--|
| <input type="checkbox"/> Attached       | <input type="checkbox"/> Under separate cover via _____ the following items: |
| <input type="checkbox"/> Shop Drawings  | <input type="checkbox"/> Plans   |
| <input type="checkbox"/> Copy of letter | <input type="checkbox"/> Samples   |
| <input type="checkbox"/> Change order   | <input type="checkbox"/> Specifications                                      |
|   | <input checked="" type="checkbox"/> <u>COPY OF CONTRACT</u>                  |

COPIES	DATE	NO.	DESCRIPTION
1			SBC CONTRACT

**THESE ARE TRANSMITTED as checked below:**

- |  |   |   |
|--|---|---|
| <input type="checkbox"/> For approval              | <input type="checkbox"/> Approved as submitted    | <input type="checkbox"/> Resubmit _____ copies for approval   |
| <input checked="" type="checkbox"/> For your use   | <input type="checkbox"/> Approved as noted        | <input type="checkbox"/> Submit _____ copies for distribution |
| <input type="checkbox"/> As requested              | <input type="checkbox"/> Returned for corrections | <input type="checkbox"/> Return _____ corrected prints        |
| <input type="checkbox"/> For review and comment    | <input type="checkbox"/> _____                    |   |
| <input type="checkbox"/> FOR BIDS DUE _____ 19____ |   | <input type="checkbox"/> PRINTS RETURNED AFTER LOAN TO US     |

REMARKS \_\_\_\_\_

\_\_\_\_\_

\_\_\_\_\_

\_\_\_\_\_

\_\_\_\_\_

COPY TO file

SIGNED: [Signature]

If enclosures are not as noted, please notify us at once.

> My email address will change tomorrow to:  
> annette\_morris2@cable.comcast.com  
>  
> I am sorry for any inconvenience that this causes. Unfortunately, I am  
> having a problem with spam.  
>  
> Also, I will be on vacation next week from October 11 through October 15.  
> Please send pole transfer requests to me, but also send to: C.J.  
> Brands at: chris\_brands@cable.comcast.com  
> Warren Fyffe at:  
> warren\_fyffe@cable.comcast.com  
>  
>  
> C.J. Brands handles the East Area consisting of the following communities:  
> Garland, Anderson, College, Commerce, Cooper, Elkhart, Graham, Greenville,  
> Mesquite, Palestine, Point Royal, Rowlett, Sachse, Southfork, St. Paul,  
> Sunnyvale, Wylie, Dallas, Cedar Hill, Cockrell Hill, Desoto, Hutchins, and  
> Lancaster.  
>  
> Warren Fyffe handles the West Area consisting of the following  
> communities: Farmers Branch, Addison, Carrollton, Coppell, Double Oak,  
> Flower Mound, Grapevine, Hebron, Highland Village, Irving, Lewisville, Los  
> Colinas, The colony, Valley Ranch, Arlington, Bedford, Colleyville,  
> Dalworthington Gardens, Euless, Grand Prairie, Pantego, Plano, Allen,  
> Farmersville, Frisco, McKinney, Murphy, Parker, Princeton, Richardson, and  
> Stonebridge Ranch.  
>  
> Should you have any issues with pole transfers while I am on vacation, you  
> may call C.J. or Warren at 817-557-8296. Their fax number is  
> 817-419-6702. Should you have any questions, please contact me at  
> 214-320-7415.

> Thanks,

> Annette Morris  
> Comcast Cable Communications, Inc.  
> Construction Liaison/Contract Administrator  
> 1565 Chenault St.  
> Dallas, TX 75228-5456  
> Office Phone - 214-320-7415  
> Fax Number - 214-320-7559  
> Email - annette\_morris2@cable.comcast.com  
>

← COMCAST  
CONTACT



---

**CONSENT AGENDA**

---

#2a – Approval of the Minutes for the September 28, 2004 Council Meeting.

---

#2b – Consideration of approval of final payment in the amount of \$14,526.74 to Ratliff Hardscape, LTD. for the replacement of masonry walls on Chancey Drive and Proton Drive in the Les Lacs residential area.

---

#2c – Consideration of a Resolution authorizing the City Manager to enter into a contract in the amount of \$36,741.11 with SBC for the relocation and installation of telephone cable in connection with the extension of Arapaho Road, Phase III, from Addison Road to Surveyor Boulevard.

---

*Approved*

#2d – Consideration of a Resolution authorizing the City Manager to enter into an agreement with Hand and Associates Marketing Communications for advertisement in the November 2004, March 2005 and August 2005 Addison/North Dallas Corridor Guide publication.

---

#2e – Consideration of a Resolution authorizing the City Manager to enter into a contract in the amount of \$49,896.00 with Hotel Inter-Continental for meeting space and room guarantees for the 2005 North Texas Jazz Festival.

---

#2f – Consideration of a Resolution authorizing the City Manager to enter into an agreement in an amount not to exceed \$30,000 with the City of Carrollton for service and maintenance provided for the Police and Fire Radio System in Fiscal Year 2003-2004.

---



CWOTS #5166T04  
4801 Matlock Road, Room B16  
Arlington, Texas 76018

September 29, 2004

TOWN OF ADDISON  
P O Box 9010  
Addison, TX 75001

Dear Ms. Nicewander,

This letter is in regards to your request for Southwestern Bell Telephone, L.P. to perform custom work for you. Enclosed please find an Application and Letter of Agency for Custom Work. This application describes the custom work you have requested along with the associated charges for us to do the work. We require an advance payment on this amount, which is also shown on the application.

Both the signed application and the advance payment must be received by our office before we can proceed on your behalf with the work. Our mailing address for these documents is listed below:

Southwestern Bell Telephone, L.P.  
Attn: Shirley Meadows  
4801 Matlock Road, Room B16  
Arlington, Texas 76018

Fax number: 817 467-8198 or 1 800 851-7311

If you decide not to proceed with this work, please call our business office so that we may cancel your request. As always, please feel free to contact our office at 817 467-8124 or 1 888 321-8535 if you have any questions regarding this matter. Please refer to the record number at the top of your application to assist us in locating your file.

Sincerely,

*Shirley Meadows*

Shirley Meadows  
Southwestern Bell Telephone, L.P.

8056 Contract Cost



**FAX**

Southwestern Bell  
4801 Matlock Rd, Room B-16  
Arlington, TX 76018  
817-467-8124 or 888-321-8535 Phone  
817-467-8198 or 800-851-7311 Fax

---

**Date: September 29, 2004**

.....  
**Attention: JENNY NICEWANDER**

.....  
**From: Shirley Meadows**

.....  
**Comments: (FAX # 972 450-2837)**

Here is the application and information regarding your custom work. Please be advised that I will need the **original signed application and advance payment check as approval** in our office before any work can proceed.

This estimate is good for 60 days. If after that time we do not have your approval to proceed, charges are no longer valid and the order will be canceled.

Please give me a call if you have questions regarding this estimate.

Number of pages: <sup>6</sup>5 (including this page)

---

If all pages are not received, please call: 817-467-8124 or 888-321-8535

This facsimile contains information which (a) may be LEGALLY PRIVILEGED, PROPRIETARY IN NATURE, OR OTHERWISE PROTECTED BY LAW FROM DISCLOSURE, and (b) is intended only for the use of the Addressee(s) named above. If you are not the Addressee, or the person responsible for delivering this to the Addressee(s), you are hereby notified that reading, copying or distributing this facsimile is prohibited. If you have received this facsimile in error, please telephone us immediately and mail the facsimile back to us at the above address. Thank you.

CWOTS #5166T04  
4801 Matlock Road, Room B-16  
Arlington, TX 76018



## APPLICATION and LETTER OF AGENCY FOR CUSTOM WORK

September 29, 2004

CWOTS Number: 5166T04  
Customer Billing Telephone Number: 972 450-7000

BILL TO: TOWN OF ADDISON  
P O Box 9010  
Addison, TX 75001

ORIGINAL  
SENT TO GAYE

LOCATION OF WORK: Rear of 4101 Centurion Way to the rear of 4139 Centurion Way, Addison TX

DESCRIPTION OF CUSTOM WORK: This estimated cost is issued to place cable, hand hole, and five pedestals from the rear of 4101 Centurion Way to the rear of 4139 Centurion Way, Addison, TX. This relocation is needed due to the Arapaho Road Extension Project by the Town of Addison. These charges only reflect the scope of work on this project at this location. SBC will need 905' of 600 pair cable, 100' of 200 pair cable, 90' of 100 pair cable, and one new hand hole. SBC will backhoe trench cable in dirt with 30" of cover, machine dig 3 splice pits and place 5 pedestals in conjunction with other work. SBC will remove 2 hand holes and place a new hand hole over the existing structure. Hand hole will be 4'X8'X6'.

LABOR EXPENSE: \$25,018.51; MATERIAL EXPENSE: \$5,286.95; OVERHEAD EXPENSE: \$5,846.33;  
COST OF MONEY EXPENSE: \$589.32 (w/purchase order)

CHARGE FOR CUSTOM WORK: ESTIMATED COST: \$ 36,151.79 (Advance Payment)  
\$ 36,741.11 (W/Purchase Order)  
(Actual charges may exceed this estimated cost.)

Applicant requests that Southwestern Bell Telephone, L.P. act as its agent in performing the above-described custom work on Applicant's behalf. Applicant agrees to pay the charge(s) indicated above for such work. The work is to be done on an "Actual Cost" basis, all charge(s) will be computed in accordance with Southwestern Bell Corporation's ordinary accounting practices under the Uniform System of Accounts for Class A telephone companies and will include allocated costs for labor, engineering, materials, transportation, motor vehicles, tool and supply expenses and sundry billings from sub-contractors and suppliers for work and materials related to the job. The Applicant affirms that the cost estimate furnished by the Telephone Company has been considered only as an estimate of approximate costs and that the actual costs incurred by the Telephone Company in doing the work at the particular time and location might be higher. Said estimated cost is subject to change due to any number of factors including, but not limited to, changing conditions in the field, weather delays, or changes in the scope of the work.

### CHANGE ORDERS

Should concealed conditions exist, including conditions that may exist below the surface of the ground, or if conditions exist that could not have been anticipated by Southwestern Bell Telephone, L.P. at the time of this agreement, Southwestern Bell Telephone, L.P. will be entitled to additional funds and/or additional time to complete the work. Southwestern Bell Telephone, L.P. will request such additional funding and/or additional time through a request for a change order.

Should Applicant or its agents, servants, or employees order or seek changes in the scope of the work, Southwestern Bell Telephone, L.P. is entitled to seek from Applicant, its agents, servants, or employees, additional

funds as necessary to perform the work, and additional time, as necessary to complete the work. Said request for additional funds and/or additional time will be through change order.

All change orders will be in writing.

All change orders will be submitted and accepted by Applicant, its agents, servants or employees, before Southwestern Bell Telephone, L.P. proceeds to execute the work or, if work has been initiated on the project, continues with executing the work except in an emergency endangering life or property.

Applicant, its agents, servants or employees, are deemed to have accepted the terms of any change order by signing where indicated on the change order.

Under no circumstances will Southwestern Bell Telephone, L.P.'s request for a change order be deemed or used as evidence of delay on the project. Nor will any change order issued in this project be used to charge Southwestern Bell Telephone, L.P. with responsibility for any alleged delay on the project.

#### NO DAMAGE FOR DELAY

Under no circumstances will Southwestern Bell Telephone, L.P. be held liable to Applicant, Applicant's agents, employees, or contractors, for any alleged delay on the project that forms the basis for this custom work order.

#### TIME TO COMPLETE

Any representation by Southwestern Bell Telephone, L.P., its agents, servants or employees that the project, or any additional work authorized by change order, will be complete by a certain date or certain time period is strictly an estimate and not binding on Southwestern Bell Telephone, L.P., its agents, servants, or employees. All estimated completion dates are subject to changing conditions in the field, changes in the scope of the work, relocation of existing utilities not within Southwestern Bell Telephone, L.P.'s control, Acts of God, weather delays, labor disputes, vendor/contractor disputes, and other conditions or circumstances that Southwestern Bell Telephone, L.P., its agents, servants, or employees, could not reasonably anticipate at the time of the estimate.

#### PAYMENT

Applicant agrees to make an advance payment of **\$ 36,151.79** prior to commencement of the work. Applicable charges for Custom Work will be billed on a special bill separate from the bill that Applicant receives for telephone service.

Applicant, its agents, servants, or employees agree to make payment on change orders within thirty (30) days of the date of signature on the change order. Failure to make payment within the designated thirty (30) day time period will operate to cancel the change order and Southwestern Bell Telephone, L.P. will cease all work activity on the project until payment is made.

When the Applicant agrees to Interval Billing \*, the balance of the Contract Price or Actual Cost (as applicable) will be made in monthly payments. If the Actual Cost made varies from the Estimated Cost, then a correcting adjustment will be made in the last payment. If the parties cannot agree to Interval Billing, Applicant will make an advance payment as indicated above.

\*Applicable to orders over \$25,000 and work will take 6 or more months to complete.

#### CANCELLATION

If the applicant cancels the work prior to completion, Applicant agrees to pay Southwestern Bell Telephone, L.P. for the costs it has incurred in starting performance under the contract and before being notified to cease only.

If Applicant elects to cancel the work prior to completion, Applicant agrees to pay Southwestern Bell Telephone, L.P. for the costs it has incurred in starting performance under the contract. If Applicant has made an advance payment, Southwestern Bell Telephone, L.P. will deduct its costs and expenses incurred as of the date of Applicant's notice of cancellation from the amount of the advance payment. Any amount remaining will be refunded to Applicant.

#### ESTIMATED PRICE QUOTE

The above estimated price is guaranteed for 60 days from September 29, 2004. If the charges are not accepted within 60 days the order will be cancelled and a new order will need to be placed. The second estimate may be higher than the estimated price set out above.

STOP WORK ORDER

In the event that Applicant issues a stop work order, or places the project "on hold", at any point during the progress of the work, said stop work order or request to "hold" work must be issued in writing and must be delivered via certified mail, return receipt requested to **Bill Mize, 11930 Airline, Rm. 215, Houston, TX 77037**. If Applicant issues a stop work order, or a request to "hold" work, the contract price quoted herein will remain valid until sixty (60) days from the date of the stop work or "hold" work order. At the expiration of the sixty (60) days, the contract price quoted herein will expire and a new contract price will be determined and provided, in writing, to Applicant. The new contract price may be higher than the contract price quoted in this custom work order. If, after issuing a stop work, or "hold" work order, Applicant elects to cancel the contract, Applicant must inform Southwestern Bell, L.P., in writing of the cancellation. Southwestern Bell Telephone, L.P. will deduct any expenses incurred in performing the work from Applicant's advance payment and refund any remaining funds to Applicant.

Under no circumstances will Southwestern Bell Telephone, L.P. be responsible to Applicant for any alleged damages or additional expenses incurred by Applicant as a result of a stop work order or an order to "hold" work on the project.

CHOICE OF LAW AND ARBITRATION

Should any dispute arise between the parties concerning the subject matter of this agreement, or any term contained therein, the parties agree that the dispute or claim shall be submitted to binding arbitration before the American Arbitration Association. The parties further agree that the prevailing party in any such dispute will be entitled to recover attorney's fees and costs of arbitration.

Texas law governs the application of this agreement and all terms contained therein.

INDEMNIFICATION AND HOLD HARMLESS

Applicant, its agents, servants, and employees hereby agree to indemnify and hold harmless ~~Southwestern Bell Telephone, L.P., and its employees, agents and contractors, from and against any and all claims, costs, expenses, judgments or actions for damage to property or injury or death to persons, and/or arising from or relating to the work that is the subject of this agreement, to the extent any such claims are caused by the negligent acts or omissions of the Applicant, its agents, servants, or employees.~~

ENTIRE AGREEMENT

The parties agree that the terms set forth herein constitute the entire agreement and there are no other agreements regarding the project that is the subject of this agreement between the parties.

MODIFICATION & NOTICE

Any modification to this agreement must be made in writing and signed by both parties.

Any party to this agreement may provide the other party with notice of any fact or condition by providing such information in writing and serving said writing via certified mail, return receipt requested.

ACCEPTED FOR CUSTOMER:



Authorized Signature, Title or Relationship to Company or Individual Company:

Company: TOWN OF ADDISON  
Printed Name: MICHAEL E. MURPHY

Date: 10/18/04  
DIRECTOR OF PUBLIC WORKS/  
ACTING CITY MANAGER

8056 Actual Cost

ACCEPTED FOR Southwestern Bell Telephone, L.P.:



Title: Mgr Oprs-Cntl/CWOTS

Date: September 29, 2004

## CUSTOM WORK ORDER #5166T04

## TOWN OF ADDISON

THIS COST ESTIMATE IS ISSUED TO PLACE CABLE, HAND HOLE, AND 5 PEDESTALS FROM THE REAR OF 5101 CENTURION WAY TO THE REAR OF 4139 CENTURION WAY, ADDISON TX.

## BREAKDOWN OF CHARGES:

BROAD GAUGE WORK SHEET  
RECORD 5166T04 JOB

MATERIAL DESCRIPTION	MATL/CONTR QTY	CAPITAL COST (EA)	EXPENSE C, *RUC M, *X	TOTAL
ANWM 600 PR CA	905	4.07	3683.35	0.00 3683.35
ANMW 200 PR CA	100	1.37	137.00	0.00 137.00
ANMW 100 PR CA	90	0.74	66.60	0.00 66.60
HANDHOLE	1	1400.00	1400.00	0.00 1400.00
TRENCH CABLE (C)	1	10145.00	10145.00	0.00 10145.00
ENGR (S)	32	113.43	3629.76	0.00 3629.76
TECH (S)	125	89.95	11243.75	0.00 11243.75

CONTRACTOR: LABOR 10145.00 SWBT: LABOR 14873.51 MATERIAL 5286.95

CONTRACTOR LABOR: \$10,145.00

SWBT LABOR: \$14,873.51

MATERIALS: \$ 5,286.95

MISC. ADMIN CHARGES: \$ 5,846.33

TOTAL: \$36,151.79

PURCHASE ORDER COST \$ 589.32

TOTAL WITH P.O. \$36,741.11

DATE SUBMITTED: October 1, 2004  
FOR COUNCIL MEETING: October 12, 2004

**Council Agenda Item #**

**SUMMARY:**

This item is for Council authorization for the City Manager to enter into a Contract Agreement with SBC for the relocation and installation of telephone cable in connection with the extension of Arapaho Road, Phase III, from Addison Road to Surveyor Blvd.

**FINANCIAL IMPACT:**

Budgeted Amount: Utility relocation is part of the \$22.8 million allocated for the Arapaho Road, Phase III

Cost: \$36,741.11

Source of Funds: Funds have been appropriated in fiscal year 2005 from the Street, 2002, 2004 Capital Project funds.

**BACKGROUND:**

Of the many aspects relating to the Arapaho Road, Phase III construction project, the relocation of all affected utilities is a substantial undertaking. SBC has recently determined that existing telephone cables along the project limits, must be relocated at this time. In accordance with the attached agreement, SBC will place cable, hand hole, and several pedestals behind each business on the north side of Centurion Way. Money had been allocated to accommodate funding requirements for this portion of the project and it is within the existing budget limits.

**RECOMMENDATION:**

Staff recommends that the City Manager be authorized to enter into an agreement with SBC, in the amount of \$36,741.11, for relocation and installation of telephone cable in connection with the extension of Arapaho Road, Phase III, from Addison Road to Surveyor Blvd.





funds as necessary to perform the work, and additional time, as necessary to complete the work. Said request for additional funds and/or additional time will be through change order.

All change orders will be in writing.

All change orders will be submitted and accepted by Applicant, its agents, servants or employees, before Southwestern Bell Telephone, L.P. proceeds to execute the work or, if work has been initiated on the project, continues with executing the work except in an emergency endangering life or property.

Applicant, its agents, servants or employees, are deemed to have accepted the terms of any change order by signing where indicated on the change order.

Under no circumstances will Southwestern Bell Telephone, L.P.'s request for a change order be deemed or used as evidence of delay on the project. Nor will any change order issued in this project be used to charge Southwestern Bell Telephone, L.P. with responsibility for any alleged delay on the project.

NO DAMAGE FOR DELAY

Under no circumstances will Southwestern Bell Telephone, L.P. be held liable to Applicant, Applicant's agents, employees, or contractors, for any alleged delay on the project that forms the basis for this custom work order.

TIME TO COMPLETE

Any representation by Southwestern Bell Telephone, L.P., its agents, servants or employees that the project, or any additional work authorized by change order, will be complete by a certain date or certain time period is strictly an estimate and not binding on Southwestern Bell Telephone, L.P., its agents, servants, or employees. All estimated completion dates are subject to changing conditions in the field, changes in the scope of the work, relocation of existing utilities not within Southwestern Bell Telephone, L.P.'s control, Acts of God, weather delays, labor disputes, vendor/contractor disputes, and other conditions or circumstances that Southwestern Bell Telephone, L.P., its agents, servants, or employees, could not reasonably anticipate at the time of the estimate.

PAYMENT

Applicant agrees to make an advance payment of **\$ 36,151.79** prior to commencement of the work. Applicable charges for Custom Work will be billed on a special bill separate from the bill that Applicant receives for telephone service.

Applicant, its agents, servants, or employees agree to make payment on change orders within thirty (30) days of the date of signature on the change order. Failure to make payment within the designated thirty (30) day time period will operate to cancel the change order and Southwestern Bell Telephone, L.P. will cease all work activity on the project until payment is made.

When the Applicant agrees to Interval Billing \*, the balance of the Contract Price or Actual Cost (as applicable) will be made in monthly payments. If the Actual Cost made varies from the Estimated Cost, then a correcting adjustment will be made in the last payment. If the parties cannot agree to Interval Billing, Applicant will make an advance payment as indicated above.

\*Applicable to orders over \$25,000 and work will take 6 or more months to complete.

CANCELLATION

If the applicant cancels the work prior to completion, Applicant agrees to pay Southwestern Bell Telephone, L.P. for the costs it has incurred in starting performance under the contract and before being notified to cease only.

If Applicant elects to cancel the work prior to completion, Applicant agrees to pay Southwestern Bell Telephone, L.P. for the costs it has incurred in starting performance under the contract. If Applicant has made an advance payment, Southwestern Bell Telephone, L.P. will deduct its costs and expenses incurred as of the date of Applicant's notice of cancellation from the amount of the advance payment. Any amount remaining will be refunded to Applicant.

ESTIMATED PRICE QUOTE

The above estimated price is guaranteed for 60 days from September 29, 2004. If the charges are not accepted within 60 days the order will be cancelled and a new order will need to be placed. The second estimate may be higher than the estimated price set out above.

**STOP WORK ORDER**

In the event that Applicant issues a stop work order, or places the project "on hold", at any point during the progress of the work, said stop work order or request to "hold" work must be issued in writing and must be delivered via certified mail, return receipt requested to **Bill Mize, 11930 Airline, Rm. 215, Houston, TX 77037**. If Applicant issues a stop work order, or a request to "hold" work, the contract price quoted herein will remain valid until sixty (60) days from the date of the stop work or "hold" work order. At the expiration of the sixty (60) days, the contract price quoted herein will expire and a new contract price will be determined and provided, in writing, to Applicant. The new contract price may be higher than the contract price quoted in this custom work order. If, after issuing a stop work, or "hold" work order, Applicant elects to cancel the contract, Applicant must inform Southwestern Bell, L.P., in writing of the cancellation. Southwestern Bell Telephone, L.P. will deduct any expenses incurred in performing the work from Applicant's advance payment and refund any remaining funds to Applicant.

Under no circumstances will Southwestern Bell Telephone, L.P. be responsible to Applicant for any alleged damages or additional expenses incurred by Applicant as a result of a stop work order or an order to "hold" work on the project.

**CHOICE OF LAW AND ARBITRATION**

Should any dispute arise between the parties concerning the subject matter of this agreement, or any term contained therein, the parties agree that the dispute or claim shall be submitted to binding arbitration before the American Arbitration Association. The parties further agree that the prevailing party in any such dispute will be entitled to recover attorney's fees and costs of arbitration.

Texas law governs the application of this agreement and all terms contained therein.

**INDEMNIFICATION AND HOLD HARMLESS**

**Applicant, its agents, servants, and employees hereby agree to indemnify and hold harmless Southwestern Bell Telephone, L.P., and its employees, agents and contractors, from and against any and all claims, costs, expenses, judgments or actions for damage to property or injury or death to persons, and/or arising from or relating to the work that is the subject of this agreement, to the extent any such claims are caused by the negligent acts or omissions of the Applicant, its agents, servants, or employees.**

**ENTIRE AGREEMENT**

The parties agree that the terms set forth herein constitute the entire agreement and there are no other agreements regarding the project that is the subject of this agreement between the parties.

**MODIFICATION & NOTICE**

Any modification to this agreement must be made in writing and signed by both parties.

Any party to this agreement may provide the other party with notice of any fact or condition by providing such information in writing and serving said writing via certified mail, return receipt requested.

**ACCEPTED FOR CUSTOMER:**

\_\_\_\_\_  
Authorized Signature, Title or  
Relationship to Company or Individual  
Company: \_\_\_\_\_  
Printed Name: \_\_\_\_\_  
Date: \_\_\_\_\_

**ACCEPTED FOR Southwestern Bell Telephone, L.P.:**

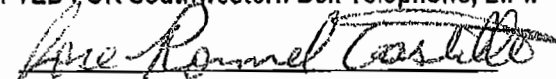
  
Title: Mgr Oprs-Cntl/CWOTS  
Date: September 29, 2004

## CUSTOM WORK ORDER #5166T04

## TOWN OF ADDISON

THIS COST ESTIMATE IS ISSUED TO PLACE CABLE, HAND HOLE, AND 5 PEDESTALS FROM THE REAR OF 5101 CENTURION WAY TO THE REAR OF 4139 CENTURION WAY, ADDISON TX.

## BREAKDOWN OF CHARGES:

BROAD GAUGE WORK SHEET  
RECORD 5166T04 JOB

MATERIAL DESCRIPTION	MATL/CONTR QTY	CAPITAL COST (EA)	EXPENSE C, *RUC M, *X	TOTAL
ANWM 600 PR CA	905	4.07	3683.35	0.00 3683.35
ANMW 200 PR CA	100	1.37	137.00	0.00 137.00
ANMW 100 PR CA	90	0.74	66.60	0.00 66.60
HANDHOLE	1	1400.00	1400.00	0.00 1400.00
TRENCH CABLE (C)	1	10145.00	10145.00	0.00 10145.00
ENGR (S)	32	113.43	3629.76	0.00 3629.76
TECH (S)	125	89.95	11243.75	0.00 11243.75

CONTRACTOR: LABOR 10145.00 SWBT: LABOR 14873.51 MATERIAL 5286.95

---

CONTRACTOR LABOR:	\$10,145.00
SWBT LABOR:	\$14,873.51
MATERIALS:	\$ 5,286.95
MISC. ADMIN CHARGES:	\$ 5,846.33
TOTAL:	\$36,151.79
PURCHASE ORDER COST	\$ 589.32
TOTAL WITH P.O.	\$36,741.11



**Facsimile Transmittal**

Date: 09/15/03

From: **Grantham & Associates, Inc.**

Fax To: JENNY NICEWANDER

1919 S. Shiloh Rd.

Suite 310, L.B. 8

Of: TOWN OF ADDISON

Garland, Texas 75042

Tel. (972) 864-2333

Fax# (972)450-2837

Fax (972) 864-2334

Email: Info@gra-ce.net

Ref: A123 - SBC

# of Pages (including this sheet): 5

Fax From: KATURA

**Comments:**

Jenny,

(Attached to this cover is) the SBC work order dated 12/31/2004. It is the "letter" that my previous e-mail referred to. Let me know if you have any questions. You might review any correspondence between you and Duke around March and April 2004 for information about the conduit on the west side of Midway.

KATURA

This message is intended only for the use of the individual or entity to which it is addressed, and may contain information that is privileged, confidential and exempt from disclosure under applicable law. If the reader of this message is not the intended recipient, or the employee or agent responsible for delivering the message to the intended recipient, you are hereby notified that any dissemination, distribution or copying of this communication is strictly prohibited. If you have received this communication in error, please notify us immediately by telephone, and return the original message to us at the above address via the U.S. Postal Service. Thank you.



CWOTS # 4185T03  
4801 Matlock Road, Room B16  
Arlington, Texas 76018

December 31, 2003

TOWN OF ADDISON  
P O Box 9010  
Addison, TX 75001

Dear Mr. Jalbert,

This letter is in regards to your request for Southwestern Bell Telephone, L.P. to perform custom work for you. Enclosed please find an Application and Letter of Agency for Custom Work. This application describes the custom work you have requested along with the associated charges for us to do the work. We require an advance payment on this amount, which is shown on the application.

Both the signed application and the advance payment must be received by our office before we can proceed on your behalf. Our mailing address for these documents is listed below:

Southwestern Bell Telephone, L.P.  
Attn: Shirley Meadows  
4801 Matlock Road, Room B16  
Arlington, Texas 76018

If you decide not to proceed with this work, please call our business office so that we may cancel your request. As always, please feel free to contact our business office at 1 800 303-7477 if you have any questions regarding this matter. Please refer to the record number at the top of your application to assist us in locating your file.

Sincerely,

*Shirley Meadows*

Shirley Meadows  
CWOTS Department  
Southwestern Bell Telephone, L.P.  
817 467-8124 or 1-888-321-8535 Phone  
817 467-8198 or 1-800-851-7311 Fax

*Bruner Baker*

*214-920-0190*

*SBC.*

8056 Actual Cost

CWOTS # 4185T03  
4801 Matlock Road, Room B16  
Arlington, Texas 76018



### APPLICATION and LETTER OF AGENCY FOR CUSTOM WORK

December 31, 2003

CWOTS Number: 4185T03

Customer Billing Telephone Number: 972 450-7000

**BILL TO:** TOWN OF ADDISON  
P O Box 9010  
Addison, TX 75001

**DESCRIPTION OF CUSTOM WORK:**

This cost estimate is for the extension of Arapaho Road from Surveyor Road to Addison Road. This job will reroute conduit run under new box culvert. Contract engineer will design job.

**CHARGE FOR CUSTOM WORK:** ESTIMATED COST: \$ 44,359.10+ tax  
(Actual charges may exceed this estimated cost.)  
\*\*\*IF USING A PURCHASE ORDER ESTIMATED COST WILL BE \$45,124.75\*\*\*  
**ESTIMATED LABOR: \$ 34,064.31; ESTIMATED MATERIALS: \$ 6,128.88;**  
**ESTIMATED OVERHEAD EXPENSE: \$ 4,165.91**

Applicant requests that Southwestern Bell Telephone, L.P. act as its agent in performing the above-described custom work on Applicant's behalf. Applicant agrees to pay the charge(s) indicated above for such work. The work is to be done on an "Actual Cost" basis, all charge(s) will be computed in accordance with Southwestern Bell Corporation's ordinary accounting practices under the Uniform System of Accounts for Class A telephone companies and will include allocated costs for labor, engineering, materials, transportation, motor vehicles, tool and supply expenses and sundry billings from sub-contractors and suppliers for work and materials related to the job. The Applicant affirms that the cost estimate furnished by the Telephone Company has been considered only as an estimate of approximate costs and that the actual costs incurred by the Telephone Company in doing the work at the particular time and location might be higher. Said estimated cost is subject to change due to any number of factors including, but not limited to, changing conditions in the field, weather delays, or changes in the scope of the work.

CHANGE ORDERS

Should concealed conditions exist, including conditions that may exist below the surface of the ground, or if conditions exist that could not have been anticipated by SBC at the time of this agreement, SBC will be entitled to additional funds and/or additional time to complete the work. SBC will request such additional funding and/or additional time through a request for a change order.

Should Applicant or its agents, servants, or employees order or seek changes in the scope of the work, SBC is entitled to seek from Applicant, its agents, servants, or employees, additional funds as necessary to perform the work, and additional time, as necessary to complete the work. Said request for additional funds and/or additional time will be through change order.

All change orders will be in writing.

All change orders will be submitted and accepted by Applicant, its agents, servants or employees, before SBC proceeds to execute the work or, if work has been initiated on the project, continues with executing the work except in an emergency endangering life or property.

Applicant, its agents, servants or employees, are deemed to have accepted the terms of any change order by signing where indicated on the change order.

8056 Actual Cost



Under no circumstances will SBC's request for a change order be deemed or used as evidence of delay on the project. Nor will any change order issued in this project be used to charge SBC with responsibility for any alleged delay on the project.

#### TIME TO COMPLETE

Any representation by SBC, its agents, servants or employees that the project, or any additional work authorized by change order, will be complete by a certain date or certain time period is strictly an estimate and not binding on SBC, its agents, servants, or employees. All estimated completion dates are subject to changing conditions in the field, changes in the scope of the work, relocation of existing utilities not within SBC's control, Acts of God, weather delays, labor disputes, vendor/contractor disputes, and other conditions or circumstances that SBC, its agents, servants, or employees, could not reasonably anticipate at the time of the estimate.

#### PAYMENT

Applicant agrees to make an advance payment of \$ 44,359.10 prior to commencement of the work and agrees to pay the applicable taxes when the work is completed. Applicable charges for Custom Work will be billed on a special bill separate from the bill that Applicant receives for telephone service.

Applicant, its agents, servants, or employees agree to make payment on change orders within thirty (30) days of the date of signature on the change order. Failure to make payment within the designated thirty (30) day time period will operate to cancel the change order and SBC will cease all work activity on the project until payment is made.

When the Applicant agrees to Interval Billing \*, the balance of the Contract Price or Actual Cost (as applicable) will be made in monthly payments. If the Actual Cost made varies from the Estimated Cost, then a correcting adjustment will be made in the last payment.

#### CANCELLATION

If the applicant cancels the work prior to completion, Applicant agrees to pay Southwestern Bell Telephone, L.P. for the costs it has incurred in starting performance under the contract and before being notified to cease only.

#### ESTIMATED PRICE QUOTE

The above estimated price is guaranteed for 60 days from December 31, 2003. If the charges are not accepted within 60 days the order will be cancelled and a new order will need to be placed. The second estimate may be higher than the estimated price set out above.

#### CHOICE OF LAW AND ARBITRATION

Should any dispute arise between the parties concerning the subject matter of this agreement, or any term contained therein, the parties agree that the dispute or claim shall be submitted to binding arbitration before the American Arbitration Association. The parties further agree that the prevailing party in any such dispute will be entitled to recover attorney's fees and costs of arbitration.

Texas law governs the application of this agreement and all terms contained therein.

#### INDEMNIFICATION AND HOLD HARMLESS

Applicant, its agents, servants, and employees hereby agree to indemnify and hold harmless SBC, and its employees, agents and contractors, from and against any and all claims, costs, expenses, judgments or actions for damage to property or injury or death to persons, and/or arising from or relating to the work that is the subject of this agreement, to the extent any such claims are caused by the negligent acts or omissions of the Applicant, its agents, servants, or employees.

#### ENTIRE AGREEMENT

The parties agree that the terms set forth herein constitute the entire agreement and there are no other agreements regarding the project that is the subject of this agreement between the parties.

#### MODIFICATION & NOTICE

Any modification to this agreement must be made in writing and signed by both parties.

Any party to this agreement may provide the other party with notice of any fact or condition by providing such information in writing and serving said writing via certified mail, return receipt requested.

8056 Actual Cost

ACCEPTED FOR CUSTOMER:      ACCEPTED FOR SOUTHWESTERN BELL TELEPHONE, L.P.:

\_\_\_\_\_  
Authorized Signature, Title or  
Relationship to Company or Individual  
Company: \_\_\_\_\_

Title: Mgr Oprs-Cntl/CWOTS

Date: \_\_\_\_\_

Date: \_\_\_\_\_

\* Applicable to orders over \$25,000 and work will take 6 or more months to complete.



RR Drainage Trench W view 09/10/09



RR Drainage Channel off ties 09/16/04





*RR Drainage E view trees RR side 09/16/09*



RR Drainage Ways E View 09/16/04

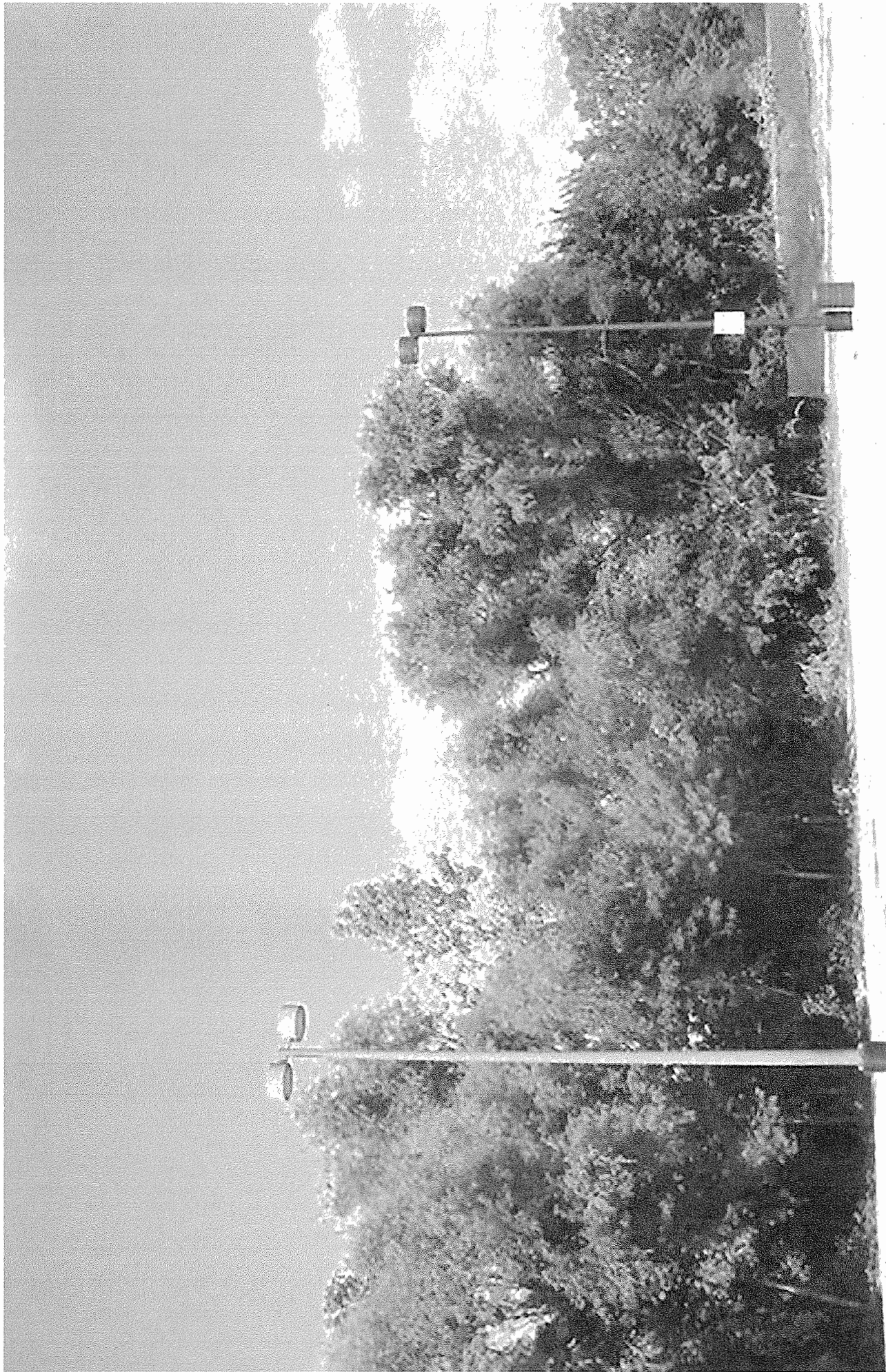

16 3:58 PM



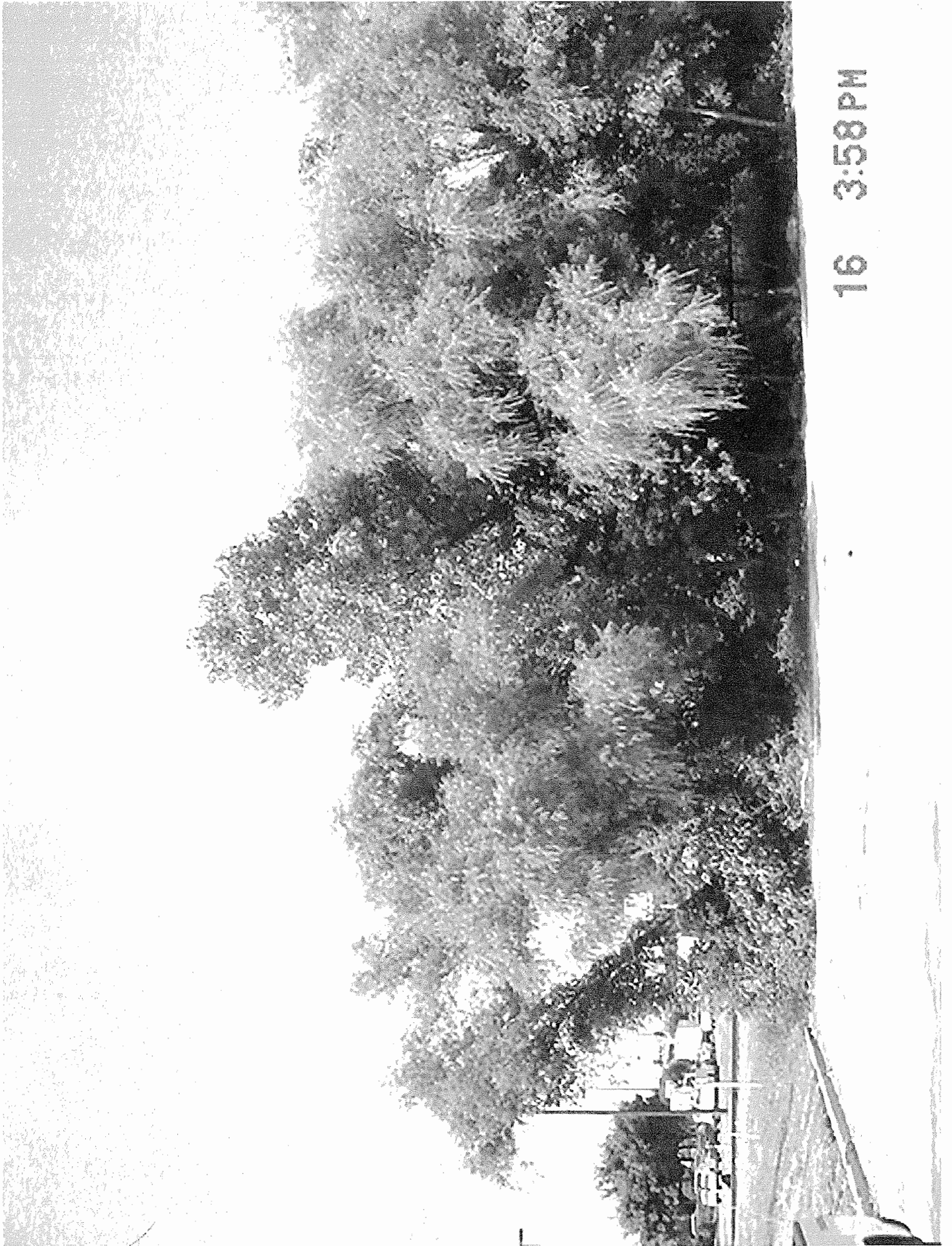

16 3:58 PM

## Steve Chutchian

---

**From:** Katura Curry [kcurry@gra-ce.net]  
**Sent:** Tuesday, February 24, 2004 9:48 AM  
**To:** Mark Smith; Luke Jalbert  
**Cc:** Bruce Grantham; Steve Chutchian  
**Subject:** Arapaho Road Ph 3 - SBC Meeting Summary

Mark and Luke,

I wanted to provide a summary of yesterday's meeting regarding the status of the SBC utilities on the Arapaho Road Phase 3 project.

1. SBC has conflicts that require relocation or further investigation at Midway Road (west side), and west of Midway Road for about 1400 feet along the southern boundary of the project.
2. Mark is going to also check into the possibility of any conflicts at Surveyor with the construction of the new box culverts.
3. Mark indicated that he is not sure of whether SBC has a fiber or conduit on the west side of Midway. He is going to look further into this matter. A conduit is a larger undertaking for relocating. The SBC records indicate a fiber; however, last summer when the area was potholed the notes call out a conduit.
4. Regarding the letter that was sent to the Town about the work to be done and cost for the work, the time and cost quoted are for the design and construction of the utility relocate.
5. Mark said that the 6 months quoted is not a 'hard' type of time line, it will depend on the work to be done. Mark stated that he believes the construction would take 1 to 2 months. But, it still has to go to design.
6. To get the project moving, the Town needs to sign the letter and provide a check to SBC for the cost shown. Luke indicated that this will need to go to Council which will be in about two weeks.
7. Grantham will provide any project information to the Town or SBC that is needed to finalize this relocation process as efficiently as possible.

If any of the above is incorrect or I have missed anything, please let me know.

Thanks,  
Katura

\*\*\*\*\*

Katura Curry, P.E.  
Grantham & Associates, Inc.  
Tel (972) 864-2333  
kcurry@gra-ce.net

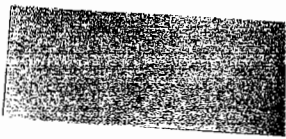

**Steve Chutchian**

---

**From:** K Curry [kcurry@gra-ce.net]  
**Sent:** Wednesday, February 18, 2004 2:30 PM  
**To:** Steve Chutchian  
**Cc:** Luke Jalbert; Bruce Grantham; Jerry Holder  
**Subject:** Arapaho Road Phase 3 - Utility Update

Steve,  
Below is an update of the utilities on the AR 3 project.

Oncor - James Davis  
James has not returned my call. I will continue to try to reach him and update you when I have reached him.

Comcast - Jorge Barrera  
Jorge said that he is meeting with James Davis on-site on Thursday (02/19) to review the relocates. Comcast is located on the Oncor poles at Midway and will be relocating underground. He understands that certain parts of the work are reimbursable by the Town.

MCI - Bob McCoy (Dynamic Technical)  
Waiting for him to call me back with information regarding the MCI / Qwest facilities. He has told me that they have 4 handholds requiring manholes. We are not currently in agreement about where the facilities are or how many handholds there are. We are sharing information so that we both understand the extent of their relocation. He has not been my contact the whole time. He only recently took over the project so he is still trying to come up to speed on what the project includes.

Qwest - Scott Whaley  
Qwest will be contacting the Town regarding an agreement. Dynamic Technical, Bob McCoy, will be performing the necessary field work in conjunction with MCI. There are a combination of 4 handholds that need to be changed into manhole access points.

TXU Gas - Howard Lewis  
Howard is going to review the current storm sewer design to the pothole information that was obtained on the gas lines last summer. I will send over current plans and follow-up in a week or so. Plans were couriered today.

SBC - Mark Smith  
I am sending over (today) the most current storm sewer plans to Mark for his review. He does not have notes regarding how Toby developed the cost which is shown in the letter. I have set up a tentative meeting for **Monday 02/23/04 at 10 am** to bring him up to speed on the project and to get a better understanding of what is going to be done. **Please let me know if you or a Town representative would be available to meet at your office for this meeting.** In the meantime, he will review the plans that I am sending over.

I will continue to contact each company on a weekly basis, or as dictated by the relocation work, and provide you an update periodically. Please let me know if you have any questions.

Thanks,  
Katura

\*\*\*\*\*  
Katura Curry, P.E.  
Grantham & Associates, Inc.  
Tel(972)864-2333  
kcurry@gra-ce.net



**Date:** December 10, 2003

**G&A No.** 320

**To:** Utility Companies

**From:** Bruce Grantham / Katura Curry

**Re:** Utility Conflicts and Relocations - Arapaho Road Phase 3

Notes:

- The franchise utility conflicts and relocations listed in this memo are shown on the attached Sheets 1 and 2. The paving stations and other location references are also shown on these sheets.
- It is understood that franchise utility services to the buildings shown to be demolished prior to the construction of Arapaho Road Phase 3 will need to be disconnected. However, it has not been determined what utilities serve these buildings at this time.
- All conflicts have been placed within one of two categories:
  - ▶ Category 1: Must be relocated to avoid proposed Arapaho Phase 3 improvements.
  - ▶ Category 2: May need to be relocated to avoid proposed Arapaho Phase 3 improvements. In most cases, we anticipate that the franchise utilities would want to relocate the utilities in this category to provide working room for future maintenance.
- *Oncor Conflicts:*
  - Sheet 1 of 2
    - ▶ Power Pole at proposed 8' x 6' box culvert just east of Surveyor (Category 1)
    - ▶ Crossing at station 37 + 80 (Category 1)
    - ▶ Crossing at station 45 + 40 (Category 1)
    - ▶ Crossing at station 47 + 40 (Category 1)
    - ▶ Crossing at station 50 + 40 (Category 1)
    - ▶ Crossing at station 51 + 60 (Category 1)
    - ▶ Crossing at station 55 + 20 (Category 1)
    - ▶ Crossing at Midway Road (west side) (Category 1)
    - ▶ Crossing at Midway Road (east side) (Category 1)
    - ▶ Power Pole at stations 61 + 70 and 62 + 40 (Category 1)
  - Sheet 2 of 2
    - ▶ Power pole at stations 63+10, 63+60, and 64+80 (Category 1)
    - ▶ Crossing at station 86 + 10 (Category 1)



CWOTS # 4185T03  
4801 Matlock Road, Room

B16

Arlington, Texas 76018

December 31, 2003

TOWN OF ADDISON  
P O Box 9010  
Addison, TX 75001

Dear Mr. Jalbert,

This letter is in regards to your request for Southwestern Bell Telephone, L.P. to perform custom work for you. Enclosed please find an Application and Letter of Agency for Custom Work. This application describes the custom work you have requested along with the associated charges for us to do the work. We require an advance payment on this amount, which is shown on the application.

Both the signed application and the advance payment must be received by our office before we can proceed on your behalf. Our mailing address for these documents is listed below:

Southwestern Bell Telephone, L.P.  
Attn: Shirley Meadows  
4801 Matlock Road, Room B16  
Arlington, Texas 76018

If you decide not to proceed with this work, please call our business office so that we may cancel your request. As always, please feel free to contact our business office at 1 800 303-7477 if you have any questions regarding this matter. Please refer to the record number at the top of your application to assist us in locating your file.

Sincerely,

*Shirley Meadows*

Shirley Meadows  
CWOTS Department  
Southwestern Bell Telephone, L.P.  
817 467-8124 or 1-888-321-8535 Phone  
817 467-8198 or 1-800-851-7311 Fax

8056 Actual Cost

ACCEPTED FOR CUSTOMER:

ACCEPTED FOR SOUTHWESTERN BELL TELEPHONE, L.P.:

\_\_\_\_\_  
Authorized Signature, Title or  
Relationship to Company or Individual  
Company: \_\_\_\_\_

\_\_\_\_\_  
Title: Mgr Oprs-Cntl/CWOTS

Date: \_\_\_\_\_

Date: \_\_\_\_\_

\* Applicable to orders over \$25,000 and work will take or more to complete.

Any party to this agreement may provide the other party with notice of any fact or condition by providing such information in writing and serving said writing via certified mail, return receipt requested.



Under no circumstances will SBC's request for a change order be deemed or used as evidence of delay on the project. Nor will any change order issued in this project be used to charge SBC with responsibility for any alleged delay on the project.

#### TIME TO COMPLETE

Any representation by SBC, its agents, servants or employees that the project, or any additional work authorized by change order, will be complete by a certain date or certain time period is strictly an estimate and not binding on SBC, its agents, servants, or employees. All estimated completion dates are subject to changing conditions in the field, changes in the scope of the work, relocation of existing utilities not within SBC's control, Acts of God, weather delays, labor disputes, vendor/contractor disputes, and other conditions or circumstances that SBC, its agents, servants, or employees, could not reasonably anticipate at the time of the estimate.

#### PAYMENT

Applicant agrees to make an advance payment of \$ 44,359.10 prior to commencement of the work and agrees to pay the applicable taxes when the work is completed. Applicable charges for Custom Work will be billed on a special bill separate from the bill that Applicant receives for telephone service.

Applicant, its agents, servants, or employees agree to make payment on change orders within thirty (30) days of the date of signature on the change order. Failure to make payment within the designated thirty (30) day time period will operate to cancel the change order and SBC will cease all work activity on the project until payment is made.

When the Applicant agrees to Interval Billing \*, the balance of the Contract Price or Actual Cost (as applicable) will be made in monthly payments. If the Actual Cost made varies from the Estimated Cost, then a correcting adjustment will be made in the last payment.

#### CANCELLATION

If the applicant cancels the work prior to completion, Applicant agrees to pay Southwestern Bell Telephone, L.P. for the costs it has incurred in starting performance under the contract and before being notified to cease only.

#### ESTIMATED PRICE QUOTE

The above estimated price is guaranteed for 60 days from December 31, 2003. If the charges are not accepted within 60 days the order will be cancelled and a new order will need to be placed. The second estimate may be higher than the estimated price set out above.

#### CHOICE OF LAW AND ARBITRATION

Should any dispute arise between the parties concerning the subject matter of this agreement, or any term contained therein, the parties agree that the dispute or claim shall be submitted to binding arbitration before the American Arbitration Association. The parties further agree that the prevailing party in any such dispute will be entitled to recover attorney's fees and costs of arbitration.

Texas law governs the application of this agreement and all terms contained therein.

#### INDEMNIFICATION AND HOLD HARMLESS

Applicant, its agents, servants, and employees hereby agree to indemnify and hold harmless SBC, and its employees, agents and contractors, from and against any and all claims, costs, expenses, judgments or actions for damage to property or injury or death to persons, and/or arising from or relating to the work that is the subject of this agreement, to the extent any such claims are caused by the negligent acts or omissions of the Applicant, its agents, servants, or employees.

#### ENTIRE AGREEMENT

The parties agree that the terms set forth herein constitute the entire agreement and there are no other agreements regarding the project that is the subject of this agreement between the parties.

#### MODIFICATION & NOTICE

Any modification to this agreement must be made in writing and signed by both parties.

## APPLICATION and LETTER OF AGENCY FOR CUSTOM WORK

December 31, 2003

CWOTS Number: 4185T03

Customer Billing Telephone Number: 972 450-7000

**BILL TO:** TOWN OF ADDISON  
P O Box 9010  
Addison, TX 75001

### DESCRIPTION OF CUSTOM WORK:

This cost estimate is for the extension of Arapaho Road from Surveyor Road to Addison Road. This job will reroute conduit run under new box culvert. Contract engineer will design job.

**CHARGE FOR CUSTOM WORK:**

**ESTIMATED COST: \$ 44,359.10+ tax**

(Actual charges may exceed this estimated cost.)

\*\*\*IF USING A PURCHASE ORDER ESTIMATED COST WILL BE \$45,124.75\*\*\*

**ESTIMATED LABOR: \$ 34,064.31; ESTIMATED MATERIALS: \$ 6,128.88;**

**ESTIMATED OVERHEAD EXPENSE: \$ 4,165.91**

Applicant requests that Southwestern Bell Telephone, L.P. act as its agent in performing the above-described custom work on Applicant's behalf. Applicant agrees to pay the charge(s) indicated above for such work. The work is to be done on an "Actual Cost" basis, all charge(s) will be computed in accordance with Southwestern Bell Corporation's ordinary accounting practices under the Uniform System of Accounts for Class A telephone companies and will include allocated costs for labor, engineering, materials, transportation, motor vehicles, tool and supply expenses and sundry billings from sub-contractors and suppliers for work and materials related to the job. The Applicant affirms that the cost estimate furnished by the Telephone Company has been considered only as an estimate of approximate costs and that the actual costs incurred by the Telephone Company in doing the work at the particular time and location might be higher. Said estimated cost is subject to change due to any number of factors including, but not limited to, changing conditions in the field, weather delays, or changes in the scope of the work.

### CHANGE ORDERS

Should concealed conditions exist, including conditions that may exist below the surface of the ground, or if conditions exist that could not have been anticipated by SBC at the time of this agreement, SBC will be entitled to additional funds and/or additional time to complete the work. SBC will request such additional funding and/or additional time through a request for a change order.

Should Applicant or its agents, servants, or employees order or seek changes in the scope of the work, SBC is entitled to seek from Applicant, its agents, servants, or employees, additional funds as necessary to perform the work, and additional time, as necessary to complete the work. Said request for additional funds and/or additional time will be through change order.

All change orders will be in writing.

All change orders will be submitted and accepted by Applicant, its agents, servants or employees, before SBC proceeds to execute the work or, if work has been initiated on the project, continues with executing the work except in an emergency endangering life or property.

Applicant, its agents, servants or employees, are deemed to have accepted the terms of any change order by signing where indicated on the change order.

8056 Actual Cost



**Date:** December 10, 2003 **G&A No. 320**  
**To:** Utility Companies  
**From:** Bruce Grantham / Katura Curry  
**Re:** Utility Conflicts and Relocations - Arapaho Road Phase 3

---

Notes:

- The franchise utility conflicts and relocations listed in this memo are shown on the attached Sheets 1 and 2. The paving stations and other location references are also shown on these sheets.
- It is understood that franchise utility services to the buildings shown to be demolished prior to the construction of Arapaho Road Phase 3 will need to be disconnected. However, it has not been determined what utilities serve these buildings at this time.
- All conflicts have been placed within one of two categories:
  - ▶ Category 1: Must be relocated to avoid proposed Arapaho Phase 3 improvements.
  - ▶ Category 2: May need to be relocated to avoid proposed Arapaho Phase 3 improvements. In most cases, we anticipate that the franchise utilities would want to relocate the utilities in this category to provide working room for future maintenance.
- *Oncor Conflicts:*
  - Sheet 1 of 2
    - ▶ Power Pole at proposed 8' x 6' box culvert just east of Surveyor (Category 1)
    - ▶ Crossing at station 37 + 80 (Category 1)
    - ▶ Crossing at station 45 + 40 (Category 1)
    - ▶ Crossing at station 47 + 40 (Category 1)
    - ▶ Crossing at station 50 + 40 (Category 1)
    - ▶ Crossing at station 51 + 60 (Category 1)
    - ▶ Crossing at station 55 + 20 (Category 1)
    - ▶ Crossing at Midway Road (west side) (Category 1)
    - ▶ Crossing at Midway Road (east side) (Category 1)
    - ▶ Power Pole at stations 61 + 70 and 62 + 40 (Category 1)
  - Sheet 2 of 2
    - ▶ Power pole at stations 63+10, 63+60, and 64+80 (Category 1)
    - ▶ Crossing at station 86 + 10 (Category 1)

- *TxU Gas Conflicts:*  
Sheet 1 of 2
  - ▶ Crossing at Surveyor Boulevard (west side) at proposed box culvert (Category 2)
  - ▶ Crossing at Midway Road (west side) (Category 2)
  
- *SBC Conflicts:*  
Sheet 1 of 2
  - ▶ Crossing at Surveyor Boulevard (west side) at proposed box culvert (Category 2)
  - ▶ Crossing at Surveyor Boulevard (east side) at proposed box culvert (Category 2)
  - ▶ Parallel conflict station 51 + 00 to west side of Midway Road (Category 1)
  - ▶ Crossing at Midway Road (west side) (Category 2)
  - ▶ Crossing at Midway Road (east side) (Category 2)
  
- *MCI*  
Sheet 2 of 2
  - ▶ Parallel conflict station 76 + 60 to 85 + 80 (Category 2)
  
- *Qwest*  
Sheet 2 of 2
  - ▶ Parallel conflict station 76 + 60 to 85 + 80 (Category 2)

1022  
313060

NO.	DATE	REVISION	APPROV.
1			
2			
3			

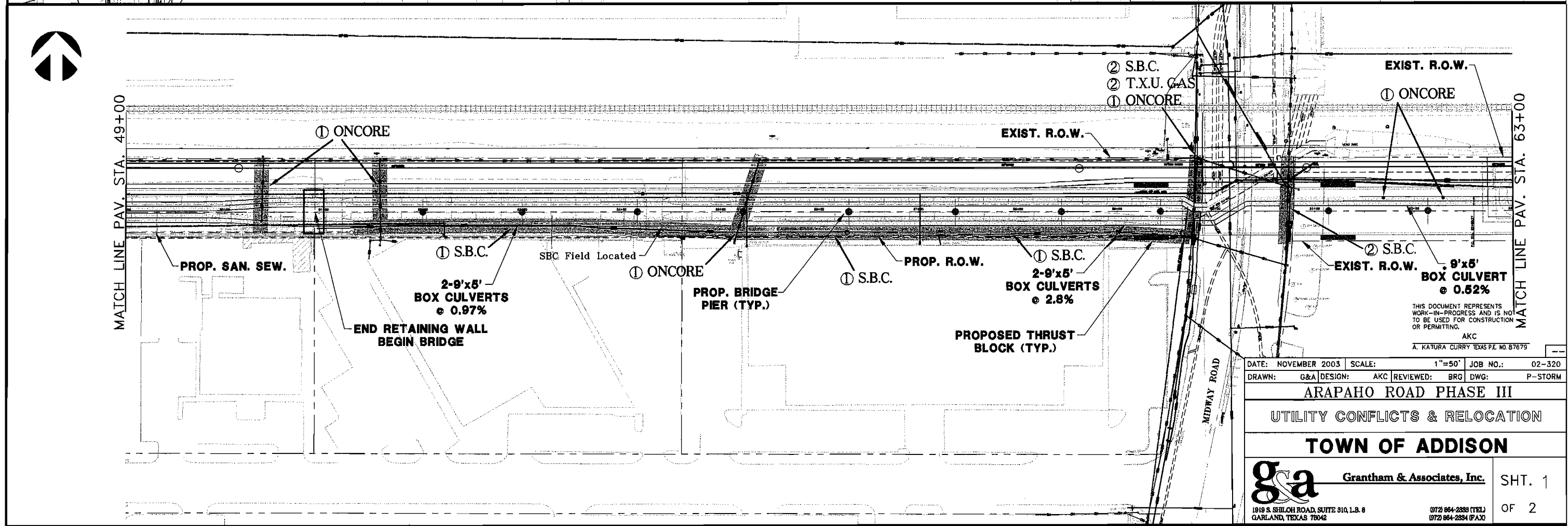
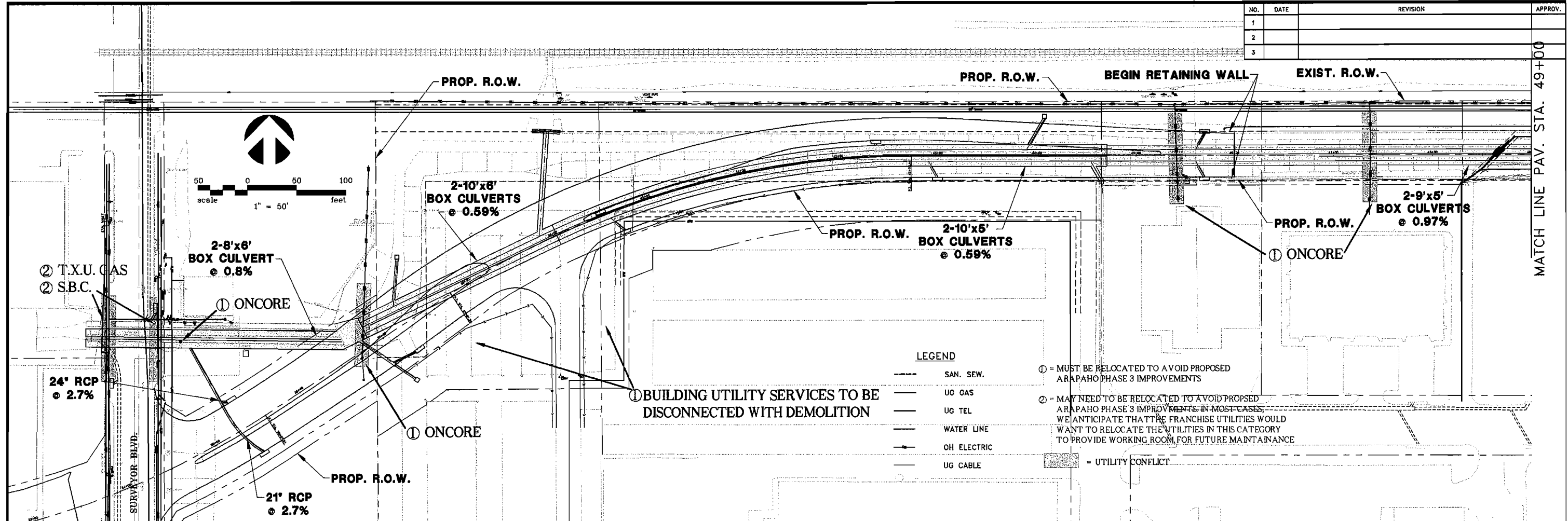

DATE: NOVEMBER 2003	SCALE: 1"=50'	JOB NO.: 02-320
DRAWN: G&A	DESIGN: AKC	REVIEWED: BRG
ARAPAHO ROAD PHASE III		
UTILITY CONFLICTS & RELOCATION		
TOWN OF ADDISON		
Grantham & Associates, Inc.		SHT. 1
1919 S. SHILOH ROAD, SUITE 310, L.B. 8 GARLAND, TEXAS 75042		OF 2
(972) 864-2888 (TEL) (972) 864-2834 (FAX)		

NO.	DATE	REVISION	APPROV.
1			
2			
3			

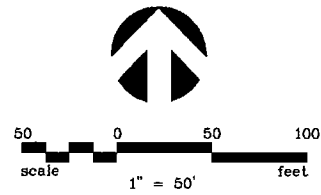

**LEGEND**

- SAN. SEW.
  - UG GAS
  - UG TEL
  - WATER LINE
  - OH ELECTRIC
  - UG CABLE
- ① = MUST BE RELOCATED TO AVOID PROPOSED ARAPAHO PHASE 3 IMPROVEMENTS
  - ② = MAY NEED TO BE RELOCATED TO AVOID PROPOSED ARAPAHO PHASE 3 IMPROVEMENTS. IN MOST CASES, WE ANTICIPATE THAT THE FRANCHISE UTILITIES WOULD WANT TO RELOCATE THE UTILITIES IN THIS CATEGORY TO PROVIDE WORKING ROOM FOR FUTURE MAINTAINANCE
  - [Hatched Box] = UTILITY CONFLICT

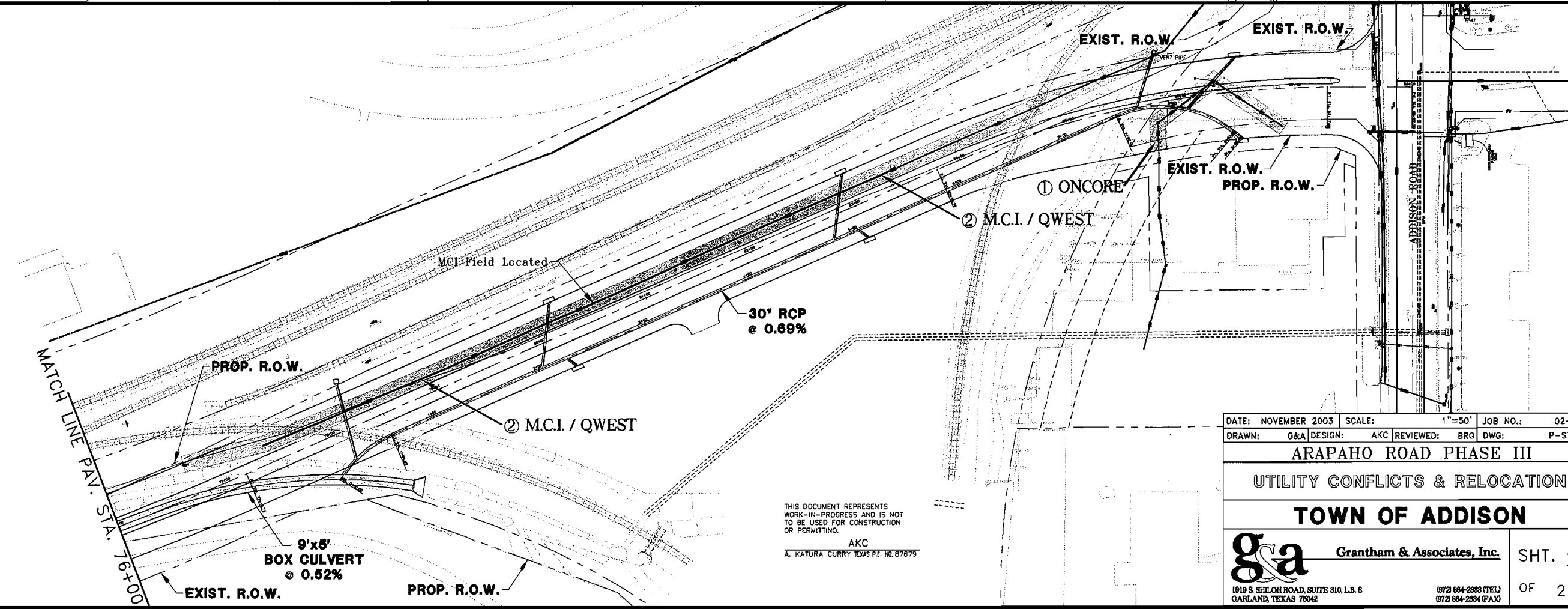
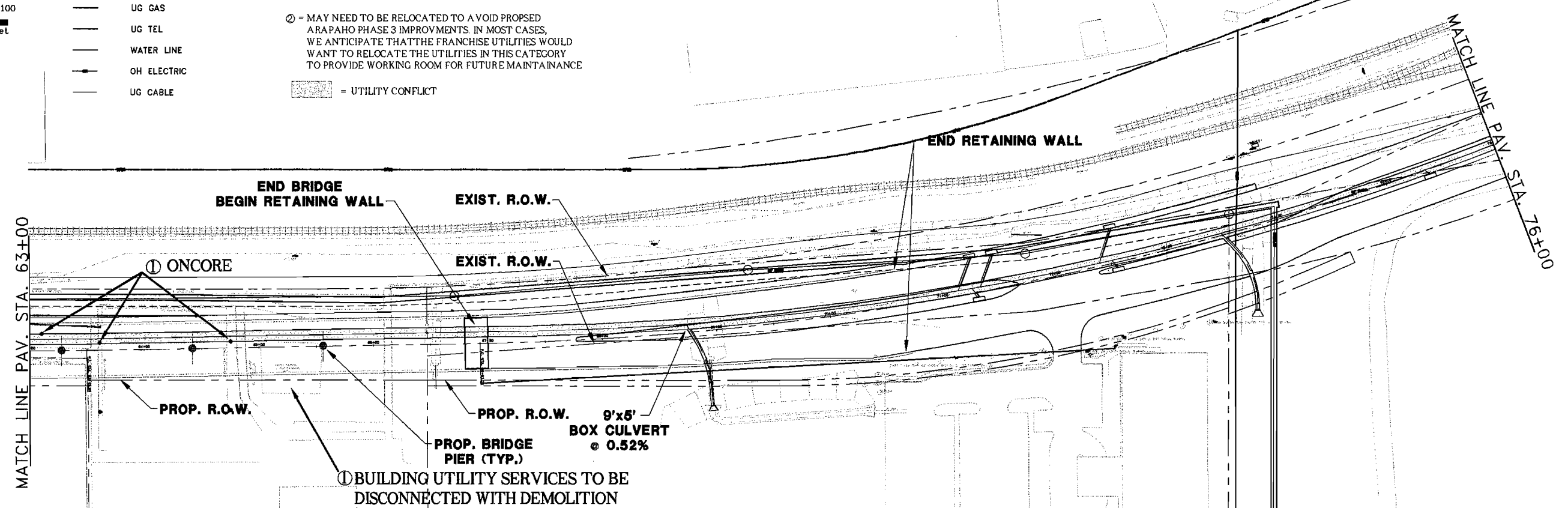

THIS DOCUMENT REPRESENTS WORK-IN-PROGRESS AND IS NOT TO BE USED FOR CONSTRUCTION OR PERMITTING.

AKC  
A. KATURA CURRY TEXAS P.E. NO. 87679

DATE: NOVEMBER 2003	SCALE: 1"=50'	JOB NO.: 02-320
DRAWN: G&A	DESIGN: AKC	REVIEWED: BRG
	DWG: P-STORM	

**ARAPAHO ROAD PHASE III**

**UTILITY CONFLICTS & RELOCATION**

**TOWN OF ADDISON**



1919 S. SHILOH ROAD, SUITE 310, L.B. 8 GARLAND, TEXAS 75042

Grantham & Associates, Inc.

(972) 664-2333 (TEL)  
(972) 664-2334 (FAX)

SHT. 2

OF 2

## Steve Chutchian

---

**From:** Clarence West [cawest@cawestlaw.com]  
**Sent:** Thursday, February 26, 2004 8:10 PM  
**To:** Bruce Grantham; Steve Chutchian; Clarence West; Mike Murphy; Luke Jalbert; Jim Pierce; Angela Washington  
**Cc:** Jenny Nicewander; Jerry Holder; Katura Curry  
**Subject:** Re: Arapaho Road 3 - Franchise Utility Relocation Reimbursement Status

Bruce,

You are generally correct. If the utility is in a dedicated utility easement, not a private one, or in an alleyway or other publicly dedicated property, then they may have to move at the utility's cost. It is only when they are in a private easement that the franchise would not apply. As to telephone and electric, if it is not a widening and/or straightening of a road, they will challenge having to move at their cost.

----- Bruce Grantham <bgrantham@gra-ce.net> wrote:

> I spoke with Angela today at Luke's request regarding the status of the  
> above referenced project.  
> For clarification purposes, here is my understanding of where this matter  
> stands:  
>  
> - Clarence recently informed the Town that their franchise agreements can  
> only be used to require the affected utility companies to relocate their  
> facilities at no expense to the Town where they fall within an existing  
> right-of-way. (e.g. Midway Road).  
> - Within the limits of the new right-of-way acquired by the Town for Arapaho  
> Road 3, the Town will need to reimburse the franchise companies for their  
> relocation expenses.  
> - The franchise companies are currently working on their relocation costs,  
> except for SBC who has already furnished a cost to the Town.  
> - We were unable to find existing easements for all the affected franchise  
> utilities in the title documents furnished to our office by Angela for the  
> Arapaho 3 right-of-way acquisitions.  
> - However, given the information provided by Clarence, there does not appear  
> to be a compelling reason to request that the franchise companies furnish us  
> with copies of their easements, which would be our only other source of  
> these documents.  
>  
> Please let me know if my understanding of the status of this matter is  
> incorrect.  
>  
> Thanks, Bruce  
>  
>  
>

Clarence A. West  
1201 Rio Grande Street, Suite 200  
Austin, Texas  
78701

512-499-8838  
fax: 512-322-8884

## Steve Chutchian

---

**From:** Katura Curry [kcurry@gra-ce.net]  
**Sent:** Tuesday, February 24, 2004 9:48 AM  
**To:** Mark Smith; Luke Jalbert  
**Cc:** Bruce Grantham; Steve Chutchian  
**Subject:** Arapaho Road Ph 3 - SBC Meeting Summary

Mark and Luke,

I wanted to provide a summary of yesterday's meeting regarding the status of the SBC utilities on the Arapaho Road Phase 3 project.

1. SBC has conflicts that require relocation or further investigation at Midway Road (west side), and west of Midway Road for about 1400 feet along the southern boundary of the project.
2. Mark is going to also check into the possibility of any conflicts at Surveyor with the construction of the new box culverts.
3. Mark indicated that he is not sure of whether SBC has a fiber or conduit on the west side of Midway. He is going to look further into this matter. A conduit is a larger undertaking for relocating. The SBC records indicate a fiber; however, last summer when the area was potholed the notes call out a conduit.
4. Regarding the letter that was sent to the Town about the work to be done and cost for the work, the time and cost quoted are for the design and construction of the utility relocate.
5. Mark said that the 6 months quoted is not a 'hard' type of time line, it will depend on the work to be done. Mark stated that he believes the construction would take 1 to 2 months. But, it still has to go to design.
6. To get the project moving, the Town needs to sign the letter and provide a check to SBC for the cost shown. Luke indicated that this will need to go to Council which will be in about two weeks.
7. Grantham will provide any project information to the Town or SBC that is needed to finalize this relocation process as efficiently as possible.

If any of the above is incorrect or I have missed anything, please let me know.

Thanks,  
Katura

\*\*\*\*\*

Katura Curry, P.E.  
Grantham & Associates, Inc.  
Tel (972) 864-2333  
kcurry@gra-ce.net



## Steve Chutchian

---

**From:** Bruce Grantham [bgrantham@gra-ce.net]  
**Sent:** Thursday, February 26, 2004 3:37 PM  
**To:** Steve Chutchian; Clarence West; Mike Murphy; Luke Jalbert; Jim Pierce; Angela Washington  
**Cc:** Jenny Nicewander; Jerry Holder; Katura Curry  
**Subject:** Arapaho Road 3 - Franchise Utility Relocation Reimbursement Status

I spoke with Angela today at Luke's request regarding the status of the above referenced project.  
For clarification purposes, here is my understanding of where this matter stands:

- Clarence recently informed the Town that their franchise agreements can only be used to require the affected utility companies to relocate their facilities at no expense to the Town where they fall within an existing right-of-way. (e.g. Midway Road).
- Within the limits of the new right-of-way acquired by the Town for Arapaho Road 3, the Town will need to reimburse the franchise companies for their relocation expenses.
- The franchise companies are currently working on their relocation costs, except for SBC who has already furnished a cost to the Town.
- We were unable to find existing easements for all the affected franchise utilities in the title documents furnished to our office by Angela for the Arapaho 3 right-of-way acquisitions.
- However, given the information provided by Clarence, there does not appear to be a compelling reason to request that the franchise companies furnish us with copies of their easements, which would be our only other source of these documents.

Please let me know if my understanding of the status of this matter is incorrect.

Thanks, Bruce

**Steve Chutchian**

---

**From:** K Curry [kcurry@gra-ce.net]  
**Sent:** Wednesday, February 18, 2004 2:30 PM  
**To:** Steve Chutchian  
**Cc:** Luke Jalbert; Bruce Grantham; Jerry Holder  
**Subject:** Arapaho Road Phase 3 - Utility Update

Steve,  
 Below is an update of the utilities on the AR 3 project.

**Oncor - James Davis**  
 James has not returned my call. I will continue to try to reach him and update you when I have reached him.

**Comcast - Jorge Barrera**  
 Jorge said that he is meeting with James Davis on-site on Thursday (02/19) to review the relocations. Comcast is located on the Oncor poles at Midway and will be relocating underground. He understands that certain parts of the work are reimbursable by the Town.

**MCI - Bob McCoy (Dynamic Technical)**  
 Waiting for him to call me back with information regarding the MCI / Qwest facilities. He has told me that they have 4 handholds requiring manholes. We are not currently in agreement about where the facilities are or how many handholds there are. We are sharing information so that we both understand the extent of their relocation. He has not been my contact the whole time. He only recently took over the project so he is still trying to come up to speed on what the project includes.

**Qwest - Scott Whaley**  
 Qwest will be contacting the Town regarding an agreement. Dynamic Technical, Bob McCoy, will be performing the necessary field work in conjunction with MCI. There are a combination of 4 handholds that need to be changed into manhole access points.

**TXU Gas - Howard Lewis**  
 Howard is going to review the current storm sewer design to the pothole information that was obtained on the gas lines last summer. I will send over current plans and follow-up in a week or so. Plans were couriered today.

**SBC - Mark Smith**  
 I am sending over (today) the most current storm sewer plans to Mark for his review. He does not have notes regarding how Toby developed the cost which is shown in the letter. I have set up a tentative meeting for **Monday 02/23/04 at 10 am** to bring him up to speed on the project and to get a better understanding of what is going to be done. **Please let me know if you or a Town representative would be available to meet at your office for this meeting.** In the meantime, he will review the plans that I am sending over.

I will continue to contact each company on a weekly basis, or as dictated by the relocation work, and provide you an update periodically. Please let me know if you have any questions.

Thanks,  
 Katura

\*\*\*\*\*  
 Katura Curry, P.E.  
 Grantham & Associates, Inc.  
 Tel(972)864-2333  
 kcurry@gra-ce.net

2/20/2004

25th  
Anniversary  
1978-2003

# COWLES & THOMPSON

A Professional Corporation  
ATTORNEYS AND COUNSELORS



ANGELA K. WASHINGTON  
214.672.2144  
AWASHINGTON@COWLESTHOMPSON.COM

January 23, 2004

**VIA HAND DELIVERY**

Mr. Matt Kirk  
Grantham & Associates, Inc.  
1919 S. Shiloh Road, Suite 310  
Garland, TX 75042

**RE: Town of Addison - Arapaho Extension of Road Project  
(Utility Relocation)**

Dear Mr. Kirk:

Pursuant to your request, enclosed are the documents referenced in the Schedule Bs for the Arapaho Road Parcels forwarded to your office via facsimile last month. Please let me know if you need anything further. Thank you for your assistance in this matter.

Sincerely,

Angela K. Washington

AKW/yjr  
Enclosures

c(w/o Enclosures): Mr. Bruce Grantham  
Mr. Mike Murphy, w/Town  
Mr. Steve Chutchian, w/Town  
Mr. Kenneth C. Dippel, w/firm

## Steve Chutchian

---

**From:** B Grantham [bgrantham@gra-ce.net]  
**Sent:** Tuesday, January 20, 2004 6:41 PM  
**To:** Steve Chutchian; Luke Jalbert; Jim Pierce; Mike Murphy  
**Cc:** Katura Curry; Jenny Nicewander; Jerry Holder  
**Subject:** Arapaho 3 Oncor Update

I spoke with James Davis today in order to get a heads up on the project status heading into Thursday's meeting. Below is a summary of our conversation:

1. James and Randy will attend the meeting on Oncor's behalf.
2. Randy will present his reasoning for not offering to partner in the project relocation cost. To change this decision, the Town will need to approach a higher authority at Oncor.
3. The Town will save significant dollars by having the Arapaho 3 contractor install Oncor's street crossing conduits by open cut, rather than having Oncor bore them.
4. Having the Town pay an electrician directly for reconnecting services between the transformers and the buildings will also reduce Oncor's bill.
5. James is waiting for Luke to schedule an on-site meeting with an electrician of the Town's choosing to ensure that there will not be a problem reconnecting these services.
6. Once he has met with the electrician, James anticipates that he will have a relocation cost estimate prepared in about 30 days.
7. He anticipates that a major portion of the cost that Oncor will pass onto the Town will be putting their existing primary feed in Midway underground. (Oncor will subtract the cost of relocating their service, but remaining overhead, from the pass through cost to Addison).
8. As the crossings of Arapaho 3 are all secondary services, James does not anticipate as big a cost here.
9. He will be providing us with stations for three new service crossings of Midway; one 6" conduit for Charter Furniture, one 4" conduit near Midway for the bridge lighting, and one 4" conduit near Surveyor for the road lighting.
10. G&A compared the location of Oncor's existing poles with the proposed underground utilities (e.g. storm & sanitary sewers) and only one pole is in conflict (the third service west of Midway). At this pole, Oncor will need to install a temporary pole outside the conflict limits, or the Arapaho 3 contractor will have to get Oncor's conduit in first, so that service can be maintained to the building during construction. At all the other crossings, Oncor's overhead service can remain in place until all the Arapaho 3 underground utilities and conduit is in.
11. G&A will bring proposed Oncor conduit profiles to the Thursday meeting.
12. Oncor wants 3-foot of cover over their line and 1-foot of clearance to other utilities.
13. DWU wants 5-foot of clearance between their water main and Oncor's conduit.
14. James is assuming that the existing overhead line along the DART R.O.W. line, which carries a primary feed, will remain overhead. Putting this line underground would be a big ticket item in his opinion.

We notified Angela last week that their firm sent us Schedule B only from the title commitments for Arapaho 3, and that we do not have the easement documents to review. I spoke with her today and she said she would send the easements over to us.

James has been primarily coordinating with Katura on this project. Due to an unanticipated conflict, I will be unable to attend Thursday's meeting, however, Katura will attend.

I will be in the office around 10 a.m. Wednesday morning if you have any

**Steve Chutchian**

---

**From:** B Grantham [bgrantham@gra-ce.net]  
**Sent:** Wednesday, January 21, 2004 10:05 AM  
**To:** Katura Curry  
**Cc:** Mike Murphy; Steve Chutchian; Luke Jalbert; Jim Pierce  
**Subject:** FW: ADDITIONAL CROSSINGS FOR ARAPAHO ROAD 3

-----Original Message-----

From: JDAVIS4@oncorgroup.com [mailto:JDAVIS4@oncorgroup.com]  
Sent: Tuesday, January 20, 2004 7:27 PM  
To: bgrantham@gra-ce.net  
Subject: ADDITIONAL CROSSINGS FOR ARAPAHO ROAD 3

Bruce,

The following are the station numbers for the additional conduit crossings for the road and bridge lighting and the service to Charter Furniture.

(1) Arapaho Rd street lights source ( Surveyor to beginning of Bridge on west side of Midway)                    STA. 44+39                    1-2"PVC SCH 40 conduit

(2) Bridge lighting  
STA. 57+90                    1-2"PVC SCH 40 conduit

(3) Charter Furniture  
STA 58+87                    6" PVC SCH 40 (number to be determined)

The service to Charter will cross perpendicular from the pole line which parallels the DWU water line through the entire road r.o.w. These will be 6" conduits and I will let you know the number. The crossings for the bridge and roadway lighting will be one 2" pvc conduit for each crossing for a total of two conduits and each will only go just a few feet short of the paved area of the road on the north side, therefore, crossing the DWU pipe is the only facility I know of that will be an issue. For the lighting conduits we would need only the appropriate fill over the DWU pipe in order to install the pipes. These pipes require 2' of cover. The 6" pipes for Charter need 2' of cover since these cables, like the lighting ones, are at lower voltage. The 4" pipes for the primary crossings (13 kilo volts) which we've already talked about require 3' of cover. All cover should be at final grade. By our requirements there should be one foot of separation between our conduits and any other underground conduits, culverts, etc. Of course, DWU has communicated their own five foot separation requirement to me. Please contact me for any clarification or further discussion,

Regards,  
James Davis

\*\*\*\*\*  
\*\*\*\*\*

Confidentiality Notice: This email message, including any attachments, contains or may contain confidential information intended only for the addressee. If you are not an intended recipient of this message, be advised that any reading, dissemination, forwarding, printing, copying

CWOTS # 4185T03  
4801 Matlock Road, Room

B16

Arlington, Texas 76018

December 31, 2003

TOWN OF ADDISON  
P O Box 9010  
Addison, TX 75001

Dear Mr. Jalbert,

This letter is in regards to your request for Southwestern Bell Telephone, L.P. to perform custom work for you. Enclosed please find an Application and Letter of Agency for Custom Work. This application describes the custom work you have requested along with the associated charges for us to do the work. We require an advance payment on this amount, which is shown on the application.

Both the signed application and the advance payment must be received by our office before we can proceed on your behalf. Our mailing address for these documents is listed below:

Southwestern Bell Telephone, L.P.  
Attn: Shirley Meadows  
4801 Matlock Road, Room B16  
Arlington, Texas 76018

If you decide not to proceed with this work, please call our business office so that we may cancel your request. As always, please feel free to contact our business office at 1 800 303-7477 if you have any questions regarding this matter. Please refer to the record number at the top of your application to assist us in locating your file.

Sincerely,

*Shirley Meadows*

Shirley Meadows  
CWOTS Department  
Southwestern Bell Telephone, L.P.  
817 467-8124 or 1-888-321-8535 Phone  
817 467-8198 or 1-800-851-7311 Fax

8056 Actual Cost

ACCEPTED FOR CUSTOMER:

ACCEPTED FOR SOUTHWESTERN BELL TELEPHONE, L.P.:

\_\_\_\_\_  
Authorized Signature, Title or  
Relationship to Company or Individual  
Company: \_\_\_\_\_

\_\_\_\_\_  
Title: Mgr Oprs-Cntl/CWOTS

Date: \_\_\_\_\_

Date: \_\_\_\_\_

\* Applicable to orders over \$25,000 and work will take or more to complete.

Any party to this agreement may provide the other party with notice of any fact or condition by providing such information in writing and serving said writing via certified mail, return receipt requested.



Under no circumstances will SBC's request for a change order be deemed or used as evidence of delay on the project. Nor will any change order issued in this project be used to charge SBC with responsibility for any alleged delay on the project.

#### TIME TO COMPLETE

Any representation by SBC, its agents, servants or employees that the project, or any additional work authorized by change order, will be complete by a certain date or certain time period is strictly an estimate and not binding on SBC, its agents, servants, or employees. All estimated completion dates are subject to changing conditions in the field, changes in the scope of the work, relocation of existing utilities not within SBC's control, Acts of God, weather delays, labor disputes, vendor/contractor disputes, and other conditions or circumstances that SBC, its agents, servants, or employees, could not reasonably anticipate at the time of the estimate.

#### PAYMENT

Applicant agrees to make an advance payment of \$ 44,359.10 prior to commencement of the work and agrees to pay the applicable taxes when the work is completed. Applicable charges for Custom Work will be billed on a special bill separate from the bill that Applicant receives for telephone service.

Applicant, its agents, servants, or employees agree to make payment on change orders within thirty (30) days of the date of signature on the change order. Failure to make payment within the designated thirty (30) day time period will operate to cancel the change order and SBC will cease all work activity on the project until payment is made.

When the Applicant agrees to Interval Billing \*, the balance of the Contract Price or Actual Cost (as applicable) will be made in monthly payments. If the Actual Cost made varies from the Estimated Cost, then a correcting adjustment will be made in the last payment.

#### CANCELLATION

If the applicant cancels the work prior to completion, Applicant agrees to pay Southwestern Bell Telephone, L.P. for the costs it has incurred in starting performance under the contract and before being notified to cease only.

#### ESTIMATED PRICE QUOTE

The above estimated price is guaranteed for 60 days from December 31, 2003. If the charges are not accepted within 60 days the order will be cancelled and a new order will need to be placed. The second estimate may be higher than the estimated price set out above.

#### CHOICE OF LAW AND ARBITRATION

Should any dispute arise between the parties concerning the subject matter of this agreement, or any term contained therein, the parties agree that the dispute or claim shall be submitted to binding arbitration before the American Arbitration Association. The parties further agree that the prevailing party in any such dispute will be entitled to recover attorney's fees and costs of arbitration.

Texas law governs the application of this agreement and all terms contained therein.

#### INDEMNIFICATION AND HOLD HARMLESS

Applicant, its agents, servants, and employees hereby agree to indemnify and hold harmless SBC, and its employees, agents and contractors, from and against any and all claims, costs, expenses, judgments or actions for damage to property or injury or death to persons, and/or arising from or relating to the work that is the subject of this agreement, to the extent any such claims are caused by the negligent acts or omissions of the Applicant, its agents, servants, or employees.

#### ENTIRE AGREEMENT

The parties agree that the terms set forth herein constitute the entire agreement and there are no other agreements regarding the project that is the subject of this agreement between the parties.

#### MODIFICATION & NOTICE

Any modification to this agreement must be made in writing and signed by both parties.

## APPLICATION and LETTER OF AGENCY FOR CUSTOM WORK

December 31, 2003

CWOTS Number: 4185T03

Customer Billing Telephone Number: 972 450-7000

**BILL TO:** TOWN OF ADDISON  
P O Box 9010  
Addison, TX 75001

### DESCRIPTION OF CUSTOM WORK:

This cost estimate is for the extension of Arapaho Road from Surveyor Road to Addison Road. This job will reroute conduit run under new box culvert. Contract engineer will design job.

**CHARGE FOR CUSTOM WORK:** ESTIMATED COST: \$ 44,359.10+ tax  
(Actual charges may exceed this estimated cost.)  
\*\*\*IF USING A PURCHASE ORDER ESTIMATED COST WILL BE \$45,124.75\*\*\*  
**ESTIMATED LABOR: \$ 34,064.31; ESTIMATED MATERIALS: \$ 6,128.88;**  
**ESTIMATED OVERHEAD EXPENSE: \$ 4,165.91**

Applicant requests that Southwestern Bell Telephone, L.P. act as its agent in performing the above-described custom work on Applicant's behalf. Applicant agrees to pay the charge(s) indicated above for such work. The work is to be done on an "Actual Cost" basis, all charge(s) will be computed in accordance with Southwestern Bell Corporation's ordinary accounting practices under the Uniform System of Accounts for Class A telephone companies and will include allocated costs for labor, engineering, materials, transportation, motor vehicles, tool and supply expenses and sundry billings from sub-contractors and suppliers for work and materials related to the job. The Applicant affirms that the cost estimate furnished by the Telephone Company has been considered only as an estimate of approximate costs and that the actual costs incurred by the Telephone Company in doing the work at the particular time and location might be higher. Said estimated cost is subject to change due to any number of factors including, but not limited to, changing conditions in the field, weather delays, or changes in the scope of the work.

### CHANGE ORDERS

Should concealed conditions exist, including conditions that may exist below the surface of the ground, or if conditions exist that could not have been anticipated by SBC at the time of this agreement, SBC will be entitled to additional funds and/or additional time to complete the work. SBC will request such additional funding and/or additional time through a request for a change order.

Should Applicant or its agents, servants, or employees order or seek changes in the scope of the work, SBC is entitled to seek from Applicant, its agents, servants, or employees, additional funds as necessary to perform the work, and additional time, as necessary to complete the work. Said request for additional funds and/or additional time will be through change order.

All change orders will be in writing.

All change orders will be submitted and accepted by Applicant, its agents, servants or employees, before SBC proceeds to execute the work or, if work has been initiated on the project, continues with executing the work except in an emergency endangering life or property.

Applicant, its agents, servants or employees, are deemed to have accepted the terms of any change order by signing where indicated on the change order.

8056 Actual Cost



**Date:** December 10, 2003 **G&A No. 320**  
**To:** Utility Companies  
**From:** Bruce Grantham / Katura Curry  
**Re:** Utility Conflicts and Relocations - Arapaho Road Phase 3

---

Notes:

- The franchise utility conflicts and relocations listed in this memo are shown on the attached Sheets 1 and 2. The paving stations and other location references are also shown on these sheets.
- It is understood that franchise utility services to the buildings shown to be demolished prior to the construction of Arapaho Road Phase 3 will need to be disconnected. However, it has not been determined what utilities serve these buildings at this time.
- All conflicts have been placed within one of two categories:
  - ▶ Category 1: Must be relocated to avoid proposed Arapaho Phase 3 improvements.
  - ▶ Category 2: May need to be relocated to avoid proposed Arapaho Phase 3 improvements. In most cases, we anticipate that the franchise utilities would want to relocate the utilities in this category to provide working room for future maintenance.
- *Oncor Conflicts:*
  - Sheet 1 of 2
    - ▶ Power Pole at proposed 8' x 6' box culvert just east of Surveyor (Category 1)
    - ▶ Crossing at station 37 + 80 (Category 1)
    - ▶ Crossing at station 45 + 40 (Category 1)
    - ▶ Crossing at station 47 + 40 (Category 1)
    - ▶ Crossing at station 50 + 40 (Category 1)
    - ▶ Crossing at station 51 + 60 (Category 1)
    - ▶ Crossing at station 55 + 20 (Category 1)
    - ▶ Crossing at Midway Road (west side) (Category 1)
    - ▶ Crossing at Midway Road (east side) (Category 1)
    - ▶ Power Pole at stations 61 + 70 and 62 + 40 (Category 1)
  - Sheet 2 of 2
    - ▶ Power pole at stations 63+10, 63+60, and 64+80 (Category 1)
    - ▶ Crossing at station 86 + 10 (Category 1)

- *TxU Gas Conflicts:*  
Sheet 1 of 2
  - ▶ Crossing at Surveyor Boulevard (west side) at proposed box culvert (Category 2)
  - ▶ Crossing at Midway Road (west side) (Category 2)
  
- *SBC Conflicts:*  
Sheet 1 of 2
  - ▶ Crossing at Surveyor Boulevard (west side) at proposed box culvert (Category 2)
  - ▶ Crossing at Surveyor Boulevard (east side) at proposed box culvert (Category 2)
  - ▶ Parallel conflict station 51 + 00 to west side of Midway Road (Category 1)
  - ▶ Crossing at Midway Road (west side) (Category 2)
  - ▶ Crossing at Midway Road (east side) (Category 2)
  
- *MCI*  
Sheet 2 of 2
  - ▶ Parallel conflict station 76 + 60 to 85 + 80 (Category 2)
  
- *Qwest*  
Sheet 2 of 2
  - ▶ Parallel conflict station 76 + 60 to 85 + 80 (Category 2)

NO.	DATE	REVISION	APPROV.
1			
2			
3			

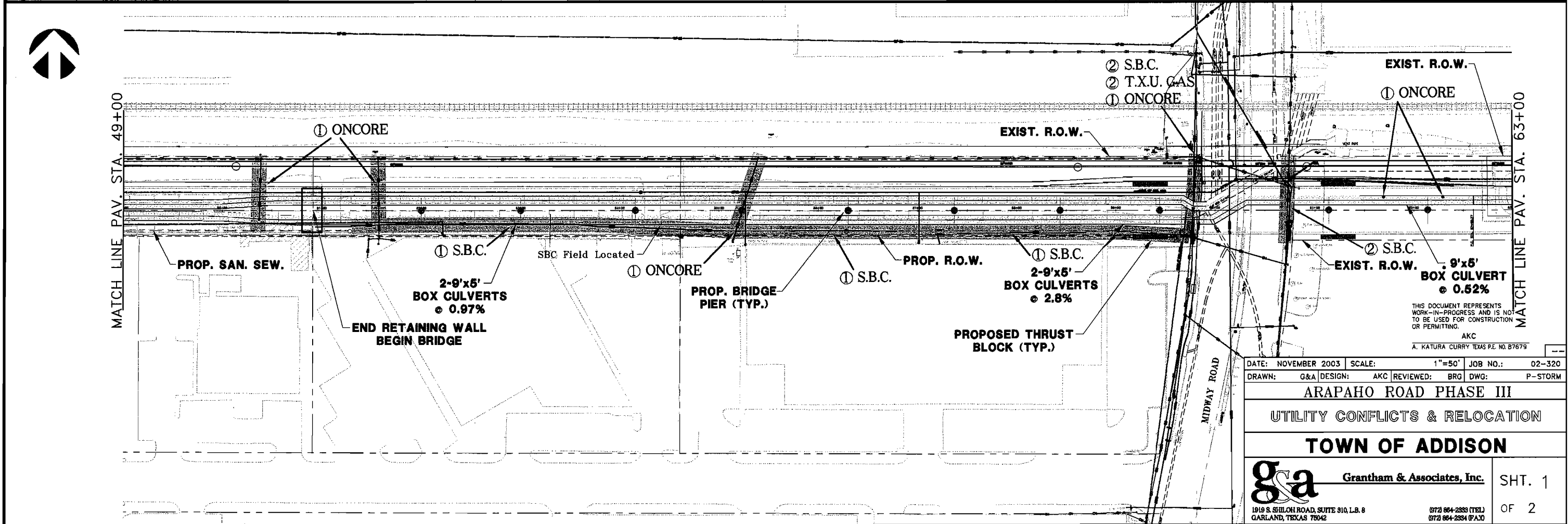
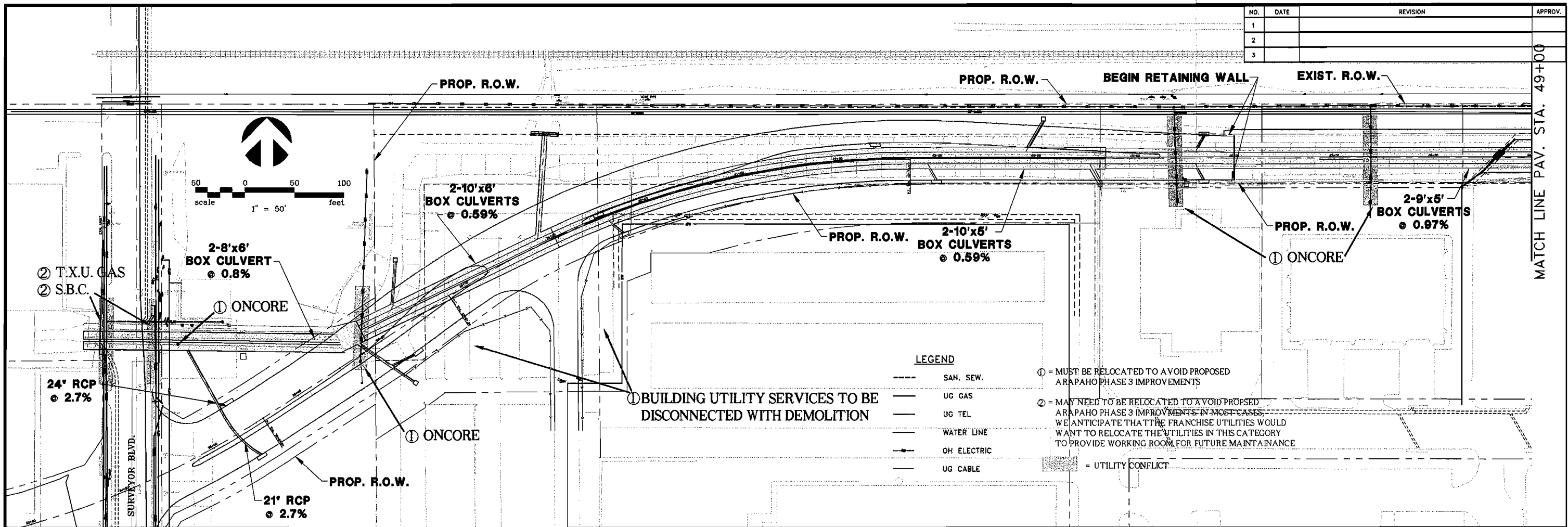

DATE: NOVEMBER 2003 SCALE: 1"=50' JOB NO.: 02-320  
 DRAWN: G&A DESIGN: AKC REVIEWED: BRG DWG: P-STORM

**ARAPAHO ROAD PHASE III**  
**UTILITY CONFLICTS & RELOCATION**  
**TOWN OF ADDISON**

**g&a** Grantham & Associates, Inc. SHT. 1  
 1919 S. SHILOH ROAD, SUITE 310, L.B. 8 GARLAND, TEXAS 75042 972 864-2333 (TEL) 972 864-2334 (FAX) OF 2

NO.	DATE	REVISION	APPROV.
1			
2			
3			

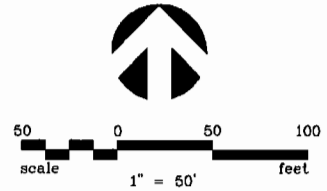

- LEGEND**
- SAN. SEW.
  - UG GAS
  - UG TEL
  - WATER LINE
  - OH ELECTRIC
  - UG CABLE
- ① = MUST BE RELOCATED TO AVOID PROPOSED ARAPAHO PHASE 3 IMPROVEMENTS
  - ② = MAY NEED TO BE RELOCATED TO AVOID PROPOSED ARAPAHO PHASE 3 IMPROVEMENTS. IN MOST CASES, WE ANTICIPATE THAT THE FRANCHISE UTILITIES WOULD WANT TO RELOCATE THE UTILITIES IN THIS CATEGORY TO PROVIDE WORKING ROOM FOR FUTURE MAINTAINANCE
  - [Hatched Box] = UTILITY CONFLICT

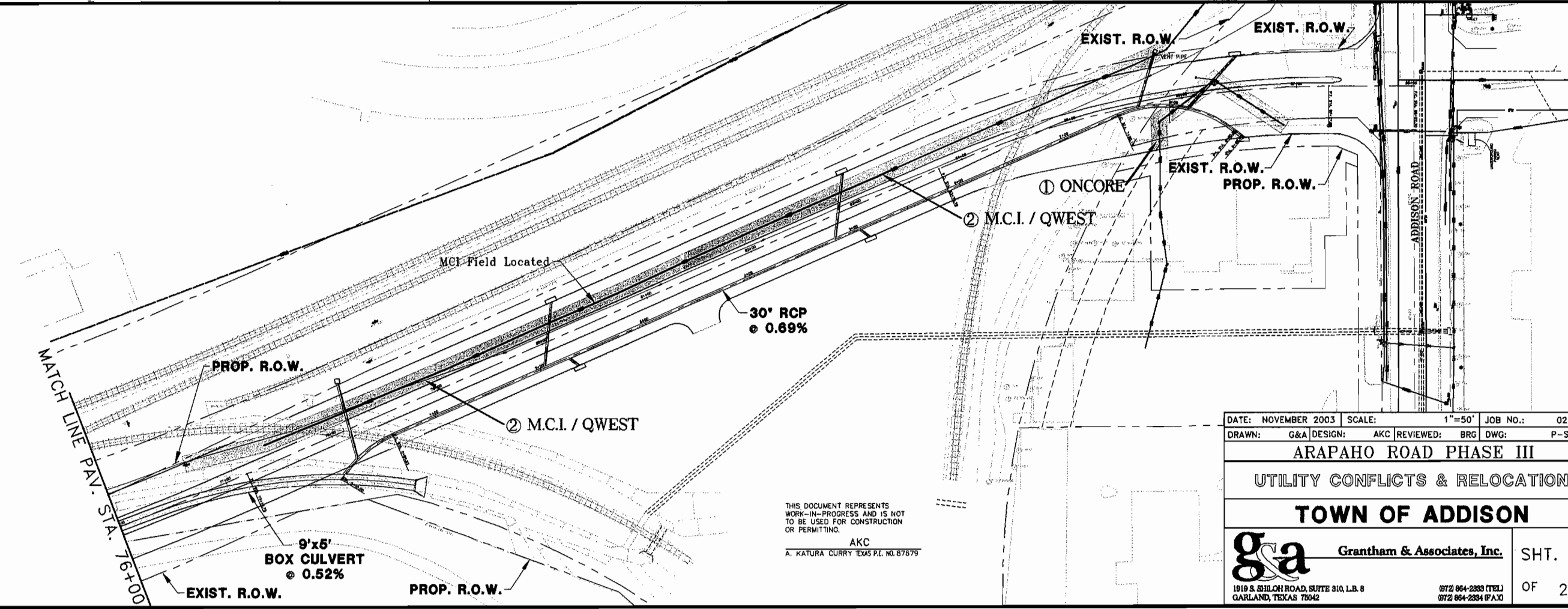
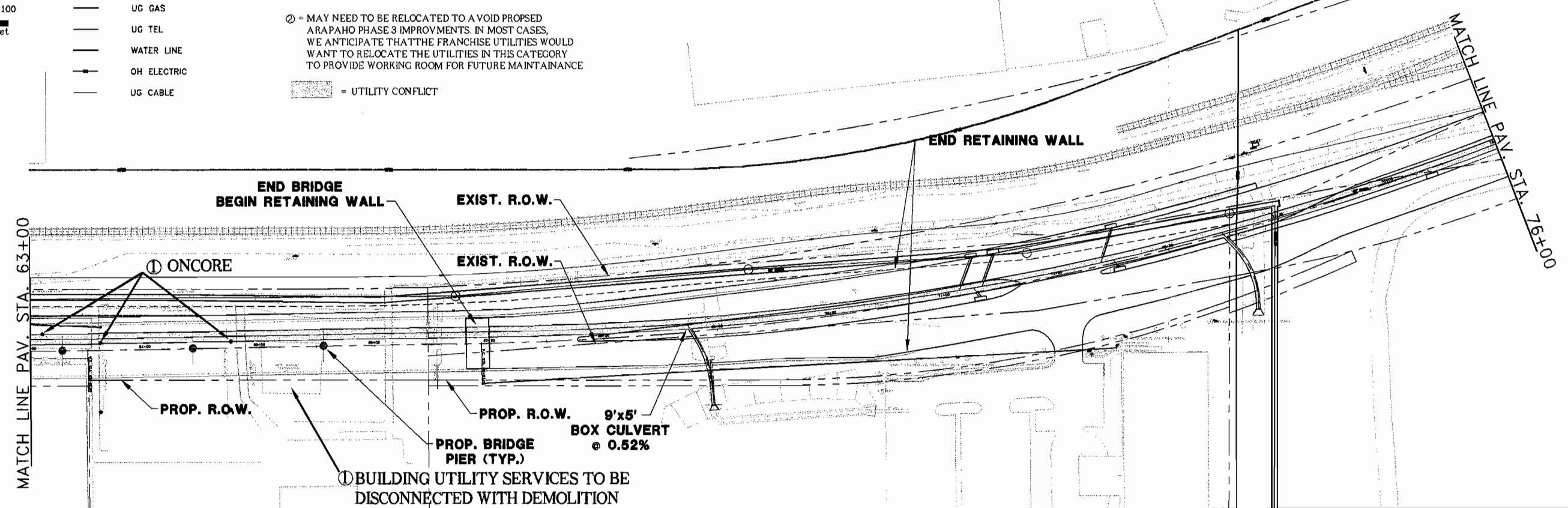

THIS DOCUMENT REPRESENTS WORK-IN-PROGRESS AND IS NOT TO BE USED FOR CONSTRUCTION OR PERMITTING.

AKC  
A. KATURA CURRY TEXAS P.L. NO. 876795

DATE: NOVEMBER 2003	SCALE: 1"=50'	JOB NO.: 02-320
DRAWN: G&A	DESIGN: AKC	REVIEWED: BRG
		DWG: P-STORM

**ARAPAHO ROAD PHASE III**

**UTILITY CONFLICTS & RELOCATION**

**TOWN OF ADDISON**



**Grantham & Associates, Inc.**  
1919 S. SHILOH ROAD, SUITE 310, L.B. 8 GARLAND, TEXAS 75042

(972) 864-2383 (TEL)  
(972) 864-2394 (FAX)

SHT. 2  
OF 2

05/09/2003 09:22 9728542334

JOHN

PAGE 03/03

**Grantham & Associates, Inc.****MEETING NOTICE**

1919 S. Shiloh Rd., Suite 310, LB 8, Garland, TX 75042

**Date:** May 5, 2003 **G&A No. 320**

**To:** All Utility Companies Concerned

**From:** Matt Kirk

**Re:** Arapaho Road Phase III Utility Coordination Meeting

---

To All Concerned,

A utility coordination meeting will be held at 10:00 a.m., May 13th, in the Conference Room of the HNTB office located at 5910 West Plano Parkway, Suite 200, Plano (see attached map).

It is requested that a representative of all companies involved in this project attend. Please bring information concerning the location of all existing utilities, if this information has not been previously provided. Detailed maps of the project will be distributed by Grantham & Associates, Inc.

For questions or concerns, please contact Matt Kirk, Grantham & Associates, Inc. at 972-864-2333.

05/09/2003 09:22 9728542334

JOHN

PAGE 02/03

## Arapaho Road Phase 3 Utility Coordination Kick-Off Meeting

**Meeting Location:** HNTB Training Room  
May 13, 2003, 10 am

**Purpose:** To identify project design elements, introduce project personnel, and begin identifying and resolving conflicts between design elements and utility locations.

### Meeting Agenda

- I. Introduction: Jerry Holder, P.E.
  - i Introduction of Design Team
  - ii Overview of Project
- II. Message from the Town: Mike Murphy, P.E.
- III. Utility Coordination Issues: Katura Curry, P.E.
  - i Distribute Project Exhibit
  - ii Review Exhibit
  - iii Identify Known Conflicts
  - iv Review Project Design / Construction Schedule
- IV. Question / Answer
- V. Adjourn

### Project Design Team:

Mike Murphy, P.E.	City Engineer	Town of Addison
Steve Chutchian, P.E.	Assistant City Engineer	Town of Addison
Jim Piccoe, P.E.	Public Works Director	Town of Addison
Jerry Holder, P.E.	Project Manager	HNTB (Roadway)
Elizabeth Metting, P.E.	Project Manger	HNTB (Roadway)
Jenny Nicewander, P.E.	Project Engineer	HNTB (Roadway)
Bruce Grantham, P.E.	Project Manger	Grantham & Associates (Utilities)
Katura Curry, P.E.	Project Engineer	Grantham & Associates (Utilities)
Cliff Hall, P.E.	Project Manager	URS (Bridge)



05/09/2003 09:22 9728642334

JOHN

PAGE 01/03

---

---

**Facsimile Transmittal**

---

---

Date: 5/9/03From: **Grantham & Associates, Inc.**Fax To: STEVE CHUTCHIAN

1919 S. Shiloh Rd.

Suite 310, L.B. 8

Of: TOWN OF ADDISON

Garland, Texas 75042

Tel. (972) 864-2333

Fax# (972) 450-2837

Fax (972) 864-2334

Email: [Info@gra-ce.net](mailto:Info@gra-ce.net)Ref: ARAPAHO RD PH 3# of Pages (including this sheet): 3Fax From: KATURA CURRY**Comments:**

Steve,

Please review the Agenda for the upcoming Utility Coordination meeting. We have Mike Murphy doing comments for the Town. Please confirm this or let me know who will be doing these.

Thanks,  
Katura

## Jenny Nicewander

---

**From:** Jenny Nicewander  
**Sent:** Monday, November 01, 2004 1:43 PM  
**To:** 'paulmayfield@basshays.com'  
**Subject:** RE: logos for approval

They look good to me and have the Town's approval.

-----Original Message-----

**From:** Paul Mayfield [mailto:paulmayfield@basshays.com]  
**Sent:** Monday, November 01, 2004 1:09 PM  
**To:** Jenny Nicewander  
**Subject:** logos for approval

hi jenny

the bh400-24 manhole lid storm sewer (v1121) should be no problem it is like your sanitary sewer lid  
check the bh184l lid (102lock) for approval let me know when you accept this or any changes and we will proceed with the casting changes and get this done asap.

thank you

paul mayfield  
BASS HAYS FNDRY INC.  
238 S. BAGDAD  
GRAND PRAIRIE TX. 75050  
972-263-1360  
PAULMAYFIELD@BASSHAYS.COM

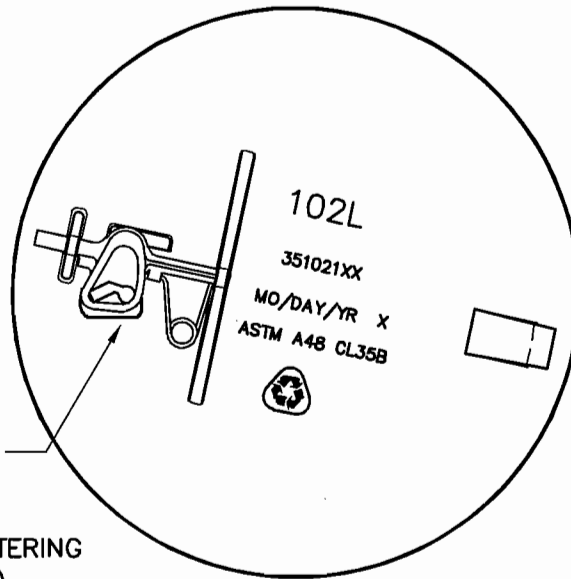
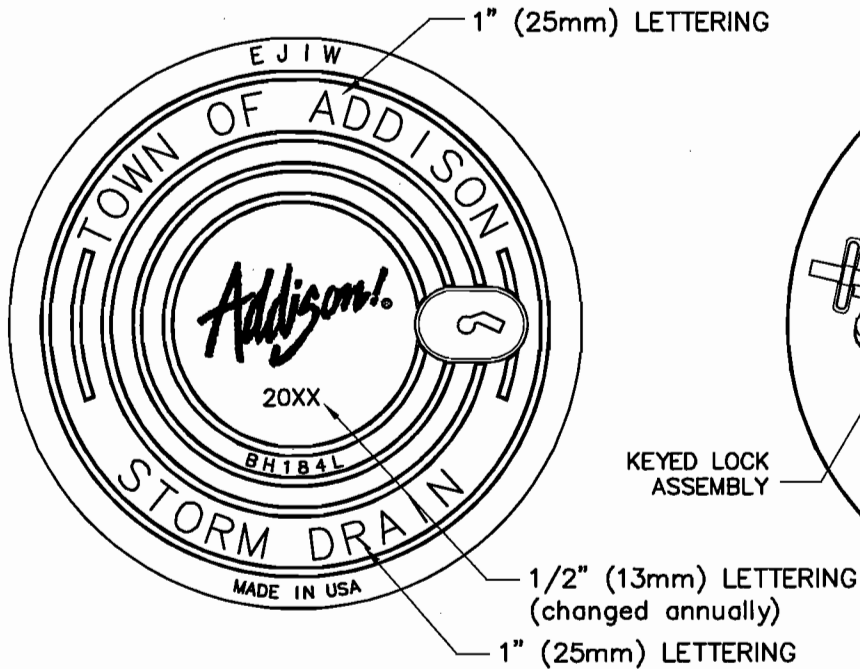

**BOTTOM VIEW**

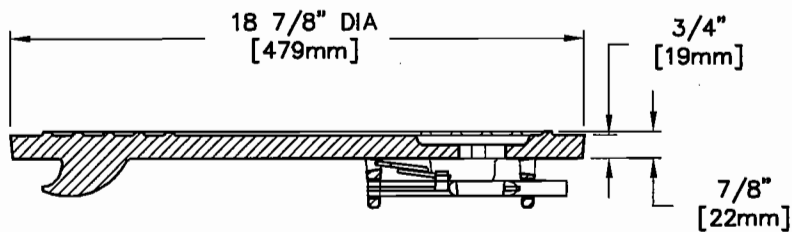

**COVER SECTION**

<b>EAST JORDAN IRON WORKS, INC.</b>	
P.O. BOX 439 EAST JORDAN, MI. 49727 1-800-874-4100 FAX 231-536-4458	
DRAWN SMH	DATE 10/29/04
APPROVED	DATE
<b>LOCK COVER ASSEMBLY</b>	
PRODUCT NO. <b>NCR04-2138C</b>	
CATALOG NO. <b>102 LOCK</b>	
REF. SALES DRAWING 35102108	
EST. WT. COVER: 50 LBS 25kg	
OPEN AREA N/A	
MAT'L SPEC. COVER - CAST IRON ASTM A48 CL35B	
LOAD RATING <b>LIGHT DUTY</b>	

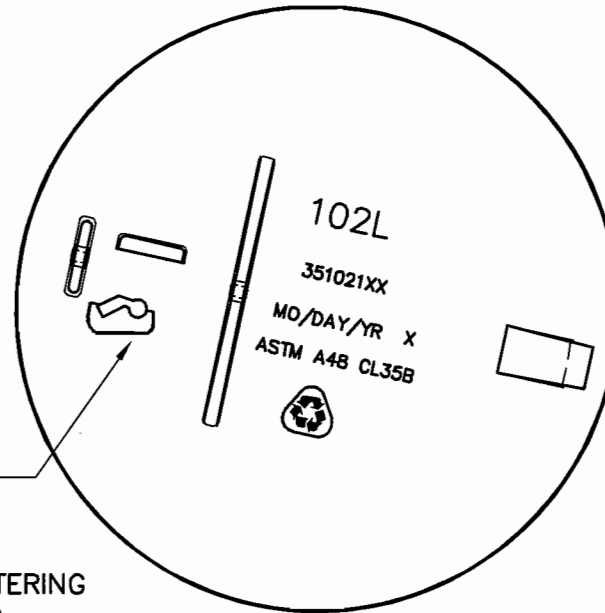
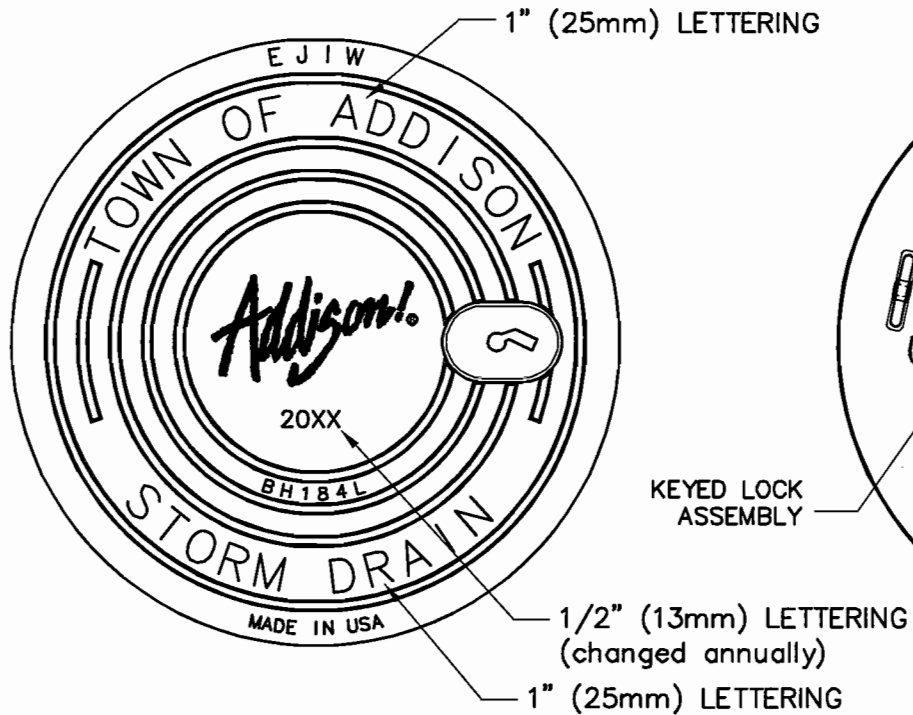

**BOTTOM VIEW**

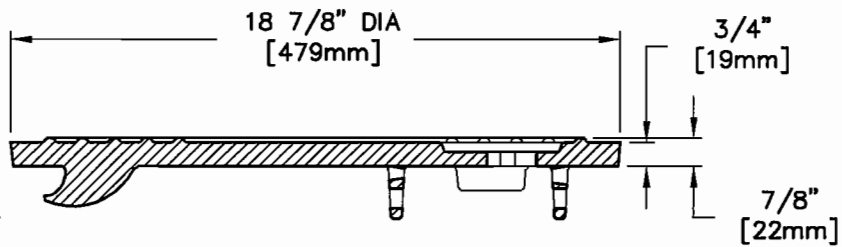

**COVER SECTION**

**EAST JORDAN  
IRON WORKS, INC.**

P.O. BOX 439  
EAST JORDAN, MI. 49727  
1-800-874-4100  
FAX 231-536-4458

DRAWN SMH	DATE 10/29/04
APPROVED	DATE

**102 L COVER**

PRODUCT NO.

**NCR04-2138B**

CATALOG NO.

**102 L**

REF. PRODUCT DRAWING  
35102108

EST. WT.

COVER: 50 LBS 25kg

OPEN AREA  
N/A

MAT'L SPEC.  
COVER - CAST IRON  
ASTM A48 CL35B

LOAD RATING

**LIGHT DUTY**



Matt Kirk

---

**Grantham & Associates, Inc.**  
Civil Engineers      Serving with Integrity

1919 S. Shiloh Road  
Suite 310, L.B. 8  
Garland, Texas 75042

Tel. (972) 864-2333  
Fax (972) 864-2334  
[www.gra-ce.net](http://www.gra-ce.net)

---

[mkirk@gra-ce.net](mailto:mkirk@gra-ce.net)



# Arapaho Road Phase 3 Utility Coordination Kick-Off Meeting

**Meeting Location:** HNTB Training Room

**Meeting Time:** May 13, 2003, 10 am

**Purpose:** To identify project design elements, introduce project personnel, and begin identifying and resolving conflicts between design elements and utility locations.

## Meeting Agenda

- I. Introduction: HNTB
  - i Introduction of Design Team
  - ii Overview of Project
  
- II. Message from the Town: The Town of Addison
  
- III. Utility Coordination Issues: Grantham & Associates
  - i Project Exhibit
  - ii Project Elements
  - iii Known Conflicts
  - iv Project Design / Construction Schedule
  - v Regularly Scheduled Coordination Meetings
  
- IV. Question / Answer
  
- V. Adjourn

### Project Design Team:

Mike Murphy, P.E.	City Engineer	Town of Addison
Steve Chutchian, P.E.	Assistant City Engineer	Town of Addison
Jim Pierce, P.E.	Public Works Director	Town of Addison
Luke Jalbert	Project Manager	Town of Addison
Jerry Holder, P.E.	Project Manager	HNTB (Roadway)
Elizabeth Metting, P.E.	Project Manager	HNTB (Roadway)
Jenny Nicewander, P.E.	Project Engineer	HNTB (Roadway)
Rob Kouba, P.E.	Project Engineer	HNTB (Roadway)
Bruce Grantham, P.E.	Project Manager	Grantham & Associates (Utilities)
Katura Curry, P.E.	Project Engineer	Grantham & Associates (Utilities)
Matt Kirk	Utility Coordinator	Grantham & Associates (Utilities)
Cliff Hall, P.E.	Project Manager	URS (Bridge)
Jack Hatchell	Project Manager	Jack Hatchell & Associates (Traffic Signalization)

**Arapaho Road Phase 3  
Utility Coordination Kick-Off Meeting**

**Utility Information Sheet**

**Name** \_\_\_\_\_

**Company** \_\_\_\_\_

**Address** \_\_\_\_\_

\_\_\_\_\_

**Phone** \_\_\_\_\_ **Fax** \_\_\_\_\_

**E-mail** \_\_\_\_\_

**Will you be the primary contact for this project?** \_\_\_\_\_

**If No, who should we contact:** \_\_\_\_\_

\_\_\_\_\_



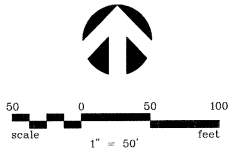

MATCH LINE STA. 64+00

MATCH LINE STA. 79+00

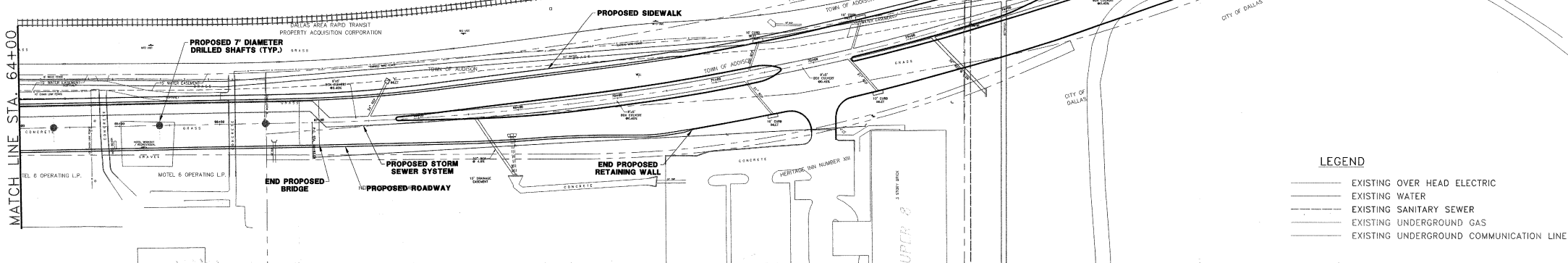

- LEGEND**
- EXISTING OVER HEAD ELECTRIC
  - EXISTING WATER
  - - - EXISTING SANITARY SEWER
  - EXISTING UNDERGROUND GAS
  - EXISTING UNDERGROUND COMMUNICATION LINE

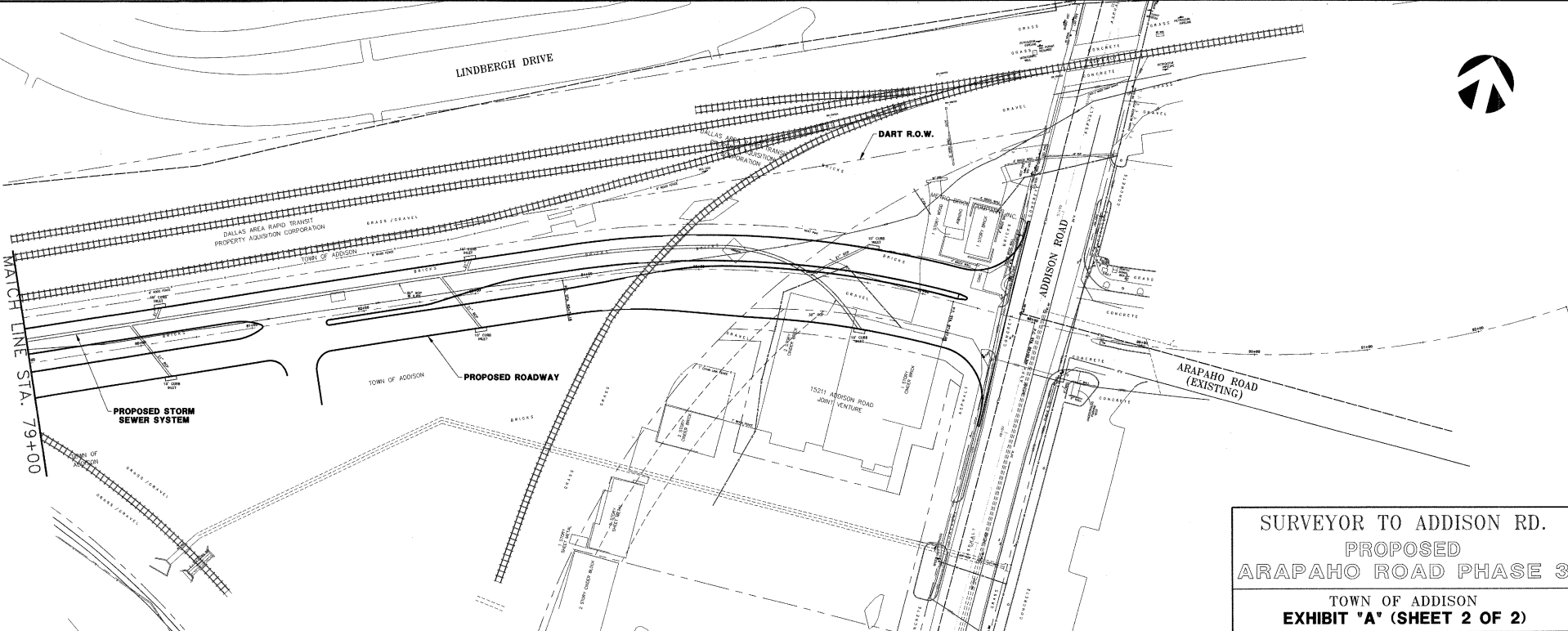

SURVEYOR TO ADDISON RD.  
 PROPOSED  
**ARAPAHO ROAD PHASE 3**  
 TOWN OF ADDISON  
**EXHIBIT 'A' (SHEET 2 OF 2)**



50 0 50 100  
 scale 1" = 50' feet

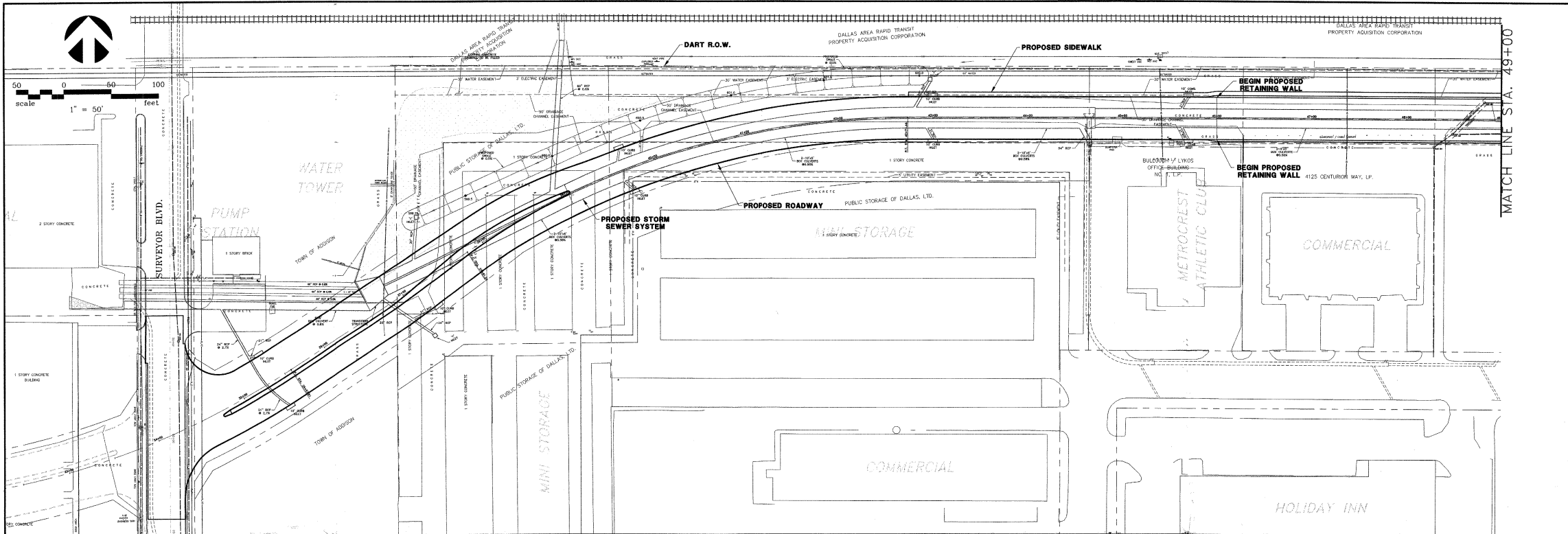

MATCH LINE STA. 49+00

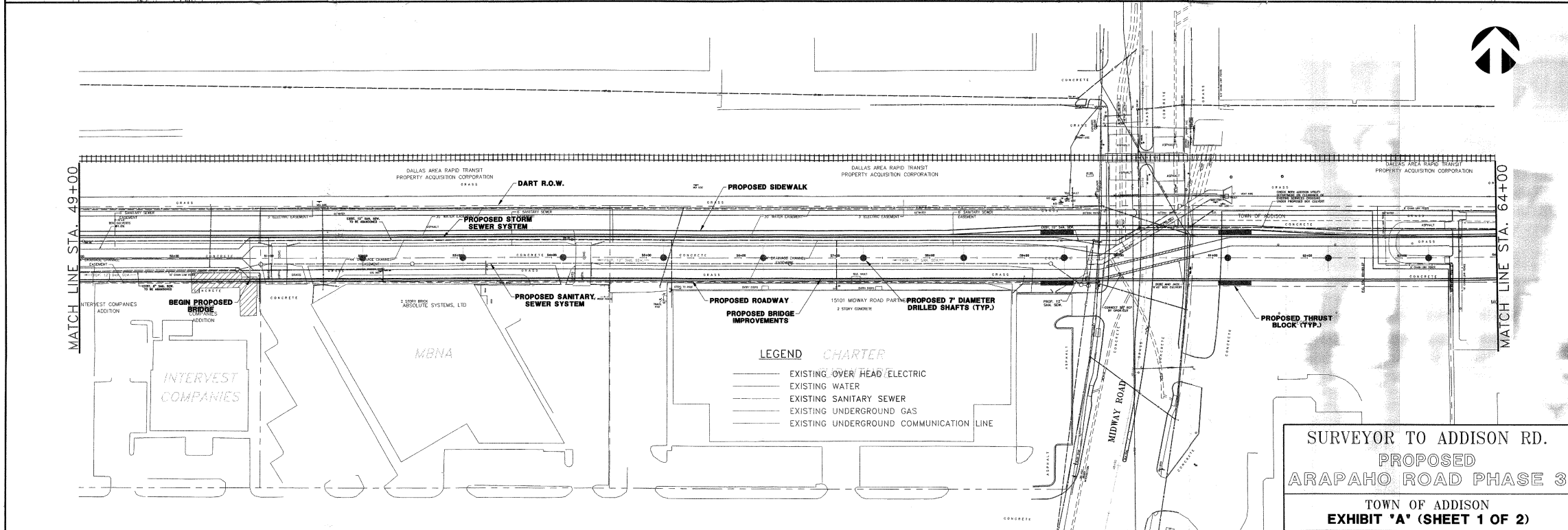

MATCH LINE STA. 64+00

- LEGEND CHARTER**
- EXISTING OVER HEAD/ELECTRIC
  - EXISTING WATER
  - EXISTING SANITARY SEWER
  - EXISTING UNDERGROUND GAS
  - EXISTING UNDERGROUND COMMUNICATION LINE

**SURVEYOR TO ADDISON RD.  
 PROPOSED  
 ARAPAHO ROAD PHASE 3  
 TOWN OF ADDISON  
 EXHIBIT 'A' (SHEET 1 OF 2)**