

# SUBMITTAL

## VILLAGE ON THE PARKWAY

Addison, TX

### SUBMITTAL REVIEW

- |  |  |
|--|--|
| <input type="checkbox"/> NO EXCEPTIONS TAKEN               | <input type="checkbox"/> REVISE AND RESUBMIT   |
| <input checked="" type="checkbox"/> MAKE CORRECTIONS NOTED | <input type="checkbox"/> SUBMIT SPECIFIED ITEM |

CHECKING IS ONLY FOR GENERAL CONFORMANCE WITH THE DESIGN CONCEPT OF THE PROJECT AND GENERAL COMPLIANCE WITH THE INFORMATION IN THE CONTRACT DOCUMENTS. ANY ACTION SHOWN ABOVE, IS SUBJECT TO THE REQUIREMENTS OF THE PLANS AND SPECIFICATIONS. CONTRACTOR IS RESPONSIBLE FOR: DIMENSIONS WHICH SHALL BE FABRICATED AND CORRELATED AT THE JOB SITE; FABRICATION PROCESSES AND TECHNIQUES OF CONSTRUCTION; COORDINATION OF HIS WORK WITH THAT OF ALL OTHER TRADES; AND THE SATISFACTORY PERFORMANCE OF HIS WORK.

TOWN OF ADDISON  
P.O. BOX 9010 ADDISON, TX 75001

BY REW DATE 10/24/13



**PCI Construction**  
**P.O. Box 2967**  
**McKinney, TX 75070**  
**Phone: (972)562-2762**  
**Fax: (972)562-2954**



# TABLE OF CONTENTS



- Water
  - Meter Vault

# WATER



# METER VAULT



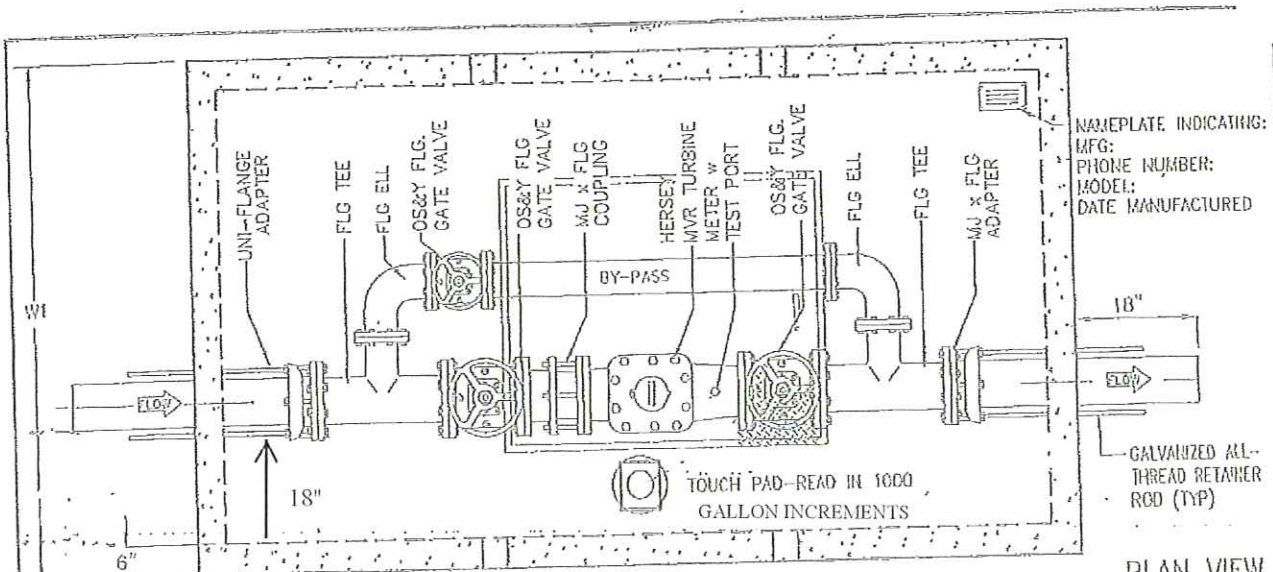

NAMEPLATE INDICATING:  
 MFG:  
 PHONE NUMBER:  
 MODEL:  
 DATE MANUFACTURED

PLAN VIEW

SIZE	BY PASS	LI	WI	H1	WEIGHT LBS
4"	4"	8'-8"	5'-0"	6'-0"	14,000
6"	6"	11'-0"	6'-0"	6'-0"	22,500

IF METER HAS NO INTEGRAL TEST PORT, PROVIDE X" BY 2" T OR SADDLE, 2" STAINLESS STEEL BALL VALVE WITH SS HANDLE, AND 2" BRASS PLUG.

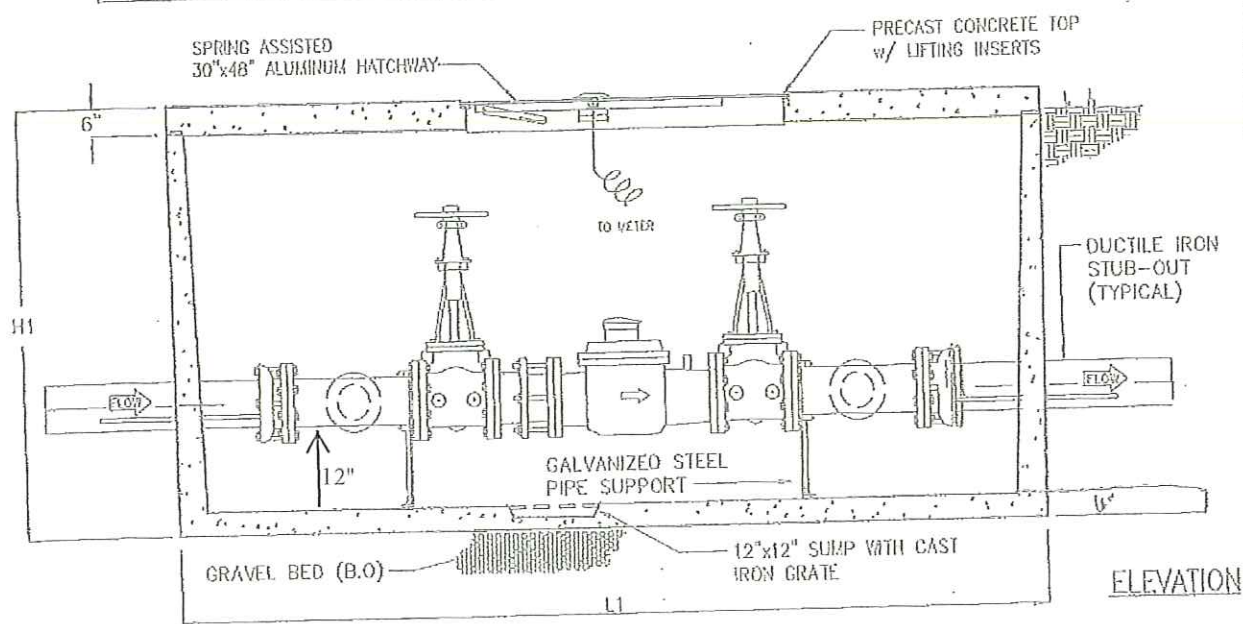

ELEVATION

- NOTES:
1. ALL CONCRETE SHALL BE CLASS 1 CONCRETE WITH DESIGN STRENGTH OF 4500 PSI AT 28 DAYS. UNITS ARE OF MONOLITHIC CONSTRUCTION AT FLOOR AND FIRST STAGE OF WALL WITH SECTIONAL RISER TO REQUIRED DEPTH.
  2. ALL REINFORCEMENT SHALL BE GRADE 60 REINFORCED STEEL REBAR CONFORMING TO ASTM A615 ON REQUIRED CENTERS OR EQUAL.
  3. ALL HATCHWAYS SHALL BE 1/2" ALUMINUM DIAMOND PLATE COVER, WITH 1/2" EXTRUDED ALUMINUM FRAME. HATCH TO BE FURNISHED WITH 316 STAINLESS STEEL SNAP LOCK AND HINGES.
  4. THE METER ASSEMBLY SHALL BE FACTORY ASSEMBLED IN VAULT AND HYDROSTATICALLY TESTED PRIOR TO DELIVERY. PIPE, VALVES AND FITTINGS OF THE ASSEMBLY SHALL BE IN ACCORDANCE WITH THE TOWN OF ADDISON WATER SYSTEM REQUIREMENTS.

*Addison!*

TURBINE WATER METER ASSEMBLY

Final **DRAFT**  
 10/24/13

STANDARD CONSTRUCTION DETAILS WATER

DATE: AUGUST, 2010	REV DATE:	SHEET: SD-W22
-----------------------	-----------	------------------

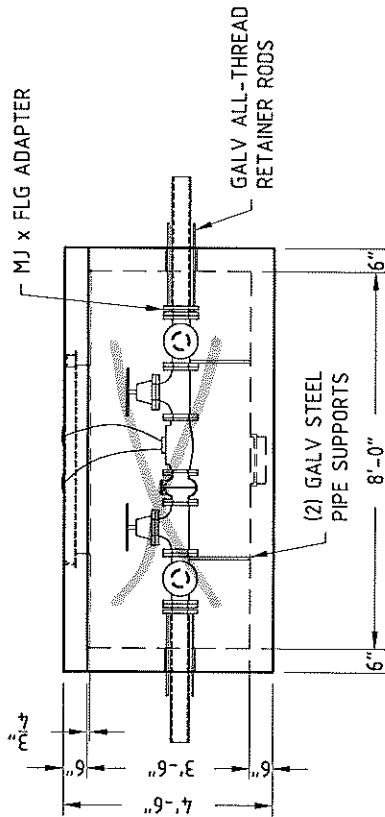

**FRONT VIEW**

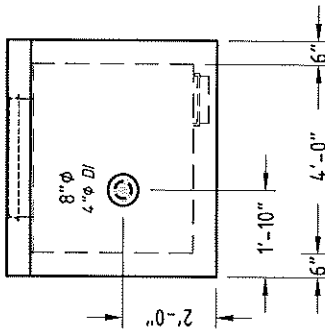

**RIGHT VIEW**

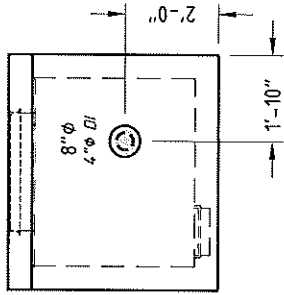

**LEFT VIEW**

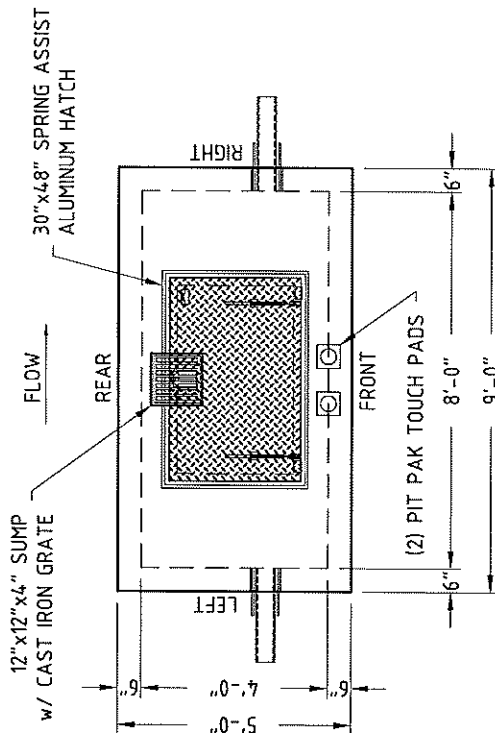

**PLAN VIEW**

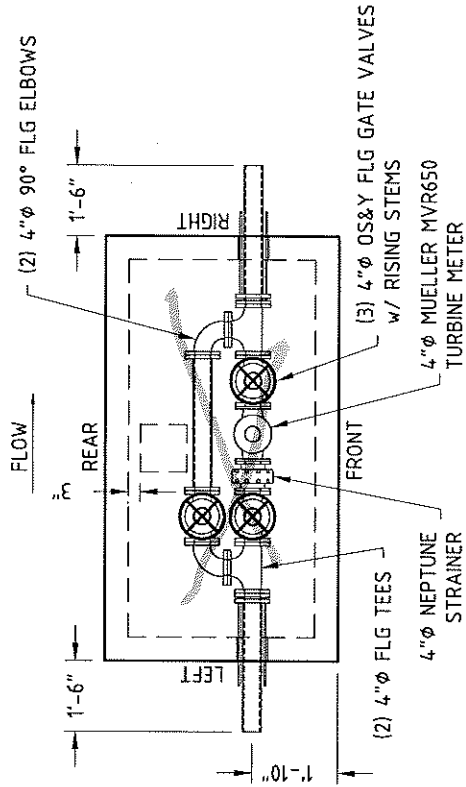

**PLAN VIEW - PIPING**

<b>Hanson</b> HEIDELBERGCEMENTGroup		REVISIONS A CHANGED TO TURBINE METER - TUG 10/24/13 B - C - D -		DRAWN BY: TUG CHECKED: SOLD BY: - SCALE: 1/4" = 1' ORDER# -	SLABTOP BASE 3,325# 10,350#	4" Ø TURBINE WATER METER VAULT 4'-0" x 8'-0" PCI VILLAGES ON THE PARKWAY	TOTALS: 13,675# DATE: 8/30/13 PAGE 1 OF 1
		DATE: 8/30/13		TOTALS: 13,675#	DATE: 8/30/13	PAGE 1 OF 1	

# Model MVR

**Mueller SYSTEMS**

## Magnetic Drive Vertical Turbine Meters

Sizes 3/4"x1/2", 3/4", 3/4"x1", 1", 1-1/2", 2", 3", 4" and 6"

### Features

**APPLICATIONS:** Measurement of water for residential, commercial, industrial and residential fire applications, where sensitivity to low flow is also important. Hersey® MVR meters are among the most sensitive vertical turbine meters available and may be used in place of compound meters in some applications. The compact design and integral strainer (separate external strainer is not needed) of Model MVR meters facilitate installation in tight spaces. They are ideal where flexibility is needed to meet wider flow ranges, where water temperatures are elevated between 80°F and 130°F, or where sand particles or other small debris may be encountered. May be installed vertically or horizontally for greater installation flexibility.

**CONFORMANCE TO STANDARDS:** Hersey Model MVR Water Meters comply with ANSI/AWWA Standard C701 Class I. Each meter is tested to ensure compliance. EnviroBrass® II options conform to the NSF 61 Standard.

**CONSTRUCTION:** Hersey Model MVR Water Meters consist of three basic parts: maincase; rotor assembly; and a permanently sealed register. Main-cases are made of bronze for long life. Rotor assemblies are thermoplastic, which is dimensionally stable and will not corrode. Retro Thrust rotor design extends the life of the meter by dividing wear between two points: during low flow the tungsten carbide thrust bearing floats against a sapphire bearing surface; during high flow the stainless steel shaft gently contacts a second sapphire bearing. During medium flow, the rotor floats between the thrust bearings without contact. Optional test ports are available on all sizes 1-1/2" and larger. The measuring chamber is protected by an internal strainer. No external strainer is required.

**REGISTER:** Permanently sealed register has a unique seal and heat-treated glass to eliminate dirt, moisture infiltration and lens fogging. The totalizing register has a straight-reading odometer type display, a 360° test circle with center sweep hand and a low flow (leak) detector.

All Hersey Meter models have electronic meter reading systems available for increased reading efficiency (see Meter Reading Systems.)

**OPERATION:** Water flows through the integral strainer and into the vertical turbine assembly. There the direction of the water flow is directed by the hub into the rotor at the precise angle necessary for accurate measurement over the full range of flow rates. No straight pipe requirements apply before or after the meter. The turbine turns freely and rotates in direct proportion to the volume of water passing through the meter. The Model MVR turbine operates more quietly than conventional disc or piston meters.

**MAINTENANCE:** The Hersey Model MVR Water Meters are designed and manufactured to provide long service life. The register on all sizes, and meter interior and strainer on sizes 3" and larger, can be replaced without removing the meter from the line. Modular design and economical internal parts allow for inexpensive, speedy rebuilds. Optional built-in test ports make field testing easy and convenient.

**CONNECTIONS:** Available with external (N.P.S.M.) straight pipe threads (ANSI B1.20.1) on 3/4" and 1" sizes; integral two-bolt oval flanges or internal (NPT) pipe threads (ANSI B1.20.1) on 1-1/2" and 2" sizes. ANSI class 150 flanges on 3" through 6" sizes (class 125 cast iron or class 150 bronze companion flanges available on request).



MVR 30



MVR 30 with adapter



MVR 350

Model MVR

### Materials and Specifications

MODEL NUMBER	MVR 30, MVR 30A, MVR 30B, MVR 50, MVR 100, MVR 160, MVR 350, MVR 650, and MVR 1300.
SIZES	3/4"x1/2", 3/4", 3/4"x1", 1", 1-1/2", 2", 3", 4" and 6"
STANDARDS	Manufactured and tested to meet or exceed all applicable parts of ANSI/AWWA C701 Class I Standard.
SERVICE	Cold water measurement with flow in only one direction.
OPERATING FLOW RANGE	See Chart on following page
ACCURACY	See Chart on following page
PRESSURE LOSS	See Chart on following page
MAXIMUM WORKING PRESSURE	150 PSI
TEMPERATURE RANGE	33°F to 130°F water temperature Hot water up to 180° available upon request.
MEASURING ELEMENT	Rotor
REGISTER TYPE	Straight reading, permanently sealed, magnetic drive with low flow indicator. Remote reading units optional.
METER CONNECTIONS	1/2", 3/4" and 1" external (NPSM) straight pipe threads, 1-1/2 size and 2" size available with either two bolt flanged ends or internal thread (NPT) ends same nominal size as size of meter, 3" thru 6" ANSI class 150 flanges.
MATERIALS	Maincase – bronze UNSC84400; 3/4"- 1-1/2" Bottom cover – cast iron ASTM A126 CL. B enamel painted; 2" Bottom cover – bronze UNSC84400; Rotor assembly – thermoplastic; Strainer – thermoplastic std. in 3/4" thru 1-1/2"; or stainless steel (2" – 6"); Casing bolts – stainless steel ANSI B18.
OPTIONS	Meter case – EnviroBrass® II UNSC89520. Stainless steel ring strainer is available on 3/4", 1" and 1-1/2" meters. AMR Reading Systems.

### Meter Registration

Meter Size	Initial Dial*	Capacity	Initial Dial *	Capacity
3/4"	10 Gallons	10 Million	1 Cubic Foot	1 Million
1"	10 Gallons	10 Million	1 Cubic Foot	1 Million
1-1/2"	100 Gallons	100 Million	10 Cubic Feet	10 Million
2"	100 Gallons	100 Million	10 Cubic Feet	10 Million
3"	100 Gallons	100 Million	10 Cubic Feet	10 Million
4"	100 Gallons	100 Million	10 Cubic Feet	10 Million
6"	1000 Gal	1 Billion	100 Cubic Ft	100 Mill.

\* Registration equal to one full revolution of the sweep hand.

### Flow Characteristics

Meter Size	Typical Low Flow (95% Min.)	Typical Operating Range (100% ± 2%)	Maximum Continuous Operation	Maximum Intermittent Flow
3/4"	1/2 GPM	1 to 30 GPM	25 GPM	35 GPM
1"	3/4 GPM	1-1/2 to 50 GPM	35 GPM	55 GPM
1-1/2"	1-1/2 GPM	2 to 100 GPM	70 GPM	110 GPM
2"	2 GPM	3 to 160 GPM	115 GPM	175 GPM
3"	2-1/2 GPM	4 to 350 GPM	240 GPM	390 GPM
4"	3-1/2 GPM	5 to 650 GPM	450 GPM	715 GPM
6"	5 GPM	15 to 1300 GPM	910 GPM	1430 GPM

### Dimensions and Weights

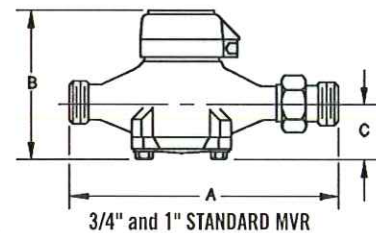

3/4" and 1" STANDARD MVR

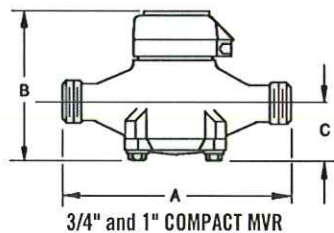

3/4" and 1" COMPACT MVR

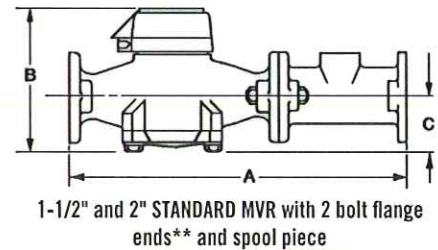

1-1/2" and 2" STANDARD MVR with 2 bolt flange ends\*\* and spool piece

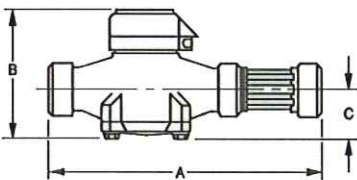

1-1/2" and 2" STANDARD MVR with Internal NPT ends

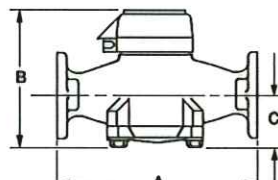

1-1/2" and 2" COMPACT MVR with integral 2 bolt flange ends\*\*

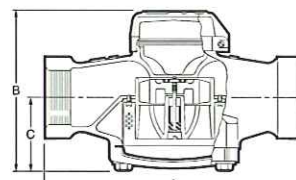

1-1/2" and 2" COMPACT MVR with Internal NPT ends

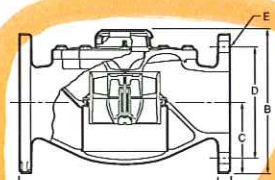

3", 4" and 6" MVR

Meter Size	3/4"x1/2"	3/4"	3/4"x1"	1"	1-1/2"	2"	1-1/2"	2"	3"	4"	6"
Ends	Threaded (screwed)						Flanged				
Model	MVR30	MVR30A	MVR30B	MVR50	MVR100	MVR160	MVR100	MVR160	MVR350	MVR650	MVR1300
Dimensions											
A	9"	9"	9"	10-3/4"	12-5/8"	15-1/4"	13"	17"	12"	14"	18"
AA*	7-1/2"	7-1/2"	7-1/2"	9"	9"	10-1/2"	9"	10"	-	-	-
B	5"	5"	5"	5-1/2"	5-3/4"	6-1/4"	5-3/4"	6-1/4"	8-7/16"	9-3/8"	12-9/16"
C	1-13/16"	1-13/16"	1-13/16"	2-3/8"	2-3/8"	3"	2-3/8"	3"	3-7/8"	4-5/8"	6"
D	N/A	N/A	N/A	N/A	N/A	N/A	4"	4-1/2"	6"	7-1/2"	9-1/2"
E	N/A	N/A	N/A	N/A	N/A	N/A	5/8"	5/8"	3/4"	3/4"	7/8"
F	N/A	N/A	N/A	N/A	N/A	N/A	11/16"	15/16"	5/8"	11/16"	13/16"
Max. width	3-3/4"	3-3/4"	3-3/4"	4-1/4"	4-3/8"	5-3/8"	5-3/8"	5-15/16"	7-7/8"	9-3/4"	12-7/8"
Net weight	6 (5*)	6 (5*)	6 (5*)	8 (7*)	11 (9*)	15 (14*)	12 (9*)	20 (14*)	38	68	140

\* Compact length

\*\* 1-1/2" and 2" Flanged meters have 2 bolt oval flange pattern.

NOTE: Meter couplings are optional and must be ordered separately. Weights are in pounds and are approximate.



# Model MVR

**Mueller** SYSTEMS

Magnetic Drive Vertical Turbine Meters

Sizes 3/4"x1/2", 3/4", 3/4"x1", 1", 1-1/2", 2", 3", 4" and 6"

Model MVR

## Performance

Head loss – 3/4" and 1"

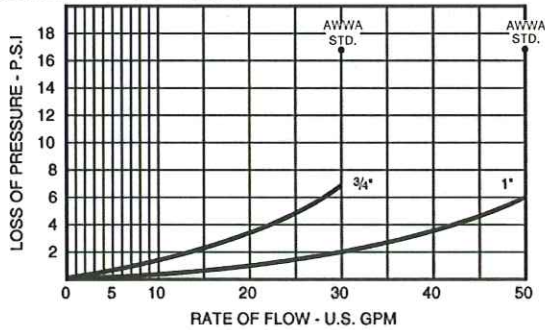

## Performance

Accuracy – 3/4" and 1"

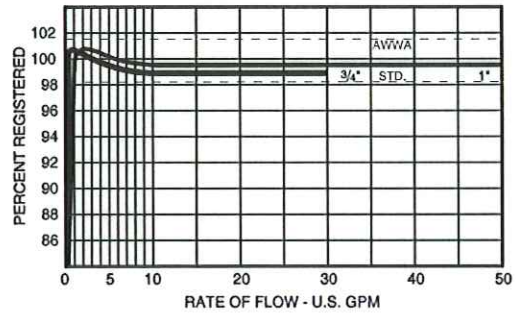

Head loss – 1-1/2" and 2"

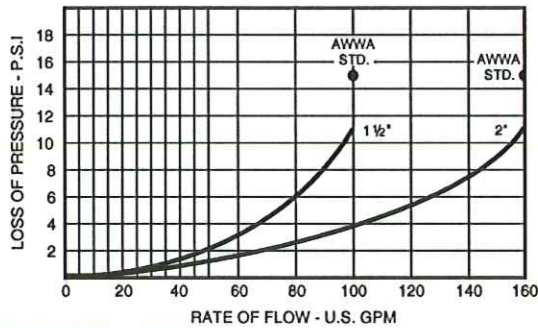

Accuracy – 1-1/2" and 2"

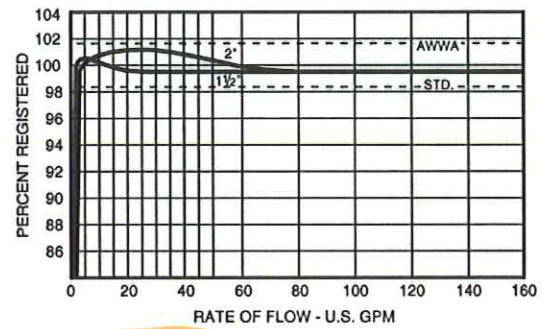

Head loss – 3" and 4"

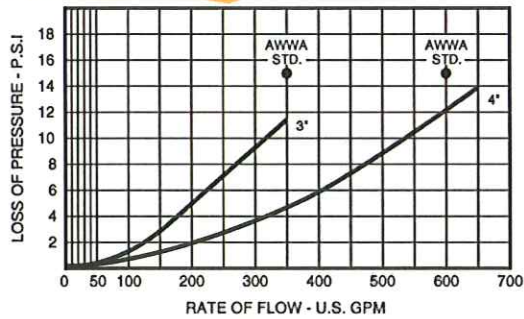

Accuracy – 3" and 4"

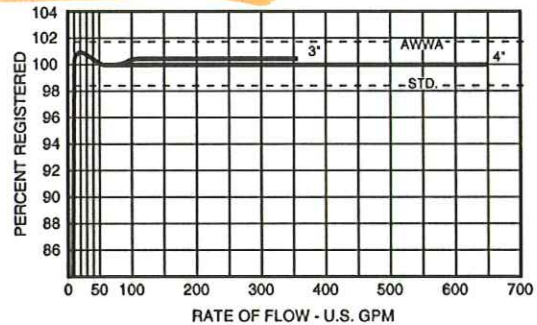

Head loss – 6"

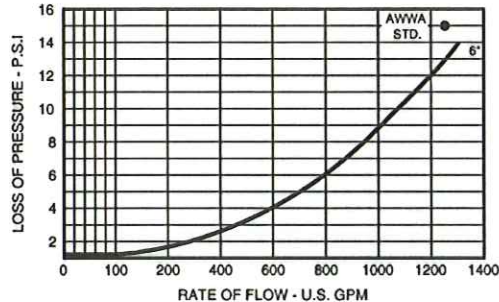

Accuracy – 6"

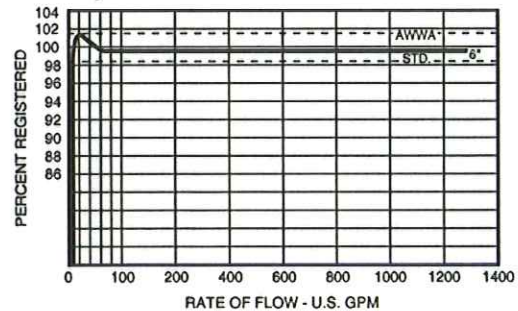

\*Performance curves are typical only and not a guarantee of performance.



Ref. No.	Description	Model MVR-30	Model MVR-50	Model MVR-100	Model MVR-160
1	Lid (Plastic)	50377	50377	50377	50377
	Lid (Bronze)	50390	50390	50390	50390
2	Black Clamp Band for Visual Register Blue Clamp Band for Translator Register	50379 B8602	50379 B8602	50379 B8602	50379 B8602
3	Lid Seal Screw	19945	19945	19945	19945
4	Lid Nut	19999	19999	19999	19999
5	Sealed Registers (Specify unit of measurement)	See pages 4.9-4.11			
6	MVR 30 Top Case (7-1/2" length): 1/2" M.I.P. Ends 3/4" M.I.P. Ends 1" M.I.P. Ends	50452 50466 (A) 50476 (B)	- - -	- - -	- - -
6	MVR 50 Top Case (9" length): 1" M.I.P. Ends 1-1/4" M.I.P. Ends	- -	50566 (C) 50576 (D)	- -	- -
6	MVR 100 Top Case (9" length): 1-1/2" F.I.P. Ends 1-1/2" Bronze 2-Bolt Flange Assembly	- -	- -	50776 (E) 50784 (F)	- -
6	MVR 160 Top Case (10-1/2" length): 2" F.I.P. Ends 2" Bronze 2-Bolt Flange Assembly (10" length)	- -	- -	- -	50866 (G) 50884 (H)
7	Rotor	50471	50571	50771	50871
8	Inlet Hub	50468	50568	50768	50867
9	Lower Bushing	50374 (2)	50574 (2)	50574 (2)	-
10	Interior Screw	98394 (4)	98394 (4)	98394 (4)	98394 (4)
11	Strainer (Plastic)	50469	50569	50769	-
12	Strainer (Metal Ring)**	50480	50580	50780	50880
13	Liner	50365	50565	50765	50865
14	Bottom (Bronze)	50363	50563	50763	50863
	Bottom (Cast Iron)	50364	50564	50764	-
15	Case Washer	AS7792 (4)	AS7792 (4)	98378 (4)	98378 (4)
16	Case Bolt	90026 (4)	90026 (4)	90073 (4)	90073 (4)
	Inlet Hub Assembly	-	-	-	50862
	Bushing Spacer	-	-	-	53114
	Bushing	-	-	-	54915 (2)
	Inlet Plug Assembly	50493	50493	50493	53105
	Sapphire Thrust Bearing (Case)	98371	98371	98371	98371
	Complete Interior	50477	50577	50777	50872
	Bearing Adhesive *	-	-	-	-
	Adapters:	95046	-	-	-
	3/4" Adapter	95014	-	-	-
	3/4" Adapter Washer	95011	95063	-	-
	1" Adapter	95064	95064	-	-
	1" Adapter Washer	-	95086	-	-
	1-1/4" Adapter	-	95007	-	-
	1-1/4" Adapter Washer	-	-	95095	-
	1-1/2" Female Adapter	-	-	-	95195
	2" Female Adapter	-	-	-	-

- A: Order 3/4" Adapter 95046 and Adapter Washer 95014 to replace standard 3/4" disc meter, 9" long.
  - B: Order 1" Adapter 95011 and Adapter Washer 95064 with Top Case 50476 to replace 3/4" disc meter, 9" long, installed with 1" pipe connections.
  - C: Order 1" Adapter 95063 and Adapter Washer 95064 with Top Case 50566 to replace standard 1" disc meter, 10-3/4" long.
  - D: Order 1-1/4" Adapter 95086 and Adapter Washer 95007 with Top Case 50576 to replace 1" disc meter, 10-3/4" long, installed with 1-1/4" pipe connection.
  - E: Order 1-1/2" Adapter 95095 with Top Case 50776 to replace 1-1/2" female end meter installed with union connections. Assemble to length of 12-5/8".
  - F: Order 1-1/2" Bronze Spool Piece 50783 and gasket 95102 with Top Case 50784 to replace standard 1-1/2" disc meter, 13" long.
  - G: Order 2" Adapter 95195 with Top Case 50866 to replace standard 2" Female End disc meter, 15-1/4" long.
  - H: Order (2) Bronze Spool piece 50883 and gasket 95122 with Top Case 50884 for 17" length 2-90229 Bolt 2-90260 Nut.
- \* Purchase locally. Use a cyanoacrylic adhesive, such as Loctite Super Bonder #30-13, Eastman #916, Permabond or Aron Alpha.

\*\*Standard on MVR 160. Optional on MVR 30, 50 100 in place of standard plastic disc strainer.  
NOTE: If more than one part is required, quantity is noted after part number (in parenthesis).

# Model MVR

Models MVR-30, MVR 50, MVR 100 and MVR 160



NA

Model MVR

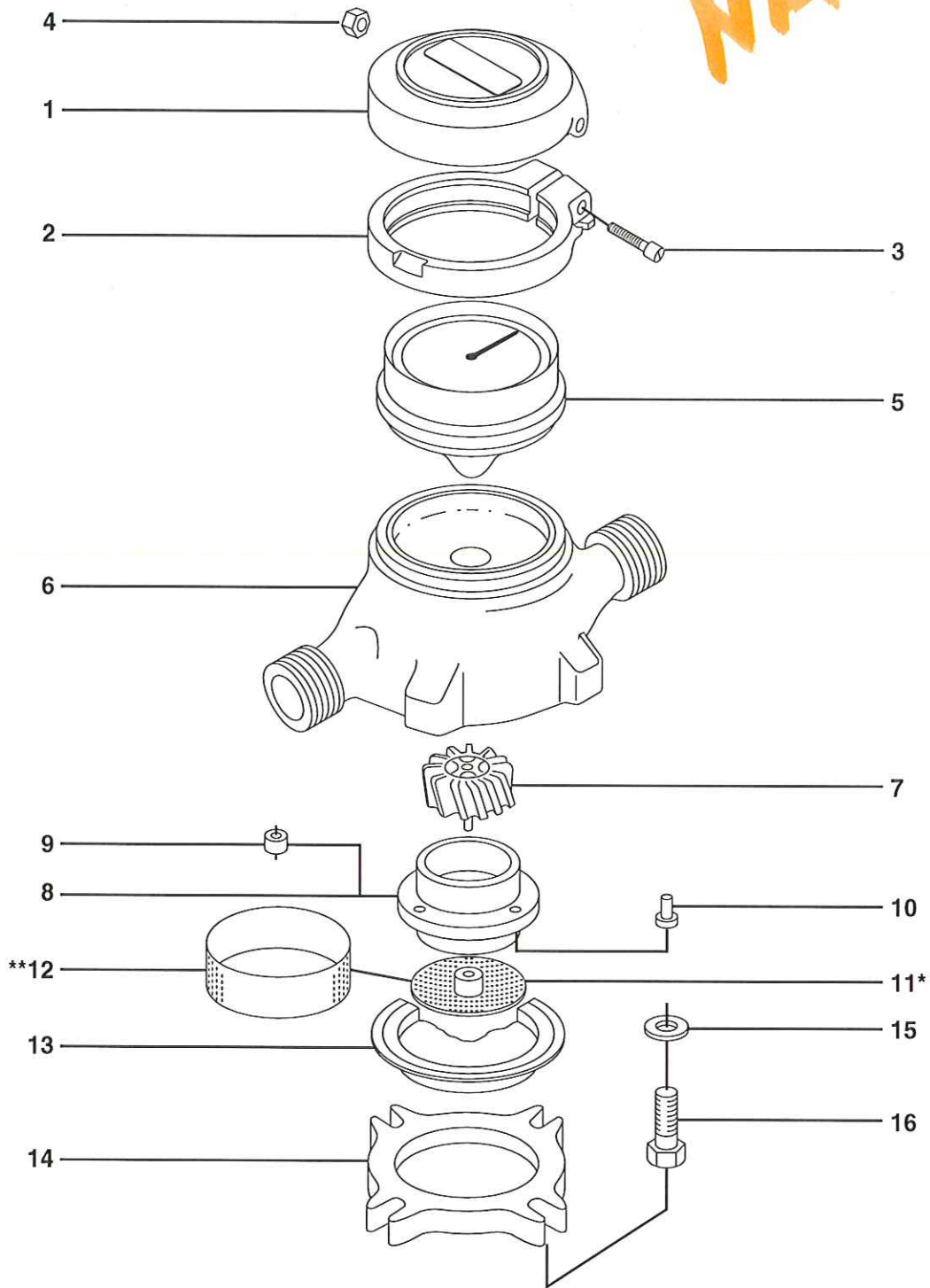

\*Disc Strainer – standard on MVR 30, 50, 100.

\*\*Ring Strainer – optional (in place of) disc strainer on MVR 30, 50 100.  
Standard on MVR 160.

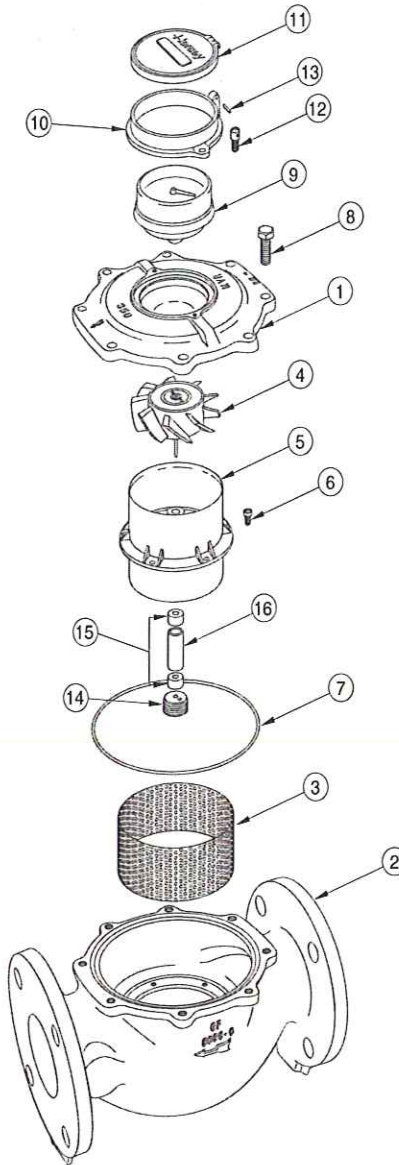

Ref. No.	Description	Model MVR-350	Model MVR-650	Model MVR-1300
1	Top Case/Thrust Bearing	50981	51181	51381
2	Bottom Case	50982	51182	51382
3	Ring Strainer	50985	51185	51383
4	Rotor Assembly	50984	51184	51384
5	Inlet Hub Assembly	50987	51187	51387
6	Inlet Hub Screws	98395 (6)	98395 (6)	98409 (12)
7	Top Case O-Ring	98361	98362	98408
8	Top Cast Screw	90073 (8)	90073 (10)	90180 (14)
9	Register	See page following pages	See page following pages	See page following pages
10	Register Box (Bronze)	50998	50998	50998
11	Lid (Bronze)	19201	19201	19201
12	Register Box Screw	51005P007 (2)	51005P007 (2)	51005P007 (2)
13	Lid Pin	AS41122	AS41122	AS41122
14	Inlet Plug/Thrust Bearing	50992	50992	-
15	Rotor Bushing	54915 (2)	56915 (2)	51392 (2)
16	Bushing Spacer	54914	51186	51391

NOTE: In order to retrofit translator registers on all 3"-6" MVR meters manufactured prior to 2003 a new top case (1) and top case o-ring (7) is required.

# Model MVR

Registers



Model MVR

MVR Model	Cubic Feet			U.S. Gallons		
	Register Part Numbers	Internal Ratio	Relation to other Registers	Register Part Numbers	Internal Ratio	Relation to other Registers
MVR-30	B79821	551.99	-4% (in relation to B79825)	B79813	738.92	-4% (in relation to B79817)
MVR-30	B79822	546.34	-3% (in relation to B79825)	B79814	731.88	-3% (in relation to B79817)
MVR-30	B79823	540.85	-2% (in relation to B79825)	B79815	723.79	-2% (in relation to B79817)
MVR-30	B79824	536.22	-1% (in relation to B79825)	B79816	715.86	-1% (in relation to B79817)
MVR-30	B79825	530.07	-	B79817	709.01	-
MVR-30	B79826	523.96	+1% (in relation to B79825)	B79818	702.61	+1% (in relation to B79817)
MVR-30	B79827	519.6	+2% (in relation to B79825)	B79819	694.85	+2% (in relation to B79817)
MVR-30	B79828	514.2	+3% (in relation to B79825)	B79820	688.55	+3% (in relation to B79817)
MVR-50	B79861	269.44	-4% (in relation to B79865)	B79851	360.58	-3% (in relation to B79854)
MVR-50	B79862	266.44	-3% (in relation to B79865)	B79852	356.41	-2% (in relation to B79854)
MVR-50	B79863	264.51	-2% (in relation to B79865)	B79853	353.17	-1% (in relation to B79854)
MVR-50	B79864	262.07	-1% (in relation to B79865)	B79854	349.42	-
MVR-50	B79865	258.83	-	B79855	345.93	+1% (in relation to B79854)
MVR-50	B79866	256.52	+1% (in relation to B79865)	B79856	342.53	+2% (in relation to B79854)
MVR-50	B79867	254	+2% (in relation to B79865)	B79857	339.04	+3% (in relation to B79854)
MVR-100	B79901	1973.95	-3% (in relation to B79904)	B79891	2664.16	-3% (in relation to B79894)
MVR-100	B79902	1951.68	-2% (in relation to B79904)	B79892	2646.98	-2% (in relation to B79894)
MVR-100	B79903	1935.27	-1% (in relation to B79904)	B79893	2605.61	-1% (in relation to B79894)
MVR-100	B79904	1912.65	-	B79894	2586.61	-
MVR-100	B79905	1901.98	+1% (in relation to B79904)	B79895	2554.55	+1% (in relation to B79894)
MVR-100	B79906	1882.77	+2% (in relation to B79904)	B79896	2526.66	+2% (in relation to B79894)
MVR-100	B79907	1862.97	+3% (in relation to B79904)	B79897	2505.78	+3% (in relation to B79894)
MVR-160	B79941	604.34	-3% (in relation to B79944)	B79931	808.31	-3% (in relation to B79934)
MVR-160	B79942	598.37	-2% (in relation to B79944)	B79932	800.5	-2% (in relation to B79934)
MVR-160	B79943	592.81	-1% (in relation to B79944)	B79933	792.41	-1% (in relation to B79934)
MVR-160	B79944	587.03	-	B79934	784.64	-
MVR-160	B79945	580.58	+1% (in relation to B79944)	B79935	775.87	+1% (in relation to B79934)
MVR-160	B79946	575.56	+2% (in relation to B79944)	B79936	768.47	+2% (in relation to B79934)
MVR-350	B79981	294.32	-2% (in relation to B79983)	B79971	394.09	-2% (in relation to B79973)
MVR-350	B79982	291.49	-1% (in relation to B79983)	B79972	389.61	-1% (in relation to B79973)
MVR-350	B79983	288.55	-	B79973	385.91	-
MVR-350	B79984	285.72	+1% (in relation to B79983)	B79974	382.06	+1% (in relation to B79973)
MVR-350	B79985	283.03	+2% (in relation to B79983)	B79975	378.6	+2% (in relation to B79973)
MVR-350	B79986	280.7	+3% (in relation to B79983)	B79976	374.11	+3% (in relation to B79973)
MVR-650	B80021	182.28	-3% (in relation to B80024)	B80013	239.51	-1% (in relation to B80014)
MVR-650	B80022	180.35	-2% (in relation to B80024)	B80014	236.41	-
MVR-650	B80023	178.86	-1% (in relation to B80024)	B80015	234.58	+1% (in relation to B80014)
MVR-650	B80024	176.9	-	B80016	232.95	+2% (in relation to B80014)
MVR-650	B80025	175.04	+1% (in relation to B80024)	B80017	230.62	+3% (in relation to B80014)
MVR-650	B80026	173.77	+2% (in relation to B80024)	B80018	228.21	+4% (in relation to B80014)
MVR-650	B80027	171.53	+3% (in relation to B80024)	-	-	-
MVR-650	B80028	170.34	+4% (in relation to B80024)	-	-	-
MVR-1300	B80067	413.35	-1% (in relation to B80068)	B80056	551.99	1% (in relation to B80057)
MVR-1300	B80068	409.41	-	B80057	546.34	-
MVR-1300	B80069	405.25	+1% (in relation to B80068)	B80058	540.85	1% (in relation to B80057)

MVR Model	Cubic Feet	US Gallons
	Standard Register	Standard Register
MVR-30	B79821	B79813
MVR-30	B79822	B79814
MVR-30	B79823	B79815
MVR-30	B79824	B79816
MVR-30	B79825	B79817
MVR-30	B79826	B79818
MVR-30	B79827	B79819
MVR-30	B79828	B79820
MVR-50	B79861	B79851
MVR-50	B79862	B79852
MVR-50	B79863	B79853
MVR-50	B79864	B79854
MVR-50	B79865	B79855
MVR-50	B79866	B79856
MVR-50	B79867	B79857
MVR-100	B79901	B79891
MVR-100	B79902	B79892
MVR-100	B79903	B79893
MVR-100	B79904	B79894
MVR-100	B79905	B79895
MVR-100	B79906	B79896
MVR-100	B79907	B79897
MVR-160	B79941	B79931
MVR-160	B79942	B79932
MVR-160	B79943	B79933
MVR-160	B79944	B79934
MVR-160	B79945	B79935
MVR-160	B79946	B79936
MVR-350	B79981	B79971
MVR-350	B79982	B79972
MVR-350	B79983	B79973
MVR-350	B79984	B79974
MVR-350	B79985	B79975
MVR-350	B79986	B79976
MVR-650	B80021	B80013
MVR-650	B80022	B80014
MVR-650	B80023	B80015
MVR-650	B80024	B80016
MVR-650	B80025	B80017
MVR-650	B80026	B80018
MVR-650	B80027	B80019
MVR-650	B80028	B80020
MVR-1300	B80067	B80053
MVR-1300	B80068	B80054
MVR-1300	B80069	B80055

# Model MVR

Translator Register Options for MVR 30 to 160

**Mueller** SYSTEMS

Model MVR

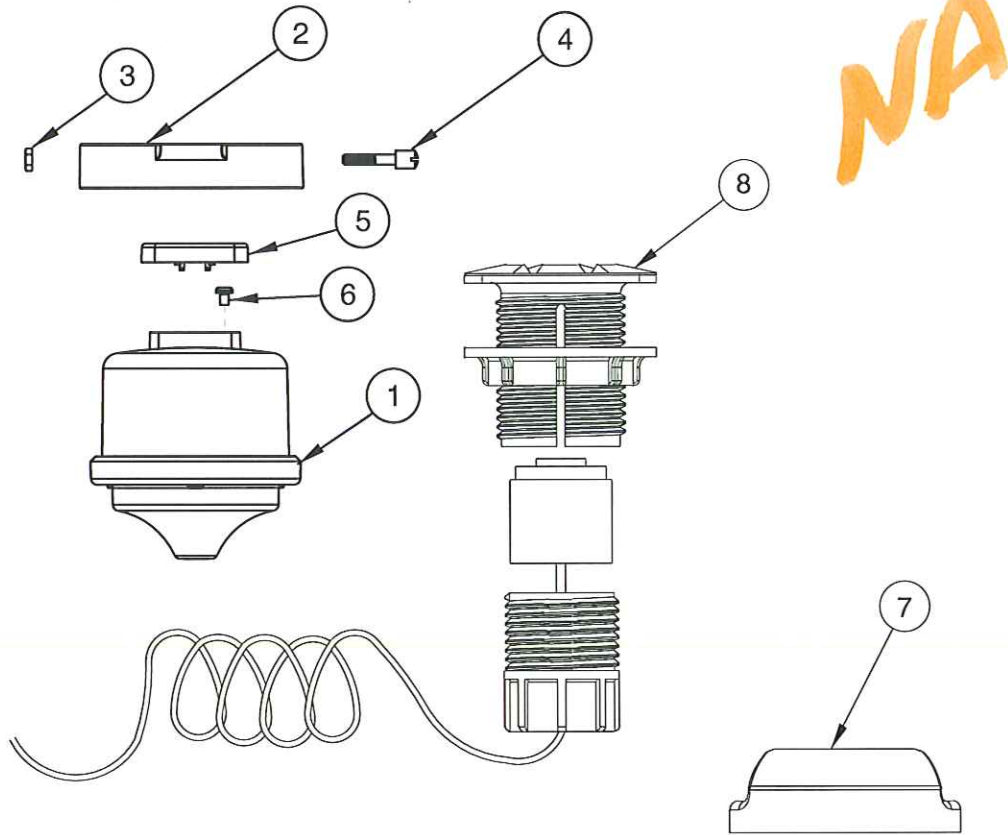

Ref	Description	MVR-30	MVR-50	MVR-100	MVR-160
1	Translator Register* Gallons Cubic Feet Specify Electronic Reading Value 4, 5, or 6 Wheel	D35231xxx D35232xxx	D35241xxx D35242xxx	D35251xxx D35252xxx	D35261xxx D35262xxx
2	Clamp Band (Plastic) Translator Only	B8602	B8602	B8602	B8602
3	Clamp Band Seal Nut	19999	19999	19999	19999
4	Clamp Band Seal Screw	19945	19945	19945	19945
5	Lens Terminal Cover	B8447	B8447	B8447	B8447
6	Terminal Lug Screw	98197 (3)	98197 (3)	98197 (3)	98197 (3)
7	Wall Pad	T1234	T1234	T1234	T1234
8	Pit Pad	T1240	T1240	T1240	T1240
9	TrueRead (not shown)	C6551G	C6551G	C6551G	C6551G
10	1,000' Spool of Wire (not shown)	AS755	AS755	AS755	AS755

\*Call Mueller Systems Customer Service for appropriate Translator Register and AMR device part number.

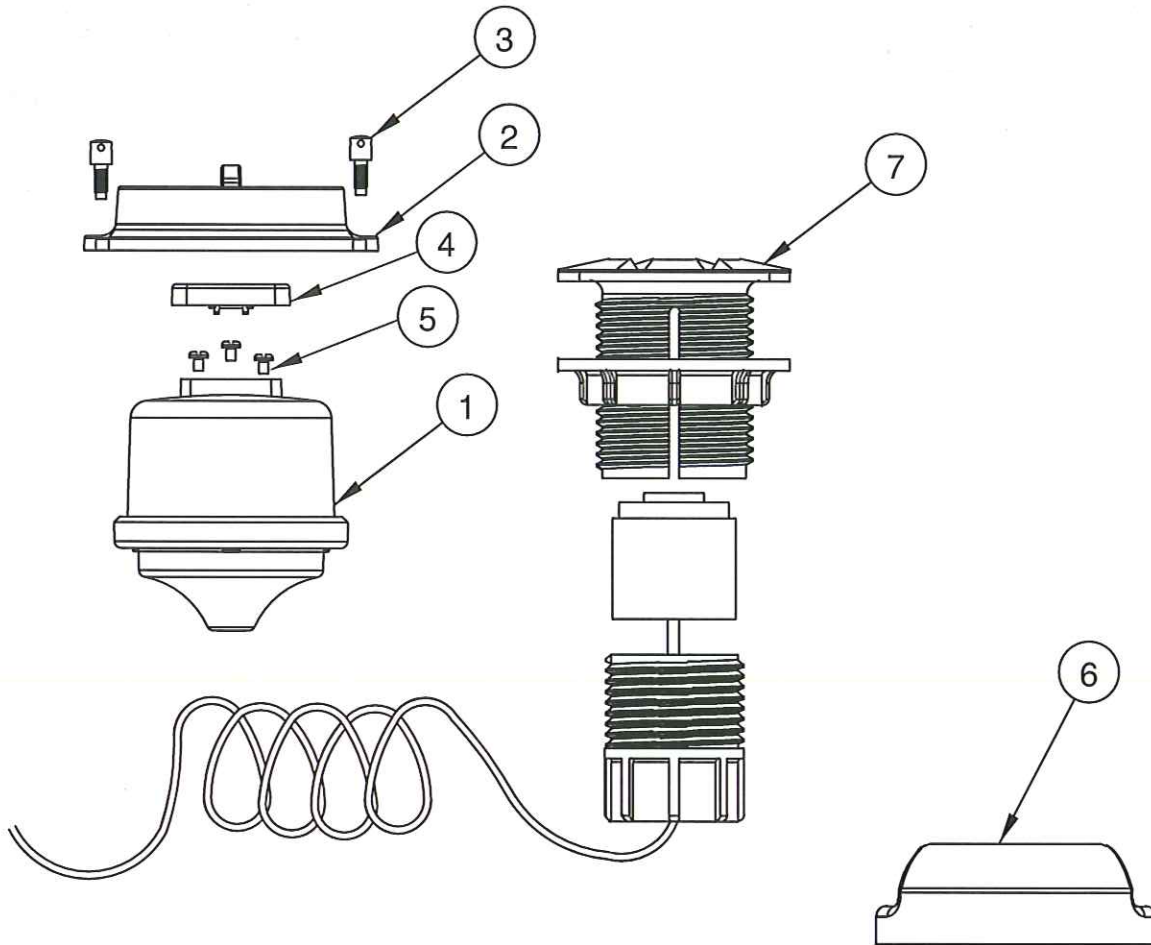

Ref	Description	MVR-350	MVR-650	MVR-1300
1	Translator Register Gallons* Cubic Feet*	D35271xxx D35272xxx	D35281xxx D35282xxx	D35291xxx D35292xxx
2	Register Box (Bronze) Translator Only	C6525	C6525	C6525
3	Register Box Screw	51005P007 (2)	51005P007 (2)	51005P007 (2)
4	Lens Terminal Cover	B8447	B8447	B8447
5	Terminal Lug Screw	98197 (3)	98197 (3)	98197 (3)
6	Wall Pad	T1234	T1234	T1234
7	Pit Pad	T1240	T1240	T1240
8	TrueRead (not shown)	C6551G	C6551G	C6551G
9	1,000' Spool of Wire (not shown)	AS755	AS755	AS755

\*Call Mueller Systems Customer Service for appropriate Translator Register and AMR device part number.